

TMS 1000 NC, TMS 1200 NC MICROCOMPUTERS

DESCRIPTION

The TMS1000 series is a family of P-channel MOS four-bit microcomputers with a ROM, a RAM, and an arithmetic logic unit on a single semiconductor chip. The TMS1000 family is unique in the field of microprocessors because this device is a single-chip binary computer. A customer's specification determines the software that is reproduced during wafer processing by a single-level mask technique that defines a fixed ROM pattern. This versatile one-chip computer is very cost effective and capable of performing a variety of complex functions.

Key features of the TMS1000 series are:

- 8192-bit Read-Only Memory (ROM) on chip
- 256-bit Random-Access Memory (RAM) on chip
- 11 latched control/data-strobe outputs in a 28-pin package
- 13 latched control/data-strobe outputs in a 40-pin package
- 8 parallel data outputs and output programmable logic array (PLA)
- Arithmetic Logic Unit (ALU) and 2 four-bit working registers on chip
- On-chip oscillator, or external synchronization if desired
- Conditional branching and subroutines
- Four-bit parallel data input
- Programmable instruction decoder
- Single-power-supply operation
- TTL compatible

TMS1000 SERIES	
DEVICE	PACKAGE
TMS1000NC	28-Pin DIP
TMS1200NC	40-Pin DIP

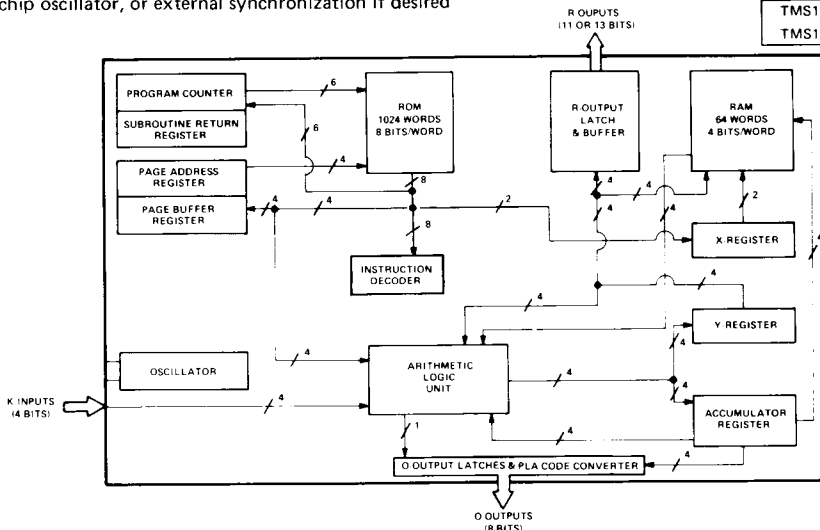

TMS1000-SERIES LOGIC BLOCKS

One major advantage of the TMS1000 series is flexibility. The TMS1000 series is effective in applications such as printer controllers, data terminals, remote sensing systems, cash registers, appliance controls, and automotive applications. Through the TMS1000 series versatility, a wide range of systems realize reduced costs, fewer parts, and high reliability.

The microcomputer's ROM program controls data input, storage, processing, and output. Data processing takes place in the arithmetic logic unit. K input data goes into the ALU, as shown in the figure above, and is stored in the four-bit accumulator. The accumulator output accesses the output latches, the RAM storage cells, and the adder input. Data storage in the 256-bit RAM is organized into 64 words, four bits per word. The four-bit words are conveniently grouped into four 16-word files addressed by a two-bit register. A four-bit register addresses one of the 16 words in a file by ROM control.

The O outputs and the R outputs are the output channels. The eight parallel O outputs are decoded from five data latches. The O outputs serve many applications because the decoder is a programmable logic array (PLA) that is modified by changing the gate-level mask tooling. Each of the thirteen R outputs of the TMS1200NC and the eleven R

TMS 1000 NC, TMS 1200 NC MICROCOMPUTERS

outputs on the TMS1000NC has an individual storage element that can be set or reset by program control. The R outputs send status or enable signals to external devices. The R outputs strobe the O outputs to displays, to other TMS1000 series chips, or to TTL and other interface circuits. The same R outputs multiplex data into the K inputs whenever necessary.

There are 43 basic instructions that handle I/O, constant data from the ROM, bit control, internal data transfer, arithmetic processing, branching, looping, and subroutines. The eight-bit instruction word performs 256 unique operations for maximum efficiency.

DESIGN SUPPORT

Through a staff of experienced application programmers, Texas Instruments will, upon request, assist customers in evaluating applications, in training designers to program the TMS1000 series and in simulating programs. TI will also contract to write programs to customer's specifications.

TI has developed an assembler and simulator for aiding software designs. These programs are available on nationwide time-sharing systems and at TI computer facilities.

A TMS1000 series program (see flowchart) is written in assembly language using standard mnemonics. The assembler converts the source code (assembly language program) into machine code, which is transferred to a software simulation program. Also the assembler produces a machine code object deck. The object deck is used to produce a tape for hardware simulation or a tape for generating prototype tooling.

The TMS1000 series programs are checked by software and hardware simulation. The software simulation offers the advantages of printed outputs for instruction traces or periodic outputs. The hardware simulation offers the designer the advantages of real-time simulation and testing asynchronous inputs. A software user's guide is available.

After the algorithms have been checked and approved by the customer, the final object code and machine option statements are supplied to TI. A gate mask is generated and slices produced. After assembly and testing, the prototypes are shipped to the customer for approval. Upon receiving final approval, the part is released for volume production at the required rate as one unique version of the TMS1000 family.

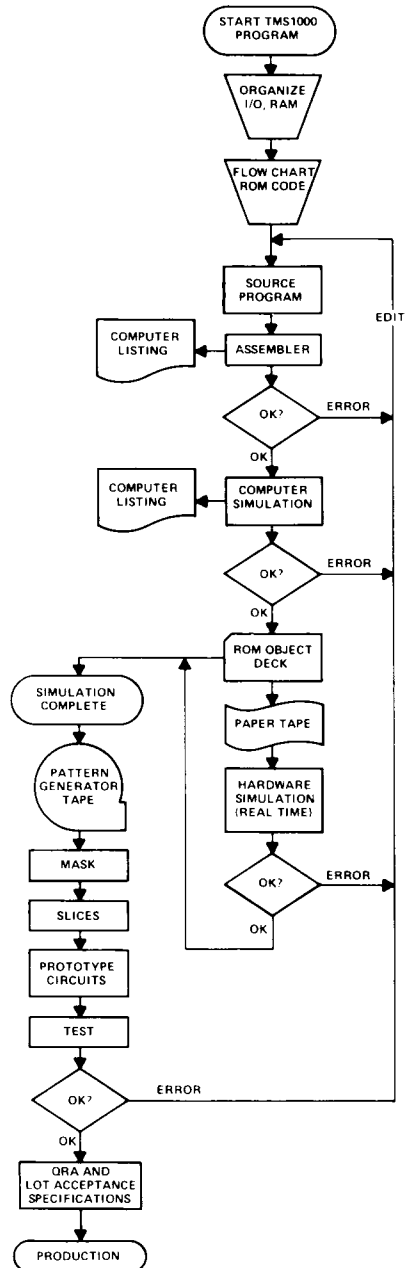

TMS1000-SERIES ALGORITHM DEVELOPMENT