

Shanghai CATIC OPTOELECTRONICS Co. Ltd

TFT COLOR LCD MODULE

(COMMON)

TMS156WX1-01TB

39.5cm (15.6 Type)

WXGA

LVDS Interface (1port)

(Version 1.0)

Published by

Product Technology Department

Shanghai CATIC OPTOELECTRONICS Co. Ltd

Approved by

Date

Johnny Young
Checked by

2009.12.22
Date

Amber Medu
Prepared by

2009.12.22
Date

Chen Hanyuan

2009.12.22

Signature of customer

Confirmed by

Date

INTRODUCTION

• WARRANTY

Shanghai CATIC OPTOELECTRONICS Co. Ltd (hereinafter called "SCO") warrants that this product meets the product specifications set forth in this document. If this product under normal operation is found to be non-conforming to the product specifications, and such non-conformance is promptly notified to SCO within one (1) year after the delivery date, and further such non-conformance is solely attributable to SCO, SCO shall repair the non-conforming product or replace it with a conforming one, free of charge. However, this warranty does not apply to any non-conformance that can be found easily by incoming inspections or those resulting from any one of the following:

- 1) Unauthorized or improper repair, maintenance or modification
- 2) Operation or use against specifications, instructions or warnings given by SCO
- 3) Any other causes attributable to customer

In case SCO repairs or replaces a product after the one (1)-year warranty period, SCO shall be entitled to charge for such repair or replacement. Those replaced parts shall be covered with six (6)-month warranty period from the replacement day. Non-conforming products may be replaced with substitutes instead of repair when the manufacture of this product has been terminated.

EXCEPT AS EXPRESSLY SET FORTH HEREIN, SCO DISCLAIMS ANY WARRANTIES, EXPRESS OR IMPLIED, INCLUDING BUT NOT LIMITED TO MERCHANTABILITY AND FITNESS FOR A PARTICULAR PURPOSE, AND DISCLAIMS ANY REMEDIES.

• MAINTENANCE

The specifications of maintenance parts may be partially changed within equivalent quality or better. In this product, SCO will not accept to maintain for only mounting parts on circuit board (e.g. connector, fuse, capacitor, resistor, etc.) and only backlight conformation parts (e.g. reflector sheet, light guide plate, etc.).

If SCO is planning discontinuation for this product, SCO shall inform it to customers in six (6)-months advance from the issued date of official agreements. In addition, after product discontinuation, SCO may replace substitutes instead of maintenance parts with whole product.

• CHANGE CONTROL

For the purpose of product improvement, this product design may be changed for specifications, appearance, parts, circuits and so on. In case a design change is affected on the product specifications, SCO shall inform it to customers in advance.

• HANDLING OF DOUBTFUL POINTS

Any question arising out of, or in connection with, this SPECIFICATION or any matter not stipulated herein will be settled each time upon consultation between both parties.

CONTENTS

INTRODUCTION.....	2
CONTENTS.....	3
RECORD OF REVISION.....	4
1. OUTLINE	5
1.1 STRUCTURE AND PRINCIPLE	5
1.2 APPLICATIONS	5
1.3 FEATURES	5
2. GENERAL SPECIFICATIONS	6
3. ABSOLUTE MAXIMUM RATINGS.....	7
4. BLOCK DIAGRAM.....	8
5. MECHANICAL SPECIFICATIONS	9
6. ELECTRICAL CHARACTERISTICS	9
6.1 DRIVING FOR LCD.....	9
6.2 DRIVING FOR BACKLIGHT.....	10
7. CONNECTIONS AND FUNCTIONS FOR INTERFACE PINS.....	11
7.1 LCD PANEL SIGNAL PROCESSING PINS.....	11
7.2 BACKLIGHT LAMP.....	12
7.3 POSITION OF PLUGS AND A SOCKET.....	12
7.4 CONNECTION BETWEEN REVIEVER AND TRANSMITTER FOR LVDS.....	13
8. DISPLAY COLORS AND INPUT DATA SIGNALS.....	14
9.INTERFACE TIMING.....	15
9.1 TIMING CHARACTERISTICS.....	15
9.2 INPUT SIGNAL TIMING CHART.....	16
9.3 PIXEL DATA ALIGNMNET OF DISPLAY IMAGE.....	16
9.4 POWER SUPPLY VOLTAGE SEQUENCE	17
10. OPTICS.....	19
11. MARKINGS.....	21
11.1 PRODUCT LABEL.....	21
11.2 BARCODE LABEL	21
11.3 OTHER MARKINGS	21
11.4 INDICATION LOCATIONS.....	22
12. PACKING, TRANSPORTATION AND DELIVERY	23
13. PRECAUTIONS	25
13.1 MEANING OF CUTION SIGNS	25
13.2 CAUTIONS.....	25
13.3 ATTENTIONS.....	25
14.OUTDRAWING.....	27

1. OUTLINE

1.1 STRUCTURE AND PRINCIPLE

TMS156WX1-01TB module is composed of the amorphous silicon thin film transistor liquid crystal display (a-Si TFT LCD) panel structure with driver LSIs for driving the TFT (Thin Film Transistor) array and a backlight. The a-Si TFT LCD panel structure is injected liquid crystal material into a narrow gap between the TFT array glass substrate and a color-filter glass substrate.

Color (Red, Green, Blue) data signals from a host system (e.g. PC, signal generator, etc.) are modulated into best form for active matrix system by a signal processing board, and sent to the driver LSIs which drive the individual TFT arrays. The TFT array as an electro-optical switch regulates the amount of transmitted light from the backlight assembly, when it is controlled by data signals. Color images are created by regulating the amount of transmitted light through the TFT array of red, green and blue dots.

1.2 APPLICATIONS

- Small Monitor / TV application

1.3 FEATURES

- a-Si TFT active matrix
- LVDS interface
- R.G.B input 8bit, 16.77 millions colors (6bit+Hi-FRC)
- Resolution: (1,366×768 pixels)
- High contrast ratio: 500:1
- Module size: 363.8(H) ×215.9(V) ×14.3(D)mm
- High response time (Ton+Toff=8 ms)
- High gamut: (against NTSC 60%typ.)
- Edge light type backlight (2 CCFL lamps)
- Inverter less
- RoHS compliance
- TCO'03 compliance

2. GENERAL SPECIFICATIONS

<i>Display area</i>	344.232 (W) x 193.536 (H) mm (typ.)
<i>Diagonal size of display</i>	39.5cm (15.6 inches)
<i>Drive system</i>	a-Si TFT active matrix
<i>Display color</i>	16,777,216 colors (6bit+FRC)
<i>Pixel</i>	1,366 (H) x 768 (V) pixels
<i>Pixel arrangement</i>	RGB vertical stripe
<i>Dot pitch</i>	0.084(W) x 0.252 (H) mm
<i>Pixel pitch</i>	0.252 (W) x 0.252 (H) mm
<i>Module size</i>	363.8±0.5(W) x 215.9±0.5(H) x 14.3 (D) mm (typ.)
<i>Weight</i>	1300g (max.)
<i>Contrast ratio</i>	500:1 (typ.)
<i>Viewing angle</i>	90°/ 70° (typ.)
<i>Color gamut</i>	60 % (typ.)
<i>Response time</i>	8 ms (typ.)
<i>Luminance</i>	250cd/m ² (typ.)
<i>Transmissive Mode</i>	Normally White
<i>Surface Treatment</i>	AG Type
<i>Signal system</i>	LVDS 1port
<i>Power supply voltage</i>	LCD panel signal processing board: 5.0V
<i>Backlight</i>	2 cold cathode fluorescent lamps
<i>Power consumption</i>	(12)W (typ.)

3. ABSOLUTE MAXIMUM RATINGS

Parameter		Symbol	Rating	Unit	Remarks
Power supply voltage	LCD panel signal board	VDD	-0.3 ~ +6.0	V	Ta = 25°C
Input voltage for signals	Display signals Note1	Vi	-0.3 ~ +3.2	V	Ta = 25°C
Storage temperature		Tst	-20 ~ +60	°C	Note3
Operating temperature		Top	0 ~ +55	°C	Note3, 4
Absolute humidity		AH	≤ 70	g/m ³	Ta > 55°C
Operating altitude		-	≤ 4, 850	m	0° C ≤ Ta ≤ 55° C
Storage altitude		-	≤ 13, 600	m	-20° C ≤ Ta ≤ 60° C

Note1: Display signals are D0+/-, D1+/-, D2+/-, D3+/- and CK+/-.

Note2: Function signal is MSL.

Note3: Temperature and relative humidity range is shown in the figure below.

(a) 90%RH Max. (Ta ≤ 40°C)

(b) Web-bulb temperature should be 39°C Max. (Ta > 40°C)

(c) No condensation.

Note4: The temperature of panel display surface area should be 0°C Min and 60°C Max.

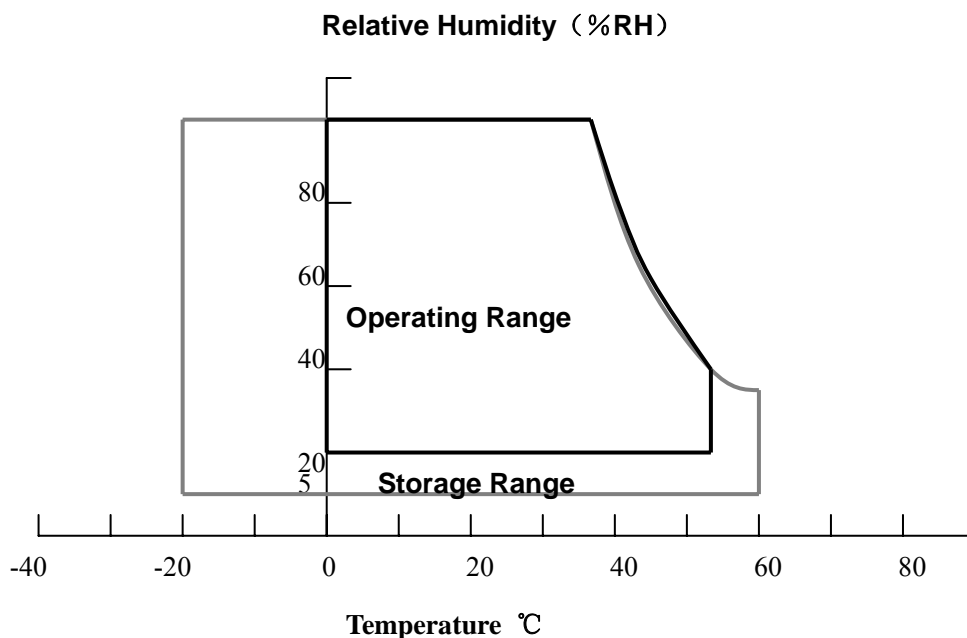

4. BLOCK DIAGRAM

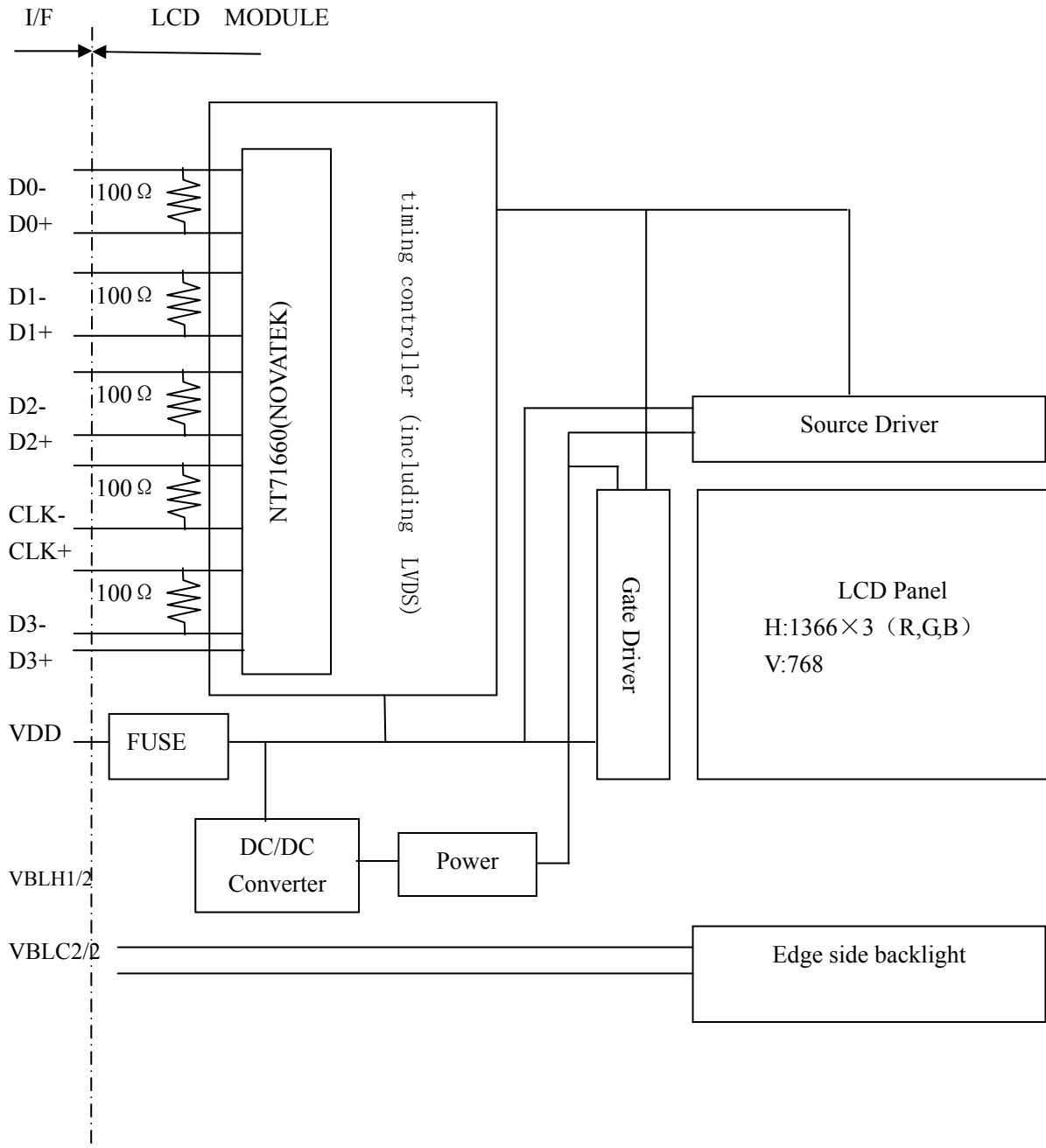

Note1: Connections between GND, FG (Frame ground) and VBLC (Lamp low voltage terminal) in the product

GND - FG	Connected
GND - VBLC	Not connected
FG - VBLC	Not connected

Note2: These grounds should be connected together in customer equipment.

5. MECHANICAL SPECIFICATIONS

Parameter	Specification	Unit
Module size	363.8±0.5 (W) ×215.9±0.5 (H) ×14.3 (D)	mm
Display area	344.232 (W) x 193.536 (H) (typ.)	mm
Weight	1300 (typ.)	g

6. ELECTRICAL CHARACTERISTICS

6.1 Driving for LCD panel signal processing board

Parameter	Symbol	min.	typ.	max.	Unit	Remarks
Power supply voltage	VDD	4.5	5.0	5.5	V	-
Power supply current	IDD	-	400Note1	600Note 2	mA	at VDD =5.0V
Permissible ripple voltage	VRP	-	-	100	mV	VDD
Differential input threshold voltage for LVDS receiver	Low	VTL	-	-100	mV	atVCM = 1.25V Note3
	High	VTH	-	-	100	
Input voltage width for LVDS receiver	Vi	0	-	2.5	V	-
Terminating resistor	RT	-	100	-	Ω	-
Rush current	I _{rush}	-	-	2.0	A	Note4

Note 1: Checkered flag pattern (EIAJ ED-2522);

Note 2: 2H1V dot inverse pattern

Note 3: Common mode voltage for LVDS receiver

Note4: Measurement Conditions:

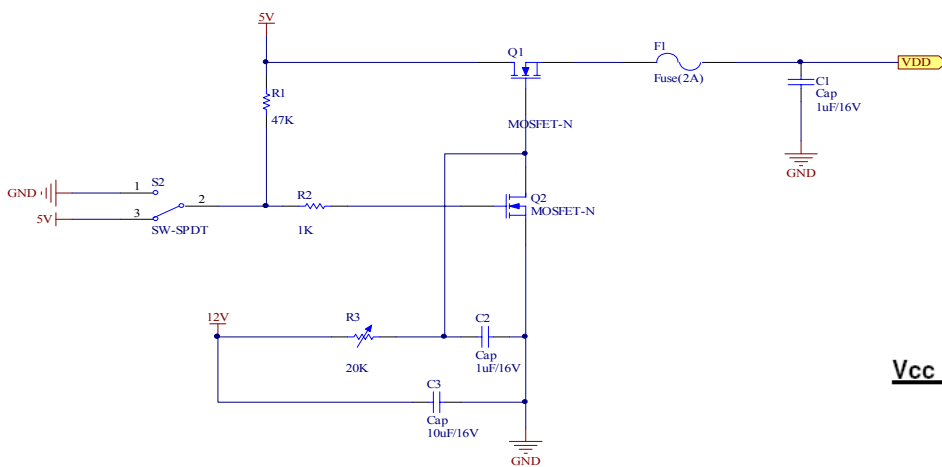

Vcc rising time is 470μs

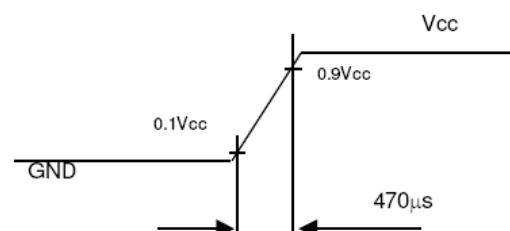

6.2 Driving for backlight lamp

Parameter	Symbol	min.	typ.	max.	Unit	Remarks
Lamp voltage	VBLH	585	650	715	Vrms	For each lamp
Lamp current	IBL	3.0	7.0	8.0	mArms	Note3
Lamp starting voltage	VS	-	-	1490	Vrms	Ta = 25°C Note2
Note1		-	-	1520	Vrms	Ta = 0°C Note2
Oscillation frequency	FO	50	55	60	kHz	Note3

Note1: The value is the characteristic of lamp. The starting voltage of inverter should be lower than the value. But the possibility of not lighting exists by the lower voltage, so the suitable voltage should be considered by the test.

Note2: The asymmetric ratio of working waveform for lamps (Lamp voltage peak ratio, Lamp current peak ratio and waveform space ratio) should be less than 5% (See the following figure). If the waveform is asymmetric, DC (Direct current) element applies into the lamp. In this case, a lamp lifetime may be shortened, because a distribution of a lamp enclosure substance inclines toward one side between low voltage terminal (Cold terminal) and high voltage terminal (Hot terminal).

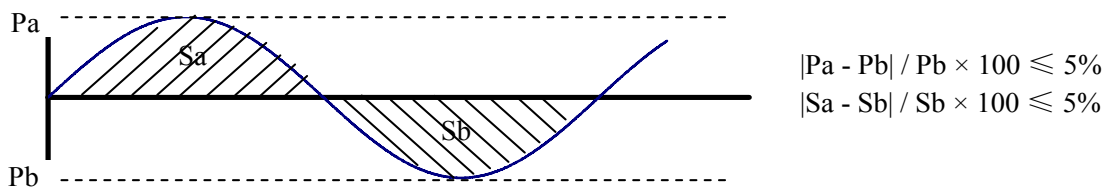

Pa: Supply voltage/current peak for positive, Pb: Supply voltage/current peak for negative

Sa: Waveform space for positive part, Sb: Waveform space for negative part

Note3: Recommended value of "FO" is as following.

$$FO = 1/4 \times 1/th \times (2n-1) \quad n: \text{Natural number } (1, 2, 3 \dots\dots)$$

7. CONNECTIONS AND FUNCTIONS FOR INTERFACE PINS

7.1 LCD panel signal processing board

CN1:FI-X30SSL-HF or equivalent

Pin No.	Symbol	Description
1	NC	Not connection
2	NC	Not connection
3	NC	Not connection
4	GND	Ground
5	RX0-	Negative LVDS differential data input. Channel 0
6	RX0+	Positive LVDS differential data input. Channel 0
7	GND	Ground
8	RX1-	Negative LVDS differential data input. Channel 1
9	RX1+	Positive LVDS differential data input. Channel 1
10	GND	Ground
11	RX2-	Negative LVDS differential data input. Channel 2
12	RX2+	Positive LVDS differential data input. Channel 2
13	GND	Ground
14	RXCLK-	Negative LVDS differential clock input.
15	RXCLK+	Positive LVDS differential clock input.
16	GND	Ground
17	RX3-	Negative LVDS differential data input. Channel 3
18	RX3+	Positive LVDS differential data input. Channel 3
19	GND	Ground
20	NC	Not connection
21	NC	Not connection
22	NC	Not connection
23	GND	Ground
24	GND	Ground
25	GND	Ground
26	VCC	+5.0V power supply
27	VCC	+5.0V power supply
28	VCC	+5.0V power supply
29	VCC	+5.0V power supply
30	VCC	+5.0V power supply

7.2 Backlight lamp

CN201 CN202 plug (LCD module side): :(Yeonho)3500011HS-02L/Locking Type or Equivalent

Pin No.	Symbol	signal	remarks
1	VBLH	High voltage terminal(Hot)	Cable color: Pink
2	VBLC	Low voltage terminal(Cold)	Cable color: White

7.3 Position of plugs and a socket

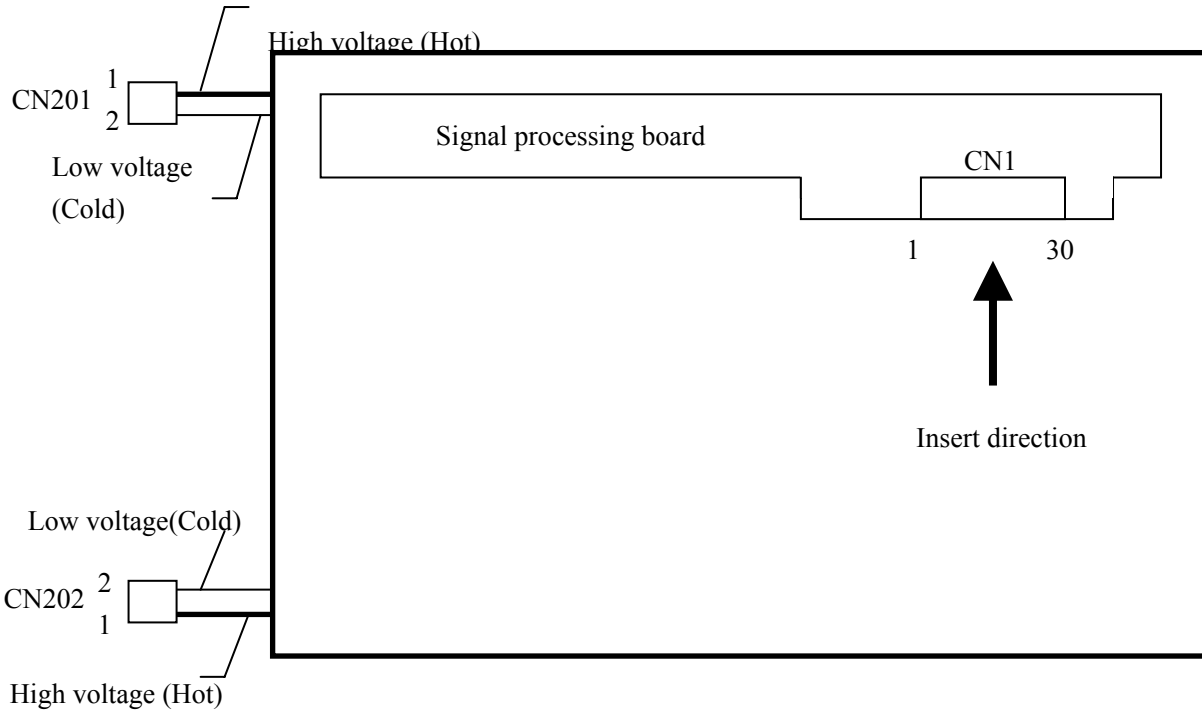

7.4 Connection between receiver and transmitter for LVDS

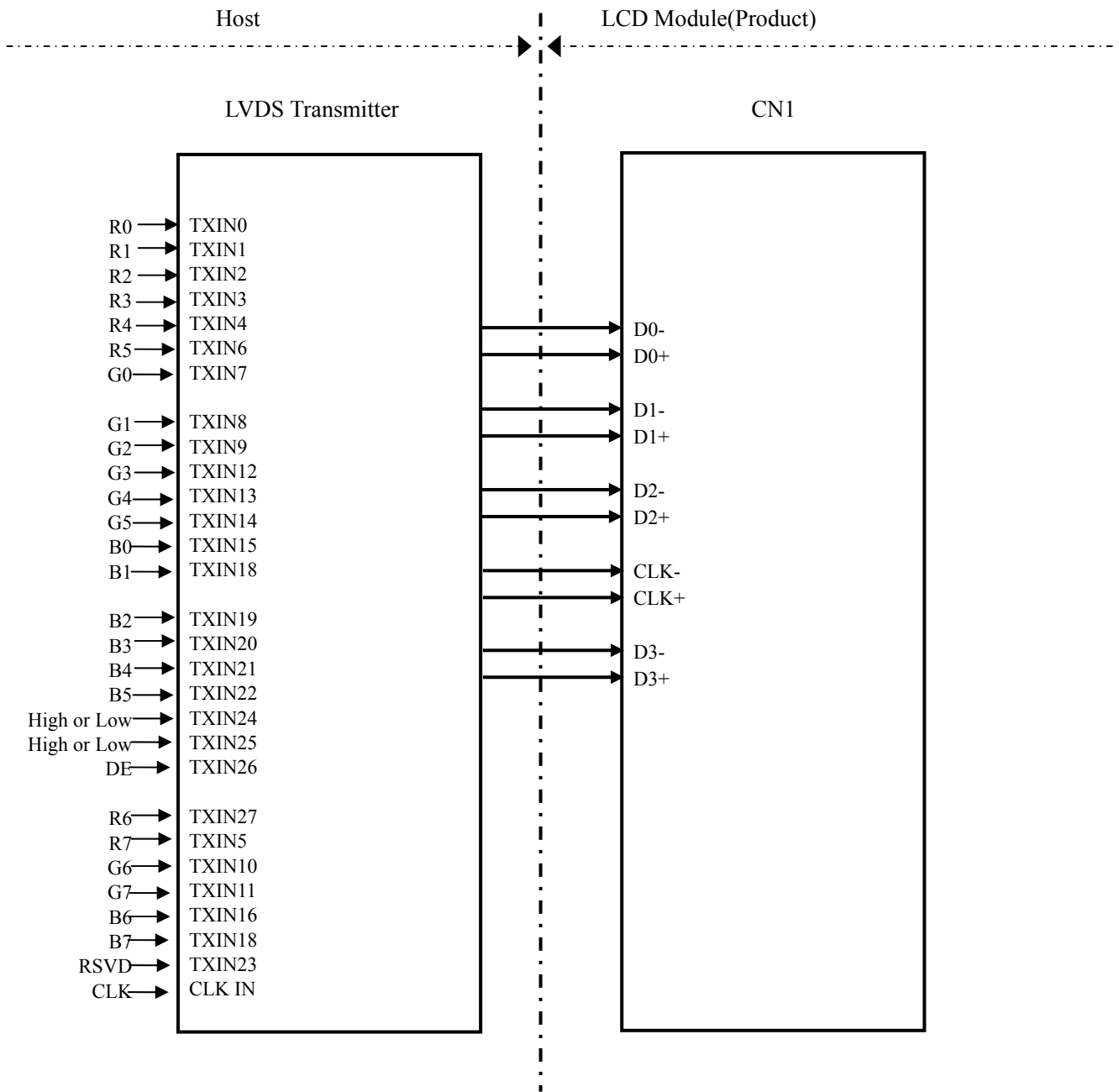

8. DISPLAY COLORS AND INPUT DATA SIGNALS

This product can display in equivalent to 16,777,216 colors in 256 scale. Also the relation between display colors and input data signals is as the following table.

Display colors		Data signal (0:Low level, 1:High Level)																								
		R7	R6	R5	R4	R3	R2	R1	R0	G7	G6	G5	G4	G3	G2	G1	G0	B7	B6	B5	B4	B3	B2	B1	B0	
Basic Color	Black	0	0	0	0	0	0	0	0	0	0	0	0	0	0	0	0	0	0	0	0	0	0	0	0	
	Blue	0	0	0	0	0	0	0	0	0	0	0	0	0	0	0	0	1	1	1	1	1	1	1	1	
	Red	1	1	1	1	1	1	1	1	0	0	0	0	0	0	0	0	0	0	0	0	0	0	0	0	
	Magenta	1	1	1	1	1	1	1	1	0	0	0	0	0	0	0	0	1	1	1	1	1	1	1	1	
	Green	0	0	0	0	0	0	0	0	1	1	1	1	1	1	1	1	0	0	0	0	0	0	0	0	
	Cyan	0	0	0	0	0	0	0	0	1	1	1	1	1	1	1	1	1	1	1	1	1	1	1	1	
	Yellow	1	1	1	1	1	1	1	1	1	1	1	1	1	1	1	1	0	0	0	0	0	0	0	0	
	White	1	1	1	1	1	1	1	1	1	1	1	1	1	1	1	1	1	1	1	1	1	1	1	1	
Red grayscale	Black	0	0	0	0	0	0	0	0	0	0	0	0	0	0	0	0	0	0	0	0	0	0	0	0	
		0	0	0	0	0	0	0	1	0	0	0	0	0	0	0	0	0	0	0	0	0	0	0	0	
	Dark	0	0	0	0	0	0	1	0	0	0	0	0	0	0	0	0	0	0	0	0	0	0	0	0	
	↑				:																					
	↓				:																					
	Bright	1	1	1	1	1	1	0	1	0	0	0	0	0	0	0	0	0	0	0	0	0	0	0	0	
Red	1	1	1	1	1	1	1	0	0	0	0	0	0	0	0	0	0	0	0	0	0	0	0	0		
	1	1	1	1	1	1	1	1	0	0	0	0	0	0	0	0	0	0	0	0	0	0	0	0		
Green grayscale	Black	0	0	0	0	0	0	0	0	0	0	0	0	0	0	0	0	0	0	0	0	0	0	0	0	
		0	0	0	0	0	0	0	0	0	0	0	0	0	0	0	1	0	0	0	0	0	0	0	0	
	Dark	0	0	0	0	0	0	0	0	0	0	0	0	0	0	1	0	0	0	0	0	0	0	0	0	
	↑				:																					
	↓				:																					
	Bright	0	0	0	0	0	0	0	0	1	1	1	1	1	1	0	1	0	0	0	0	0	0	0	0	
Green	0	0	0	0	0	0	0	0	1	1	1	1	1	1	1	0	0	0	0	0	0	0	0	0		
	0	0	0	0	0	0	0	0	1	1	1	1	1	1	1	1	0	0	0	0	0	0	0	0		
Blue grayscale	Black	0	0	0	0	0	0	0	0	0	0	0	0	0	0	0	0	0	0	0	0	0	0	0	0	
		0	0	0	0	0	0	0	0	0	0	0	0	0	0	0	0	0	0	0	0	0	0	0	1	
	Dark	0	0	0	0	0	0	0	0	0	0	0	0	0	0	0	0	0	0	0	0	0	0	1	0	
	↑				:																					
	↓				:																					
	Bright	0	0	0	0	0	0	0	0	0	0	0	0	0	0	0	0	1	1	1	1	1	1	0	1	
Blue	0	0	0	0	0	0	0	0	0	0	0	0	0	0	0	0	1	1	1	1	1	1	1	0		
	0	0	0	0	0	0	0	0	0	0	0	0	0	0	0	0	1	1	1	1	1	1	1	1		

9. INTERFACE TIMING

9.1 Timing characteristics

(Note1)

Parameter		Symbol	min.	typ.	max.	Unit	Remarks	
CLK	Frequency	1/tc	62	76	94	MHz	15.384ns (typ.)	
	Duty	—	Refer to the timing characteristics of LVDS transmitter			—	Note2	
	Rise time, Fall time	—				ns		
DATA	CLK-DATA	Setup time	—	Refer to the timing characteristics of LVDS transmitter			ns	Note2
		Hold time	—				ns	
	Rise time, Fall time	—				ns		
DE	Horizontal	Cycle	th	-	20.676	-	μs	48.363KHz(typ.)
				1446	1560	1936	CLK	Note3 Note4
	Vertical (One frame)	Cycle	tv	13.33	16.67	25.00	ms	60.0Hz (typ.)
				778	806	888	H	
	Display period	tvd	768			H	—	
	CLK-DE	Setup time	—	Refer to the timing characteristics of LVDS transmitter			ns	Note2
Hold time		—				ns		
Rise time, Fall time		—				ns		

Note1: Definition of parameters is follows. tc=1CLK,Th=1H

Note 2: See the data sheet of LVDS transmitter.

Note 3: Both of “time” and “CLK number” of the “th” must keep the Minimum value of specifications.

Note 4: “th” must keep the fluctuation within ± 1 CLK, because of avoidance of image sticking.

9.2 Input signal timing chart

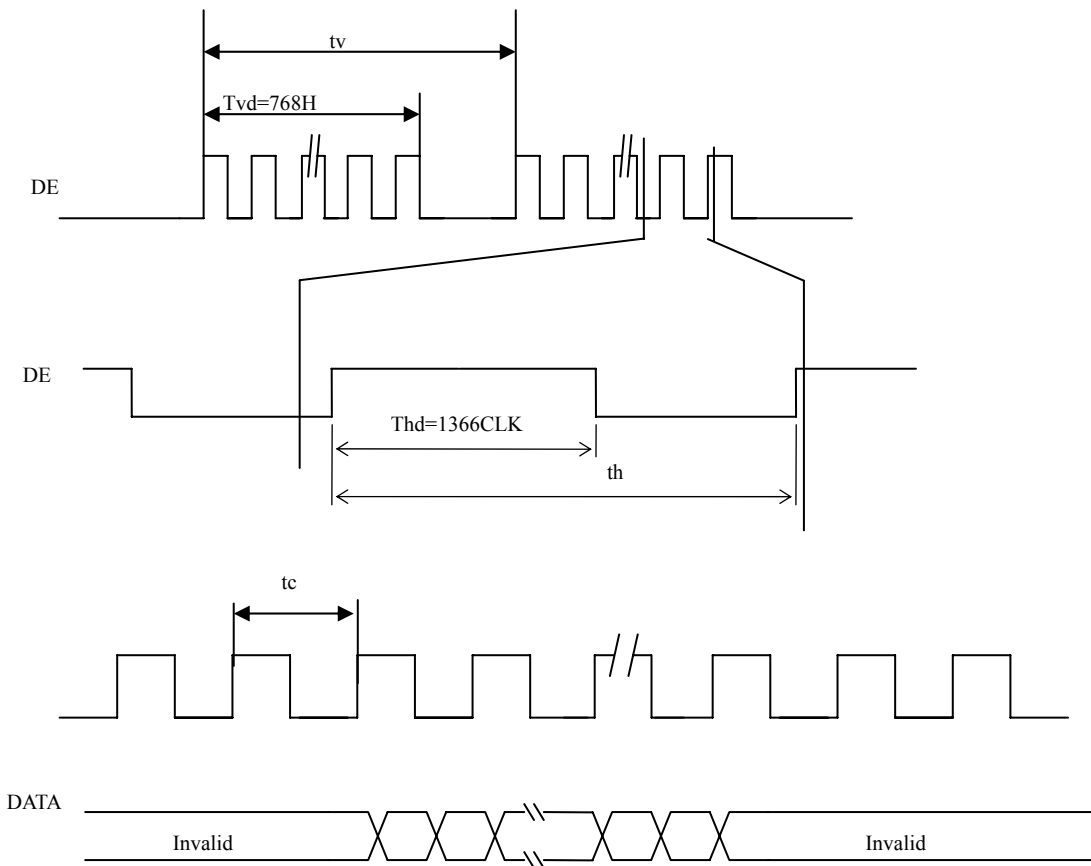

9.3 Pixel DATA alignment of display image

The following table is the coordinates per pixel

C (1, 1)									
<table border="1" style="margin: auto;"> <tr> <td style="padding: 2px;">R</td> <td style="padding: 2px;">G</td> <td style="padding: 2px;">B</td> </tr> </table>							R	G	B
R	G	B							
C (1, 1)	C (2, 1)	...	C (X, 1)	...	C (1365, 1)	C (1366, 1)			
C (1, 2)	C (2, 2)	...	C (X, Y)	...	C (1365, 2)	C (1366, 2)			
•	•	•	•	•	•	•			
•	•	...	•	...	•	•			
•	•	•	•	•	•	•			
C (1, Y)	C (2, Y)	...	C (X, Y)	...	C (1365, Y)	C (1366, Y)			
•	•	•	•	•	•	•			
•	•	...	•	...	•	•			
•	•	•	•	•	•	•			
C (1, 767)	C (2, 767)	...	C (X, 767)	...	C (1365, 767)	C (1366, 767)			
C (1, 768)	C (2, 768)	...	C (X, 768)	...	C (1365, 768)	C (1366, 768)			

9.4. POWER SUPPLY VOLTAGE SEQUENCE

9.4.1 The sequence of backlight and power

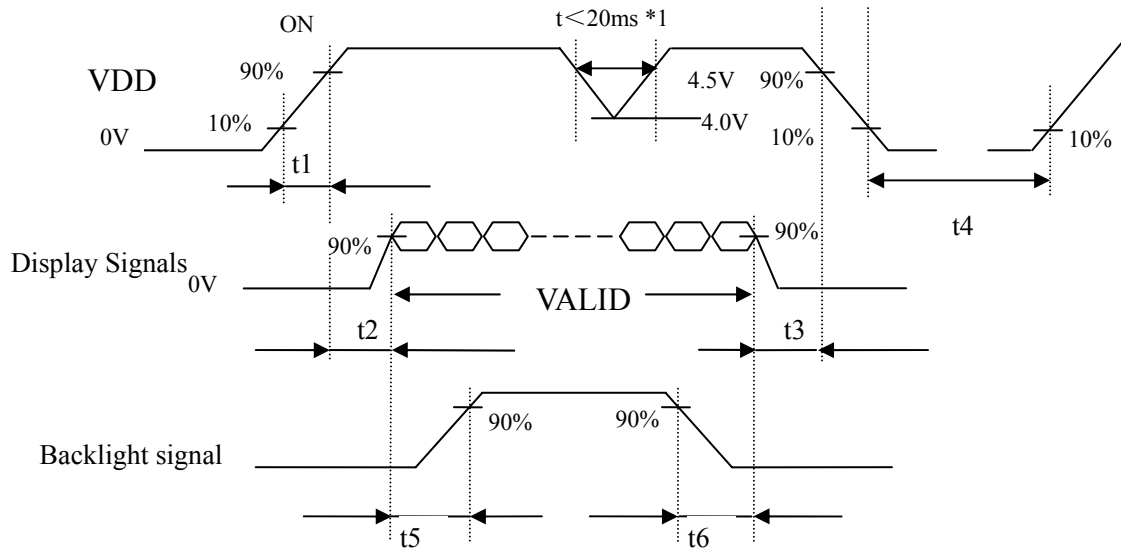

Timing Specifications:

0.5ms < t1 < 10ms; 0 ms < t2 < 50ms; 0ms < t3 < 50ms;
 t4 > 500ms; t5 > 450ms; t6 > 90ms;

*1: These signals should be measured at the terminal of 100Ω resistor.

Note1: In terms of voltage variation (voltage drop) while VCC rising edge is below 4.5 V, a protection circuit may work, and then this product may not work.

Note2: If some of interface signals of this product are cut while this product is working, even if the signal input to it once again, it might not work normally. If customer stops the interface signals, they should cut VCC.

Note3: The backlight power supply voltage should be inputted within the valid period of interface signals, in order to avoid unstable data display.

9.4.2 Power supply voltage ripple

This product works, even if the ripple voltage levels are beyond the permissible values as the following table, but there might be noise on the display image.

Parameter	Power supply voltage	Ripple voltage Note1(Measured at input terminal of power supply)	Unit
VCC	5.0 V	≤ 100	mVp-p

Note1: The permissible ripple voltage includes spike noise.

9.4.3 Fuse

Parameter	Fuse		Rating	Fusing current	Remarks
	Type	Supplier			
VDD	TF16SN2.50	KOA Corporation	1.5 A	5.0 A	Note1
			32 V		

Note1: The power supply capacity should be more than the fusing current. If the power supply capacity is less than the fusing current, the fuse may not blow for a short time, and then nasty smell, smoking and so on may occur.

10. OPTICS

10.1 Optical characteristics

Parameter Note1		Condition	Symbol	min.	typ.	max.	Unit
Luminance		White at center R=0, L=0, U=0,D=0	L	200	250	-	cd/ m ²
Contrast ratio		White/Black at center R=0, L=0, U=0,D=0	CR	350	500	-	-
Luminance uniformity		-	LU	-	1.4	1.5	-
Chromaticity	White	X coordinate	Wx	0.283	0.313	0.343	-
		Y coordinate	Wy	0.299	0.329	0.359	-
	Red	X coordinate	Rx	0.60	0.63	0.66	-
		Y coordinate	Ry	0.31	0.34	0.37	-
	Green	X coordinate	Gx	0.27	0.30	0.33	-
		Y coordinate	Gy	0.54	0.57	0.60	-
	Blue	X coordinate	Bx	0.11	0.14	0.17	-
		Y coordinate	By	0.07	0.10	0.13	-
Color gamut		R=0, L=0, U=0,D=0	C	50	60	-	%
Response time		White to black	Ton	-	2	4	ms
		Black to white	Toff	-	6	12	ms
Viewing angle	Right	$\theta U=0^\circ, \theta D=0^\circ, CR=10$	θR	40	45	-	°
	Left	$\theta U=0^\circ, \theta D=0^\circ, CR=10$	θL	40	45	-	°
	Up	$\theta R=0^\circ, \theta L=0^\circ, CR=10$	θU	15	20	-	°
	Down	$\theta R=0^\circ, \theta L=0^\circ, CR=10$	θD	40	45	-	°

Note1: Measurement conditions are follows.

Ta=25°C, VCC=5.0V, IBL=7.0mA/lamp, FO=55±5KHz, WXGA+, Vertical cycle=60.0Hz.
Optical characteristics are measured at luminance saturation after 30minutes from working the product in the dark room. Also measurement method for luminance is as follows.

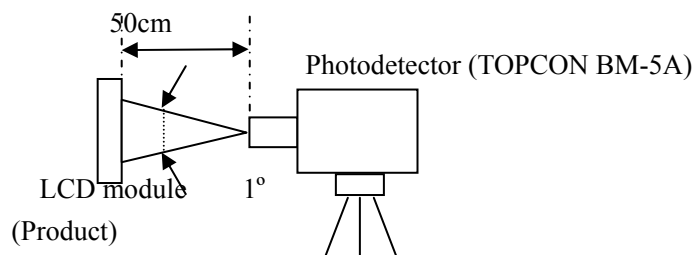

Note 2: See“**10.2 Definition of contrast ratio**”.

Note 3: See“**10.3 Definition of luminance uniformity**”.

Note 4: Temperature: Top=25.0°C

Note 5: See “**10.4 Definition of response times**”.

Note 6: See “**10.5 Definition of viewing angles**”.

10.2 Definition of contrast ratio

The contrast ratio is calculated by using the following formula.

$$\text{Contrast ratio (CR)} = \frac{\text{Luminance of white screen}}{\text{Luminance of black screen}}$$

10.3 Definition of luminance uniformity

The luminance uniformity is calculated by using the following formula.

$$\text{Luminance uniformity (LU)} = \frac{\text{Maximum luminance from ① to ⑨}}{\text{Minimum luminance from ① to ⑨}}$$

The luminance is measured at near the 9 points shown below.

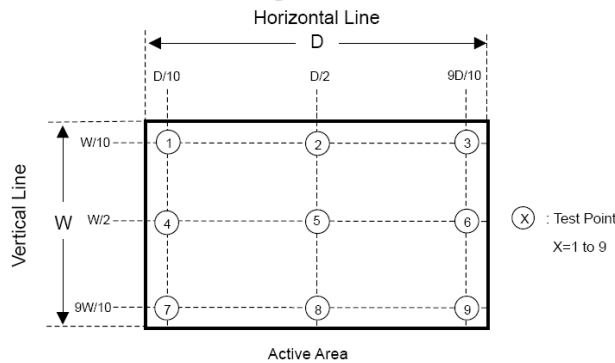

10.4 Definition of response times

Response time is measured, the luminance changes from “white” to “black”, or “black” to “white” on the same screen point, by photo-detector. Ton is the time it takes the luminance change from 90% down to 10%. Also Toff is the time it takes the luminance change from 10% up to 90%. (See the following diagram.)

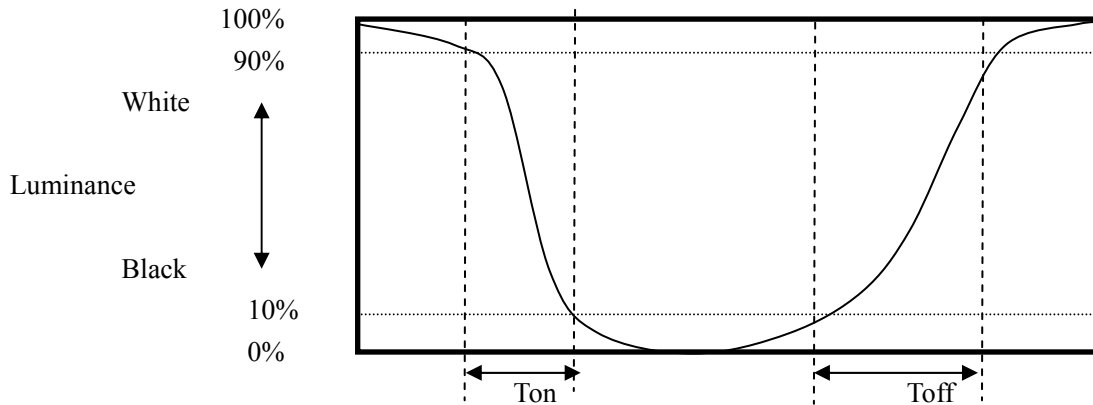

10.5 Definition of viewing angles

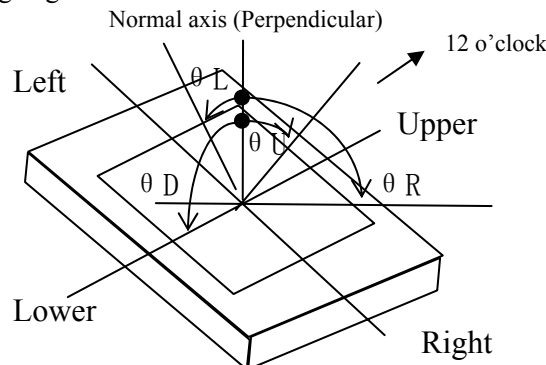

11. MARKINGS

The various markings are attached to this product. See “11.4 INDECATION LOCATIONS” for attachment positions.

11.1 PRODUCT LABEL



Note1: The meaning of lot number

•Example: 1111A104201001

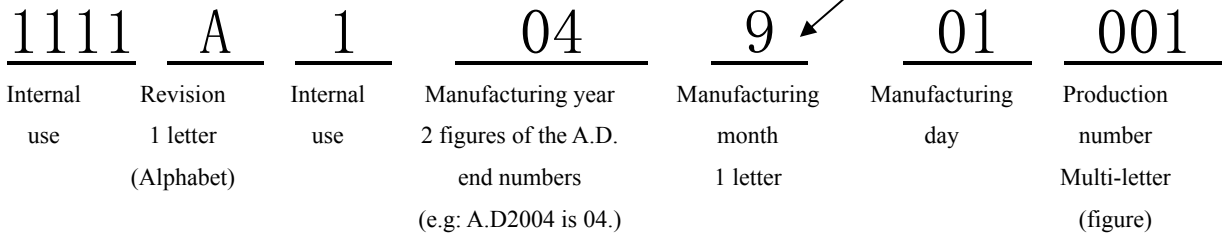

Note2: **Do not attach anything such as label and so on, on the product label!** In case repair the product, SCO needs the contents of product label such as the lot number, inspection date and so on, to identify the warranty period with individual product. If SCO cannot decipher the contents of product label, such repair shall be entitled to charge. Also SCO may give a new lot number to reconditioned products.

11.2 BARCODE LABEL



11.3 OTHER MARKINGS

High voltage caution marking



Disposal method marking for lamp

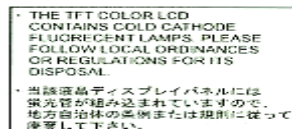

11.4 INDICATION LOCATIONS

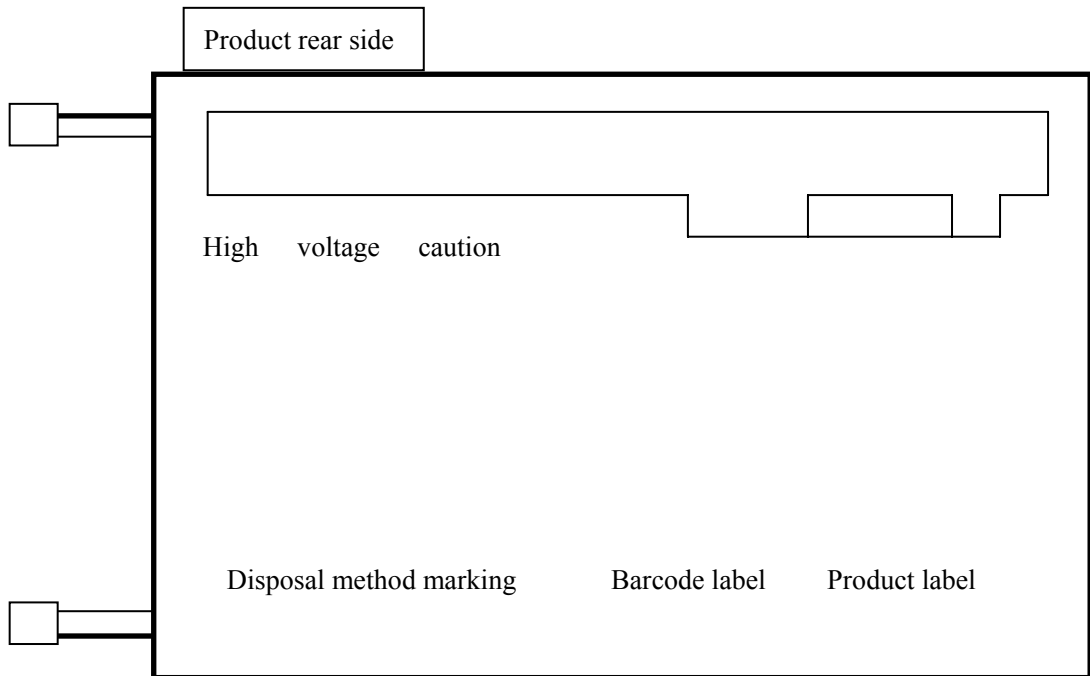

12. PACKING, TRANSPORTATION AND DELIVERY

SCO will pack products to deliver to customer in accordance with SCO packing specifications, and will deliver products to customer in such a state that products will not suffer from a damage during transportation .The delivery conditions are as follows.

12.1 PACKING

(1) Packing box

8 products are packed up with the maximum in a packing box(See “**12.5 OUTLINE FIGURE FOR PACKING** “). Products are put into a plastic bag for prevention of moisture with cushion, and then the bag is sealed up with heat sealing.

The type name and quality are shown on outside of the packing box, either labeling or printing.

(2)Pallet Packing (See”**12.5 OUTLINE FIGURE FOR PACKING** “)

- ① Packing boxes are tired on a cardboard pallet.(9 boxes×4 tiers maximum)
- ②Cardboard sleeve and top cap are attached to the packing boxes, then they are fixed by a band.

12.2 INSPECTION RECORD SHEET

Inspection record sheets are included in the packing box with delivery products to customer. It is summarized to a number of products for pass/fail assessment.

12.3 TRANSPORTATION

The product is transported by vehicle, aircraft or shipment in the state of pallet packing.

12.4 SIZE AND WEIGHT FOR PACKING BOX

Parameter	Packing box	Unit
Size	237 (L) x317 (W) x446 (H) (typ.)	mm
Weight	1.3 (max.)	kg
Total weight	11 (for reference) (with 8 products)	kg

12.5 OUTLINE FIGURE FOR PACKING

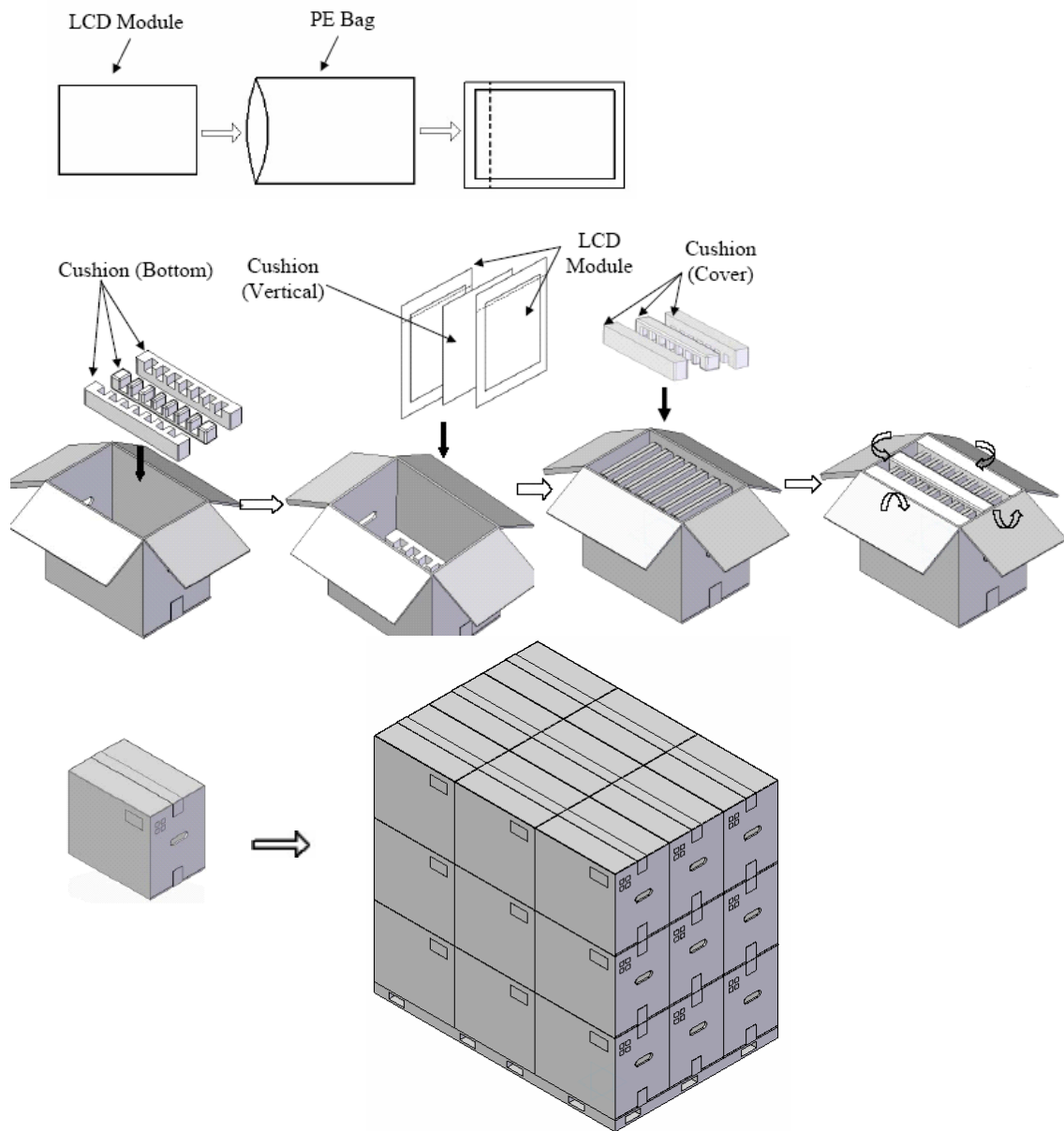

13. PRECAUTIONS

13.1 MEANING OF CAUTION SIGNS

The following caution signs have very important meaning. **Be sure to read “9.2 CAUTIONS” and “9.3 ATTENTIONS”, after understanding these contents!**



This sign has the meaning that customer will be injured by himself or the product will sustain a damage, if customer has wrong operations.



This sign has the meaning that customer will get an electrical shock, if customer has wrong operations.



This sign has the meaning that customer will be injured by himself, if customer has wrong operations.

13.2 CAUTIONS



Do not touch lamp cables while turn on. Customers will be in danger of an electric shock



- * Do not touch the working backlight and IC. Customers will be in danger of burn injury.**
- * Do not shock and press the LCD panel and the backlight! There is a danger of breaking, because they are made of glass.(shock :To be not greater 294m/s^2 and to be not greater 11ms, Pressure: To be not greater 19.6N)**

13.3 ATTENTIONS



13.1 Handling of the product

- ① Take hold of both ends without touch the circuit board when customer pulls out products (LCD modules) from inner packing box. If customer touches it, products may be broken down or out of adjustment, because of stress to mounting parts.
- ② Do not hook cables nor pull connection cables such as flexible cable and so on, for fear of damage.
- ③ If customer puts down the product temporarily, the product puts on flat subsoil as a display side turns down.
- ④ Take the measures of electrostatic discharge such as earth band, ionic shower and so on, when customer deal with the product, because products may be damaged by electrostatic.
- ⑤ The torque for mounting screws must never exceed 0.34N-m. Higher torque values might result in distortion of the bezel.
- ⑥ The product must be installed using mounting holes without undue stress such as bends or twist (See outline drawings). And do not add undue stress to any portion (such as bezel flat area) except mounting hole portion. Bends or twist described above and undue stress to any portion except mounting hole portion may cause display

un-uniformity.

- ⑦ Do not press or rub on the sensitive display surface .If customer clean on the panel surface, SCO recommends using the cloth with ethanolic liquid such as screen cleaner for LCD.
- ⑧ Do not push-pull the interface connectors while the product is working, because wrong power sequence may break down the product.
- ⑨ Do not bend or unbend the lamp cable at the near part of the lamp holding rubber, to avoid the damage for high voltage side of the lamp. This damage may cause a lamp breaking and abnormal operation of high voltage circuit.

13.2 Environment

- ① Do not operate or store in high temperature, high humidity, dewdrop atmosphere or corrosive gases. Keep the product in antistatic pouch in room temperature, because of avoidance for dusts and sunlight, if customer stores the product.
- ② In order to prevent dew condensation occurring by temperature difference, the product packing box must be opened after leave under the environment of an unpacking room temperature enough. Because a situation of dew condensation occurring is changed by the environment temperature and humidity, evaluate the leaving time sufficiently. (Recommendation leaving time: 6 hour or more with packing state)
- ③ Do not operate in a high magnetic field .Circuit boards may be broken down by it.
- ④ This product is not designed as radiation hardened.
- ⑤ Use an original protection sheet on the product surface (polarizer). Adhesive type protection sheet should be avoided, because it may change color or properties of the polarizer.

13.3 Characteristics

The following items are neither defects nor failures.

- ① Response time, luminance and color may be changed by ambient temperature.
- ②The LCD may be seemed luminance non-uniformity, flicker, vertical seam or small spot by display patterns.
- ③Optical characteristics (e.g. luminance, display uniformity, etc.) gradually is going to change depending on operating time ,and especially low temperature, because the LCD has cold cathode fluorescent lamps.
- ④Do not display the fixed pattern for a long time because it may cause image sticking .Use a screen saver, if the fixed pattern is displayed on the screen.
- ⑤The display color may be changed by viewing angle because of the use of condenser sheet in the backlight.
- ⑥Optical characteristics may be changed by input signal timings.
- ⑦The interference noise of input signal frequency for this product and luminance control frequency of customer's backlight inverter may appear on a display. Set up luminance control frequency of backlight inverter so that the interference noise doses not appear.

13.4 Other

- ①All GND and VCC terminals should be used without a non-connected line.
- ②Do not disassemble a product or adjust volume without permission of SCO.
- ③Pay attention not to insert waste materials inside of products, if customer uses screw nails.
- ④Pack the product with original shipping package, because of avoidance of some damages during transportation, when customer returns it to SCO for repair and so on .
- ⑤Not only the module but also the equipment should be packed and transported as the module. becomes vertical .Otherwise, there is the fear that a display dignity decreases by an impact or vibrations.

14.OUTDRAWING

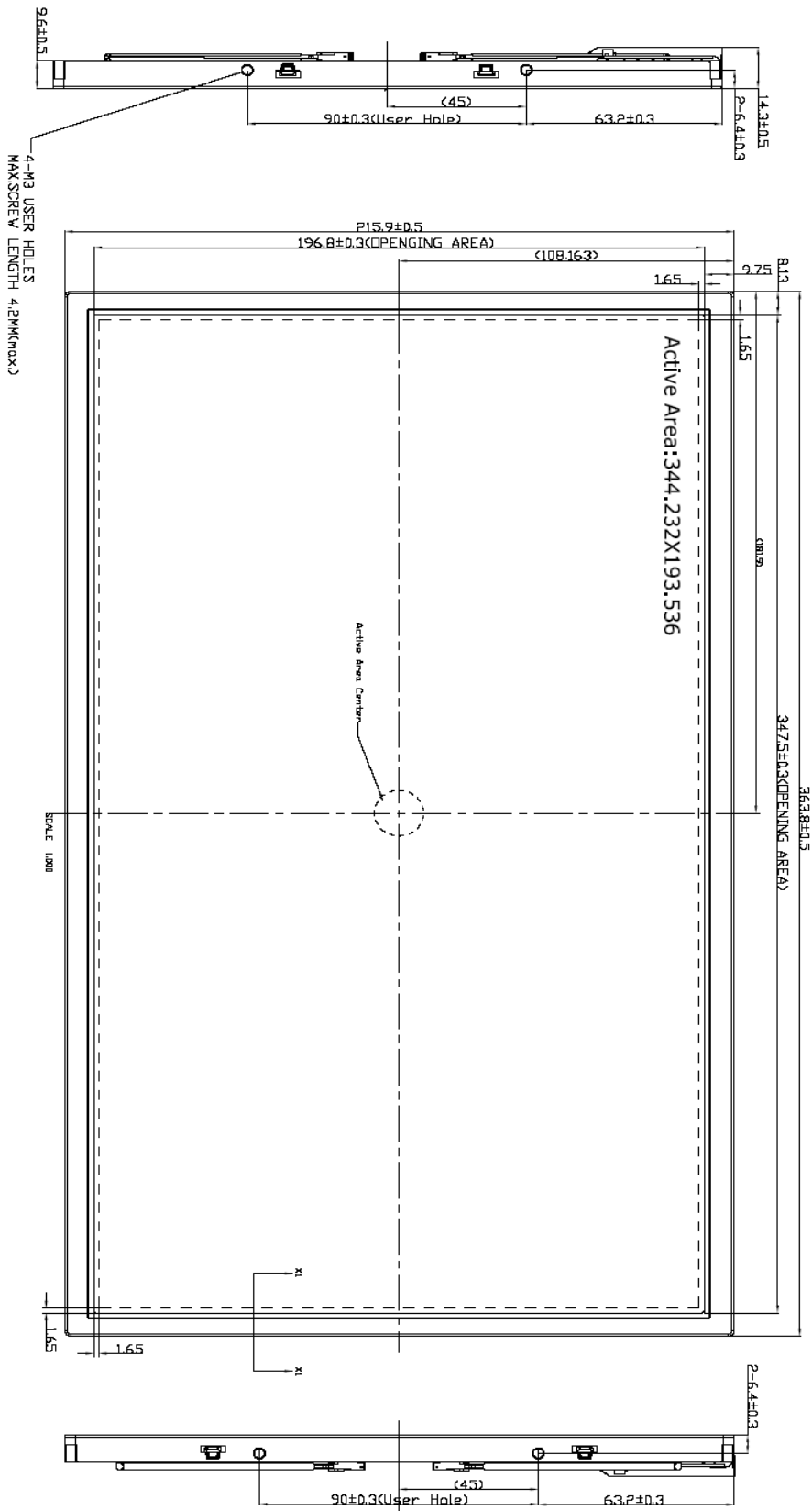

Note:
 1. BULK LIGHT : 2 COLA CATHODE FLUORESCENT LAMPS.
 2. I/F CONNECTOR SPECIFICATION
 3. POWER SUPPLY : 24VDC
 4. LAMP CONNECTOR SPECIFICATION
 5. MAXIMUM TEMPERATURE : 40°C
 6. LIFETIME : 10000 HOURS
 7. ALL DIMENSIONS IN MILLIMETERS UNLESS OTHERWISE SPECIFIED

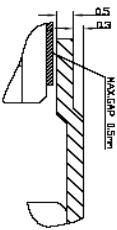





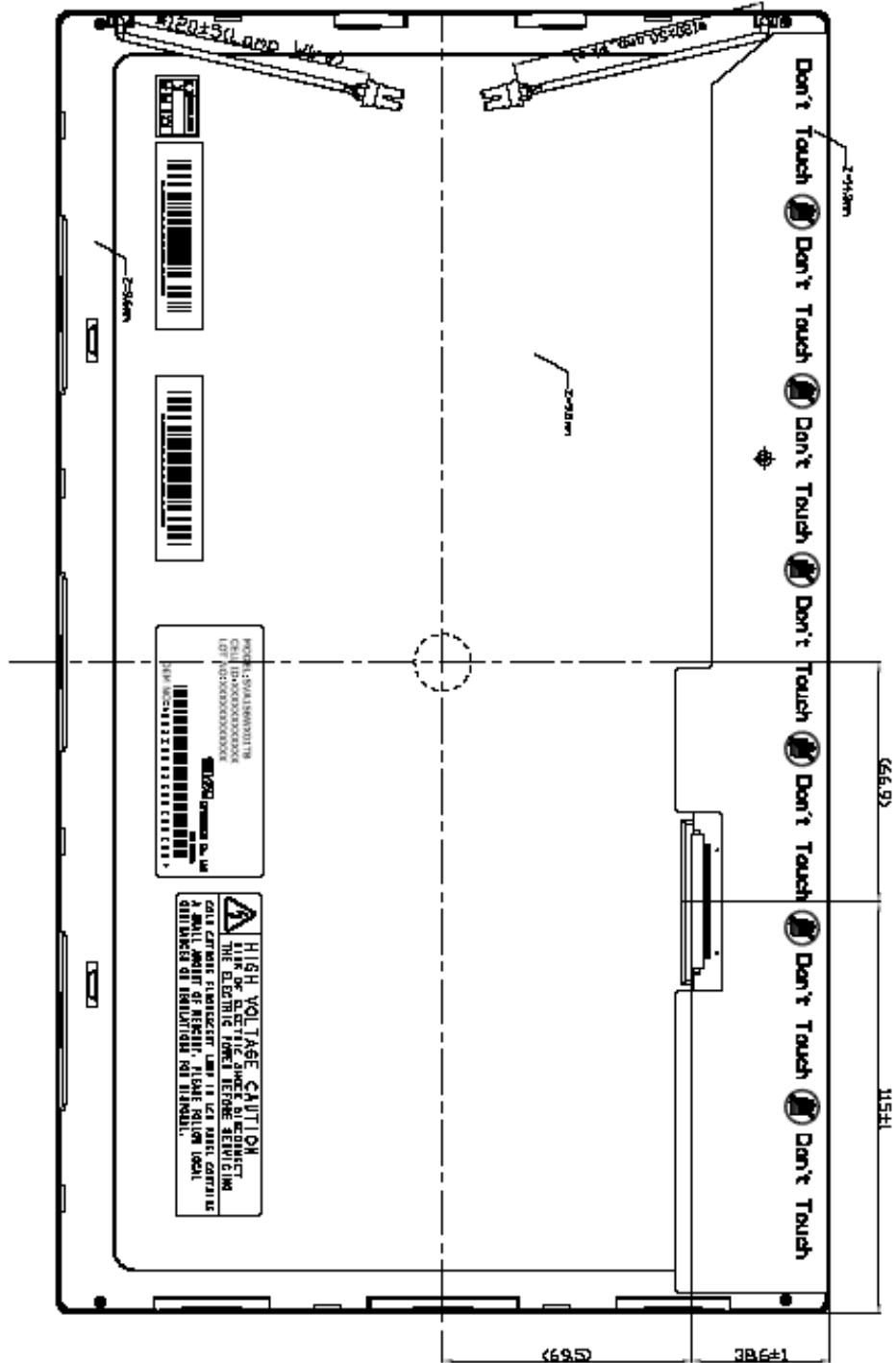

SECTION X1-X1
 SCALE 1:1

SVA OPTRONICS Co., Ltd.



- Note:
 1.BACKLIGHT : 2 COLD CATHODE FLUORESCENT LAMPS.
 2.I/F CONNECTOR SPECIFICATION
 -MAKER: HIRISE
 -PART NO: M0F760W-S0S-3K(SB)
 3.LAMP CONNECTOR SPECIFICATION
 -MAKER: YEDIND
 -PART NO: 3500JHS-02L
 4.IRESR MOUNTING TORQUE: SPEC54kgf-cm

Rev	Revised date	Main Revision item and sign	Approved by	Checked by	Prepared by	Published date												
1.0	2009-12-22	<p style="text-align: center;">New publication</p> <table border="1" style="width: 100%; border-collapse: collapse;"> <tr> <td style="width: 20%;"></td> <td style="width: 15%; text-align: center;">品管</td> <td style="width: 15%; text-align: center;">营业</td> <td style="width: 15%;"></td> <td style="width: 15%;"></td> <td style="width: 15%;"></td> </tr> <tr> <td style="vertical-align: middle;">Sign</td> <td style="text-align: center;">  2009/12/22 </td> <td style="text-align: center;">  09/12/25 </td> <td></td> <td></td> <td></td> </tr> </table>		品管	营业				Sign	 2009/12/22	 09/12/25				Johnny Joun	Anfernee Du	Chen Haoyuan	2009.12.22
	品管	营业																
Sign	 2009/12/22	 09/12/25																