



PRELIMINARY

8XC196MD INDUSTRIAL MOTOR CONTROL MICROCONTROLLER

87C196MD 16 Kbytes of On-Chip OTPROM*
87C196MD, ROM 16 Kbytes of On-Chip Factory-Programmed OTPROM
80C196MD ROMless

- High-Performance CHMOS 16-Bit CPU
- 16 Kbytes of On-Chip OTPROM/
Factory-Programmed OTPROM
- 488 bytes of On-Chip Register RAM
- Register to Register Architecture
- Up to 64 I/O Lines
- Peripheral Transaction Server (PTS)
with 17 Prioritized Sources
- Event Processor Array (EPA)
 - 6 High Speed Capture/Compare
Modules
 - 6 High Speed Compare Modules
- Extended Temperature Standard
- Programmable Frequency Generator
- Two 16-Bit Timers with Quadrature
Counting Input
- 3-Phase Complementary Waveform
Generator
- 14 Channel 8/10-Bit A/D with Sample/
Hold with Zero Offset Adjustment H/W
- 18 Prioritized Interrupt Sources
- Flexible 8-/16-Bit External Bus
- 1.75 μ s 16 x 16 Multiply
- 3 μ s 32/16 Divide
- Idle and Power Down Modes

The 8XC196MD is a 16-bit microcontroller designed primarily to control 3 phase AC induction and DC brushless motors. The 8XC196MD is based on Intel's MCS[®] 96 16-bit microcontroller architecture and is manufactured with Intel's CHMOS process.

The 8XC196MD has a three phase waveform generator specifically designed for use in "Inverter" motor control applications. This peripheral allows for pulse width modulation, three phase sine wave generation with minimal CPU intervention. It generates 3 complementary non-overlapping PWM pulses with resolutions of 0.125 μ s (edge trigger) or 0.250 μ s (centered).

The 8XC196MD has 16 Kbytes on-chip OTPROM?ROM and 488 bytes of on-chip RAM. It is available in two packages: PLCC (84-L) and EIAJ/QFP (80-L).

Operational characteristics are guaranteed over the temperature range of - 40°C to + 85°C.

The 87C196MD contains 16 Kbytes on-chip OTPROM. The 83C196MD contains 16 Kbytes on-chip ROM. All references to the 80C196MD also refers to the 83C196MD and 87C196MD unless noted.

*OTPROM (One Time Programmable Read Only Memory) is the same as EPROM but it comes in an unwindowed package and cannot be erased. It is user programmable.

*Other brands and names are the property of their respective owners.
Information in this document is provided in connection with Intel products. Intel assumes no liability whatsoever, including infringement of any patent or copyright, for sale and use of Intel products except as provided in Intel's Terms and Conditions of Sale for such products. Intel retains the right to make changes to these specifications at any time, without notice. Microcomputer Products may have minor variations to this specification known as errata.
COPYRIGHT © INTEL CORPORATION, 2004
July 2004
Order Number: 272323-003

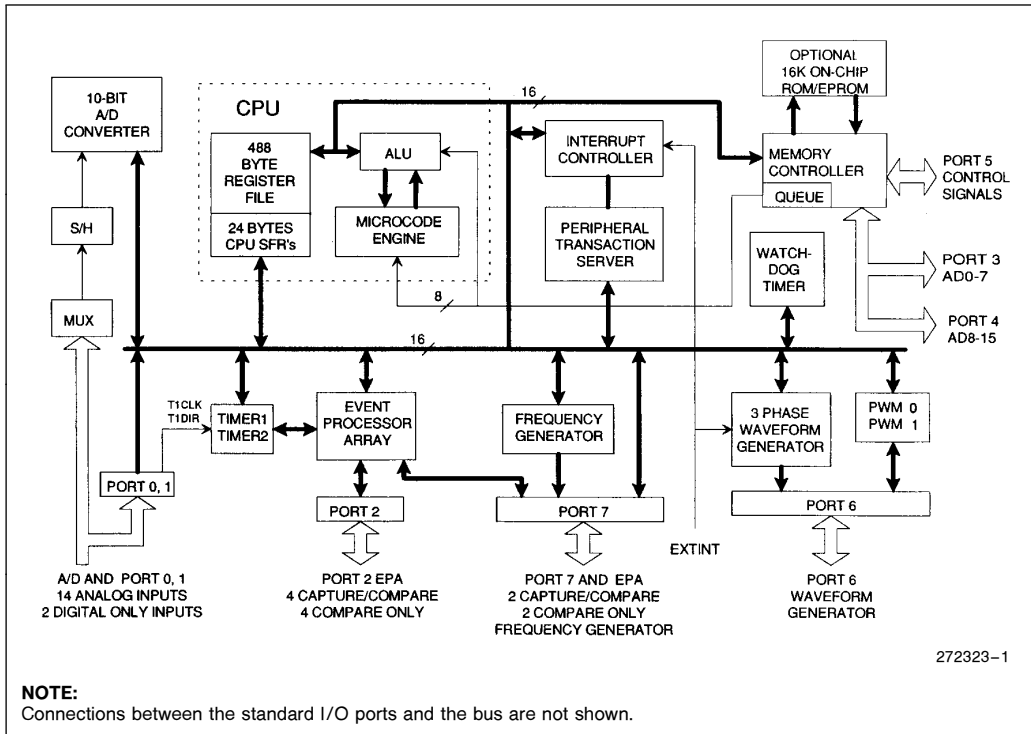

Figure 1. 87C196MD Block Diagram

PROCESS INFORMATION

This device is manufactured on PX29.5, a CHMOS III-E process. Additional process and reliability information is available in the *Intel® Quality System Handbook*.

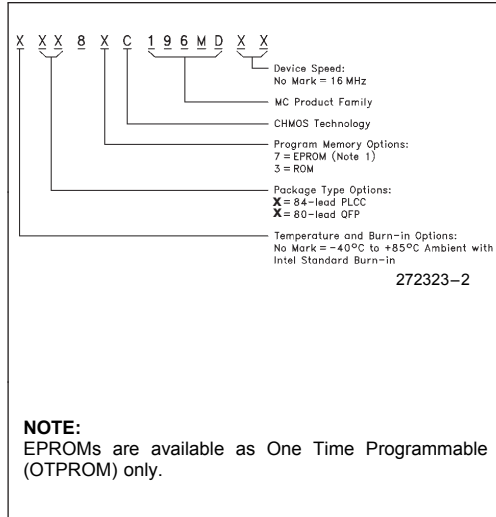

Figure 2. The 8XC196MD Family Nomenclature

Table 1. Thermal Characteristics

Package Type	θ_{ja}	θ_{jc}
PLCC	35°C/W	13 °C/W
QFP	56°C/W	12 °C/W

All thermal impedance data is approximate for static air conditions at 1W of power dissipation. Values will change depending on operation conditions and application. See the Intel *Packaging Handbook* (order number 240800) for a description of Intel's thermal impedance test methodology.

Table 2. 8XC196MD Memory Map

Description	Address
External Memory or I/O	0FFFFH 06000H
Internal ROM/EPROM or External Memory (Determined by $\bar{E}A$)	5FFFH 2080H
Reserved. Must contain FFH. (Note 5)	207FH 205EH
PTS Vectors	205DH 2040H
Upper Interrupt Vectors	203FH 2030H
ROM/EPROM Security Key	202FH 2020H
Reserved. Must contain FFH. (Note 5)	201FH 201CH
Reserved. Must Contain 20H (Note 5)	201BH
CCB1	201AH
Reserved. Must Contain 20H (Note 5)	2019H
CCB0	2018H
Reserved. Must contain FFH. (Note 5)	2017H 2014H
Lower Interrupt Vectors	2013H 2000H
SFR's	1FFFH 1F00H
External Memory	1EFFH 0200H
488 Bytes Register RAM (Note 1)	01FFFH 0018H
CPU SFR's (Notes 1. 3)	0017H 0000H

NOTES:

- Code executed in locations 0000H to 01FFFH will be forced external.
- Reserved memory locations must contain 0FFH unless noted.
- Reserved SFR bit locations must contain 0.
- Refer to 8XC196MC for SFR descriptions.
- WARNING:** Reserved memory locations must not be written or read. The contents and/or function of these locations may change with future revisions of the device. Therefore, a program that relies on one or more of these locations may not function properly.

8XC196MC AND 8XC196MD DIFFERENCES

INT_MASK1/INT_PEND1 Registers

There are some differences between the 8XC196MC and 8XC196MD INT_MASK1/INT_PEND1 registers. The 8XC196MD interrupt mask and pending registers are shown below. Notice that the CAPCOM5, COMP4, and CAPCOM4 bits are reserved bits on the 8XC196MC. The PI bit of the INT_PEND1 register will be set when a Waveform Generator or Compare Module 5 event occurs and the corresponding bit in the PI_MASK register is set. The PI interrupt vector can be taken when the PI bit in the INT_MASK1 register is set. The 8XC196MC User's Manual should be referenced for details about the interrupts.

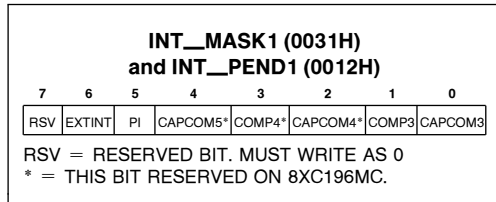

Figure 3. Interrupt Mask and Status Registers

PTSSRV and PTSEL Register

Similarly, there are differences between 8XC196MC and 8XC196MD PTS registers. The 8XC196MD PTS registers are shown below. Notice the CAPCOM5, COMP4, and CAPCOM4 bits are reserved bits on the 8XC196MC. The PI bit in the PTSSRV will be set when a Waveform Generator or Compare Module 5 end of PTS interrupt occurs and the corresponding bit in the PI_MASK register is set. The PI PTS vector can be used when the PI bit in the PTSEL register is set. The 8XC196MC User's Manual should be referenced for details about the PTS.

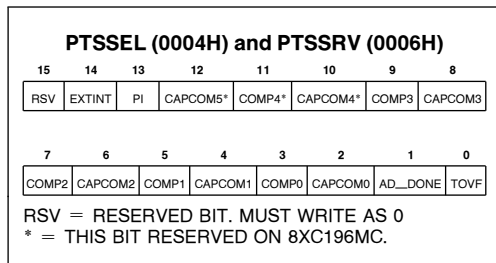

Figure 4. PTS Select and Service Registers

PI_MASK and PI_PEND Registers

The PI_MASK/PI_PEND registers contain the bits for the Compare Module 5 (COMP5) Waveform Generator (WG), Timer 1 Overflow (TF1), and Timer 2 Overflow (TF2) mask/status flag. The diagram below shows the registers. Notice that the COMP5 bit is a reserved bit on the 8XC196MC. The 8XC196MC User's Manual should be referenced for details about the Waveform Generator, Compare Modules, and Timers.

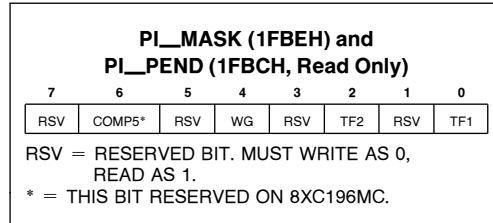

Figure 5. Peripheral Interrupt Mask and Status Registers

The PI bit in the INT_PEND1 register is set if a Waveform Generator event or Compare Module 5 event occurs and the corresponding PI_MASK bit is set. For either of these events to cause an interrupt, the PI bit in the INT_MASK1 register and the corresponding event bit in the PI_MASK register must be set.

Similarly, the TOVF bit in the INT_PEND register is set if Timer 1 or Timer 2 overflow and the corresponding bit in the PI_MASK register is set. For either of these two events to cause an interrupt, the TOVF bit in the INT_MASK1 register and the corresponding event bit in the PI_MASK must be set.

Upon a PI and/or a TOVF interrupt, it may be necessary to check if the Compare Module 5, the Waveform Generator, Timer 1, or Timer 2 event caused the interrupt. The PI_PEND will give this information. However, it should be noted that reading the PI_PEND register will clear the register. So the individual bits in the PI_PEND register must be read by loading PI_PEND into another "shadow" register, then checking the "shadow" register to see what event occurred.

Table 3. Interrupt Sources, Vectors and Priorities

Interrupt Source	Symbol	Interrupt Service			PTS Service		
		Name	Vector	Priority	Name	Vector	Priority
Capture/Compare5	CAPCOMP5	INT12	2038H	12	PTS12	2058H	27
Compare4	COMP4	INT11	2036H	11	PTS11	2056H	26
Capture/Compare4	CAPCOMP4	INT10	2034H	10	PTS10	2054H	25

Interrupt and PTS Vectors

The 8XC196MD has three new interrupt and PTS vectors which are Capture/Compare5, Compare 4, and Capture/Compare4. Table 3 shows these interrupt vectors and priorities. These are shown as reserved vectors in the 8XC196MC User's Manual.

Port 7

Port 7 is an additional bidirectional port that was not available on the 8XC196MC device. Port 7 can be used as I/O or some of the pins have special functions. The pins are listed below followed by their special functions.

Frequency Generator

The Frequency Generator (FG) Peripheral which was not available on the 8XC196MC device, is available on the 8XC196MD device. The FG outputs a programmable-frequency 50% duty cycle waveform on the FREQOUT pin (P7.7). There are two 8-bit registers which control the FG peripheral:

- Frequency Generator Control Register (FG_CON) at 1FB8h
- Frequency Generator Period Count Register (FG_COUNT) at 1FBAh.

The FG_CON can be read or written. This register is loaded with a value which determines the number of counts necessary for toggling the output. The following equation should be used to calculate the FG_CON value:

$$FG_CON \text{ value} = \frac{F_{XTAL}}{16 * (FG \text{ Frequency})} - 1$$

where FG Frequency is from 4 kHz to 1 MHz.

The FG_COUNT is loaded with the FG_CON register value. The FG_COUNT register is decremented every eighth state time. When it reaches 00h, the FG_COUNT register will send a signal to toggle the output pin and reload the FG_COUNT register with the value in the FG_CON register. The FG_COUNT can only be read, not written.

The FREQOUT pin (P7.7) must be configured for a special function to use it for the Frequency Generator feature.

Table 4. Port 7 Special Function Pins

Pin	Special Function
P7.0	CAPCOMP4
P7.1	CAPCOMP5
P7.2	CAPCOMP4
P7.3	CAPCOMP5
P7.4	
P7.5	
P7.6	
P7.7	FREQOUT

The special functions of the pins are selected in the Port 7 SFRs. The Port 2 I/O Port section of the 8XC196MC User's Manual can be referenced when setting up the Port 7 SFRs. Port 7 SFRs are located in the following locations:

Table 5. Port 7 Special Function Registers

SFR	Address
P7__MODE	1FD1h
P7__DIR	1FD3h
P7__REG	1FD5h
P7__PIN	1FD7h



Port 1

There are three additional Port 1 input pins (P1.5–P1.7) that were not available on the 8XC196MC. These pins are listed below followed by their function:

Table 6. New 8XC196MD Port 1 Pins

Pin	Description
P1.5	Digital or Analog Input
P1.6	Digital Input
P1.7	Digital Input

NOTE:

P1.5 was a V_{SS} pin on the 8XC196MC device. If P1.5 and P1.6 are not being used these pins can remain connected to V_{SS} .

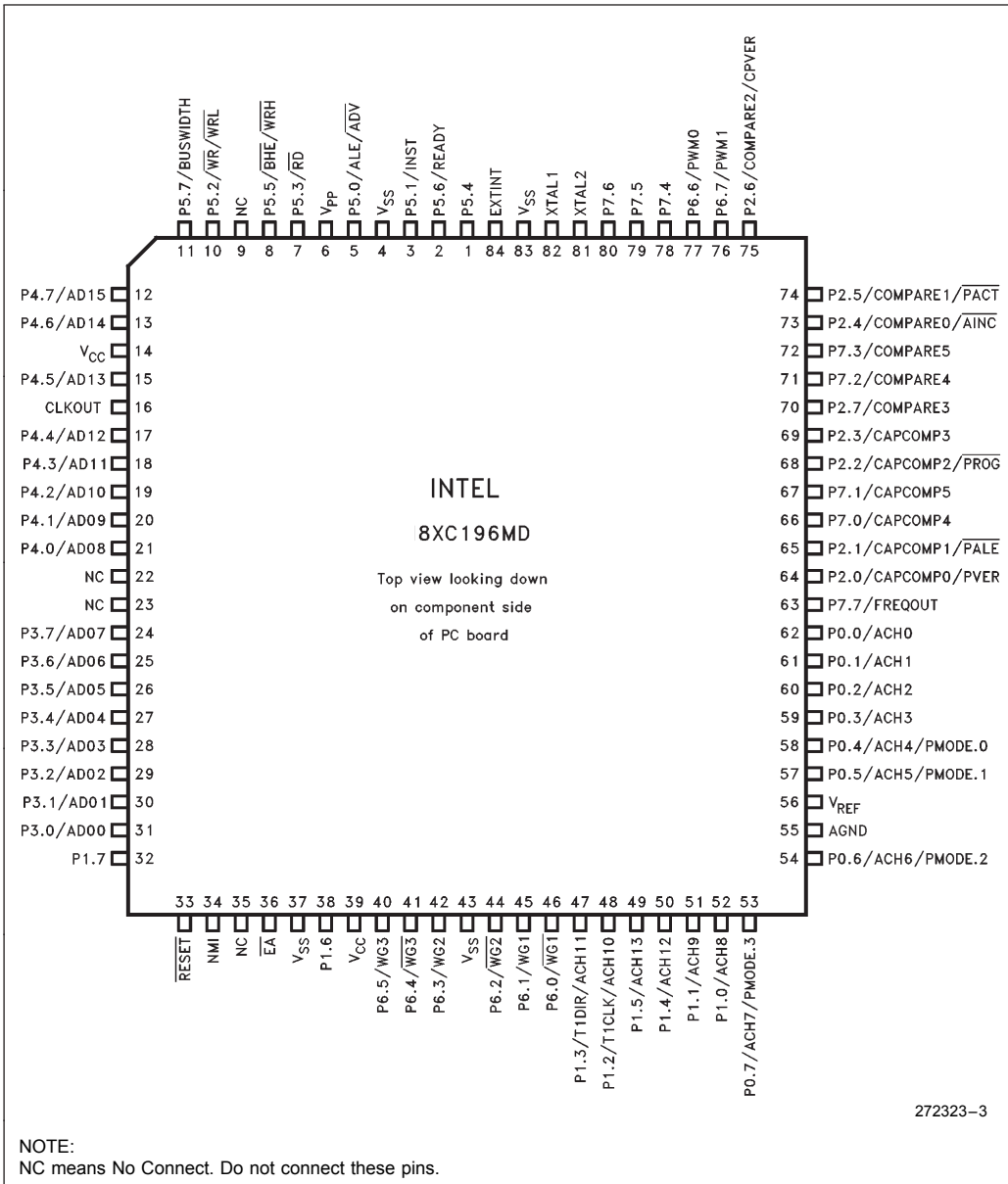

Figure 6. 84-Lead PLCC Package

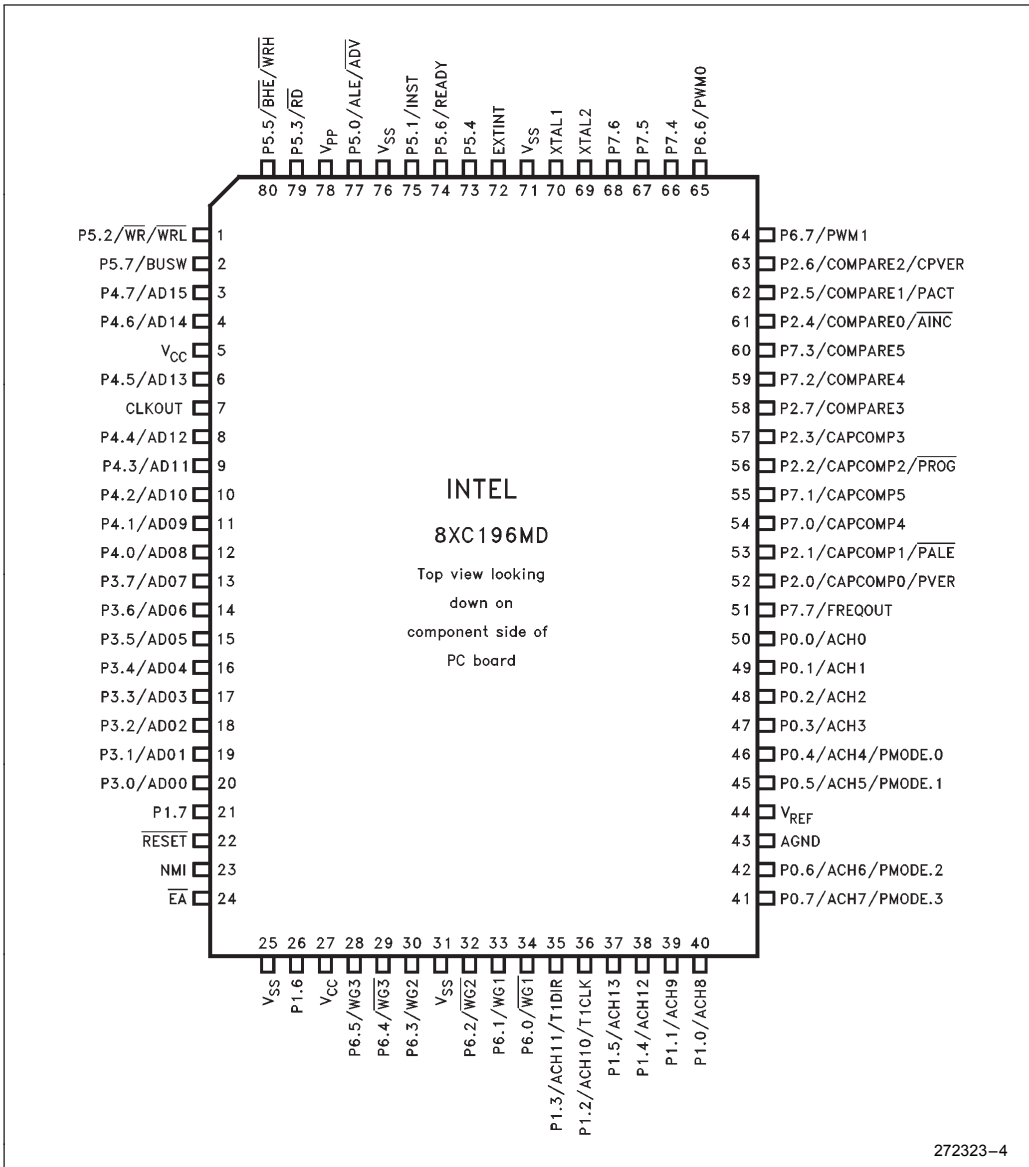

Figure 7. 80-Lead Shrink EIAJQFP (Quad Flat Pack)

272323-4

PIN DESCRIPTIONS (Alphabetically Ordered)

Symbol	Function
ACH0–ACH13 (P0.0–P0.7, P1.0–P1.5)	Analog inputs to the on-chip A/D converter. ACH0–7 share the input pins with P0.0–7 and ACH8–13 share pins with P1.0–5. If the A/D is not used, the port pins can be used as standard input ports.
ANGND	Reference ground for the A/D converter. Must be held at nominally the same potential as V_{SS} .
ALE/ \overline{ADV} (P5.0)	Address Latch Enable or Address Valid output, as selected by CCR. Both options allow a latch to demultiplex the address/data bus on the signal's falling edge. When the pin is \overline{ADV} , it goes inactive (high) at the end of the bus cycle. ALE/ \overline{ADV} is active only during external memory accesses. Can be used as standard I/O when not used as ALE/ \overline{ADV} .
\overline{BHE} / \overline{WRH} (P5.5)	Byte High Enable or Write High output, as selected by the CCR. \overline{BHE} will go low for external writes to the high byte of the data bus. \overline{WRH} will go low for external writes where an odd byte is being written. $\overline{BHE}/\overline{WRH}$ is activated only during external memory writes.
BUSWIDTH (P5.7)	Input for bus width selection. If CCR bits 1 and 2 = 1, this pin dynamically controls the bus width of the bus cycle in progress. If BUSWIDTH is low, an 8-bit cycle occurs. If it is high, a 16-bit cycle occurs. This pin can be used as standard I/O when not used as BUSWIDTH.
CAPCOMP0–CAPCOMP5 (P2.0–P2.3, P7.0–P7.1)	The EPA Capture/Compare pins. CAPCOMP0–3 share the pins with P2.0–P2.3. CAPCOMP4–5 share the pins with P7.0–P7.1. If not used for the EPA, they can be configured as standard I/O pins.
CLKOUT	Output of the internal clock generator. The frequency is $\frac{1}{2}$ of the oscillator frequency. It has a 50% duty cycle.
COMPARE0–COMPARE5 (P2.4–P2.7, P7.2–P7.3)	The EPA Compare pins. COMPARE0–3 share the pins with P2.4–P2.7. COMPARE4–5 share the pins with P7.2–P7.3. If not used for the EPA, they can be configured as standard I/O pins.
\overline{EA}	External Access enable pin. $\overline{EA} = 0$ causes all memory accesses to be external to the chip. $\overline{EA} = 1$ causes memory accesses from location 2000H to 5FFFH to be from the on-chip OTPROM/ROM. $\overline{EA} = 12.5V$ causes execution to begin in the programming mode. \overline{EA} is latched at reset.
EXTINT	A programmable input on this pin causes a maskable interrupt vector through memory location 203CH. The input may be selected to be a positive/negative edge or a high/low level using WG_PROTECT (1FCEH).
FREQOUT	Programmable frequency output pin. The frequency can vary from 4 KHz to 1 MHz (16 MHz input clock). It has a 50% duty cycle. Pin may be configured as standard I/O if FREQOUT is not used.
INST (P5.1)	INST is high during the instruction fetch from the external memory and throughout the bus cycle. It is low otherwise. This pin can be configured as standard I/O if not used as INST.
NMI	A positive transition on this pin causes a non-maskable interrupt which vectors to memory location 203EH. If not used, it should be tied to V_{SS} . May be used by Intel Evaluation boards.
PORT0	8-bit high impedance input-only port. Also used as A/D converter inputs. Port0 pins should not be left floating. These pins also used to select programming modes in the OTPROM devices.
PORT1	8-bit high impedance input-only port. P1.0–P1.5 are also used as A/D converter inputs. In addition, P1.2 and P1.3 can be used as Timer 1 clock input and direction select respectively. P1.6–P1.7 can be used as input-only pins.

PIN DESCRIPTIONS (Alphabetically Ordered) (Continued)

Symbol	Function
PORT2	8-bit bidirectional I/O port. All of the Port2 pins are shared with the EPA I/O pins (CAPCOMP0–3 and COMPARE0–3).
PORT3 PORT4	8-bit bidirectional I/O ports with open drain outputs. These pins are shared with the multiplexed address/data bus which uses strong internal pullups.
PORT5	8-bit bidirectional I/O port. 7 of the pins are shared with bus control signals (ALE, INST, WR, RD, BHE, READY, BUSWIDTH). Can be used as standard I/O.
PORT6	8-bit output port. P6.6 and P6.7 output PWM, the others are used as the Wave Form Generator outputs. Can be used as standard output ports.
PORT7	8-bit bidirectional I/O port. P7.0–P7.3 can be used as EPA I/O pins (CAPCOMP4–5 and COMPARE4–5). P7.7 can be used as FREQOUT output pin. P7.4–P7.6 are standard I/O pins.
PWM0, PWM1 (P6.6, P6.7)	Programmable duty cycle, Programmable frequency Pulse Width Modulator pins. The duty cycle has a resolution of 256 steps, and the frequency can vary from 122 Hz to 31 KHz (16 MHz input clock). Pins may be configured as standard output if PWM is not used.
\overline{RD} (P5.3)	Read signal output to external memory. \overline{RD} is low only during external memory reads. Can be used as standard I/O when not used as \overline{RD} .
READY (P5.6)	Ready input to lengthen external memory cycles. If READY = 0, the memory controller inserts wait states until the next positive transition of CLKOUT occurs with READY = 1. Can be used as standard I/O when not used as READY.
\overline{RESET}	Reset input to and open-drain output from the chip. Held low for at least 16 state times to reset the chip. Input high for normal operation. \overline{RESET} has an Ohmic internal pullup resistor.
T1CLK (P1.2)	Timer 1 Clock input. This pin has two other alternate functions: ACH10 and P1.2.
T1DIR (P1.3)	Timer 1 Direction input. This pin has two other alternate functions: ACH11 and P1.3.
V _{pp}	The programming voltage is applied to this pin. It is also the timing pin for the return from Power Down circuit. Connect this pin with a 1 μ F capacitor to V _{SS} and a 1 M Ω resistor to V _{CC} . If the Power Down feature is not used, connect the pin to V _{CC} .
WG1–WG3/ $\overline{WG1}$ – $\overline{WG3}$ (P6.0–P6.5)	3 phase output signals and their complements used in motor control applications. The pins can also be configured as standard output pins.
WR/ \overline{WRL} (P5.2)	Write and Write Low output to external memory. \overline{WR} will go low every external write. \overline{WRL} will go low only for external writes to an even byte. Can be used as standard I/O when not used as WR/ \overline{WRL} .
XTAL1	Input of the oscillator inverter and the internal clock generator. This pin should be used when using an external clock source.
XTAL2	Output of the oscillator inverter.
PMODE (P0.4–7)	Determines the EPROM programming mode.
\overline{PACT} (P2.5)	A low signal in Auto Programming mode indicates that programming is in process. A high signal indicates programming is complete.

PIN DESCRIPTIONS (Alphabetically Ordered) (Continued)

Symbol	Function
$\overline{\text{PALE}}$ (P2.1)	A falling edge in Slave Programming Mode and Auto Configuration Byte Programming Mode indicates that ports 3 and 4 contain valid programming address/command information (input to slave).
$\overline{\text{PROG}}$ (P2.2)	A falling edge in Slave Programming Mode begins programming. A rising edge ends programming.
$\overline{\text{PVER}}$ (P2.0)	A high signal in Slave Programming Mode and Auto Configuration Byte Programming Mode indicates the byte programmed correctly.
$\overline{\text{CPVER}}$ (P2.6)	Cumulative Program Verification. Pin is high if all locations since entering a programming mode have programmed correctly.
$\overline{\text{AINC}}$ (P2.4)	Auto Increment. Active low input enables the auto increment mode. Auto increment will allow reading or writing of sequential EPROM locations without address transactions across the PBUS for each read or write.

ABSOLUTE MAXIMUM RATINGS

Ambient Temperature	
Under Bias	−40°C to +85°C
Storage Temperature	−65°C to +150°C
Voltage from \overline{EA} or V_{PP}	
to V_{SS} or ANGND	−0.5V to +13.00V
Voltage on Any Other Pin	
to V_{SS} or ANGND	−0.5V to +7.0V(1)
Power Dissipation	1.5W(2)

NOTES:

1. This includes V_{PP} and \overline{EA} on ROM or CPU only devices.
2. Power dissipation is based on package heat transfer limitations, not device power consumption.

NOTICE: This data sheet contains preliminary information on new products in production. The specifications are subject to change without notice. Verify with your local Intel Sales office that you have the latest data sheet before finalizing a design.

**WARNING: Stressing the device beyond the "Absolute Maximum Ratings" may cause permanent damage. These are stress ratings only. Operation beyond the "Operating Conditions" is not recommended and extended exposure beyond the "Operating Conditions" may affect device reliability.*

OPERATING CONDITIONS

Symbol	Description	Min	Max	Units
T_A	Ambient Temperature Under Bias	−40	+85	°C
V_{CC}	Digital Supply Voltage	4.50	5.50	V
V_{REF}	Analog Supply Voltage	4.00	5.50	V
F_{OSC}	Oscillator Frequency	8	16	MHz

NOTE:

ANGND and V_{SS} should be nominally at the same potential. Also V_{SS} and V_{SS1} must be at the same potential.

DC ELECTRICAL CHARACTERISTICS (Over Specified Operating Conditions)

Symbol	Parameter	Min	Max	Units	Test Conditions
V_{IL}	Input Low Voltage	−0.5	$0.3 V_{CC}$	V	
V_{IH}	Input High Voltage	$0.7 V_{CC}$	$V_{CC} + 0.5$	V	
V_{OL}	Output Low Voltage Port 2, 5, and 7, P6.6, P6.7, CLKOUT		0.3 0.45 1.5	V V V	$I_{OL} = 200 \mu A$ $I_{OL} = 3.2 \text{ mA}$ $I_{OL} = 7 \text{ mA}$
V_{OL1}	Output Low Voltage on Port 3/4		1.0	V	$I_{OL} = 15 \text{ mA}$
V_{OL2}	Output Low Voltage on Port 6.0–6.5		0.45	V	$I_{OL} = 10 \text{ mA}$
V_{OH}	Output High Voltage	$V_{CC} - 0.3$ $V_{CC} - 0.7$ $V_{CC} - 1.5$		V V V	$I_{OH} = -200 \mu A$ $I_{OH} = -3.2 \text{ mA}$ $I_{OH} = -7 \text{ mA}$
$V_{th+} - V_{th-}$	Hysteresis Voltage Width on RESET	0.2		V	Typical

DC ELECTRICAL CHARACTERISTICS (Over Specified Operating Conditions) (Continued)

Symbol	Parameter	Min	Typ	Max	Units	Test Conditions
I _{LI}	Input Leakage Current on All Input Only Pins			±10	μA	0V < V _{IN} < V _{CC} -0.3V (in RESET)
I _{LI1}	Input Leakage Current on Port0 and Port1			±3	μA	0V < V _{IN} < V _{REF}
I _{IL}	Input Low Current on BD Ports (Note 1)			-70	μA	V _{IN} = 0.3 V _{CC}
I _{IL1}	Input Low Current on P5.4 and P2.6 during Reset (Note 3)			-10	mA	0.2 V _{CC}
I _{OH}	Output High Current on P5.4 and P2.6 during Reset (Note 4)	-2			mA	0.7 V _{CC}
I _{CC}	Active Mode Current in Reset		50	70	mA	XTAL1 = 16 MHz, V _{CC} = V _{PP} = V _{REF} = 5.5V
I _{REF}	A/D Conversion Reference Current		2	5	mA	
I _{IDL}	Idle Mode Current		15	30	mA	V _{CC} = V _{PP} = V _{REF} = 5.5V
I _{PD}	Power-Down Mode Current		5	50	μA	
R _{RST}	RESET Pin Pullup Resistor	6k		65k	Ω	
C _S	Pin Capacitance (Any Pin to V _{SS})			10	pF	F _{TEST} = 1.0 MHz

NOTES:

- BD (Bidirectional ports) include:
 - P2.0–P2.7, except P2.6
 - P3.0–P3.7
 - P4.0–P4.7
 - P5.0–P5.3
 - P5.5–P5.7
 - P7.0–P7.7
- During normal (non-transient) conditions, the following total current limits apply:

P6.0–P6.5	I _{OL} : 40 mA	I _{OH} : 28 mA
P3	I _{OL} : 90 mA	I _{OH} : 42 mA
P4	I _{OL} : 90 mA	I _{OH} : 42 mA
P5, CLKOUT	I _{OL} : 35 mA	I _{OH} : 35 mA
P2, P6.6, P6.7, P7	I _{OL} : 63 mA	I _{OH} : 63 mA
- Maximum current that must be sunk by external device to ensure test mode entry.
- Do not exceed minimum current or device may enter test mode.

EXPLANATION OF AC SYMBOLS

Each symbol is two pairs of letters prefixed by "T" for time. The characters in a pair indicate a signal and its condition, respectively. Symbols represent the time between the two signal/condition points.

Conditions:

H — High
 L — Low
 V — Valid
 X — No Longer Valid
 Z — Floating

Signals:

A — Address
 B — \overline{BHE}
 C — CLKOUT
 D — DATA
 G — Buswidth
 H — HOLD
 HA — \overline{HLDA}
 L — ALE/ \overline{ADV}
 BR — \overline{BREQ}
 R — \overline{RD}
 W — $\overline{WR}/\overline{WRH}/\overline{WRL}$
 X — XTAL1
 Y — READY
 Q — Data Out

AC ELECTRICAL CHARACTERISTICS (Over Specified Operating Conditions)

Test Conditions: Capacitive load on all pins = 100 pF, Rise and fall times = 10 ns, $F_{OSC} = 16$ MHz.

The system must meet the following specifications to work with the 87C196MD:

Symbol	Parameter	Min	Max	Units	Notes
FXTAL	Frequency on XTAL1	8	16	MHz	3
T _{OSC}	1/FXTAL	62.5	125	ns	
T _{AVYV}	Address Valid to READY Setup		2 T _{OSC} - 75	ns	
T _{LLYV}	ALE Low to READY Setup		T _{OSC} - 70	ns	4
T _{YLYH}	Not READY Time	No Upper Limit		ns	
T _{CLYX}	READY Hold after CLKOUT Low	0	T _{OSC} - 30	ns	1
T _{LLYX}	READY Hold after ALE Low	T _{OSC} - 15	2 T _{OSC} - 40	ns	1
T _{AVGV}	Address Valid to BUSWIDTH Setup		2 T _{OSC} - 75	ns	
T _{LLGV}	ALE Low to BUSWIDTH Setup		T _{OSC} - 60	ns	4
T _{CLGX}	Buswidth Hold after CLKOUT Low	0		ns	
T _{AVDV}	Address Valid to Input Data Valid		3 T _{OSC} - 55	ns	2
T _{RLDV}	\overline{RD} Active to Input Data Valid		T _{OSC} - 22	ns	2
T _{CLDV}	CLKOUT Low to Input Data Valid		T _{OSC} - 50	ns	
T _{RHDZ}	End of \overline{RD} to Input Data Float		T _{OSC}	ns	
T _{RDX}	Data Hold after \overline{RD} Inactive	0		ns	

NOTES:

1. If Max is exceeded, additional wait states will occur.
2. If wait states are used, add 2 T_{OSC} * N, where N = number of wait states.
3. Testing performed at 8 MHz. However, the device is static by design and will typically operate below 1 Hz.
4. These timings are included for compatibility with older -90 and BH products. They should not be used for newer high-speed designs.

AC ELECTRICAL CHARACTERISTICS (Continued)

 Test Conditions: Capacitive load on all pins = 100 pF, Rise and fall times = 10 ns, $F_{OSC} = 16$ MHz.

The 87C196MD will meet the following timing specifications:

Symbol	Parameter	Min	Max	Units	Notes
T_{XHCH}	XTAL1 to CLKOUT High or Low	30	110	ns	
T_{CLCL}	CLKOUT Cycle Time	$2 T_{OSC}$		ns	
T_{CHCL}	CLKOUT High Period	$T_{OSC} - 10$	$T_{OSC} + 15$	ns	
T_{CLLH}	CLKOUT Falling Edge to ALE Rising	-5	15	ns	
T_{LLCH}	ALE Falling Edge to CLKOUT Rising	-20	15	ns	
T_{LHLH}	ALE Cycle Time	$4 T_{OSC}$		ns	3
T_{LHLL}	ALE High Period	$T_{OSC} - 10$	$T_{OSC} + 10$	ns	
T_{AVLL}	Address Setup to ALE Falling Edge	$T_{OSC} - 15$		ns	
T_{LLAX}	Address Hold after ALE Falling	$T_{OSC} - 40$		ns	
T_{LLRL}	ALE Falling Edge to \overline{RD} Falling	$T_{OSC} - 30$		ns	
T_{RLCL}	\overline{RD} Low to CLKOUT Falling Edge	4	30	ns	
T_{RLRH}	\overline{RD} Low Period	$T_{OSC} - 5$	$T_{OSC} + 25$	ns	3
T_{RHLLH}	\overline{RD} Rising Edge to ALE Rising Edge	T_{OSC}	$T_{OSC} + 25$	ns	1
T_{RLAZ}	\overline{RD} Low to Address Float		5	ns	
T_{LLWL}	ALE Falling Edge to \overline{WR} Falling	$T_{OSC} - 10$		ns	
T_{CLWL}	CLKOUT Low to \overline{WR} Falling Edge	0	25	ns	
T_{QVWH}	Data Stable to \overline{WR} Rising Edge	$T_{OSC} - 23$		ns	
T_{CHWH}	CLKOUT High to \overline{WR} Rising Edge	-10	15	ns	
T_{WLWH}	\overline{WR} Low Period	$T_{OSC} - 30$		ns	3
T_{WHQX}	Data Hold after \overline{WR} Rising Edge	$T_{OSC} - 25$		ns	
T_{WHLH}	\overline{WR} Rising Edge to ALE Rising Edge	$T_{OSC} - 10$	$T_{OSC} + 15$	ns	1
T_{WHBX}	\overline{BHE} , INST Hold after \overline{WR} Rising	$T_{OSC} - 10$		ns	
T_{WHAX}	AD8-15 Hold after \overline{WR} Rising	$T_{OSC} - 30$		ns	2
T_{RHBX}	\overline{BHE} , INST Hold after \overline{RD} Rising	$T_{OSC} - 10$		ns	
T_{RHAX}	AD8-15 Hold after \overline{RD} Rising	$T_{OSC} - 30$		ns	2

NOTES:

1. Assuming back to back cycles.
2. 8-bit bus only.
3. If wait states are used, add $2 T_{OSC} * N$, where N = number of wait states.

SYSTEM BUS TIMINGS

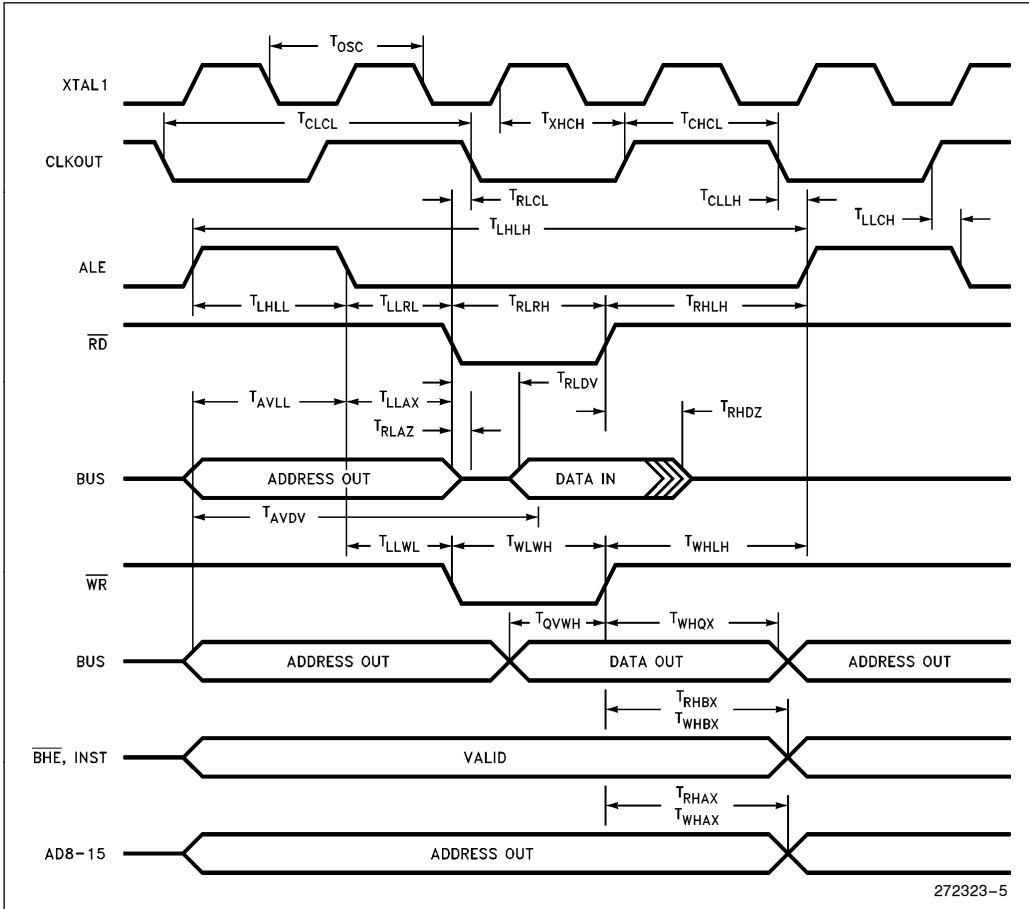

READY TIMINGS (One Wait State)

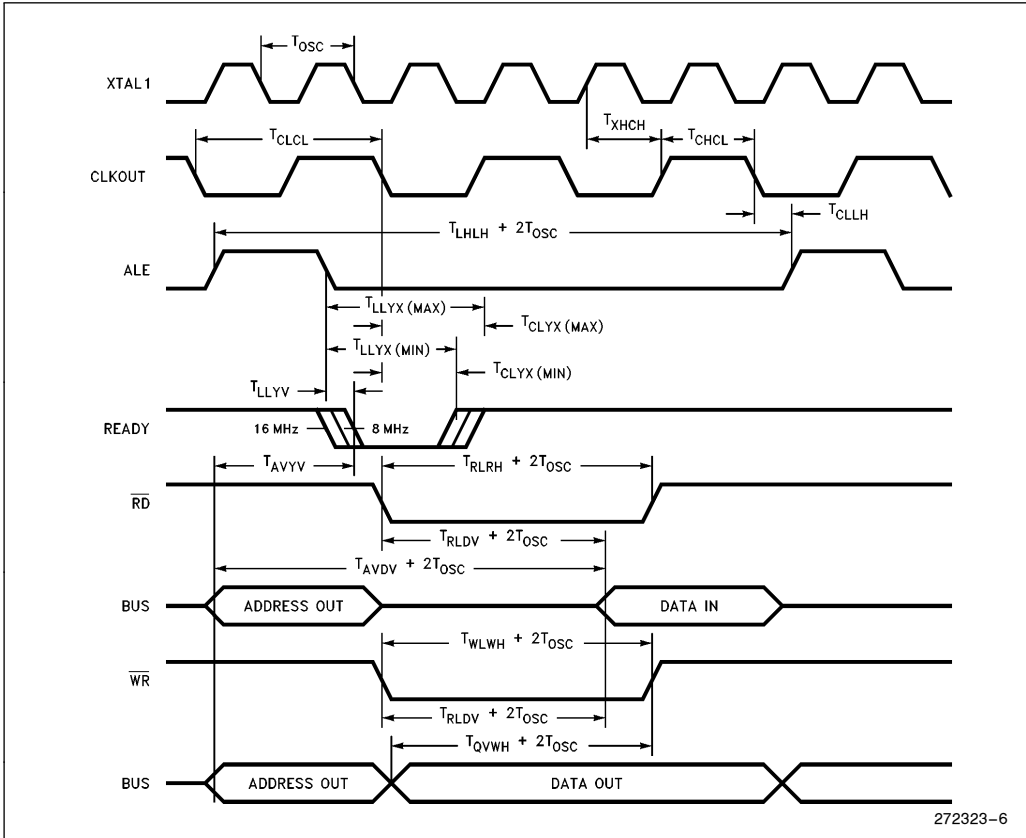

BUSWIDTH TIMINGS

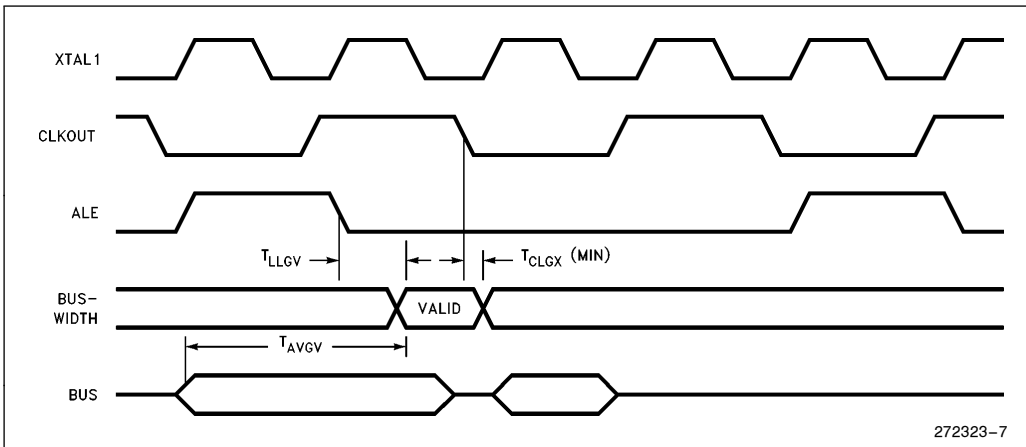

EXTERNAL CLOCK DRIVE

Symbol	Parameter	Min	Max	Units
$1/T_{XLXL}$	Oscillator Frequency	8	16.0	MHz
T_{XLXL}	Oscillator Period	62.5	125	ns
T_{XHXX}	High Time	22		ns
T_{XLXX}	Low Time	22		ns
T_{XLXH}	Rise Time		10	ns
T_{XHXL}	Fall Time		10	ns

EXTERNAL CRYSTAL CONNECTIONS

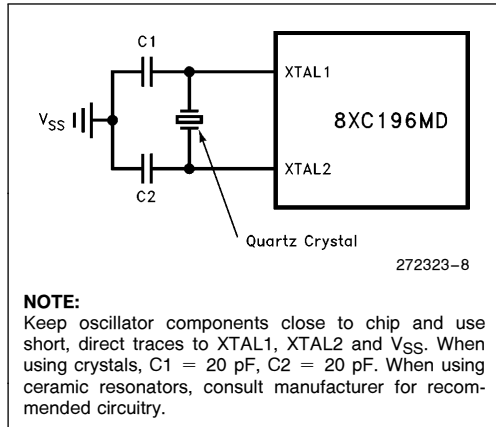

EXTERNAL CLOCK CONNECTIONS

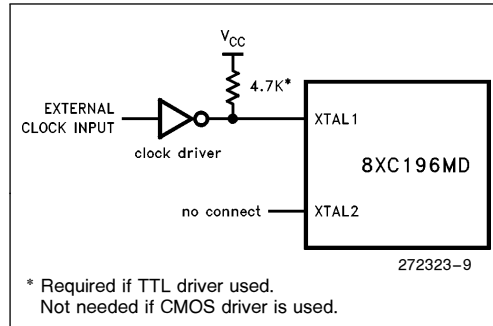

EXTERNAL CLOCK DRIVE WAVEFORMS

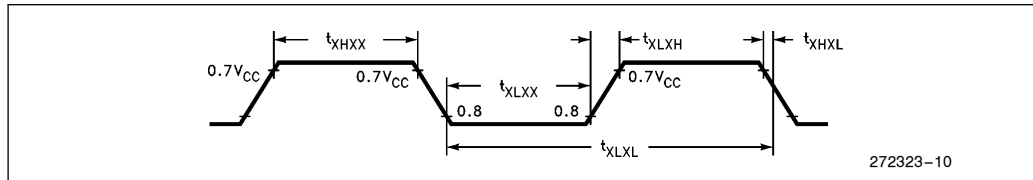

An external oscillator may encounter as much as a 100 pF load at XTAL1 when it starts-up. This is due to interaction between the amplifier and its feedback capacitance. Once the external signal meets the V_{IL} and V_{IH} specifications the capacitance will not exceed 20 pF.

AC TESTING INPUT, OUTPUT WAVEFORMS

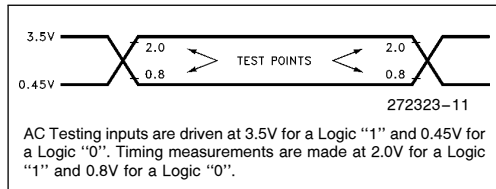

FLOAT WAVEFORMS

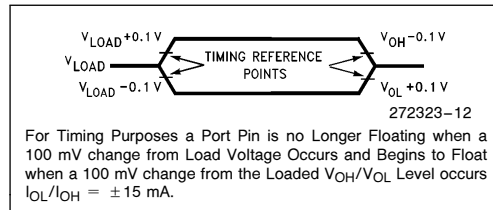

A TO D CHARACTERISTICS

The sample and conversion time of the A/D converter in the 8-bit or 10-bit modes is programmed by loading a byte into the AD__TIME Special Function Register. This allows optimizing the A/D operation for specific applications. The AD__TIME register is functional for all possible values, but the accuracy of the A/D converter is only guaranteed for the times specified in the operating conditions table.

The value loaded into AD__TIME bits 5, 6, 7 determines the sample time, T_{SAM} , and is calculated using the following formula:

$$SAM = \frac{(T_{SAM} \times F_{OSC}) - 2}{8}$$

T_{SAM} = Sample time, μ s
 F_{OSC} = Processor frequency, MHz
 SAM = Value loaded into AD__TIME bits 5, 6, 7

SAM must be in the range 1 through 7.

The value loaded into AD__TIME bits 0–5 determines the conversion time, T_{CONV} , and is calculated using the following formula:

$$CONV = \frac{(T_{CONV} \times F_{OSC}) - 3}{2B} - 1$$

T_{CONV} = Conversion time, μ s
 F_{OSC} = Processor frequency, MHz
 B = 8 for 8-bit conversion
 B = 10 for 10-bit conversion
 CONV = Value loaded into AD__TIME bits 0–5

CONV must be in the range 2 through 31.

The converter is ratiometric, so absolute accuracy is dependent on the accuracy and stability of V_{REF} . V_{REF} must be close to V_{CC} since it supplies both the resistor ladder and the analog portion of the converter and input port pins. There is also an AD__TEST SFR that allows for conversion on ANGND and V_{REF} as well as adjusting the zero offset. The absolute error listed is WITHOUT doing any adjustments.

A/D CONVERTER SPECIFICATION

The specifications given assume adherence to the operating conditions section of this data sheet. Testing is performed with $V_{REF} = 5.12V$ and 16.0 MHz operating frequency. After a conversion is started, the device is placed in the IDLE mode until the conversion is complete.

10-BIT MODE A/D OPERATING CONDITIONS

Symbol	Description	Min	Max	Units
T_A	Ambient Temperature	-40	+85	°C
V_{CC}	Digital Supply Voltage	4.50	5.50	V
V_{REF}	Analog Supply Voltage	4.00	5.50	V(1)
T_{SAM}	Sample Time	1.0		μs (2)
T_{CONV}	Conversion Time	10.0	20.0	μs (2)
F_{OSC}	Oscillator Frequency	8.0	16.0	MHz

NOTES:

ANGND and V_{SS} should nominally be at the same potential.

- V_{REF} must be within 0.5V of V_{CC} .
- The value of AD_TIME is selected to meet these specifications.

10-BIT MODE A/D CHARACTERISTICS (Over Specified Operating Conditions)

Parameter	Typical(1)	Min	Max	Units*
Resolution		1024 10	1024 10	Levels Bits
Absolute Error		0	± 4	LSBs
Full Scale Error	0.25 ± 0.5			LSBs
Zero Offset Error	0.25 ± 0.5			LSBs
Non-Linearity	1.0 ± 2.0		± 4	LSBs
Differential Non-Linearity		> -1	+2	LSBs
Channel-to-Channel Matching	± 0.1	0	± 1.0	LSBs
Repeatability	± 0.25	0		LSBs
Temperature Coefficients:				
Offset	0.009			LSB/C
Full Scale	0.009			LSB/C
Differential Non-Linearity	0.009			LSB/C
Off Isolation		-60		dB(2, 3)
Feedthrough	-60			dB(2)
V_{CC} Power Supply Rejection	-60			dB(2)
Input Series Resistance		750	2K	Ω (4)
Voltage on Analog Input Pin		ANGND - 0.5	$V_{REF} + 0.5$	V(5, 6)
Sampling Capacitor	3			pF
DC Input Leakage	± 1	0	± 3.0	μA

NOTES:

*An "LSB", as used here has a value of approximately 5 mV. (See Embedded Microcontrollers and Processors Handbook for A/D glossary of terms).

- These values are expected for most parts at 25°C but are not tested or guaranteed.
- DC to 100 KHz.
- Multiplexer Break-Before-Make is guaranteed.
- Resistance from device pin, through internal MUX, to sample capacitor.
- These values may be exceeded if the pin current is limited to ± 2 mA.
- Applying voltages beyond these specifications will degrade the accuracy of other channels being converted.
- All conversions performed with processor in IDLE mode.

8-BIT MODE A/D OPERATING CONDITIONS

Symbol	Description	Min	Max	Units
T _A	Ambient Temperature	-40	+85	°C
V _{CC}	Digital Supply Voltage	4.50	5.50	V
V _{REF}	Analog Supply Voltage	4.00	5.50	V(1)
T _{SAM}	Sample Time	1.0		μs(2)
T _{CONV}	Conversion Time	7.0	20.0	μs(2)
F _{OSC}	Oscillator Frequency	8.0	16.0	MHz

NOTES:

 ANGND and V_{SS} should nominally be at the same potential.

 1. V_{REF} must be within 0.5V of V_{CC}.

2. The value of AD_TIME is selected to meet these specifications.

8-BIT MODE A/D CHARACTERISTICS (Over the Above Operating Conditions)

Parameter	Typical(1)	Min	Max	Units*
Resolution		256 8	256 8	Level Bits
Absolute Error		0	±1	LSBs
Full Scale Error	±0.5			LSBs
Zero Offset Error	±0.5			LSBs
Non-Linearity		0	±1	LSBs
Differential Non-Linearity		> -1	+1	LSBs
Channel-to-Channel Matching		0	±1.0	LSBs
Repeatability	±0.25			LSBs
Temperature Coefficients:				
Offset	0.003			LSB/C
Full Scale	0.003			LSB/C
Differential Non-Linearity	0.003			LSB/C
Off Isolation		-60		dB(2, 3)
Feedthrough	-60			dB(2)
V _{CC} Power Supply Rejection	-60			dB(2)
Input Series Resistance		750	2K	Ω(4)
Voltage on Analog Input Pin		V _{SS} - 0.5	V _{REF} + 0.5	V(5, 6)
Sampling Capacitor	3			pF
DC Input Leakage	±1	0	±3.0	μA

NOTES:

*An "LSB" as used here, has a value of approximately 20 mV. (See Embedded Microcontrollers and Processors Handbook for A/D glossary of terms).

1. These values are expected for most parts at 25°C but are not tested or guaranteed.

2. DC to 100 KHz.

3. Multiplexer Break-Before-Make is guaranteed.

4. Resistance from device pin, through internal MUX, to sample capacitor.

5. These values may be exceeded if the pin current is limited to ±2 mA.

6. Applying voltages beyond these specifications will degrade the accuracy of other channels being converted.

7. All conversions performed with processor in IDLE mode.

EPROM SPECIFICATIONS

OPERATING CONDITIONS DURING PROGRAMMING

Symbol	Description	Min	Max	Units
T _A	Ambient Temperature during Programming	20	30	°C
V _{CC}	Supply Voltage during Programming	4.5	5.5	V(1)
V _{REF}	Reference Supply Voltage during Programming	4.5	5.5	V(1)
V _{PP}	Programming Voltage	12.25	12.75	V(2)
V _{EA}	EA Pin Voltage	12.25	12.75	V(2)
F _{OSC}	Oscillator Frequency during Auto and Slave Mode Programming	6.0	8.0	MHz
T _{OSC}	Oscillator Frequency during Run-Time Programming	6.0	12.0	MHz

NOTES:

1. V_{CC} and V_{REF} should nominally be at the same voltage during programming.
2. V_{PP} and V_{EA} must never exceed the maximum specification, or the device may be damaged.
3. V_{SS} and ANGND should nominally be at the same potential (0V).
4. Load capacitance during Auto and Slave Mode programming = 150 pF.

AC EPROM PROGRAMMING CHARACTERISTICS (SLAVE MODE)

Symbol	Parameter	Min	Max	Units
T _{SHLL}	Reset High to First $\overline{\text{PALE}}$ Low	1100		T _{OSC}
T _{LLLH}	$\overline{\text{PALE}}$ Pulse Width	50		T _{OSC}
T _{AVLL}	Address Setup Time	0		T _{OSC}
T _{LLAX}	Address Hold Time	100		T _{OSC}
T _{PLDV}	$\overline{\text{PROG}}$ Low to Word Dump Valid		50	T _{OSC}
T _{PHDX}	Word Dump Data Hold		50	T _{OSC}
T _{DVPL}	Data Setup Time	0		T _{OSC}
T _{PLDX}	Data Hold Time	400		T _{OSC}
T _{PLPH} ⁽¹⁾	$\overline{\text{PROG}}$ Pulse Width	50		T _{OSC}
T _{PHLL}	$\overline{\text{PROG}}$ High to Next $\overline{\text{PALE}}$ Low	220		T _{OSC}
T _{LHPL}	$\overline{\text{PALE}}$ High to $\overline{\text{PROG}}$ Low	220		T _{OSC}
T _{PHPL}	$\overline{\text{PROG}}$ High to Next $\overline{\text{PROG}}$ Low	220		T _{OSC}
T _{PHIL}	PROG High to AINC Low	0		T _{OSC}
T _{ILIH}	$\overline{\text{AINC}}$ Pulse Width	240		T _{OSC}
T _{ILVH}	PVER Hold after $\overline{\text{AINC}}$ Low	50		T _{OSC}
T _{ILPL}	$\overline{\text{AINC}}$ Low to $\overline{\text{PROG}}$ Low	170		T _{OSC}
T _{PHVL}	$\overline{\text{PROG}}$ High to PVER Valid		220	T _{OSC}

NOTE:

1. This specification is for the Word Dump Mode. For programming pulses, use the Modified Quick Pulse Algorithm.

DC EPROM PROGRAMMING CHARACTERISTICS

Symbol	Parameter	Min	Max	Units
I_{PP}	V_{PP} Supply Current (When Programming)		100	mA

NOTE:

Do not apply V_{PP} until V_{CC} is stable and within specifications and the oscillator/clock has stabilized or the device may be damaged.

SLAVE PROGRAMMING MODE DATA PROGRAM MODE WITH SINGLE PROGRAM PULSE

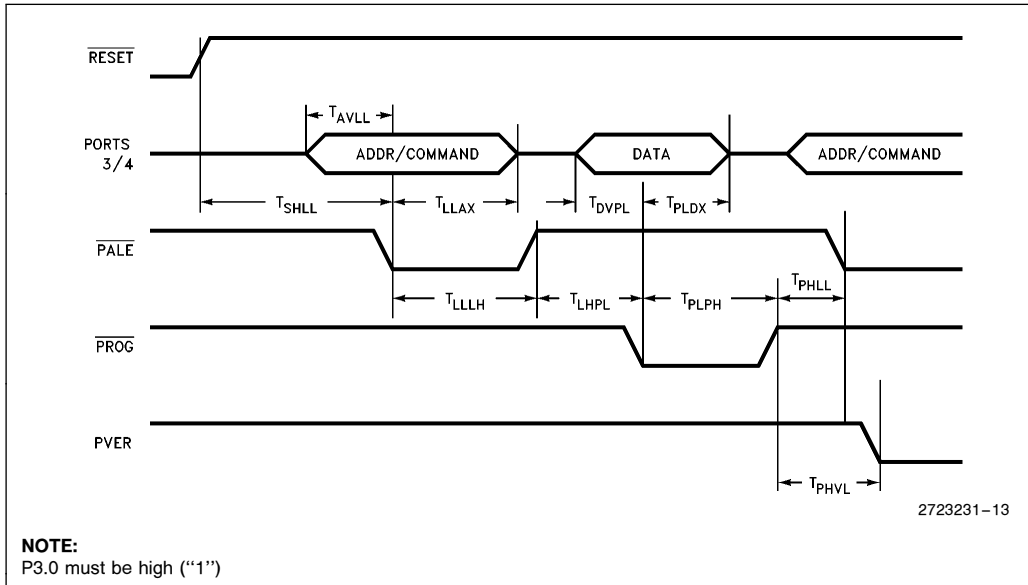

SLAVE PROGRAMMING MODE IN WORD DUMP WITH AUTO INCREMENT

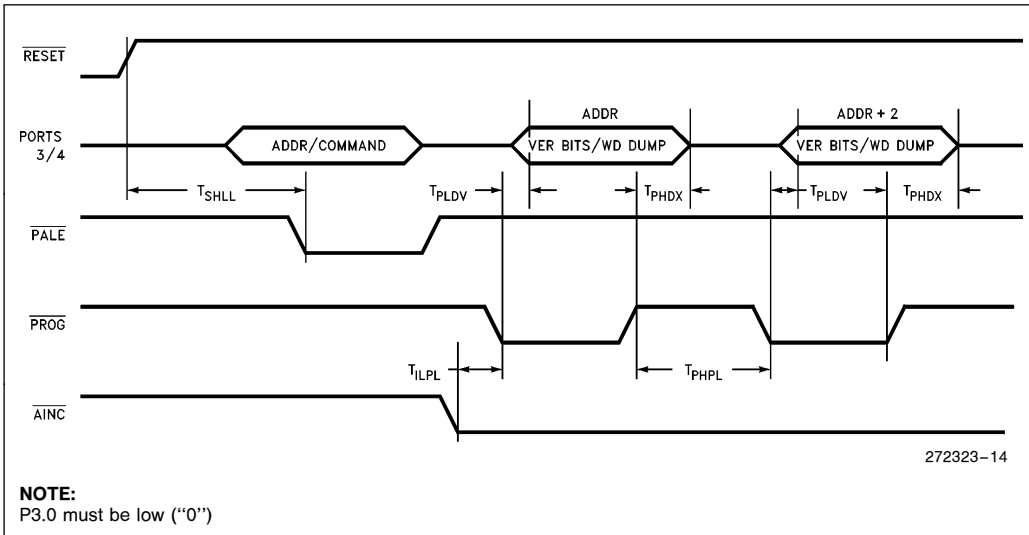

SLAVE PROGRAMMING MODE TIMING IN DATA PROGRAM WITH REPEATED PROG PULSE AND AUTO INCREMENT

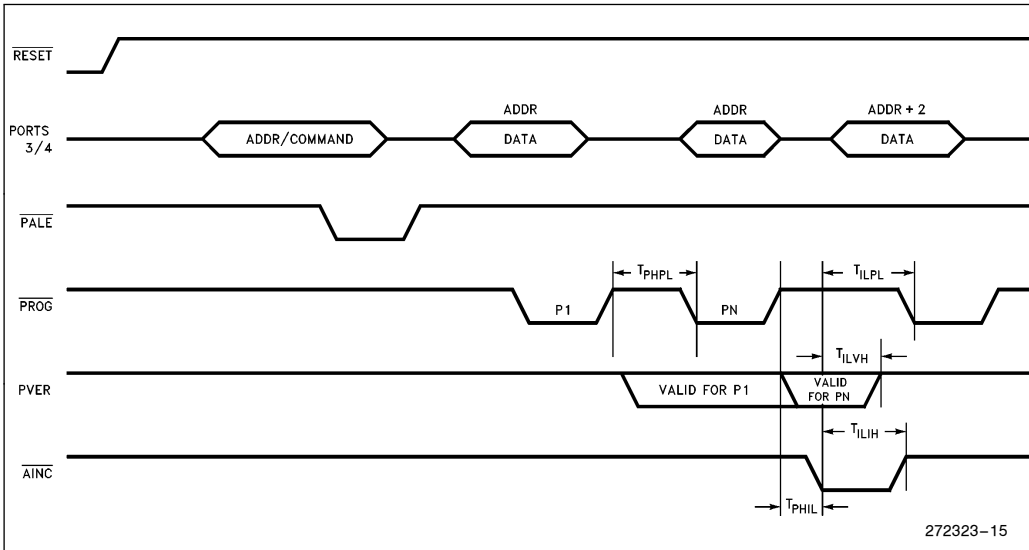



87C196MD DESIGN CONSIDERATIONS

When an indirect shift during divide occurs the upper 3 bits of the shift count are not masked completely. If the shift count register has the value $32 * n$ where $n \in \{1, 3, 5, 7\}$, the operand will be shifted 32 times. This should have resulted in no shift taking place.

8XC196MC to 8XC196MD Design Considerations

8XC196MC and 8XC196MD are pin compatible. However, there were several pins that were not connected (NC) on the 8XC196MC that are I/O pins on

the 8XC196MD. Port 7 is a bidirectional port added to the 8XC196MD. Port 1 has one additional analog or digital input that was connected to V_{SS} on the 8XC196MC. Port 1 also has two additional digital inputs. See 8XC196MC and 8XC196MD Differences Section of this data sheet.

DATA SHEET REVISION HISTORY

Document 272323-003 was updated due to changes required for the lead free initiative. To address the fact that many of the package prefix variables have changed, all package prefix variables in the document are now indicated with an "x".