

# TOF-F5451BG-B

## Four Digit Display LED

Part Number	Chip		Face Color	Segment Color
	Material	Source Color		
TOF-F5451BG-B	GaP	Green	Black	White

### Features

- (0.55") 14.10mm digit height
- Common anode
- I.C. compatible
- Low power consumption
- RoHS compliant

### Applications

- Audio equipment
- Instrument panels
- Digital read out display

### Package Dimensions & Internal Circuit Diagram

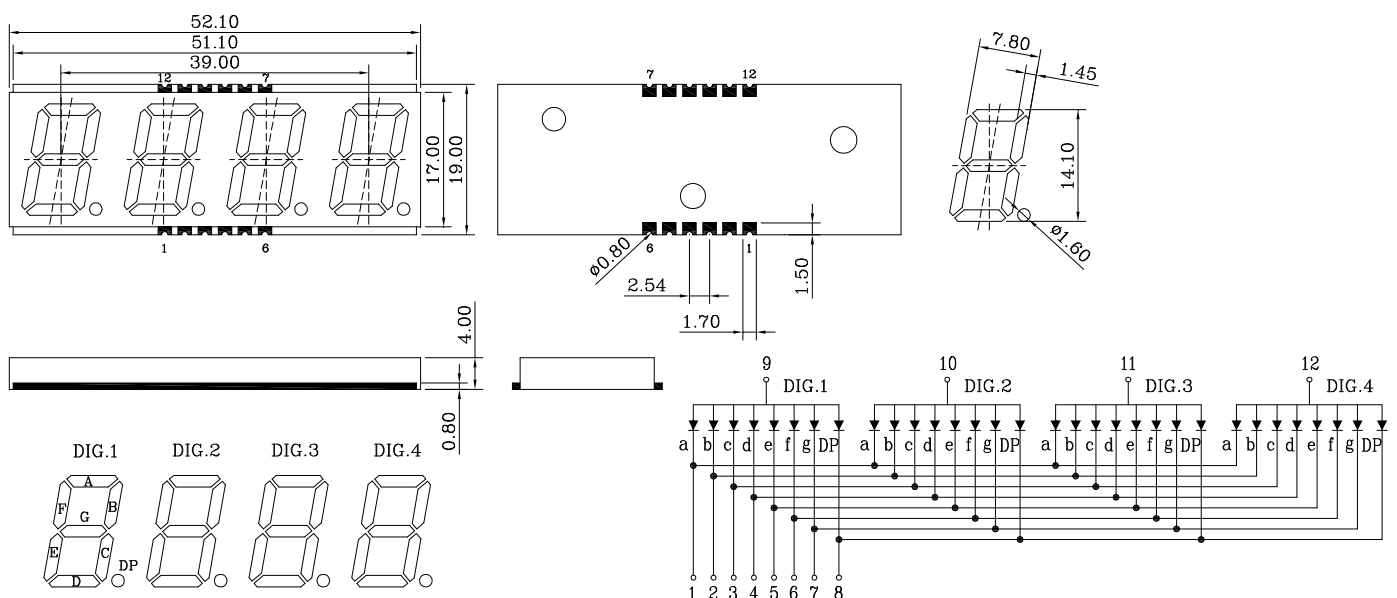

#### Notes:

1. All dimensions are in millimeters, tolerance:  $\pm 0.25$  ; Angle:  $\pm 0.1^\circ$  unless otherwise noted.
2. Specifications are subject to change without notice.

## Absolute Maximum Rating @ Ta=25°C

Parameter	Maximum Rating	Unit
Peak Forward Current (1/10 Duty Cycle, 0.1ms Pulse Width)	80	mA
Power Dissipation	75	mW
Continuous Forward Current	20	mA
Recommend Operating Current	12	mA
Reverse Voltage	5	V
Operating Temperature Range	-25°C to +85°C	
Storage Temperature Range	-30°C to +85°C	
Lead-Free Solder Temperature	250°C for 10 Sec	

## Electrical / Optical Characteristic @ Ta=25°C

Parameter	Symbol	Min.	Typ.	Max.	Unit	Test Condition	Grade
Dominant Wavelength	$\lambda_d$		572		nm	$I_F=20mA$	
Spectral Line Half-Width	$\Delta\lambda$		30		nm	$I_F=20mA$	
Forward Voltage	$V_F$	1.9	2.2	2.5	V	$I_F=20mA$	
Reverse Current	$I_R$			100	$\mu A$	$V_R=5V$	
Luminous Intensity Matching Rate	lv-m			1.5:1		$I_F=20mA$	

The DISPLAYS should be kept at 30°C or less and 60%RH or less. The DISPLAYS should be used within one year

[www.oasistek.com.tw](http://www.oasistek.com.tw)

Contact us : [service@oasistek.com.tw](mailto:service@oasistek.com.tw)

Catalogue : <http://goo.gl/6rcsV6>