



TP-M115
TP-M105

YUB YUB3

YB YBB YHB

YJB YLB

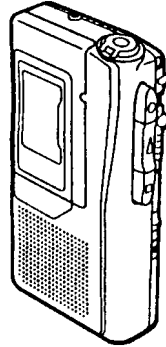

SERVICE MANUAL

MICROCASSETTE RECORDER

BASIC TAPE MECHANISM : M-187

aiwa

S/M Code No. 09-003-341-9N1



SPECIFICATIONS

Track system:	Micro cassette, 2 tracks 1 channel, monaural						
Usable tapes:	MICROCASSETTE™ (Normal position type)						
Frequency response:	250 - 5,000 Hz (2.4 cm/sec) EIAJ						
Tape speed:	2.4 cm/sec or 1.2 cm/sec switchable						
Microphone:	Electret condenser microphone (monaural)						
Maximum output:	110 mW (EIAJ/DC)						
Output jack:	EARPHONE jack (monaural mini-jack) (1)						
Other jack:	DC 3 V jack						
Speaker:	Diameter 36 mm, 4 ohms						
Recording system:	DC bias						
Erasing system:	Magnet erasure						
Power sources:	DC 3 V using two size AA (R6) dry cell batteries AC house current using the AC adaptor Aiwa AC-302						
Battery life:	<table border="1" style="width: 100%; border-collapse: collapse; text-align: center;"> <thead> <tr> <th style="width: 60%;">Battery</th> <th>Battry life EIAJ Recording</th> </tr> </thead> <tbody> <tr> <td>Manganese(R6P) batteries</td> <td>Approx. 7 hrs.</td> </tr> <tr> <td>Alkaline(LR6) batteries</td> <td>Approx. 24 hrs</td> </tr> </tbody> </table>	Battery	Battry life EIAJ Recording	Manganese(R6P) batteries	Approx. 7 hrs.	Alkaline(LR6) batteries	Approx. 24 hrs
Battery	Battry life EIAJ Recording						
Manganese(R6P) batteries	Approx. 7 hrs.						
Alkaline(LR6) batteries	Approx. 24 hrs						
Dimensions:	63.8 (W) x 121(H) x 25.7 (D) mm (2 ⁵ / ₈ x 4 ⁷ / ₆ x 1 ¹ / ₁₆ in)						
Weight:	Approx. 116 g (4.1 oz.) (excluding batteries)						

• Design and specifications are subject to change without notice.

ACCESSORIES LIST

DESCRIPTIONで判断できない物は "REFERENCE NAME LIST" を参照してください。
If can't understand for Description please kindly refer to "REFERENCE NAME LIST".

REF. NO	PART NO.	KANRI NO.	DESCRIPTION
1	8A-HX8-901-010	IB, YU(3L)C<115U,115U3>	
1	8A-HX8-902-010	IB, YHJ(ECC)C<105YHB,105YJB>	
1	8A-HX8-904-010	IB, YL(3L)C<105YLB>	
1	8A-HX8-905-010	IB, Y(EGF)C<105YB>	
1	8A-HX8-906-010	IB, Y(SID)C<105YB>	
1	8A-HX8-907-010	IB, Y(PHNCZ)C<105YB>	

ELECTRICAL MAIN PARTS LIST

DESCRIPTIONで判断できない物は "REFERENCE NAME LIST" を参照してください。
 If can't understand for Description please kindly refer to "REFERENCE NAME LIST".

REF. NO	PART NO.	KANRI NO.	DESCRIPTION	REF. NO	PART NO.	KANRI NO.	DESCRIPTION
IC				C27	87-010-186-080		CAP,CHIP 4700P
	85-TM5-604-010	IC,LA4165M		J1	85-TM5-605-010		JACK,HSJ1456
				J2	87-A60-849-010		JACK,DC DIA 2.75 BLK
				LED2	8Z-HX5-601-010		LED,KM2520A01SRC001 RED
				S1	8Z-HX5-602-010		SW,PUSH PS42D07
MAIN C.B				S2	87-031-816-010		SLIDE SWITCH<115U,115U3>
C1	87-010-193-080		CHIP CAPACITOR,0.033	S3	87-031-816-010		SLIDE SWITCH
C2	87-010-186-080		CAP,CHIP 4700P	S4	87-036-343-010		SW,SL 2-2-2
C3	87-010-185-080		C-CAP,S 3900P-50 B	S5	85-TM5-608-010		SW,LEAF LSA-1114P
C4	87-010-082-010		CAPACITOR, 220MF 4V/87-0	S8	87-A90-826-010		SW,LEAF LSA-1114P
C5	87-010-072-010		CAP 2.2-50V	SFR1	85-TM5-615-010		SFR,5K V FRB-062
C6	87-010-184-080		CHIP CAPACITOR 3300P(K)	SFR3	87-A91-282-080		C-SFR,2.0K H RVG3S08
C7	87-010-198-080		CAP, CHIP 0.022	VR1	85-TM5-609-010		VR,RTRY 10KAX2 V
C8	87-010-186-080		CAP,CHIP 4700P				
C9	87-010-504-080		CAP, CHIP TANTALUM 0.47-25				
C10	87-010-075-010		CAP,10U-16V H5				
C11	87-010-490-010		CAP,E 0.1-50 GAS<115U,115U3>				
C12	87-A10-952-080		C-CAP,TN 22-4 M A MCM<115U,115U3>				
C13	87-010-082-010		CAPACITOR, 220MF 4V/87-0				
C14	87-010-082-010		CAPACITOR, 220MF 4V/87-0				
C15	87-010-082-010		CAPACITOR, 220MF 4V/87-0				
C16	87-010-178-080		CHIP CAP 1000P				
C17	87-010-505-080		CA, CHIP TANTALUM 1-16				
C18	87-010-504-080		CAP, CHIP TANTALUM 0.47-25				
C22	87-010-746-080		CAP, TANTAL 10-4				
C23	87-010-494-010		E CAP 1-50				

○チップ抵抗部品コード／CHIP RESISTOR PART CODE

チップ抵抗部品コードの成り立ち

Chip Resistor Part Coding

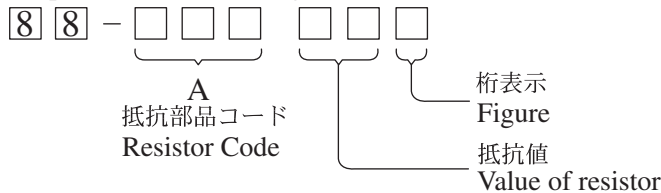

チップ抵抗 Chip resistor

容量 Wattage	種類 Type	許容誤差 Tolerance	記号 Symbol	寸法/Dimensions (mm)			抵抗コード : A Resistor Code : A	
				外形/Form	LW	t		
1/16W	1005	± 5%	CJ		1.0	0.5	0.35	104
1/16W	1608	± 5%	CJ		1.6	0.8	0.45	108
1/10W	2125	± 5%	CJ		2	1.25	0.45	118
1/8W	3216	± 5%	CJ		3.2	1.6	0.55	128

SCHEMATIC DIAGRAM

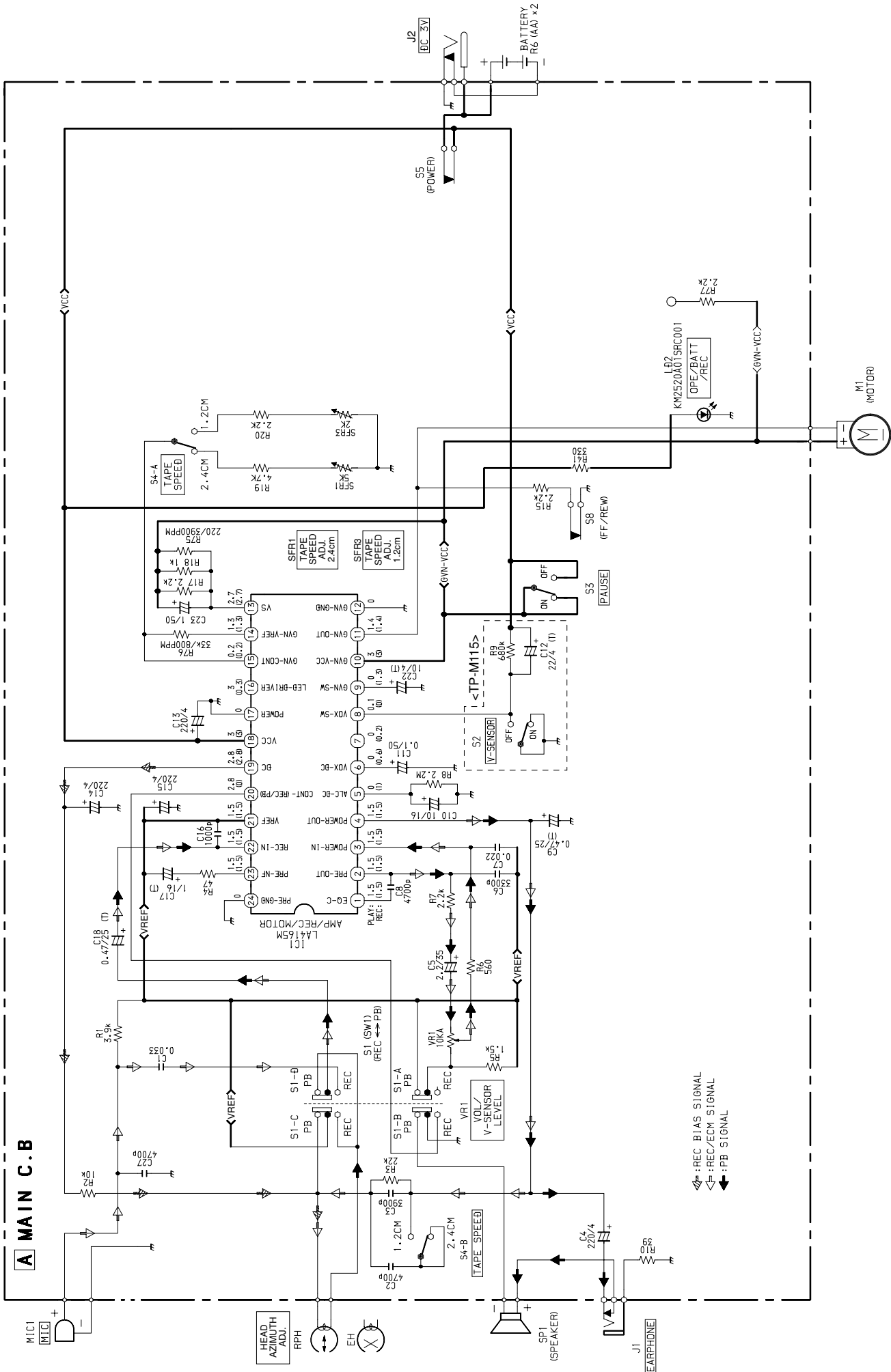

ADJUSTMENT

A MAIN C.B (BOTTOM VIEW)

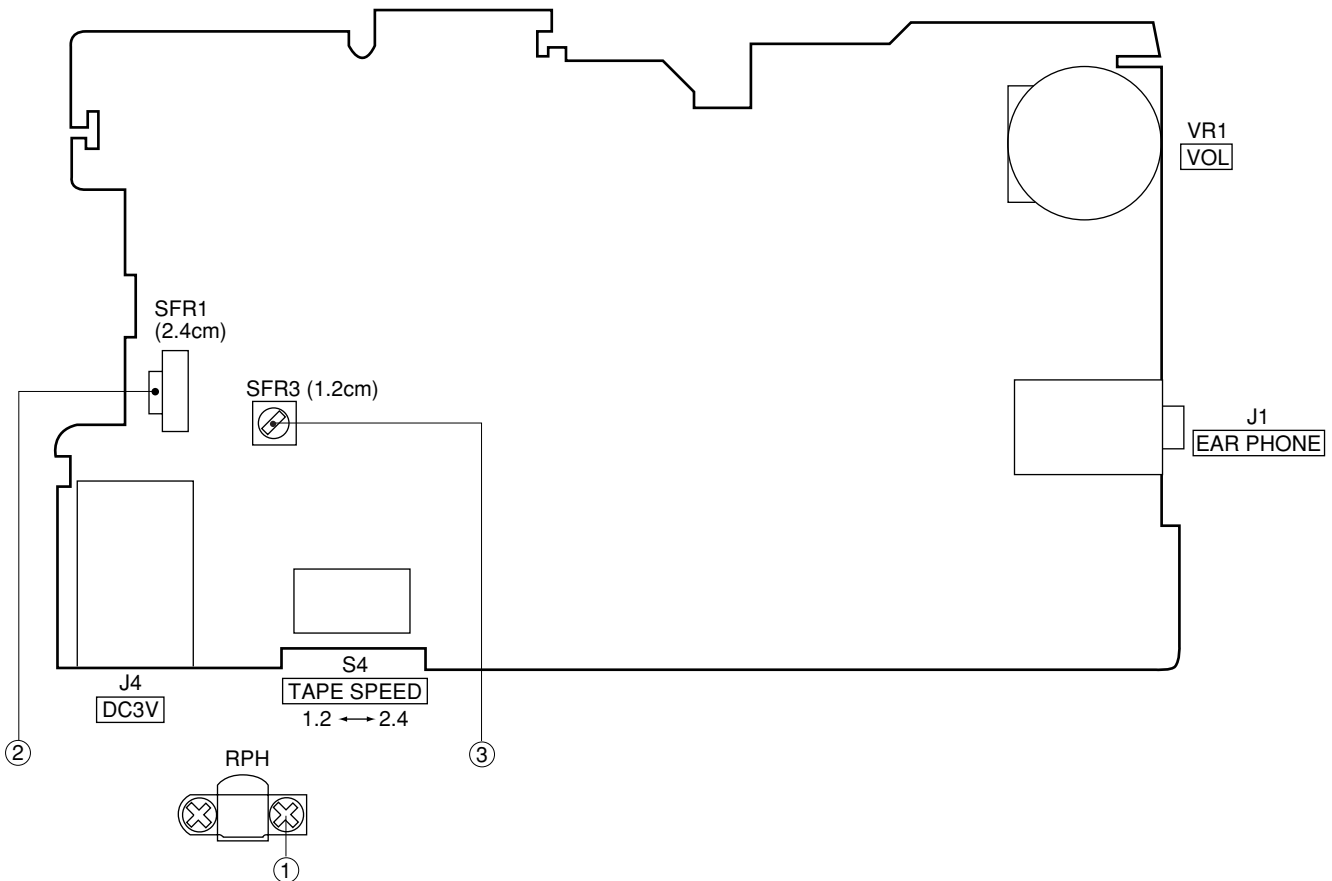

1. Head Azimuth Adjustment

- Setting:
- Test tape: TTS-930
 - Tape speed: 2.4 cm
 - Adjustment point: Head Azimuth Adjustment screw

Method: Playback the 5 kHz signal of the test tape (TTS-930) and adjust screw so that the output becomes maximum.

2. Tape Speed Adjustment (2.4cm)

- Setting:
- Test tape: TTS-900
 - Volume: MAX
 - Adjustment point: SFR1

Method: Playback the test tape (TTS-900) and adjust SFR1 so that the tape speed is become $3000 \pm 10\text{Hz}$.

3. Tape Speed Adjustment (1.2cm)

- Setting:
- Test tape: TTS-910
 - Volume: MAX
 - Adjustment point: SFR3

Method: Playback the test tape (TTS-910) and adjust SFR3 so that the tape speed is become $3000 \pm 90\text{Hz}$.

PRACTICAL SERVICE FIGURE

Tape speed:	$3000 \text{ Hz} \pm 90 \text{ Hz}$
Wow & flutter:	Less than 0.65% (RMS) (2.4cm) Less than 0.65% (RMS) (1.2cm)
Take-up torque:	4 ~ 12 g-cm
F.F torque:	30 ~ 150 g-cm
Rew torque:	25 ~ 60 g-cm
Back tension:	Less than 1.3 g-cm
S/N ratio:	More than 50 dB (DC. PB) More than 26 dB (DC. R/PB)
Noise level:	Less than 1.7 mV (DC. Vol Max. PB) Less than 18 mV (DC. Vol Max. R/PB)
Erasing ratio:	More than 40 dB (1 kHz)
Test tape:	TTS-900 (Wow & flutter/Tape speed – 2.4 cm) TTS-910 (Wow & flutter/Tape speed – 1.2 cm) TTS-920 (Distortion/Output) TTS-930 (Azimuth) TTS-940 (REC/PB)

IC BLOCK DIAGRAM

IC, LA4165M

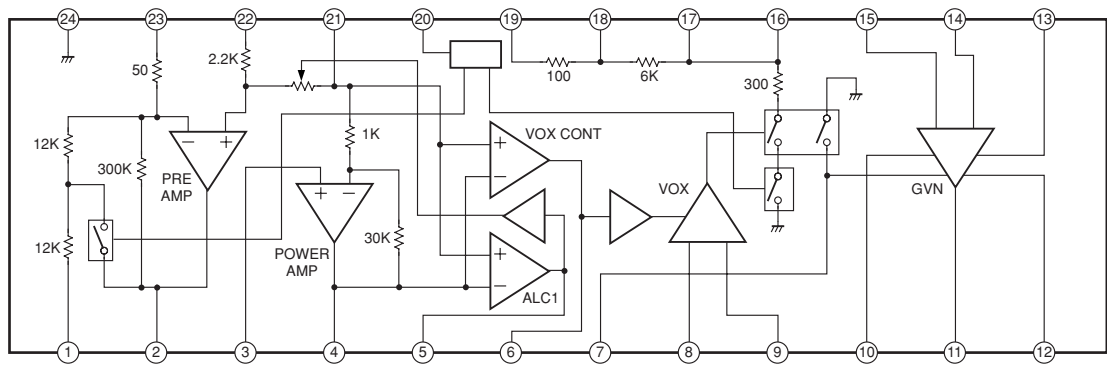

MECHANICAL EXPLODED VIEW 1/1

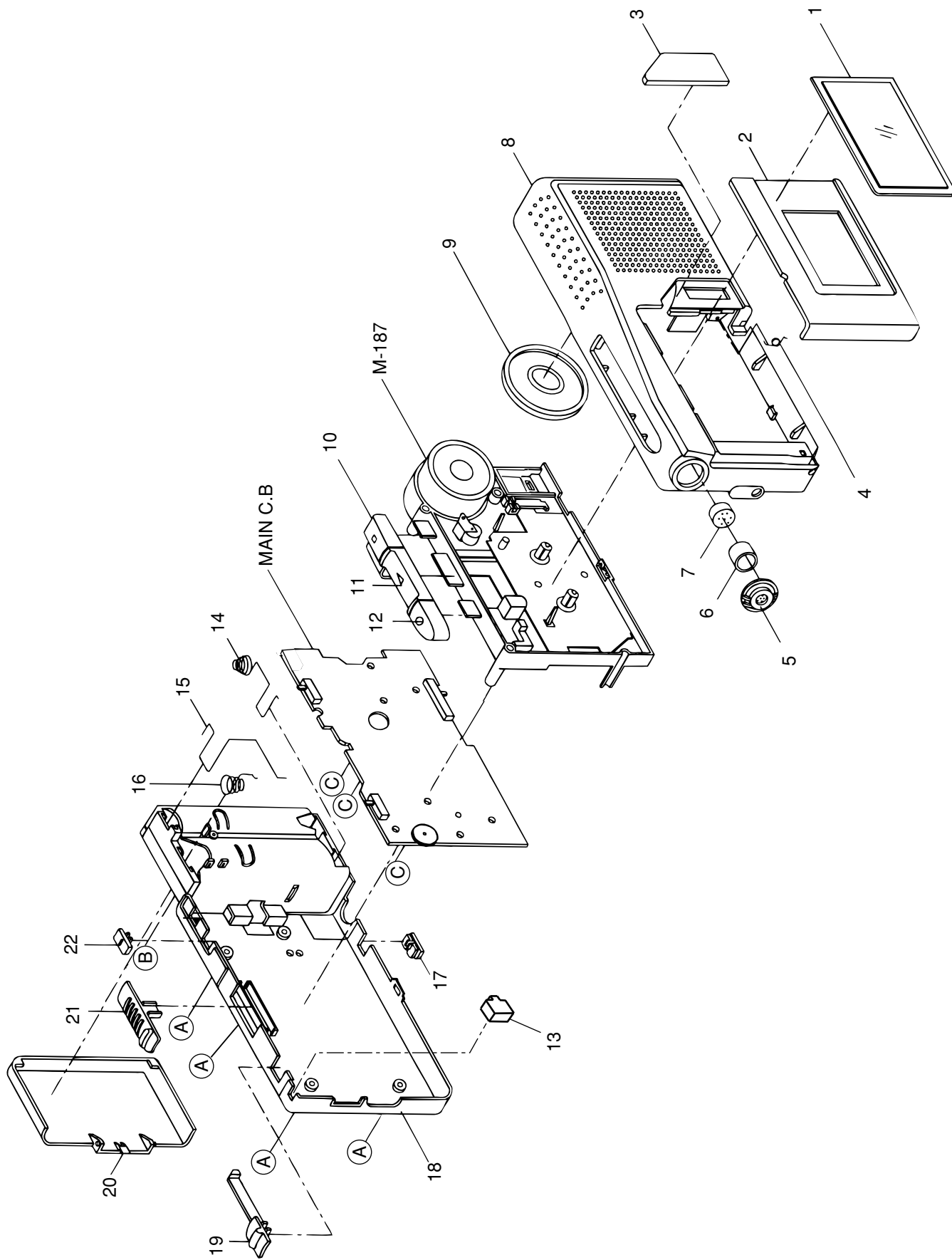

MECHANICAL MAIN PARTS LIST 1/1

DESCRIPTIONで判断できない物は "REFERENCE NAME LIST" を参照してください。
 If can't understand for Description please kindly refer to "REFERENCE NAME LIST".

REF. NO	PART NO.	KANRI NO.	DESCRIPTION
1	8A-HX8-009-010		WINDOW,CASS M105<EXCEPT 115U,115U3>
1	8A-HX8-003-010		WINDOW,CASS M115 YU<115U,115U3>
2	8A-HX8-008-010		LID,CASS B M115/M105
3	8A-HX8-010-010		LENS,COUNTER M105 Y<EXCEPT 115U,115U3>
3	8A-HX8-004-010		LENS,COUNTER M115 YU<115U,115U3>
4	8Z-HX5-201-010		SPR,CASS
5	8A-HX8-005-010		COVER, MIC M115/M105
6	S6-HX5-210-000		CUSHION MIC
7	84-TM1-639-010		ECM,KUC3523
8	8A-HX8-006-010		CABI,FRONT B M105 Y<EXCEPT 115U,115U3>
8	8A-HX8-001-010		CABI,FRONT B M115 YU<115U,115U3>
9	S1-440-004-210		SPKR,1.4' (36mm) 4 OHM 0.4W
10	8Z-HX7-015-010		BTN,CASS STOP YU
11	8Z-HX7-014-010		BTN,CASS PLAY YU
12	8Z-HX7-013-010		BTN,CASS REC YU
13	8Z-HX5-020-010		LENS,LED
14	85-TM5-203-010		SPR,BAT(+/-)
15	85-TM5-204-010		SPR,BAT(+)
16	85-TM5-205-010		SPR,BAT(-)
17	8Z-HX7-021-010		KNOB,SL 1.2/2.4 YU
18	8A-HX8-007-010		CABI,REAR B M105 Y<EXCEPT 115U,115U3>
18	8A-HX8-002-010		CABI,REAR B M115 YU<115U,115U3>
19	8Z-HX7-020-010		KNOB,SL PAUSE YU
20	8Z-HX7-007-010		LID,BATT YU
21	8Z-HX7-019-010		KNOB,SL FF/REW YU
22	8Z-HX7-035-010		KNOB,SL V-SENSOR YU<115U,115U3>
A	87-261-043-410		V+2-20
B	87-261-553-310		V+2-6 BLK
C	87-261-533-310		SCREW V+1.7-6 BLK

COLOR NAME TABLE

Basic color symbol	Color	Basic color symbol	Color	Basic color symbol	Color
B	Black	C	Cream	D	Orange
G	Green	H	Gray	L	Blue
LT	Transparent Blue	N	Gold	P	Pink
R	Red	S	Silver	ST	Titan Silver
T	Brown	V	Violet	W	White
WT	Transparent White	Y	Yellow	YT	Transparent Yellow
LM	Metallic Blue	LL	Light Blue	GT	Transparent Green
LD	Dark Blue	DT	Transparent Orange		

MECHANISM EXPLODED VIEW 1/1

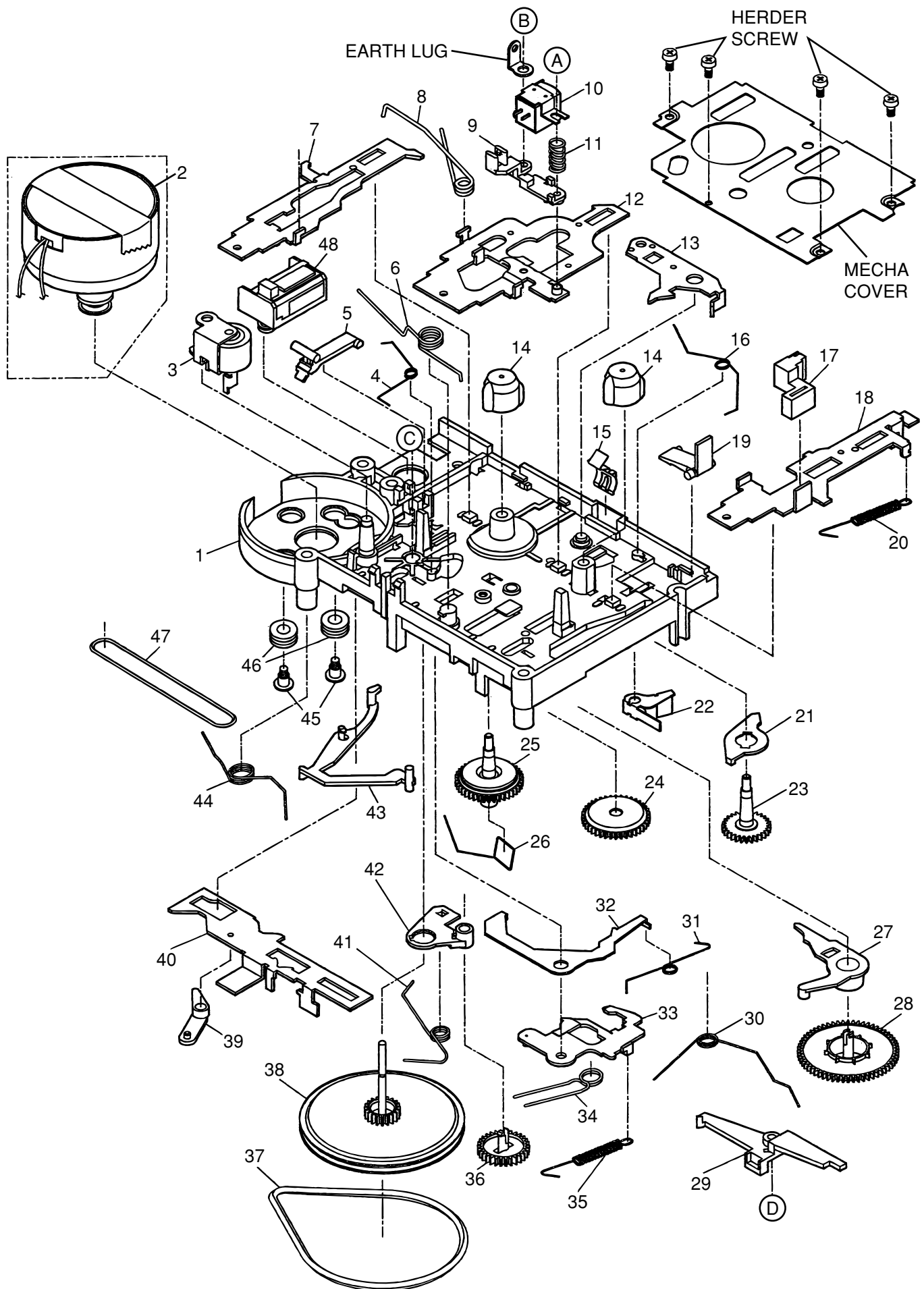

MECHANISM MAIN PARTS LIST 1/1

DESCRIPTIONで判断できない物は "REFERENCE NAME LIST" を参照してください。
 If can't understand for Description please kindly refer to "REFERENCE NAME LIST".

REF. NO	PART NO.	KANRI NO.	DESCRIPTION	REF. NO	PART NO.	KANRI NO.	DESCRIPTION
1	S1-800-01K-000		CHASSIS ASSY	27	S1-800-780-000		REW ARM
2	SR-F30-0C1-427		MOTOR ASSY	28	S1-800-270-000		REW CEAR
3	S1-800-13K-000		PINCH ARM ASSY	29	S1-800-390-000		SHUT OFF ARM
4	S1-800-100-000		EARTH SP	30	S1-800-800-000		THRUST SP
6	S1-800-080-000		HEAD BASE SP	31	S1-800-440-000		REC LOCK SP
7	S1-800-060-000		STOP LAVER	32	S1-800-430-000		REC LOCK PLATE
8	S1-800-120-000		PINCH ARM SP	33	S1-800-170-000		SW ARM
9	S1-800-150-000		AZ SPACER	34	S1-800-220-000		FR LEVER SP
10	ST-MC2-13E-000		R/P HEAD	35	S1-800-180-000		SW ARM SP
11	S1-800-160-000		AZIMUTH SP	36	S1-800-260-000		CENTER GEAR
12	S8-000-700-000		HEAD BASE	37	SV-400-000-000		MAIN BELT
13	S1-800-040-000		LOCK PLATE	38	S1-800-35K-000		FW CP ASSY
14	S1-800-290-000		REEL CAP	39	S1-800-740-000		RESET ARM(A)
15	S1-800-730-000		CST HOLDER SP	40	S1-800-210-000		FR LEVER
16	S1-800-050-000		LOCK PLATE SP	41	S1-800-250-000		CENTER ARM SP
17	SE-695-100-000		E HEAD	42	S1-800-240-000		CENTER ARM
18	S1-800-090-000		REC LEVER	45	SM-100-075-000		MOTOR SCREW
19	S1-800-030-000		REC LOCK LEVER	46	S3-741-150-000		RUBBER CUSHION
20	S1-800-760-200		REC LEVER SP	A	S3-PB1-4X6-500		SCREW
21	S1-800-450-000		RESET ARM	B	S3-PB1-4X2-500		SCREW
22	S1-800-720-000		REC SW LEVER	C	S1-0X2-4X0-5LC		L-CUT-W-W
23	S1-800-280-000		REEL (S) GEAR	D	S1-2X3-0X0-188		L-CUT-W-Y
24	S1-800-410-000		SHUT OFF GEAR	E	S2-1X4-X02-LWR		LW(RED)
25	S1-800-30K-000		REEL (T) ASSY				
26	S1-800-510-000		SHUT OFF SP				



サービス技術ニュース	
番号	連絡内容
G- -	
G- -	
G- -	

アイワ株式会社 〒110-8710 東京都台東区池之端1-2-11 ☎03(3827)3111 (代表)
AIWA CO.,LTD. 2-11, IKENOHATA 1-CHOME, TAITO-KU, TOKYO 110-8710, JAPAN TEL:03 (3827) 3111