

REMARK

- 1. Glass Thk: 1.1mm
- 2. Film Type: Non-Glare
- 3. Total Thk: 1.44±0.15mm (Including Rear Adhesive Tape)
- 4. Linearity: ±1.5% or less
- 5. Transmittance: 80% or more
- 6. Resistance
 - 200 < X < 900 ohm
 - 200 < Y < 900 ohm
- 7. Connector: FPC
- 8. General Tolerance: ±0.3

CIRCUIT DIAGRAM

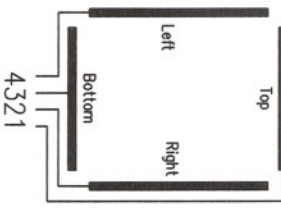

SIGNAL ASSIGNMENT

Pin No	Signal
1	Top
2	Right
3	Bottom
4	Left

Detail 1 "AA" (Scale=4/1)

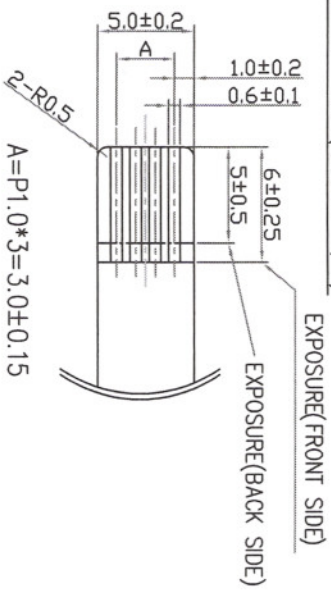

REV/NO	REVISION	DATE	DRAWN	CHECKED	APPROVED
1	Changed Mode Name	08.02.18	H.Y.M		Y.J.H
0	NEW DRAW	06.03.29	H.Y.M, J.H.LEE, W.AHN		

APPROVE	STD.TOL	UNIT	mm	DRAWING NO.	REV.
CHECK		SCALE	NONE		1
DESIGN		DESCRIPTION			SHEET
DRAW		3.8" TOUCH PANEL			1/1