



**DESCRIPTION: 6W 1.5KVDC Isolated Wide Input Voltage DC/DC Converters**

The rated output power of TP06DA converters is 6W, the outline dimensions is "31.75\*20.32\*11.2", 2:1 and 4:1 wide input Voltage range, the voltage range is 9V-18V, 18V-36V, 36V-72V, 9V-36V and 18V-72VDC. The accuracy of the converter can reach  $\pm 1\%$  it can be widely used in telecommunications, railway transportation, instrument and etc.

**FEATURES**

6W output power	2:1 and 4:1 wide input voltage range	Over load protection
31.75mm*20.32mm*11.2mm standard package	Fixed switching frequency	Operating temperature: -40°C to 85°C
Metal shell package	RoHS compliant	1.5KVDC isolation

**SELECTION GUIDE**

Part Number	Input Voltage		Output		Efficiency(Typ) %	Maxmum capacitive load (u F)
	voltage (VDC)		Voltage (VDC)	Current (A)		
	Rated	Range values				
TP06DA05S05	5(2:1)	4.5-9	5	1.2	$\geq 79$	1500
TP06DA05D05	5(2:1)	4.5-9	$\pm 5$	$\pm 0.6$	$\geq 79$	$\pm 850$
TP06DA12S03	12(2:1)	9-18	3.3	1.5	$\geq 77$	2200
TP06DA12S05	12(2:1)	9-18	5	1.2	$\geq 79$	1500
TP06DA12S12	12(2:1)	9-18	12	0.5	$\geq 82$	660
TP06DA12S15	12(2:1)	9-18	15	0.4	$\geq 84$	470
TP06DA12D05	12(2:1)	9-18	$\pm 5$	$\pm 0.6$	$\geq 79$	$\pm 850$
TP06DA12D12	12(2:1)	9-18	$\pm 12$	$\pm 0.25$	$\geq 82$	$\pm 140$
TP06DA12D15	12(2:1)	9-18	$\pm 15$	$\pm 0.2$	$\geq 84$	$\pm 47$
TP06DA24S03	24(2:1)	18-36	3.3	1.5	$\geq 78$	2200
TP06DA24S05	24(2:1)	18-36	5	1.2	$\geq 80$	1500
TP06DA24S12	24(2:1)	18-36	12	0.5	$\geq 84$	660
TP06DA24S15	24(2:1)	18-36	15	0.4	$\geq 86$	470
TP06DA24S24	24(2:1)	18-36	24	0.25	$\geq 83$	470
TP06DA24D05	24(2:1)	18-36	$\pm 5$	$\pm 0.6$	$\geq 81$	$\pm 850$
TP06DA24D12	24(2:1)	18-36	$\pm 12$	$\pm 0.25$	$\geq 84$	$\pm 140$
TP06DA24D15	24(2:1)	18-36	$\pm 15$	$\pm 0.2$	$\geq 86$	$\pm 47$
TP06DA48S03	48(2:1)	36-72	3.3	1.5	$\geq 78$	2200
TP06DA48S05	48(2:1)	36-72	5	1.2	$\geq 80$	1500
TP06DA48S12	48(2:1)	36-72	12	0.5	$\geq 84$	660
TP06DA48S15	48(2:1)	36-72	15	0.4	$\geq 86$	470
TP06DA48D05	48(2:1)	36-72	$\pm 5$	$\pm 0.6$	$\geq 80$	$\pm 850$
TP06DA48D12	48(2:1)	36-72	$\pm 12$	$\pm 0.25$	$\geq 84$	$\pm 140$
TP06DA48D15	48(2:1)	36-72	$\pm 15$	$\pm 0.2$	$\geq 83$	$\pm 47$
TP06DA24S05W	24(4:1)	9-36	5	1.2	$\geq 80$	1500
TP06DA24S12W	24(4:1)	9-36	12	0.5	$\geq 82$	660
TP06DA24S15W	24(4:1)	9-36	15	0.4	$\geq 84$	470
TP06DA24D05W	24(4:1)	9-36	$\pm 5$	$\pm 0.6$	$\geq 80$	$\pm 850$
TP06DA24D12W	24(4:1)	9-36	$\pm 12$	$\pm 0.25$	$\geq 82$	$\pm 140$
TP06DA24D15W	24(4:1)	9-36	$\pm 15$	$\pm 0.2$	$\geq 84$	$\pm 47$
TP06DA48S05W	48(4:1)	18-72	5	1.2	$\geq 77$	1500
TP06DA48S12W	48(4:1)	18-72	12	0.5	$\geq 80$	660
TP06DA48S15W	48(4:1)	18-72	15	0.4	$\geq 84$	470
TP06DA48D05W	48(4:1)	18-72	$\pm 5$	$\pm 0.6$	$\geq 80$	$\pm 850$
TP06DA48D12W	48(4:1)	18-72	$\pm 12$	$\pm 0.25$	$\geq 82$	$\pm 140$
TP06DA48D15W	48(4:1)	18-72	$\pm 15$	$\pm 0.2$	$\geq 79$	$\pm 47$

All specifications typical at TA=25°C, nominal input voltage and rated output current unless otherwise specified.

GENERAL CHARACTERISTICS					
parameter	Test conditions	Min	Typ	Max	Units
Isolation voltage	Input to Output		500	1500	VDC
Isolation resistance	Input to Output	100M			ohm
Seismic	10~55Hz		5		G
MTBF	MIL-HDBK-217F2		5 x 10 <sup>5</sup>		hrs
Over-current protection mode	Full input range	Auto recovery			
Cooling	Free air convection				
Case material	Metal case				
INPUT CHARACTERISTICS					
parameter	Test conditions	Min	Typ	Max	Units
Startup voltage	12V Input module(9V -18V)	8.8	9	9.3	VDC
Startup voltage	24V Input module(18V-36V)			18	VDC
Startup voltage	48V Input module(36V-72V )			36	VDC
Startup voltage	24V Input module(9V -36V)	8.8	9	9.3	VDC
Startup voltage	48V Input module(18V-72V)			18	VDC
Start rising time	Input rising time from 5%-100%	20			ms
OUTPUT CHARACTERISTICS					
parameter	Test conditions	Min	Typ	Max	Units
Voltage accuracy	Io=0.1...1.0 x Ionom Vi=Vi rated			±1	%
Line regulation	Vimin≤Vi≤Vimax			±0.2	%
Load regulation	Io=0.1...1.0 x Ionom Vimin≤ Vi≤Vimax			±0.5	%
Auxiliary voltage accuracy	Main Load and auxiliary load differ 25%,the auxiliary circuit of the load with at least 25%, the main circuit with full load			±3	%
Ripple and noise	20MHz bandwidth			±1	%
Over-current protection	Vimin≤Vi≤Vimax	120			%
Transient recovery time	25% load change			±5	%
Transient overshoot range	25% load change			400	us
Switch frequency	Vimin≤Vi≤Vimax		300		KHz
ENVIRONMENT CHARACTERISTICS					
parameter	Test conditions	Min	Typ	Max	Units
Storage Humidity	Non condensing	5		+95	%
Operating Temperature	Power derating (above 71°C	-40		+85	°C
Storage Temperature		-55		+125	°C
Max. Case Temperature	Operating Temperature curve range			105	°C
Lead Temperature	1.5mm from case for 10 seconds			300	°C
Cooling	Free air convection				

- Case temperature under shall not exceed the maximum case temperature level.

**MECHANICAL DIMENSIONS** **PIN CONNECTIONS**

**DIP Package**

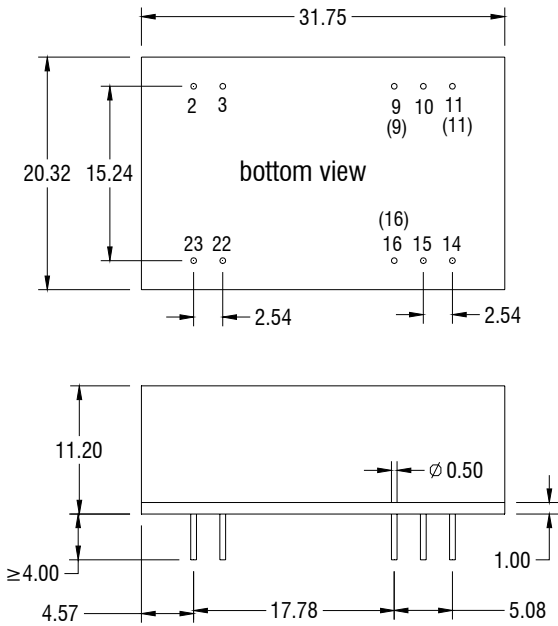

Units: mm  
Tolerance: ±0.2mm

Pin	Single Output	Dual Output
2	-Vin	-Vin
3	-Vin	-Vin
9	NC	
(9)	/	Com
10	NC	NC
11	NC	
(11)	/	-Vout
14	+Vout	+Vout
15	NC	NC
16	-Vout	/
(16)	/	Com
22	+Vin	+Vin
23	+Vin	+Vin

**MODEL SELECTION**

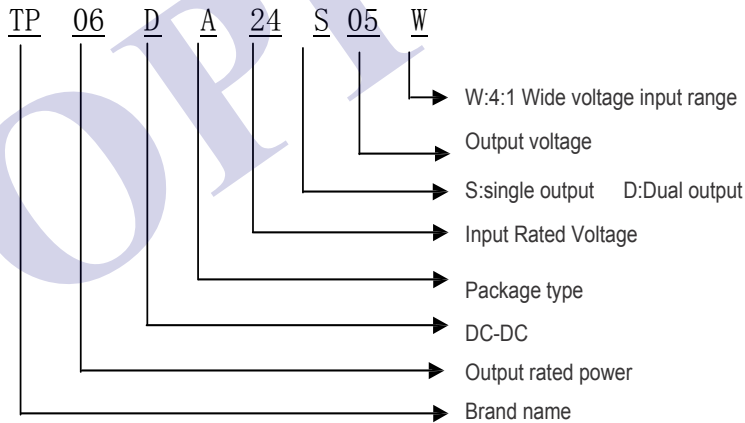

**RECOMMEND CIRCUIT:**

Single Output:

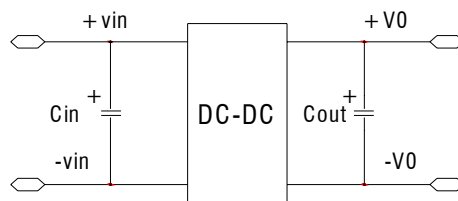

## RECOMMEND CIRCUIT:

Dual Output:

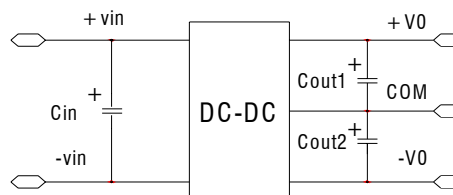

- Add input capacitance  $C_{in}$  is helpful to improve the electromagnetic compatibility, recommend  $C_{in}$  use 47  $\mu\text{F}$ -100 $\mu\text{F}$  of the electrolytic capacitors.
- If the module connect to the digital circuits, please add the  $C_{out}$ ,  $C_{out1}$ ,  $C_{out2}$ .
- If  $C_{out}$ ,  $C_{out1}$ ,  $C_{out2}$  value is too high or lower ESR, it will cause the module instable,
- The recommended value of  $C_{out}$ ,  $C_{out1}$ ,  $C_{out2}$  should be 100  $\mu\text{F}/\text{A}$ , the current here means the output current.

## USING ATTENTIONS

- Module will cause irreversible damage when in the state of the input reverse polarity.
- Module will cause irreversible damage when in the long-term overload conditions.
- Module will cause irreversible damage when out of the maximum input voltage range.

TEMPERATURE DEGRADING OF

TOPPOWER