

Features

- Supply Voltage: 3V to 12V
- Offset Voltage: ±250μV Maximum
- Low Supply Current: 850μA per channel
- Rail to Rail Output
- Bandwidth: 7MHz
- Slew Rate: 20V/μs
- Excellent EMI Suppress Performance
- Offset Voltage Temperature Drift: 2 μV/°C
- Low Noise: 25 nV/√Hz at 1kHz
- -40°C to 125°C Operation Temperature Range

Applications

- Active Filters, ASIC Input or Output Amplifier
- Motor Control
- Industrial Control
- Audio

Description

The TP167X series amplifiers are newest high supply voltage amplifiers with low offset, low power and stable high frequency response. They incorporate 3PEAK's proprietary and patented design techniques to achieve very good AC performance with 7MHz bandwidth, 20V/μs slew rate and low distortion while drawing only 850μA of quiescent current per amplifier. The TP167X family can be used as plug-in replacements for many commercially available op-amps to reduce power and improve input/output range and performance.

The combination of features makes the TP167X ideal choices for industrial control, motor control and portable audio amplification, sound ports, and other consumer Audio.

Pin Configuration

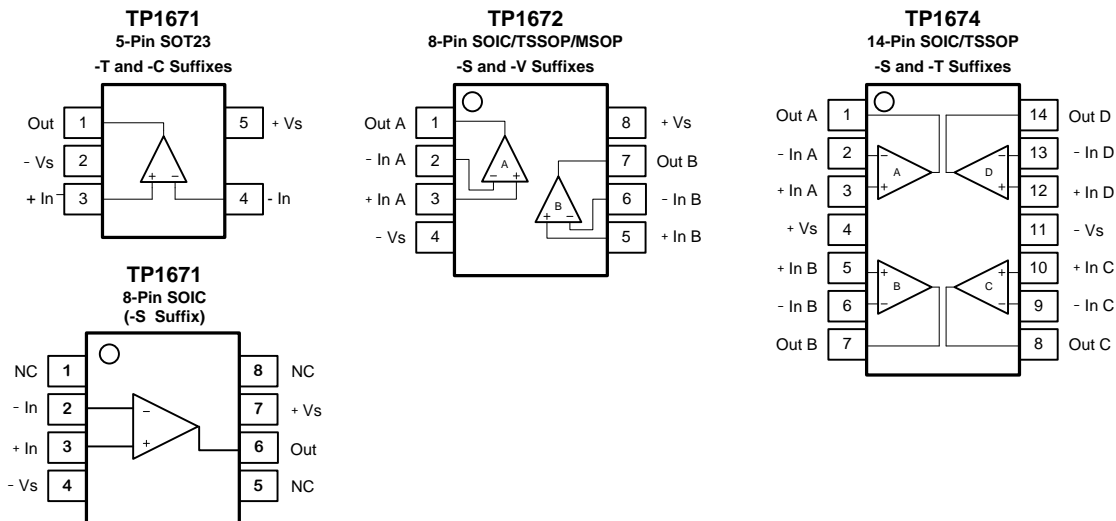

Table of Contents

Features	1
Applications.....	1
Description.....	1
Pin Configuration	1
Table of Contents	2
Revision History	3
Order Information.....	3
Absolute Maximum Ratings ^{Note 1}	4
ESD Rating.....	4
Thermal Information	4
Electrical Characteristics	5
Typical Performance Characteristics	7
Tape and Reel Information	9
Package Outline Dimensions.....	10
SOT23-5.....	10
SOP-8	11
MSOP-8	12
SOP-14	13
TSSOP-14.....	14

Revision History

Date	Revision	Notes
2017/10/20	Rev.Pre	Pre-Release Version
2018/1/10	Rev.0	Initial Version
2018/5/30	Rev.0.01	Update HBM, CDM condition to JS-001 and JS-002
2018/8/31	Rev.A	Add Full Temperature Specification

Order Information

Order Number	Operating Temperature Range	Package	Marking Information	MSL	Transport Media, Quantity
TP1671-SR	-40 to 125°C	8-Pin SOIC	TP1671 XXXX <small>Note 3</small>	3	Tape and Reel, 4000
TP1671-TR	-40 to 125°C	5-Pin SOT23	671XX <small>Note 2</small>	3	Tape and Reel, 3000
TP1672-SR	-40 to 125°C	8-Pin SOIC	TP1672 XXXX <small>Note 3</small>	3	Tape and Reel, 4000
TP1672-VR	-40 to 125°C	8-Pin MSOP	TP1672 XXXX <small>Note 3</small>	3	Tape and Reel, 3000
TP1674-SR	-40 to 125°C	14-Pin SOIC	TP1674 XXXX <small>Note 3</small>	3	Tape and Reel, 2500
TP1674-TR	-40 to 125°C	14-Pin TSSOP	TP1674 XXXX <small>Note 3</small>	3	Tape and Reel, 3000

Note 1: The sample will be ready in 1 month.

Note 2: XX is the date code.

Note 3: XXXX is date code.

Absolute Maximum Ratings ^{Note 1}

Parameters	Rating
Supply Voltage, (+V _S)– (-V _S)	16 V
Input Voltage	(-V _S) – 0.3 to (+V _S) + 0.3
Differential Input Voltage	+– 0.7V
Input Current: +IN, –IN ^{Note 2}	±10mA
Output Short-Circuit Duration ^{Note 3}	Infinite
Maximum Junction Temperature	150°C
Operating Temperature Range	–40 to 125°C
Storage Temperature Range	–65 to 150°C
Lead Temperature (Soldering, 10 sec)	260°C

Note 1: Stresses beyond those listed under Absolute Maximum Ratings may cause permanent damage to the device. Exposure to any Absolute Maximum Rating condition for extended periods may affect device reliability and lifetime.

Note 2: The inputs are protected by ESD protection diodes to each power supply. If the input extends more than 300mV beyond the power supply, the input current should be limited to less than 10mA.

Note 3: A heat sink may be required to keep the junction temperature below the absolute maximum. This depends on the power supply voltage and how many amplifiers are shorted. Thermal resistance varies with the amount of PC board metal connected to the package. The specified values are for short traces connected to the leads.

ESD Rating

Symbol	Parameter	Condition	Minimum Level	Unit
HBM	Human Body Model ESD	ANSI/ESDA/JEDEC JS-001	2	kV
CDM	Charged Device Model ESD	ANSI/ESDA/JEDEC JS-002	1	kV

Thermal Information

Package Type	θ _{JA}	θ _{JC}	Unit
5-Pin SOT23	250	81	°C/W
8-Pin SOIC	158	43	°C/W
8-Pin MSOP	210	45	°C/W
14-Pin SOIC	120	36	°C/W
14-Pin TSSOP	180	35	°C/W

Electrical Characteristics

All test condition is $V_S = 10V$, $T_A = 25^\circ C$, $R_L = 10k\Omega$, unless otherwise noted.

Symbol	Parameter	Conditions	Min	Typ	Max	Unit
Power Supply						
V_S	Supply Voltage Range		3		12	V
I_Q	Quiescent Current per Amplifier	$V_S = 10V$		850	1500	μA
		$V_S = 10V$, $T_A = -40^\circ C$ to $125^\circ C$			2200	μA
PSRR	Power Supply Rejection Ratio	$V_S = 3V$ to $12V$	95	120		dB
		$V_S = 3V$ to $12V$, $T_A = -40^\circ C$ to $125^\circ C$	85			dB
Input Characteristics						
V_{OS}	Input Offset Voltage	$V_S = 10V$, $V_{CM} = 5V$	-250		250	μV
		$V_S = 10V$, $V_{CM} = 5V$, $T_A = -40^\circ C$ to $125^\circ C$	-1		1	mV
		$V_S = 10V$, $V_{CM} = 0V$	-250		250	μV
		$V_S = 10V$, $V_{CM} = 0V$, $T_A = -40^\circ C$ to $85^\circ C$	-1		1	mV
		$V_S = 10V$, $V_{CM} = 0V$, $T_A = -40^\circ C$ to $125^\circ C$	-5		5	mV
$V_{OS\ TC}$	Input Offset Voltage Drift	$T_A = -40^\circ C$ to $125^\circ C$		2		μV/°C
I_B	Input Bias Current	$T_A = 25^\circ C$		10		pA
		$T_A = -40^\circ C$ to $85^\circ C$		200		pA
		$T_A = -40^\circ C$ to $125^\circ C$		6000		pA
I_{OS}	Input Offset Current			10		pA
C_{IN}	Input Capacitance	Differential Mode		5		pF
		Common Mode		5		pF
A_V	Open-loop Voltage Gain		95	120		dB
		$T_A = -40^\circ C$ to $125^\circ C$	85			dB
V_{CMR}	Common-mode Input Voltage Range		(V-)		(V+) - 2	V
CMRR	Common Mode Rejection Ratio	$V_{CM} = 0V$ to $8V$	95	120		dB
		$V_{CM} = 0V$ to $8V$, $T_A = -40^\circ C$ to $85^\circ C$	85			dB
		$V_{CM} = 0V$ to $8V$, $T_A = -40^\circ C$ to $125^\circ C$	60			dB
Output Characteristics						
V_{OH} , V_{OL}	Maximum Output Voltage Swing	$R_{LOAD} = 100k\Omega$, $T_A = -40^\circ C$ to $125^\circ C$			50	mV
I_{SC}	Output Short-Circuit Current			70		mA
AC Specifications						
GBW	Gain-Bandwidth Product			7		MHz
SR	Slew Rate			20		V/μs
t_{OR}	Overload Recovery			200		ns
t_s	Settling Time, 0.1%	$A_V = -1$, 10V step		0.8		μs
	Settling Time, 0.01%			1		μs
PM	Phase Margin			60		°
GM	Gain Margin			15		dB

Noise Performance					
E_N	Input Voltage Noise	$f = 0.1\text{Hz to } 10\text{Hz}$		3	μV_{RMS}
e_N	Input Voltage Noise Density	$f = 1\text{kHz}$		25	$\text{nV}/\sqrt{\text{Hz}}$
i_N	Input Current Noise	$f = 1\text{kHz}$		2	$\text{fA}/\sqrt{\text{Hz}}$
THD+N	Total Harmonic Distortion and Noise	$f = 1\text{kHz}, A_V = 1, R_L = 2\text{k}\Omega, V_{\text{OUT}} = 1\text{V}_{\text{PP}}$		0.001	%

Typical Performance Characteristics

$V_s = 10V$, $V_{CM} = 5V$, $R_L = \text{Open}$, unless otherwise specified.

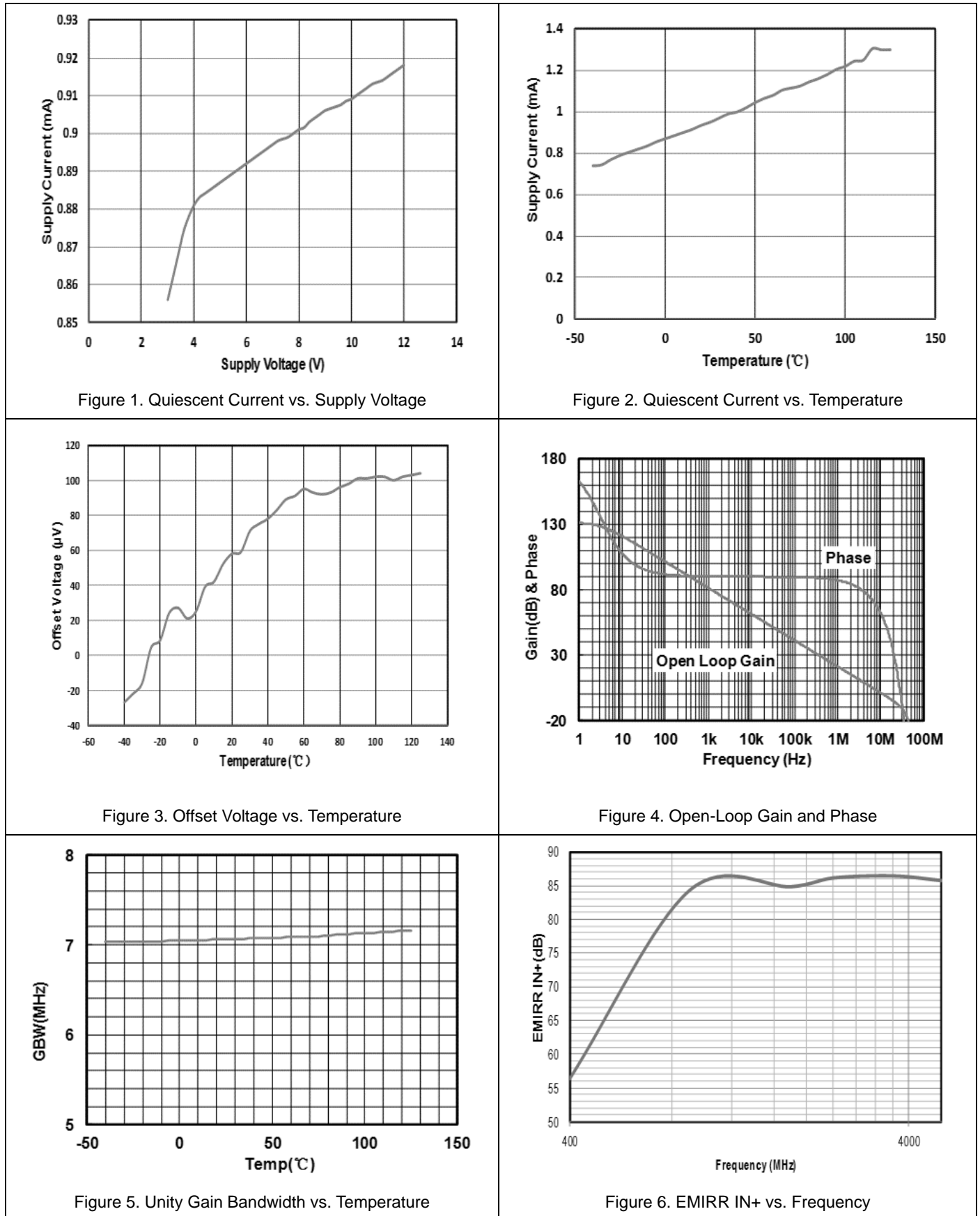

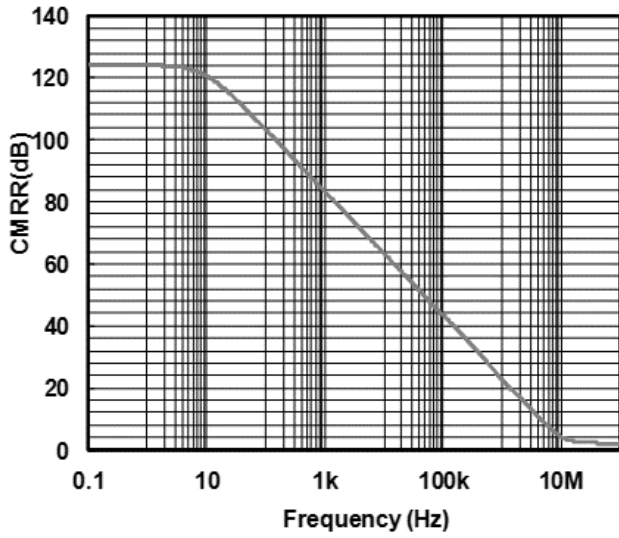

Figure 7. CMRR vs. Frequency

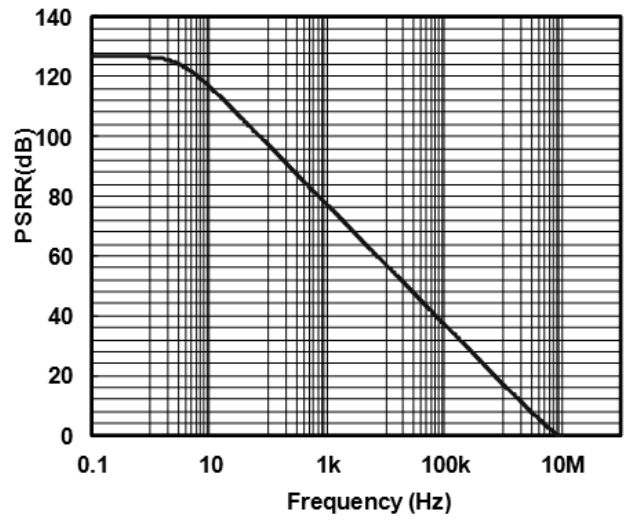

Figure 8. PSRR vs. Frequency

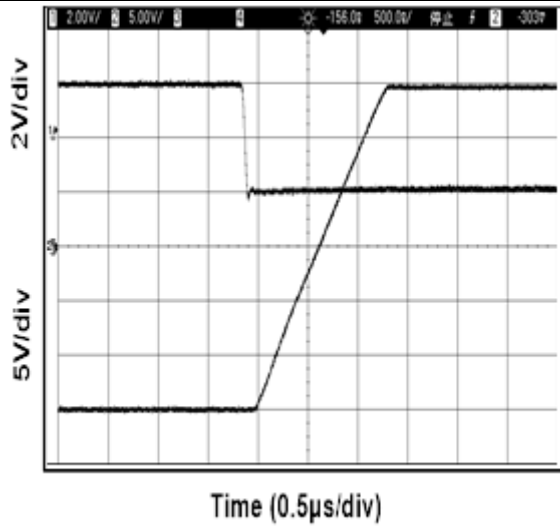

Figure 9. Negative Overload Recovery

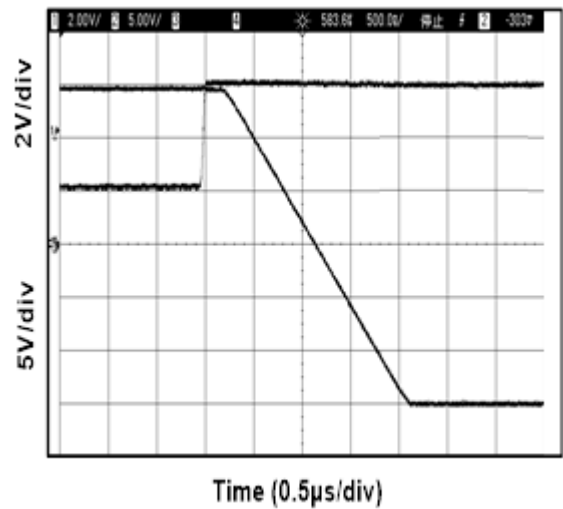
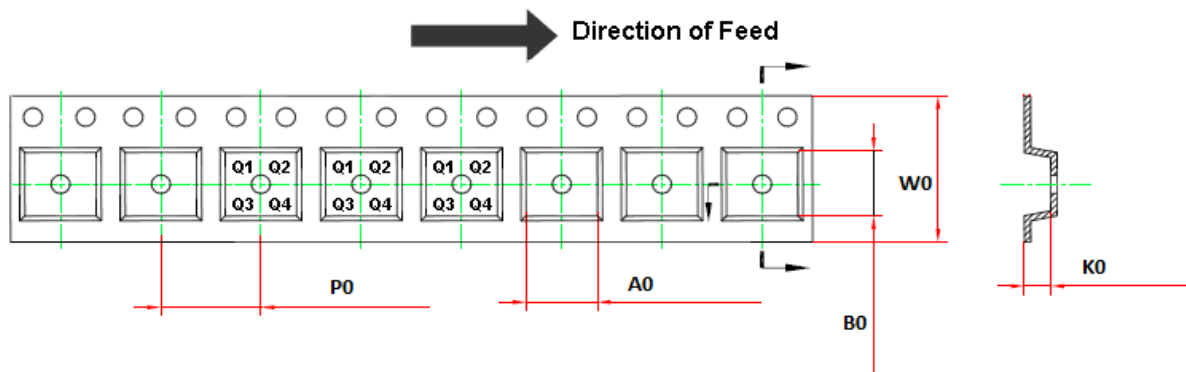
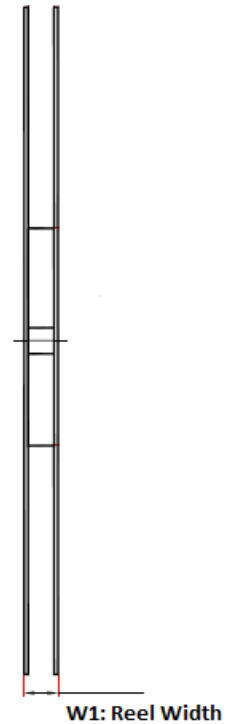
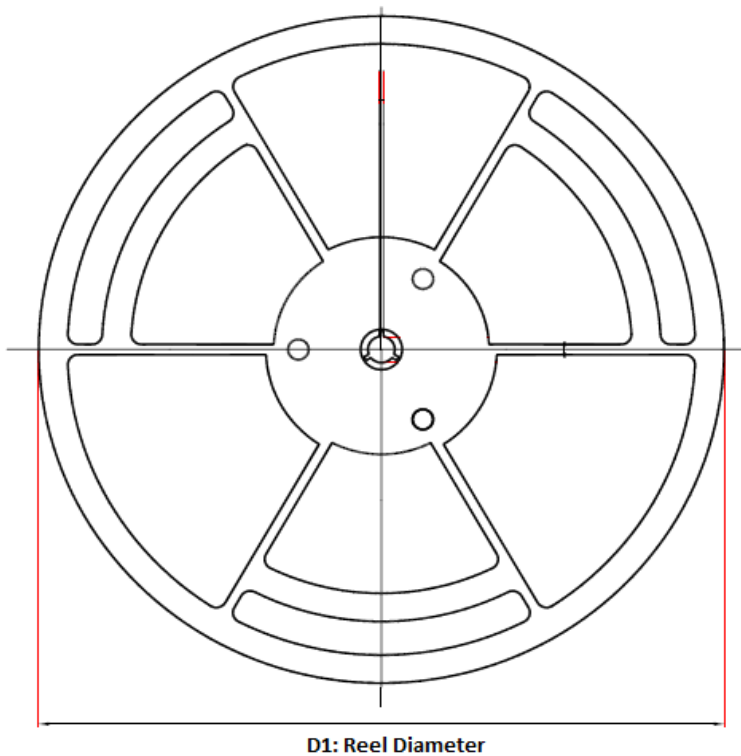

Figure 10. Positive Overload Recovery

Tape and Reel Information



Order Number	Package	D1	W1	A0	B0	K0	P0	W0	Pin1 Quadrant
TP1671-TR	5-Pin SOT23	180.0	13.1	3.2	3.2	1.4	4.0	8.0	Q3
TP1671-SR	8-Pin SOIC	330.0	17.6	6.4	5.4	2.1	8.0	12.0	Q1
TP1672-SR	8-Pin SOIC	330.0	17.6	6.4	5.4	2.1	8.0	12.0	Q1
TP1672-VR	8-Pin MSOP	330.0	17.6	5.2	3.3	1.5	8.0	12.0	Q1
TP1674-SR	14-Pin SOIC	330.0	21.6	6.5	9.0	2.1	8.0	16.0	Q1
TP1674-TR	14-Pin TSSOP	330.0	17.6	6.8	5.4	1.2	8.0	12.0	Q1

Package Outline Dimensions

SOT23-5

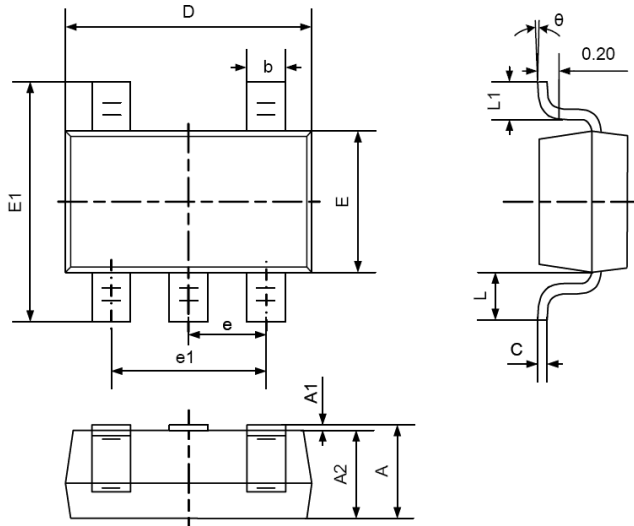

Symbol	Dimensions In Millimeters		Dimensions In Inches	
	Min	Max	Min	Max
A	1.050	1.250	0.041	0.049
A1	0.000	0.100	0.000	0.004
A2	1.050	1.150	0.041	0.045
b	0.300	0.400	0.012	0.016
C	0.100	0.200	0.004	0.008
D	2.820	3.020	0.111	0.119
E	1.500	1.700	0.059	0.067
E1	2.650	2.950	0.104	0.116
e	0.950TYP		0.037TYP	
e1	1.800	2.000	0.071	0.079
L	0.700REF		0.028REF	
L1	0.300	0.460	0.012	0.024
θ	0°	8°	0°	8°

SOP-8

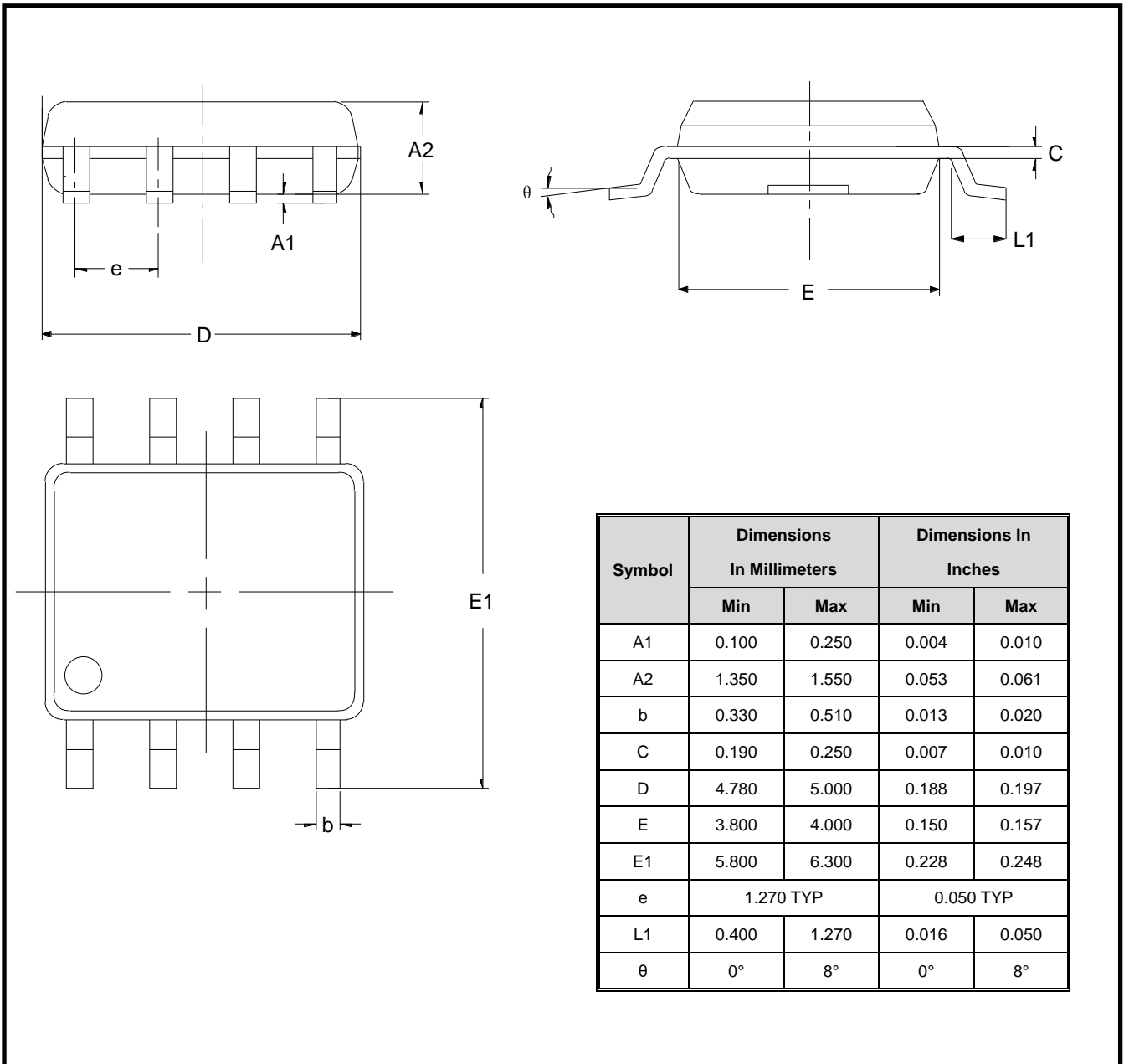

MSOP-8

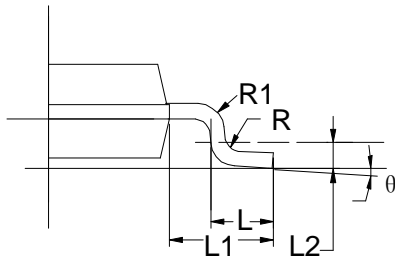
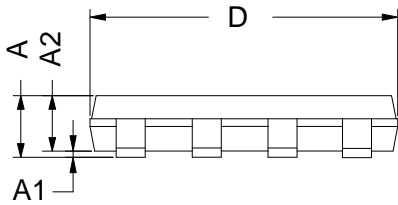
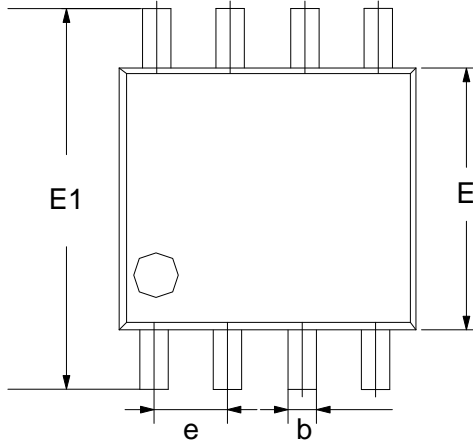

Symbol	Dimensions In Millimeters		Dimensions In Inches	
	Min	Max	Min	Max
A	0.800	1.200	0.031	0.047
A1	0.000	0.200	0.000	0.008
A2	0.760	0.970	0.030	0.038
b	0.30 TYP		0.012 TYP	
C	0.15 TYP		0.006 TYP	
D	2.900	3.100	0.114	0.122
e	0.65 TYP		0.026	
E	2.900	3.100	0.114	0.122
E1	4.700	5.100	0.185	0.201
L1	0.410	0.650	0.016	0.026
θ	0°	6°	0°	6°

SOP-14

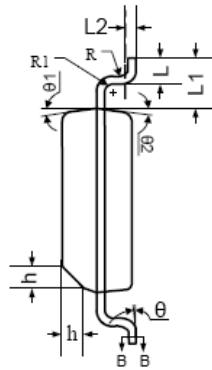
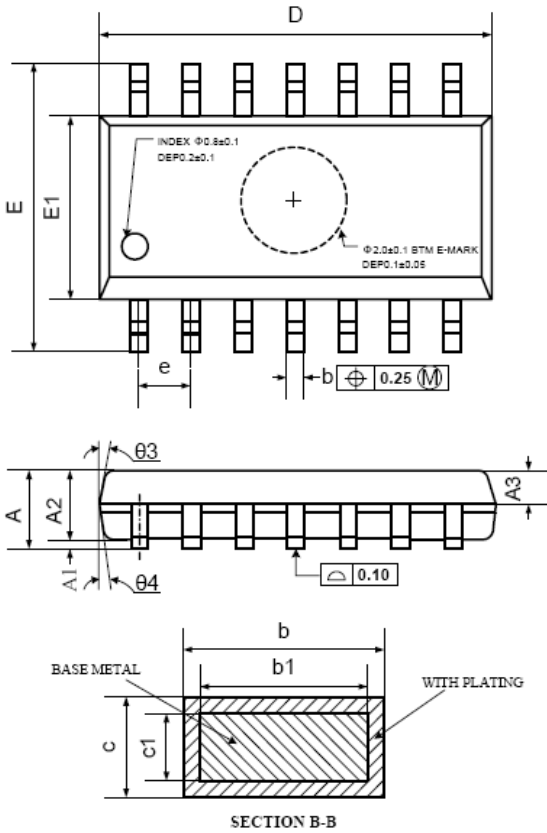

Symbol	Dimensions In Millimeters		
	MIN	NOM	MAX
A	1.35	1.60	1.75
A1	0.10	0.15	0.25
A2	1.25	1.45	1.65
A3	0.55	0.65	0.75
b	0.36		0.49
b1	0.35	0.40	0.45
c	0.16		0.25
c1	0.15	0.20	0.25
D	8.53	8.63	8.73
E	5.80	6.00	6.20
E1	3.80	3.90	4.00
e	1.27 BSC		
L	0.45	0.60	0.80
L1	1.04 REF		
L2	0.25 BSC		
R	0.07		
R1	0.07		
h	0.30	0.40	0.50
θ	0°		8°
$\theta 1$	6°	8°	10°
$\theta 2$	6°	8°	10°
$\theta 3$	5°	7°	9°
$\theta 4$	5°	7°	9°

TSSOP-14

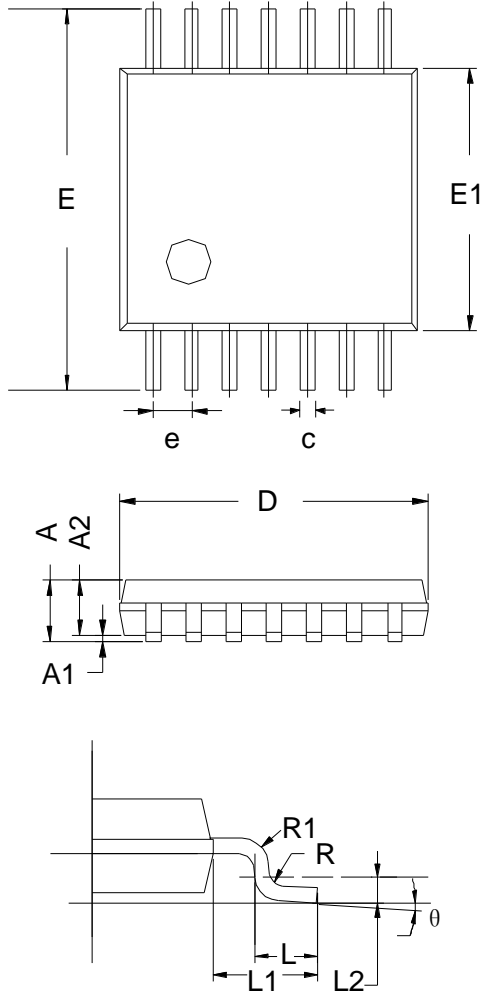

Symbol	Dimensions In Millimeters		
	MIN	TYP	MAX
A	-	-	1.20
A1	0.05	-	0.15
A2	0.90	1.00	1.05
b	0.20	-	0.28
c	0.10	-	0.19
D	4.86	4.96	5.06
E	6.20	6.40	6.60
E1	4.30	4.40	4.50
e	0.65 BSC		
L	0.45	0.60	0.75
L1	1.00 REF		
L2	0.25 BSC		
R	0.09	-	-
θ	0°	-	8°

 ***3PEAK and the 3PEAK logo are registered trademarks of 3PEAK INCORPORATED. All other trademarks are the property of their respective owners.***
