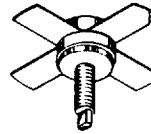

MOTOROLA
SEMICONDUCTOR
TECHNICAL DATA
Advance Information
The RF Line
VHF Power Transistor

The TP2325 is designed for use in 12.5 V VHF amplifiers operating under Class A, B or C conditions.

Its construction which incorporates gold metallization and diffused ballast resistors enables the part to be used at its maximum ratings and be able to withstand an infinite VSWR at all phase angles.

- 175 MHz
- 25 W — P_{out}
- 12.5 V — V_{CC}
- Gold Metallization for Reliability

TP2325
25 W — 175 MHz
VHF POWER
TRANSISTOR
NPN SILICON
2

CASE 145D-01, STYLE 1
(.380 SOE)
MAXIMUM RATINGS

Rating	Symbol	Value	Unit
Collector-Emitter Voltage	V_{CEO}	16	Vdc
Collector-Base Voltage	V_{CBO}	36	Vdc
Emitter-Base Voltage	V_{EBO}	4	Vdc
Collector Current — Continuous	I_C	8	Adc
Operating Junction Temperature	T_J	200	°C
Storage Temperature Range	T_{stg}	- 65 to +200	°C

THERMAL CHARACTERISTICS

Characteristic	Symbol	Max	Unit
Thermal Resistance, Junction to Case	$R_{\theta JC}$	2.2	°C/W

ELECTRICAL CHARACTERISTICS ($T_C = 25^\circ\text{C}$ unless otherwise noted)

Characteristic	Symbol	Min	Typ	Max	Unit
----------------	--------	-----	-----	-----	------

OFF CHARACTERISTICS

Collector-Emitter Breakdown Voltage ($I_C = 50\text{ mA}$, $I_B = 0$)	$V_{(BR)CEO}$	16	—	—	Vdc
Collector-Base Breakdown Voltage ($I_C = 50\text{ mA}$, $I_E = 0$)	$V_{(BR)CBO}$	36	—	—	Vdc
Emitter-Base Breakdown Voltage ($I_E = 5\text{ mA}$, $I_C = 0$)	$V_{(BR)EBO}$	4	—	—	Vdc
Collector Cutoff Current ($V_{CB} = 15\text{ V}$, $I_E = 0$)	I_{CBO}	—	—	5	mAdc
Collector-Emitter Breakdown Voltage ($I_C = 50\text{ mA}$, $R_{BE} = 10\ \Omega$)	$V_{(BR)CER}$	35	—	—	Vdc

ON CHARACTERISTICS

DC Current Gain ($I_C = 1\text{ A}$, $V_{CE} = 5\text{ V}$)	h_{FE}	10	—	—	—
--	----------	----	---	---	---

FUNCTIONAL TESTS

Common-Emitter Amplifier Power Gain ($V_{CE} = 12.5\text{ V}$, $P_{out} = 25\text{ W}$, $f = 175\text{ MHz}$)	G_{PE}	6.2	—	—	dB
Collector Efficiency ($V_{CE} = 12.5\text{ V}$, $P_{out} = 25\text{ W}$, $f = 175\text{ MHz}$)	η_c	60	—	—	%

This document contains information on a new product. Specifications and information herein are subject to change without notice.

The RF Line
VHF Power Transistors

2

The TP2330 device is intended for use in VHF transmitter output stages where high gain is desired.

Use of gold metallization and diffused emitter ballast resistors result in enhanced reliability and ruggedness.

- 175 MHz
- 30 W — P_{out}
- 12.5 V — V_{CC}
- High Gain — 10 dB @ 175 MHz

MAXIMUM RATINGS

Rating	Symbol	Value	Unit
Collector-Emitter Voltage	V_{CEO}	16	Vdc
Collector-Base Voltage	V_{CBO}	36	Vdc
Emitter-Base Voltage	V_{EBO}	4	Vdc
Collector Current — Continuous	I_C	8	Adc
Total Device Dissipation (at $T_C = 25^\circ\text{C}$ Derate above 25°C)	P_D	80 0.46	Watts W/°C
Operating Junction Temperature	T_J	200	°C
Storage Temperature Range	T_{stg}	-65 to +200	°C

THERMAL CHARACTERISTICS

Characteristic	Symbol	Max	Unit
Thermal Resistance, Junction to Case	$R_{\theta JC}$	2.2	°C/W

ELECTRICAL CHARACTERISTICS ($T_C = 25^\circ\text{C}$ unless otherwise noted)

Characteristic	Symbol	Min	Typ	Max	Unit
----------------	--------	-----	-----	-----	------

OFF CHARACTERISTICS

Collector-Emitter Breakdown Voltage ($I_C = 50\text{ mA}$, $I_B = 0$)	$V_{(BR)CEO}$	16	—	—	Vdc
Collector-Base Breakdown Voltage ($I_C = 50\text{ mA}$, $I_E = 0$)	$V_{(BR)CBO}$	36	—	—	Vdc
Emitter-Base Breakdown Voltage ($I_E = 5\text{ mA}$, $I_C = 0$)	$V_{(BR)EBO}$	4	—	—	Vdc
Collector Cutoff Current ($V_{CE} = 15\text{ V}$, $V_{BE} = 0$)	I_{CES}	—	—	10	mAdc

ON CHARACTERISTICS

DC Current Gain ($I_C = 1\text{ A}$, $V_{CE} = 5\text{ V}$)	h_{FE}	20	—	250	—
--	----------	----	---	-----	---

DYNAMIC CHARACTERISTICS

Output Capacitance ($V_{CB} = 15\text{ V}$, $I_E = 0$, $f = 1\text{ MHz}$)	C_{ob}	—	70	100	pF
--	----------	---	----	-----	----

(continued)

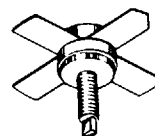
TP2330
TP2330F
30 W — 175 MHz
VHF POWER
TRANSISTORS
NPN SILICON

CASE 145D-01, STYLE 1
(380 SOE)
TP2330

CASE 211-07, STYLE 1
(380 SOE F)
TP2330F

ELECTRICAL CHARACTERISTICS — continued ($T_C = 25^\circ\text{C}$ unless otherwise noted)

Characteristic	Symbol	Min	Typ	Max	Unit	
FUNCTIONAL TESTS						
Common-Emitter Amplifier Power Gain ($V_{CE} = 12.5\text{ V}$, $P_{Out} = 30\text{ W}$, $f = 175\text{ MHz}$)	TP2330 TP2330F	GPE	10 9	— —	— —	dB
Collector Efficiency ($V_{CE} = 12.5\text{ V}$, $P_{Out} = 30\text{ W}$, $f = 175\text{ MHz}$)		η_c	60	—	—	%
Load Mismatch ($V_{CE} = 12.5\text{ V}$, $P_{Out} = 30\text{ W}$, $f = 175\text{ MHz}$, Load VSWR = ∞ 1, All Phase Angles)		ψ	No Degradation in Output Power			
Input Impedance, Common Emitter (Typ) ($V_{CE} = 12.5\text{ V}$, $P_{Out} = 30\text{ W}$, $f = 175\text{ MHz}$)			$Z_{in} = 1.05 + j0.5\text{ Ohms}$			
Load Impedance, Common Emitter (Typ) ($V_{CE} = 12.5\text{ V}$, $P_{Out} = 30\text{ W}$, $f = 175\text{ MHz}$)			$Z_{Load} = 2.7 + j0.2\text{ Ohms}$			

2

TYPICAL CHARACTERISTICS

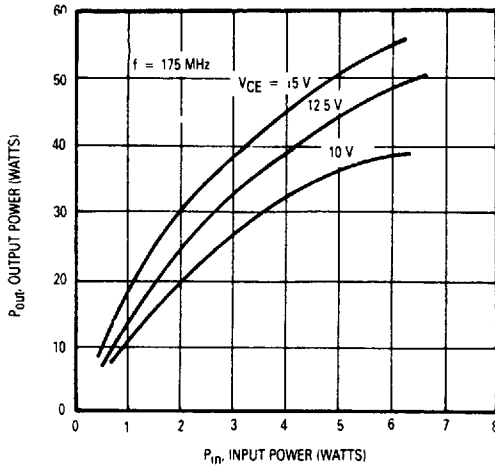

Figure 1. Output Power versus Frequency

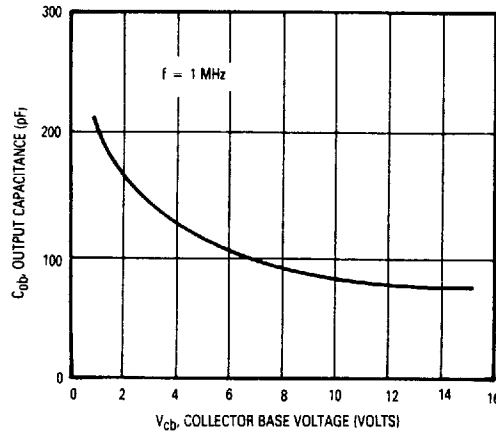

Figure 2. Output Capacitance versus Voltage

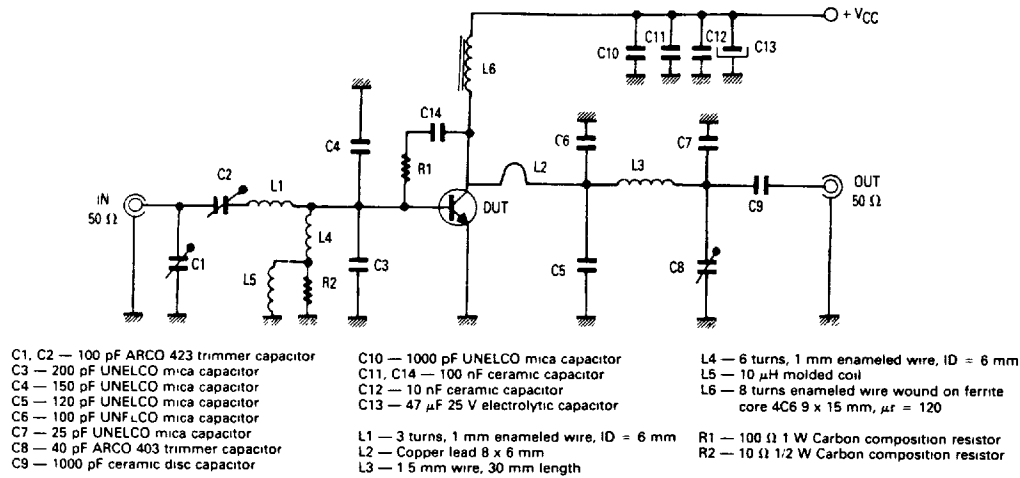

Figure 3. 175 MHz Test Circuit