



# TP4056

## Using SOP8/MSOP8 package 1A Linear Li-Ion Battery Charger

### Description

The TP4056 is a complete constant current & constant voltage linear charger for single cell lithium-ion batteries. Its SOP package and low external component count make the TP4056 ideally suited for portable applications. Furthermore, the TP4056 is specifically designed to work within USB power specifications.

No external sense resistor is needed, and no blocking diode is required due to the internal MOSFET architecture. Thermal feedback regulates the charge current to limit the die temperature during high power operation or high ambient temperature. The charge voltage is fixed at 4.2V, and the charge current can be programmed externally with a single resistor. The TP4056 automatically terminates the charge cycle when the charge current drops to 1/10<sup>th</sup> the programmed value after the final float voltage is reached.

When the input supply (wall adapter or USB supply) is removed, the TP4056 automatically enters a low current state, dropping the battery drain current to less than 2uA. The TP4056 can be put into shutdown mode, reducing the supply current to 50uA.

Other features include Battery temperature monitor, under-voltage lockout, automatic recharge and two status pins to indicate charge and charge termination.

### Applications

- Cellular Telephones, PDAs, MP3 /MP4 Players
- Charging Docks and Cradles
- Bluetooth 、 GPS Applications

### Features

- Programmable Charge Current Up to 1000mA

### Typical Application Circuit

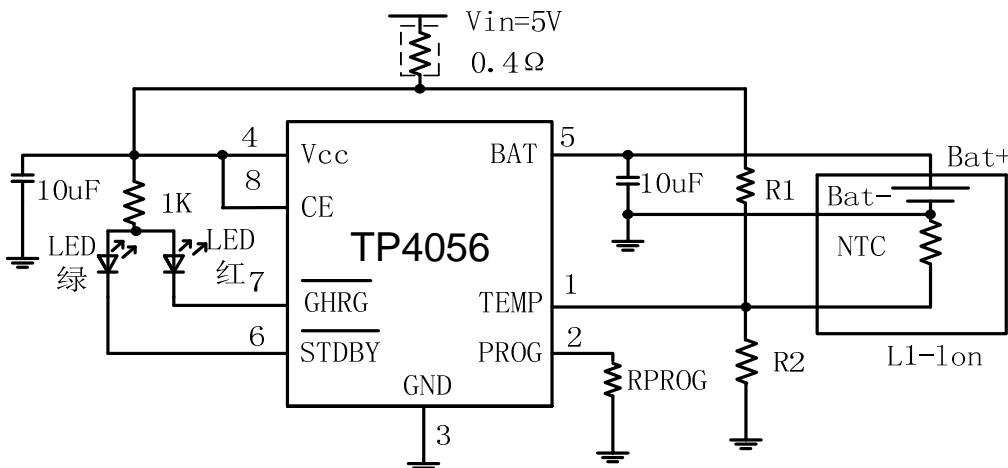

- No MOSFET, Sense Resistor or Blocking Diode Required
- Complete Linear Charger in SOP Package for single Cell Lithium-Ion Batteries
- Constant-Current/Constant-Voltage Operation with Thermal Regulation to Maximize Charge Rate Without Risk of Overheating
- Charges Single Cell Li-Ion Batteries Directly from USB Port
- Preset 4.2V Charge Voltage with  $\pm 1\%$  Accuracy
- Charge Current Monitor Output for Gas Gauging
- Automatic Recharge
- Charge state pairs of output, no battery and fault status display
- C/10 Charge Termination
- 50uA Supply Current in Shutdown
- 2.9V Trickle Charge Threshold
- Soft-Start Limits Inrush Current
- Battery temperature monitoring function
- Available in SOP8-PP/ MSOP8-PP Package

### Package

- SOP8-PP/MSOP8-PP

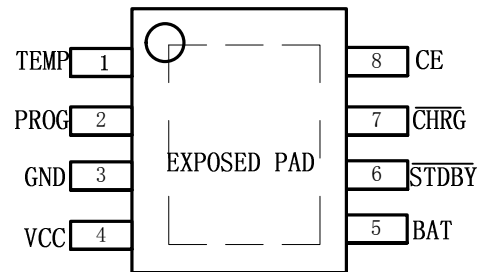

# TP4056

## Block Diagram

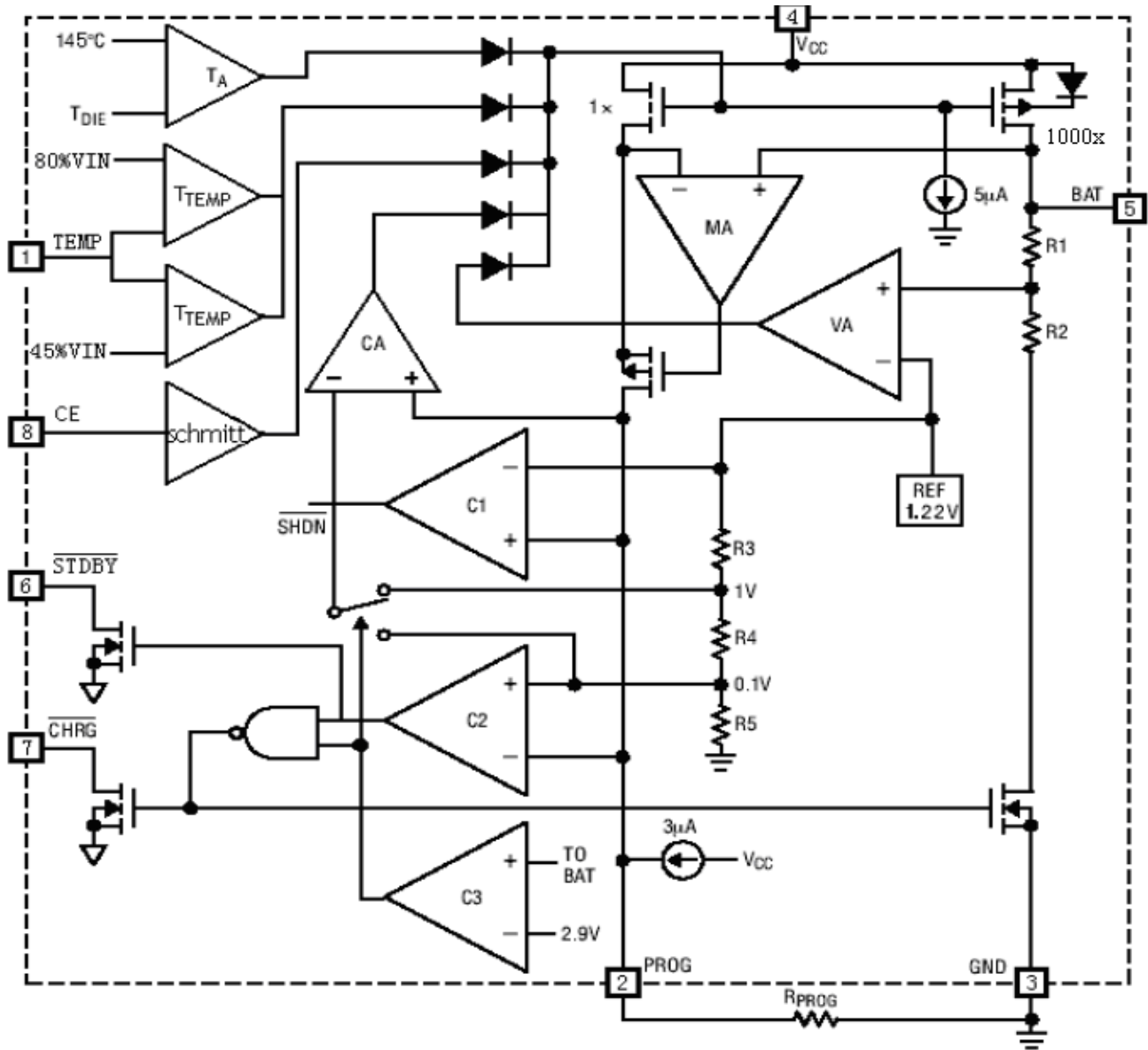

## Absolute Maximum Ratings

PARAMETER	SYMBOL	MAXIMUM RATING	UNIT
Input Supply Voltage	$V_{cc}$	$V_{SS}-0.3 \sim V_{SS}+7$	V
PROG pin Voltage	$V_{prog}$	$V_{SS}-0.3 \sim V_{cc}+0.3$	
BAT pin Voltage	$V_{bat}$	$V_{SS}-0.3 \sim 7$	
CHAG pin Voltage	$V_{chrg}$	$V_{SS}-0.3 \sim V_{SS}+7$	
BAT pin Current	$I_{bat}$	1400	mA
PROG pin Current	$I_{prog}$	1400	$\mu A$
Operating Ambient Temperature	$T_{opa}$	$-40 \sim +85$	$^{\circ}C$
Storage Temperature	$T_{str}$	$-65 \sim +125$	

**Caution:** The absolute maximum ratings are rated values exceeding which the product could suffer physical damage. These values must therefore not be exceeded under any conditions.

# TP4056

## Electrical Characteristics

Parameter	Symbol	CONDITION	MIN	TYP	MAX	UNIT
Input supply voltage	Vcc		4.25		6.5	V
Input supply current	Icc	Charge mode, R <sub>PROG</sub> =10K		350	2000	uA
		Standby mode		150	500	uA
		Shutdown mode(R <sub>PROG</sub> not connected, Vcc<Vbat or Vcc<Vuv)		50	100	uA
Regulated Output Voltage	Vfloat	0°C ≤ T <sub>A</sub> ≤ 85°C, I <sub>BAT</sub> = 40mA	4.158	4.2	4.242	V
BAT pin Current	Ibat	R <sub>PROG</sub> =2k, Current mode	465	500	535	mA
		R <sub>PROG</sub> =1k, Current mode	934	1000	1070	mA
		Standby mode, Vbat=4.2V	0	-2.5	-6	uA
		Shutdown mode		1	2	uA
		Sleep mode, Vcc=0V		0.3	2	uA
Trickle charge current	Itrikl	Vbat<Vtrikl, Rprog=1k	93	100	107	mA
Trickle charge Threshold Voltage	Vtrikl	R <sub>PROG</sub> =10K, Vbat Rising	2.8	2.9	3.0	V
Trickle voltage hysteresis voltage	Vtrhys	R <sub>PROG</sub> =1k	60	80	110	mV
Vcc Undervoltage lockout Threshold	Vuv	From Vcc low to high	3.7	3.8	3.93	V
Vcc undervoltage lockout hysteresis	Vuvhys		150	200	300	mV
Vcc-Vbat Lockout Threshold voltage	Vasd	Vcc from low to high	50	100	140	mV
		Vcc from high to low	5	40	50	mV
C/10 Termination Current Threshold	Iterm	R <sub>PROG</sub> =1k	0.085	0.1	0.115	mA/mA
		R <sub>PROG</sub> =2k	0.085	0.1	0.115	mA/mA
PROG pin Voltage	Vprog	R <sub>PROG</sub> =1k, Current mode	0.93	1.0	1.07	V
CHRG pin Output low voltage	Vchrg	Ichrg=5mA		0.35	0.6	V
STDBY pin Output low voltage	Vstdby	Istdby=5mA		0.35	0.6	V
Recharge Battery threshold Voltage	ΔVrecg	V <sub>FLOAT</sub> - V <sub>RECHRG</sub>		100	200	mV
CE high voltage	Vce-h		1.2			V
CE low voltage	Vce-l		.		0.6	V
TEMP pin voltage of the high-end flip	Vtemp-h			80	82	%Vcc
TEMP pin voltage of the low-end flip	Vtemp-l		43	45		%Vcc
Limited temperature patterns in the junction temperature	Tlim			145		°C

# TP4056

## Typical Performance Characteristics

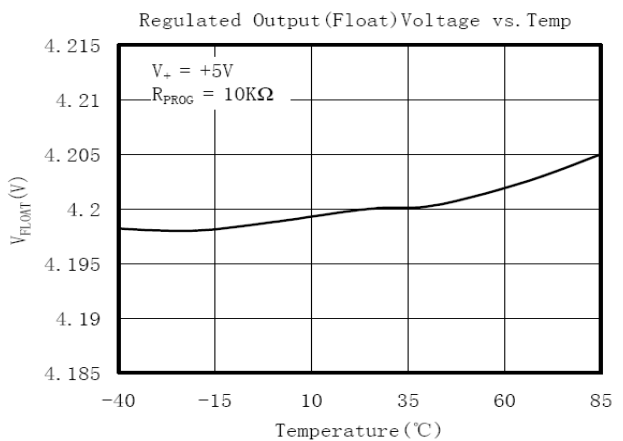
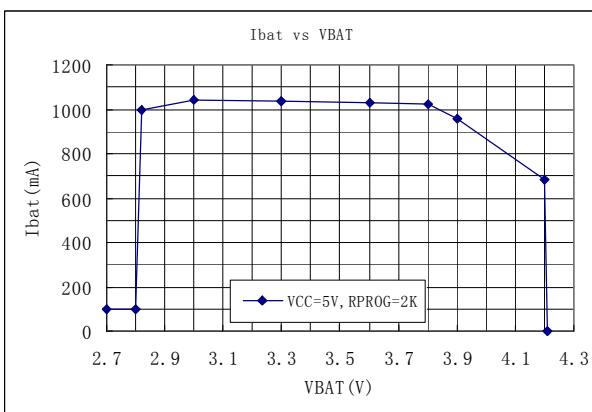
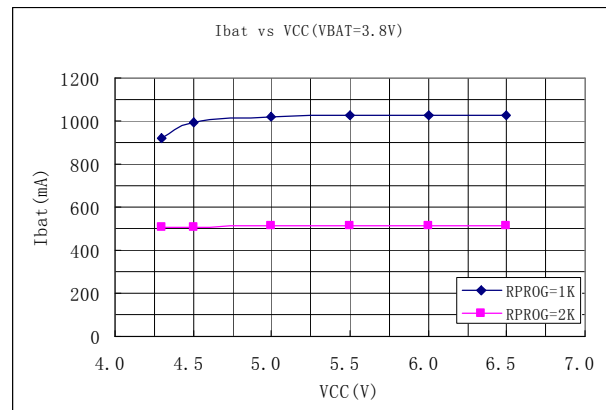
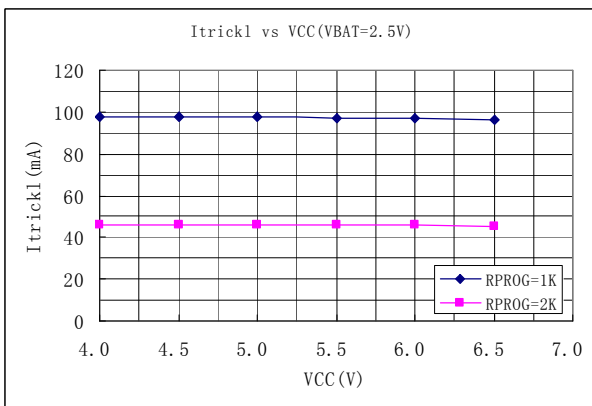
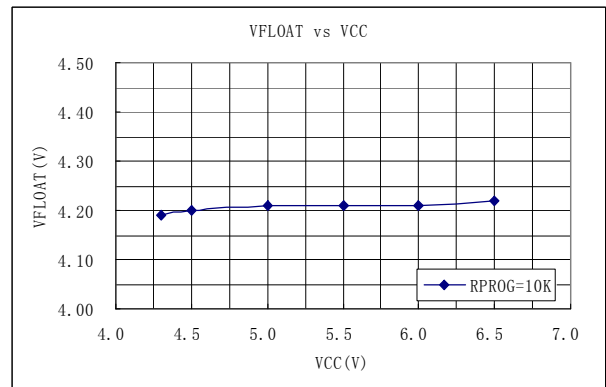
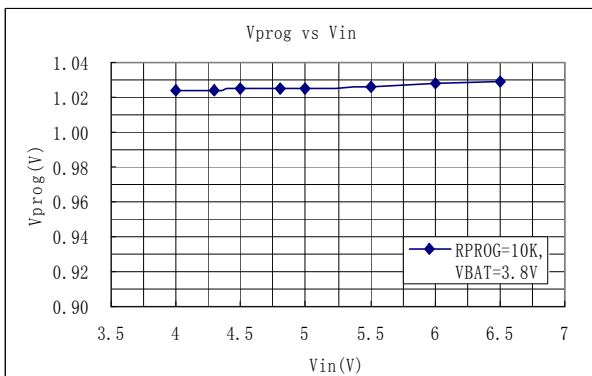

# TP4056

PROG Pin Voltage vs. Temp

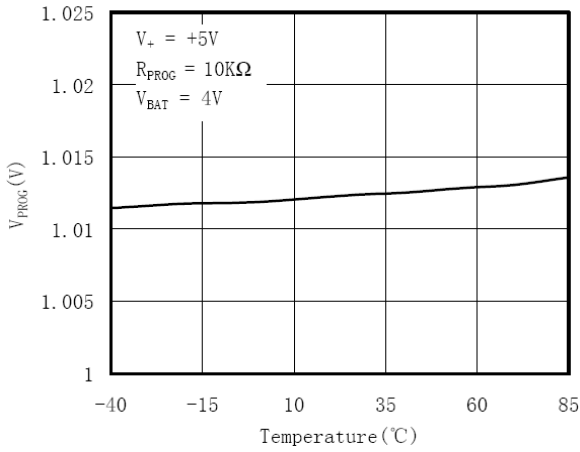

Charge Current vs. PROG Pin Voltage

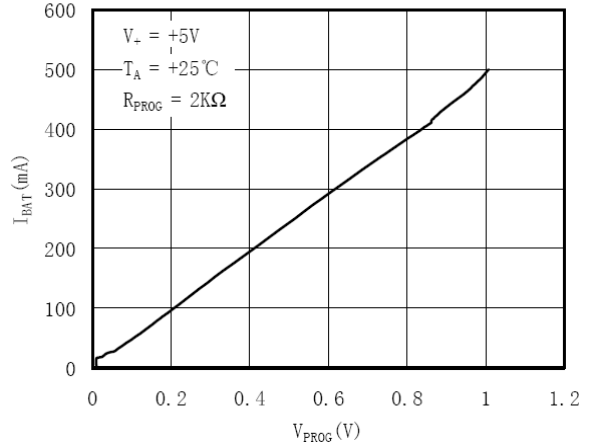

Trickle Charge Threshold vs. Temperature

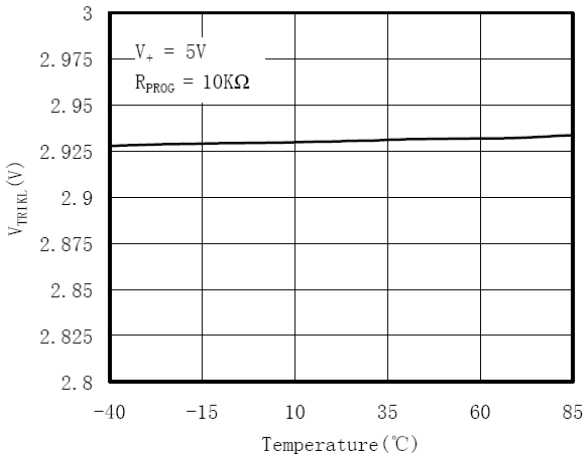

Recharge Voltage Threshold vs. Temperature

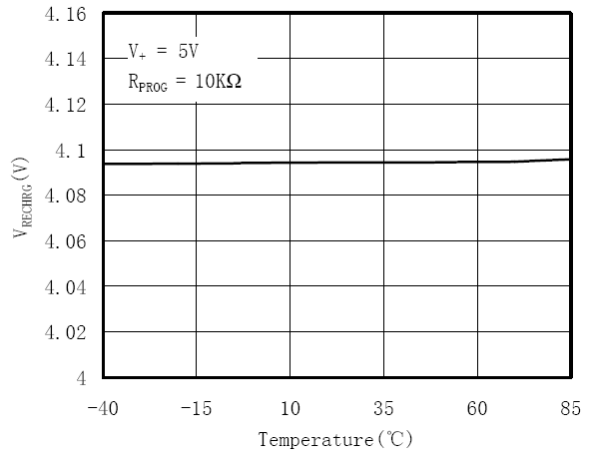

Charge Current vs Ambient Temperature

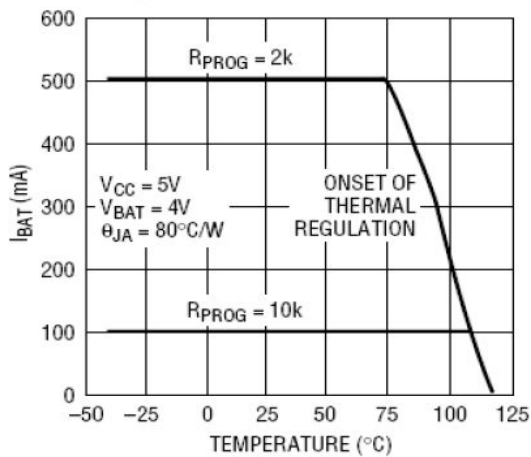

PROG Pin Pull-Up Current vs Temperature and Supply Voltage

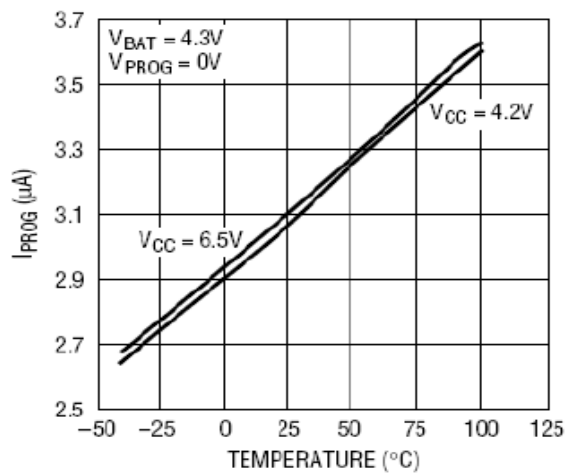

# TP4056

**PROG Pin Current vs PROG Pin Voltage (Pull-Up Current)**

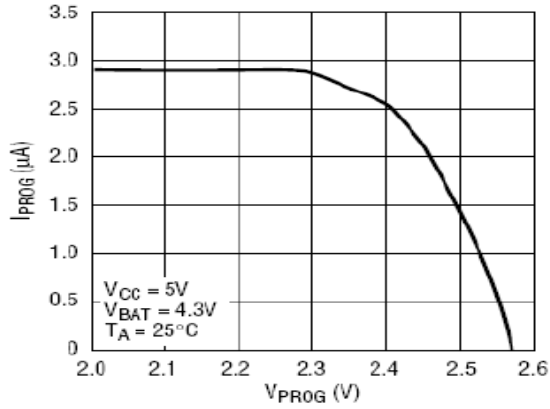

**PROG Pin Current vs PROG Pin Voltage (Clamp Current)**

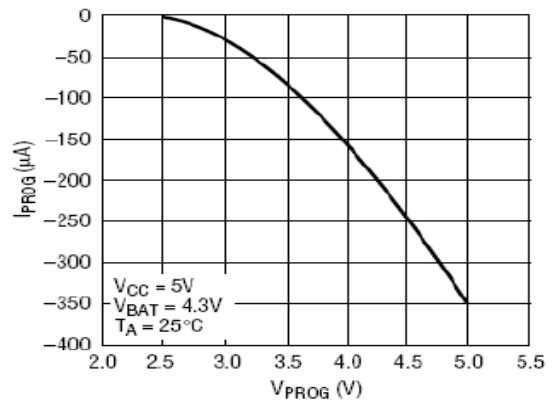

## Ordering Information

Part Number	Top Mark	Package
TP4056	5056 XXYY	SOP8-PP
TP4056IM8P	5056 XXYY	MSOP8-PP

## Pin Configuration

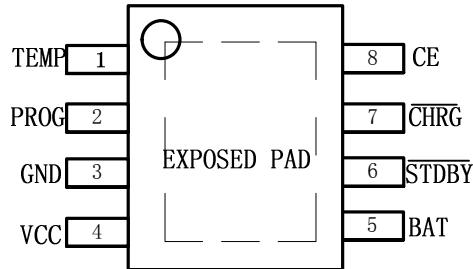

## Pin Assignment

Pin Number	Pin Name
1	TEMP
2	PROG
3	GND
4	VCC
5	BAT
6	STDBY
7	CHRG
8	CE

# TP4056

## Pin Function

**TEMP (Pin 1):** Battery temperature detection input. TEMP pin to receive the battery NTC sensor output. If the TEMP pin voltage is less than the input voltage is greater than 45% or 80% of the input voltage means the battery temperature is too low or too high, then the charge has been suspended.

If the TEMP direct access GND, battery temperature detection canceled, the other charged and functioning properly.

**PROG (Pin 2):** Charge Current Program, Charge Current Monitor and Shutdown Pin. The charge current is programmed by connecting a 1% resistor,  $R_{PROG}$ , to ground. When charging in constant-current mode, this pin serves to 1V. In all modes, the voltage on this pin can be used to measure the charge current using the following formula:

$$I_{BAT} = (V_{PROG}/R_{PROG}) \cdot 1000$$

The  $P_{ROG}$  pin can also be used to shut down the charger. Disconnecting the program resistor from ground allows a 3uA current to pull the  $P_{ROG}$  pin high. When it reaches the 1.21V shutdown threshold voltage, the charger enters shutdown mode, charging stops and the input supply current drops to 50uA. This pin is also clamped to approximately 2.4V. Driving this pin to voltages beyond the clamp voltage will draw currents as high as 1.5mA. Reconnecting  $R_{PROG}$  to ground will return the charger to normal operation.

**GND (Pin 3):** Ground.

**VCC (Pin 4):** Positive Input Supply Voltage. Provides power to the charger, VCC can range from 4.25V to 6.5V and should be bypassed with at least a 10uF capacitor. When VCC drops to within 30mV of the BAT pin voltage, the TP4056 enters shutdown mode, dropping  $I_{BAT}$  to less than 2uA.

**BAT (Pin 5):** Charge Current Output. Provides charge current to the battery and regulates the final float voltage to 4.2V. An internal precision resistor divider from this pin sets the float voltage which is disconnected in shutdown mode.

**STDBY (Pin 6):** The completion of battery charging instructions side. When the battery charge is complete, STDBY pulled low by internal switches, indicating the completion of charging. In addition, STDBY pin will be in a high-impedance state.

**CHRG (Pin 7):** Open-Drain Charge Status Output. When the battery is charging, the CHRG pin is pulled low by an internal N-channel MOSFET. When the charge cycle is completed, CHRG pin will be in a high-impedance state.

**CE (Pin 8):** Chip enable input. High input level would TP4056 is in normal working condition; low input level so that TP4056 is prohibited charging status. CE pin can be TTL or CMOS level-level driver.

# TP4056

## Package Information

SOP8-PP

### SOP8 (EXPOSED PAD)

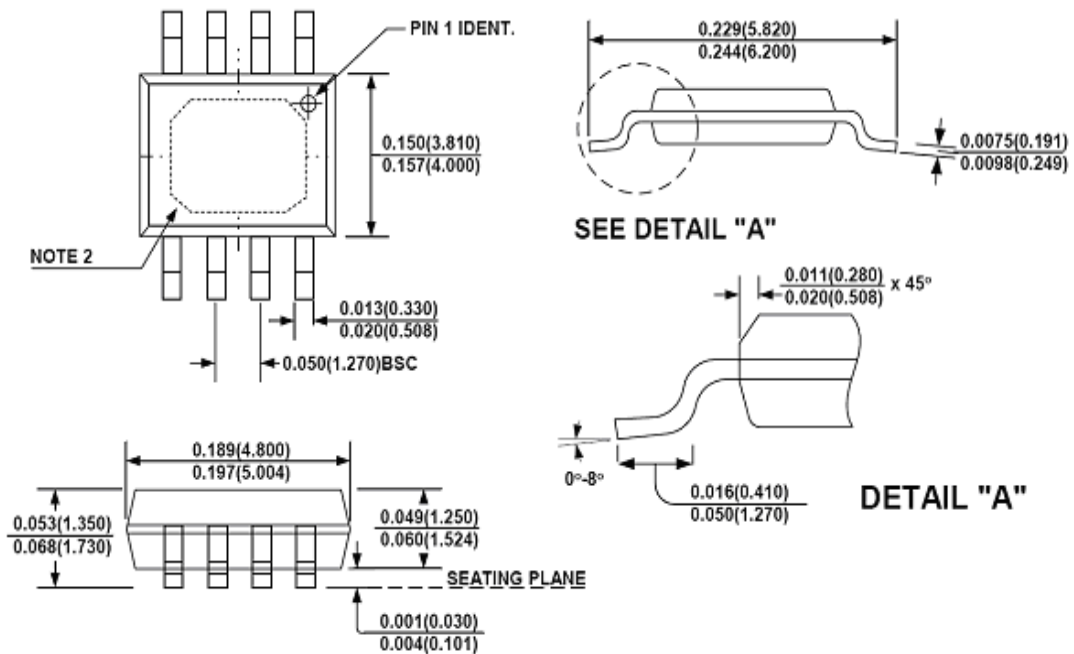

**NOTE:**

- 1) Control dimension is in inches. Dimension in bracket is millimeters.
- 2) Exposed Pad Option Only (N-Package) ; 2.55+/- 0.25mm x 3.38 +/- 0.44mm.  
Recommended Solder Board Area: 2.80mm x 3.82mm = 10.7mm<sup>2</sup> (16.6mil<sup>2</sup>)



# TP4056

MSOP8-PP

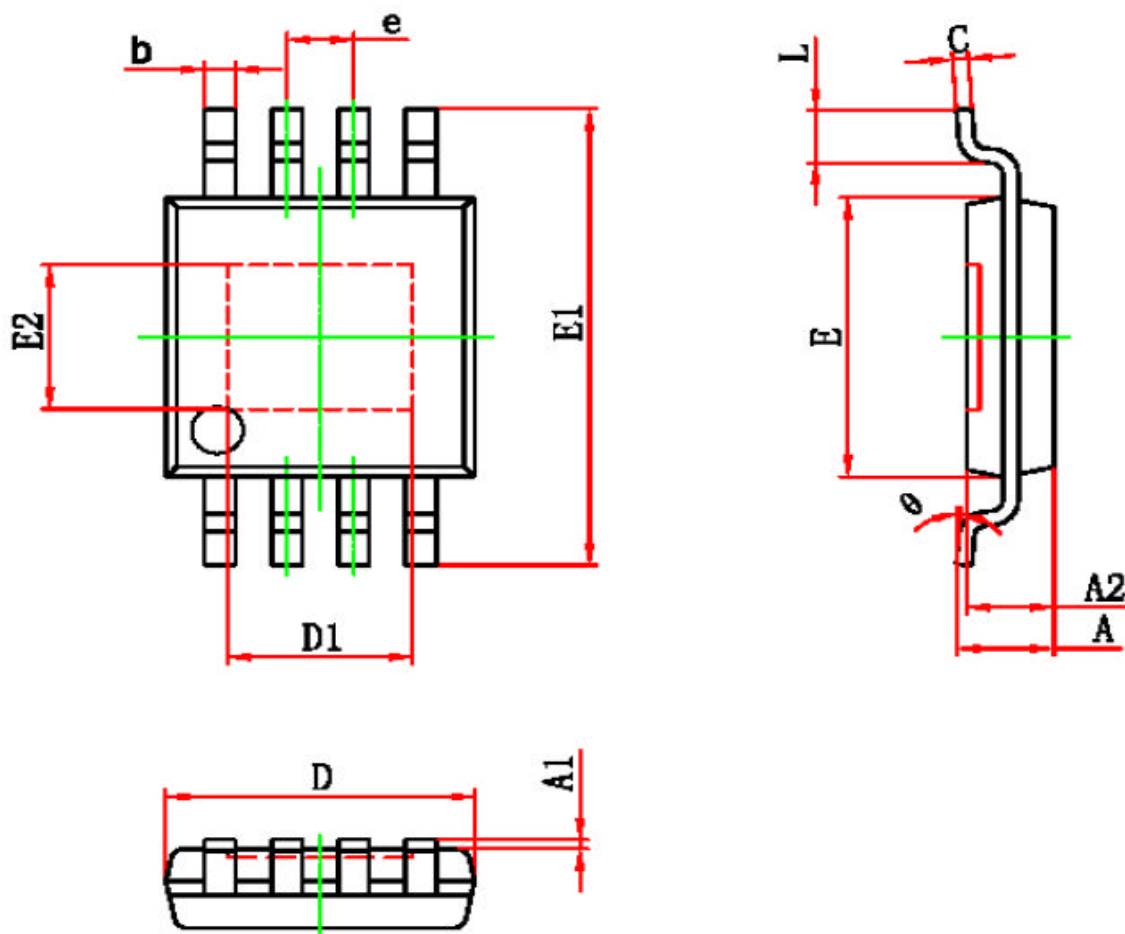

Symbol	Dimensions In Millimeters		Dimensions In Inches	
	Min	Max	Min	Max
A	0.820	1.100	0.032	0.043
A1	0.020	0.150	0.001	0.006
A2	0.750	0.950	0.030	0.037
b	0.250	0.380	0.010	0.015
e	0.090	0.230	0.004	0.009
D	2.900	3.100	0.114	0.122
D1	1.700	1.900	0.067	0.075
e	0.65 (BSC)		0.026 (BSC)	
E	2.900	3.100	0.114	0.122
E1	4.750	5.050	0.187	0.199
E2	1.450	1.650	0.057	0.065
L	0.400	0.800	0.016	0.028
$\theta$	0°	6°	0°	6°

# TP4056

## **IMPORTANT NOTICE**

Chipown Microelectronics Co. Ltd. reserves the right to make changes without further notice to any products or specifications herein. Chipown Microelectronics Co. Ltd. does not assume any responsibility for use of any its products for any particular purpose, nor does Chipown Microelectronics Co. Ltd assume any liability arising out of the application or use of any its products or circuits. Chipown Microelectronics Co. Ltd does not convey any license under its patent rights or other rights nor the rights of others.