

650V GaN FET in TO-247 (source tab)

Description

The TP65H050WS 650V, 50mΩ Gallium Nitride (GaN) FET is a normally-off device. It combines state-of-the-art high voltage GaN HEMT and low voltage silicon MOSFET technologies—offering superior reliability and performance.

Transphorm GaN offers improved efficiency over silicon, through lower gate charge, lower crossover loss, and smaller reverse recovery charge.

Related Literature

- [AN0009](#): Recommended External Circuitry for GaN FETs
- [AN0003](#): Printed Circuit Board Layout and Probing
- [AN0010](#): Paralleling GaN FETs

Ordering Information

Part Number	Package	Package Configuration
TP65H050WS	3 Lead TO-247	Source

TP65H050WS
TO-247
(top view)

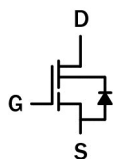
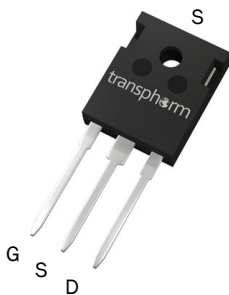

Cascode Schematic Symbol

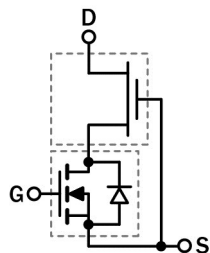

Cascode Device Structure

Features

- JEDEC qualified GaN technology
- Dynamic $R_{DS(on)eff}$ production tested
- Robust design, defined by
 - Intrinsic lifetime tests
 - Wide gate safety margin
 - Transient over-voltage capability
- Very low Q_{RR}
- Reduced crossover loss
- RoHS compliant and Halogen-free packaging

Benefits

- Improves efficiency/operation frequencies over Si
- Enables AC-DC bridgeless totem-pole PFC designs
 - Increased power density
 - Reduced system size and weight
 - Overall lower system cost
- Easy to drive with commonly-used gate drivers
- GSD pin layout improves high speed design

Applications

- Datacom
- Broad industrial
- PV inverter
- Servo motor

Key Specifications	
V_{DSS} (V)	650
$V_{(TR)DSS}$ (V)	800
$R_{DS(on)eff}$ (mΩ) max*	60
Q_{RR} (nC) typ	125
Q_G (nC) typ	16

* Dynamic on-resistance; see Figures 17 and 18

Common Topology Power Recommendations	
CCM bridgeless totem-pole*	3080W max
Hard-switched inverter**	3670W max

Conditions: $F_{SW}=45kHz$; $T_J=115^\circ C$; $T_{HEATSINK}=90^\circ C$; insulator between device and heatsink (6 mil Sil-Pad® K-10); power de-rates at lower voltages with constant current

* $V_{IN}=230V_{AC}$; $V_{OUT}=390V_{DC}$

** $V_{IN}=380V_{DC}$; $V_{OUT}=240V_{AC}$

TP65H050WS

Absolute Maximum Ratings ($T_c=25^\circ\text{C}$ unless otherwise stated.)

Symbol	Parameter	Limit Value	Unit	
V_{DSS}	Drain to source voltage ($T_J = -55^\circ\text{C}$ to 150°C)	650	V	
$V_{(TR)DSS}$	Transient drain to source voltage ^a	800		
V_{GSS}	Gate to source voltage	± 20		
P_D	Maximum power dissipation @ $T_c=25^\circ\text{C}$	119	W	
I_D	Continuous drain current @ $T_c=25^\circ\text{C}$ ^b	36	A	
	Continuous drain current @ $T_c=100^\circ\text{C}$ ^b	25	A	
I_{DM}	Pulsed drain current (pulse width: $10\mu\text{s}$)	150	A	
$(di/dt)_{RDMC}$	Reverse diode di/dt , repetitive ^c	1600	A/ μs	
$(di/dt)_{RDMT}$	Reverse diode di/dt , transient ^d	3000	A/ μs	
T_c	Operating temperature	Case	-55 to +150	$^\circ\text{C}$
T_J		Junction	-55 to +150	$^\circ\text{C}$
T_s	Storage temperature	-55 to +150	$^\circ\text{C}$	
T_{SOLD}	Soldering peak temperature ^e	260	$^\circ\text{C}$	
-	Mounting Torque	80	N cm	

Notes:

- In off-state, spike duty cycle $D < 0.01$, spike duration $< 1\mu\text{s}$
- For increased stability at high current operation, see Circuit Implementation on page 3
- Continuous switching operation
- ≤ 300 pulses per second for a total duration ≤ 20 minutes
- For 10 sec., 1.6mm from the case

Thermal Resistance

Symbol	Parameter	Maximum	Unit
$R_{\theta JC}$	Junction-to-case	1.05	$^\circ\text{C}/\text{W}$
$R_{\theta JA}$	Junction-to-ambient	40	$^\circ\text{C}/\text{W}$

TP65H050WS

Circuit Implementation

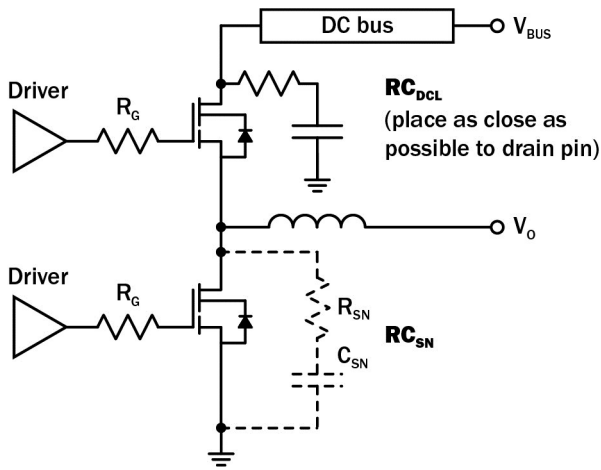

Simplified Half-bridge Schematic

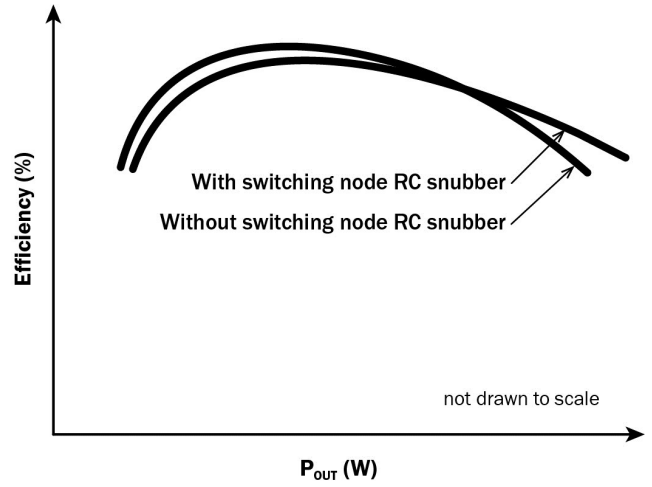

Efficiency vs Output Power

Recommended gate drive: (0V, 12V) with $R_G = 30\text{-}45\Omega$

Required DC Link RC Snubber (RC_{DCL}) ^a	Recommended Switching Node RC Snubber (RC_{SN}) ^{b, c}
$[10\text{nF} + 8\Omega] \times 2$	$100\text{pF} + 10\Omega$

Notes:

- RC_{DCL} should be placed as close as possible to the drain pin
- A switching node RC snubber (C, R) is recommended for high switching currents ($>70\%$ of I_{RDMC1} or I_{RDMC2} ; see page 5 for I_{RDMC1} and I_{RDMC2})
- I_{RDM} values can be increased by increasing R_G and C_{SN}

TP65H050WS

Electrical Parameters (T_J=25 °C unless otherwise stated)

Symbol	Parameter	Min	Typ	Max	Unit	Test Conditions
Forward Device Characteristics						
V _{(BL)DSS}	Drain-source voltage	650	—	—	V	V _{GS} =0V
V _{GS(th)}	Gate threshold voltage	3.3	4	4.8	V	V _{DS} =V _{GS} , I _D =0.7mA
ΔV _{GS(th)/T_J}	Gate threshold voltage temperature coefficient	—	-6.2	—	mV/°C	
R _{DS(on)eff}	Drain-source on-resistance ^a	—	50	60	mΩ	V _{GS} =10V, I _D =22A
		—	103	—		V _{GS} =10V, I _D =22A, T _J =150 °C
I _{DSS}	Drain-to-source leakage current	—	2.5	25	μA	V _{DS} =650V, V _{GS} =0V
		—	10	—		V _{DS} =650V, V _{GS} =0V, T _J =150 °C
I _{GSS}	Gate-to-source forward leakage current	—	—	100	nA	V _{GS} =20V
		—	—	-100		V _{GS} =-20V
C _{ISS}	Input capacitance	—	1000	—	pF	V _{GS} =0V, V _{DS} =400V, f=1MHz
C _{OSS}	Output capacitance	—	130	—		
C _{RSS}	Reverse transfer capacitance	—	8	—		
C _{O(er)}	Output capacitance, energy related ^b	—	190	—	pF	V _{GS} =0V, V _{DS} =0V to 400V
C _{O(tr)}	Output capacitance, time related ^c	—	310	—		
Q _G	Total gate charge	—	16	24	nC	V _{DS} =400V, V _{GS} =0V to 10V, I _D =22A
Q _{GS}	Gate-source charge	—	6	—		
Q _{GD}	Gate-drain charge	—	5	—		
Q _{OSS}	Output charge	—	124	—	nC	V _{GS} =0V, V _{DS} =0V to 400V
t _{D(on)}	Turn-on delay	—	51	—	ns	V _{DS} =400V, V _{GS} =0V to 12V, I _D =22A, R _G = 40Ω
t _R	Rise time	—	11	—		
t _{D(off)}	Turn-off delay	—	86	—		
t _F	Fall time	—	11	—		

Notes:

- Dynamic on-resistance; see Figures 17 and 18 for test circuit and conditions
- Equivalent capacitance to give same stored energy as V_{DS} rises from 0V to 400V
- Equivalent capacitance to give same charging time as V_{DS} rises from 0V to 400V

TP65H050WS

Electrical Parameters (T_J=25 °C unless otherwise stated)

Symbol	Parameter	Min	Typ	Max	Unit	Test Conditions
Reverse Device Characteristics						
I _S	Reverse current	—	—	22	A	V _{GS} =0V, T _C =100 °C, ≤20% duty cycle
V _{SD}	Reverse voltage ^a	—	1.8	2.3	V	V _{GS} =0V, I _S =22A
		—	1.3	1.7		V _{GS} =0V, I _S =11A
t _{RR}	Reverse recovery time	—	54	—	ns	I _S =22A, V _{DD} =400V, di/dt=1000A/μs
Q _{RR}	Reverse recovery charge	—	125	—	nC	
(di/dt) _{RDMC}	Reverse diode di/dt, repetitive ^b	—	—	1600	A/μs	
I _{RDMC1}	Reverse diode switching current, repetitive (dc) ^{c, e}	—	—	24	A	Circuit implementation and parameters on page 3
I _{RDMC2}	Reverse diode switching current, repetitive (ac) ^{c, e}	—	—	28	A	Circuit implementation and parameters on page 3
(di/dt) _{RDMT}	Reverse diode di/dt, transient ^d	—	—	3000	A/μs	
I _{RDMT}	Reverse diode switching current, transient ^{d, e}	—	—	36	A	Circuit implementation and parameters on page 3

Notes:

- Includes dynamic R_{DS(on)} effect
- Continuous switching operation
- Definitions: dc = dc-to-dc converter topologies; ac = inverter and PFC topologies, 50-60Hz line frequency
- ≤300 pulses per second for a total duration ≤20 minutes
- I_{RDM} values can be increased by increasing R_G and C_{SN} on page 3

TP65H050WS

Typical Characteristics ($T_C=25^\circ\text{C}$ unless otherwise stated)

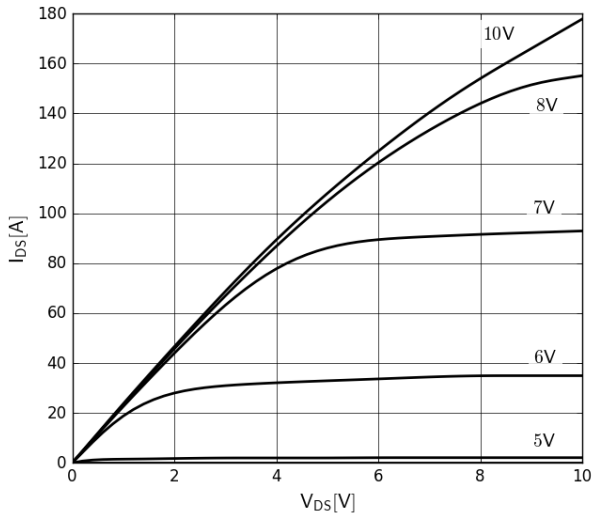

Figure 1. Typical Output Characteristics $T_J=25^\circ\text{C}$
Parameter: V_{GS}

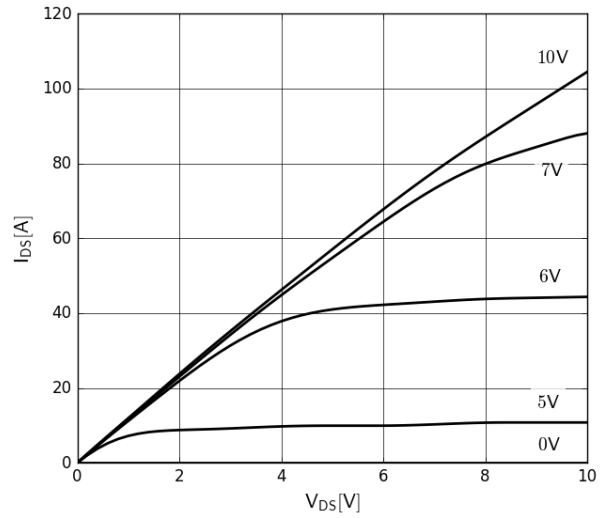

Figure 2. Typical Output Characteristics $T_J=150^\circ\text{C}$
Parameter: V_{GS}

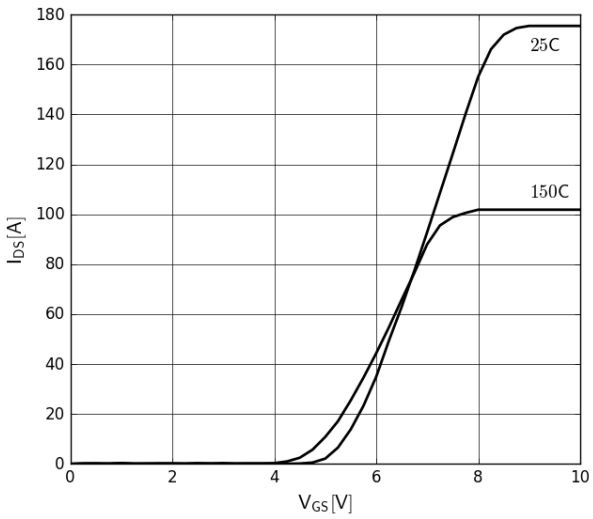

Figure 3. Typical Transfer Characteristics
 $V_{DS}=10\text{V}$, parameter: T_J

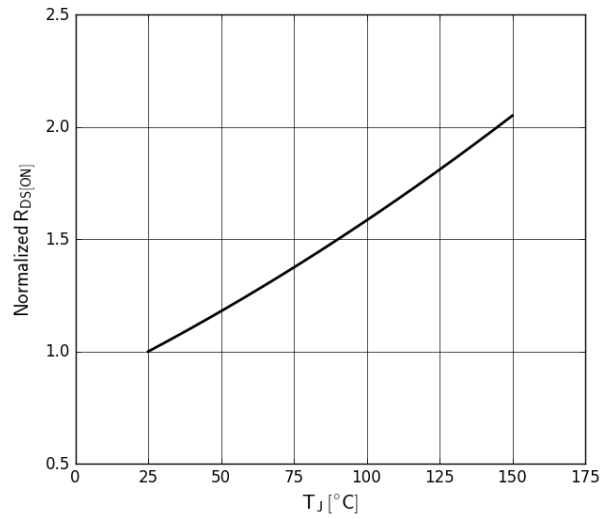

Figure 4. Normalized On-resistance
 $I_D=22\text{A}$, $V_{GS}=10\text{V}$

TP65H050WS

Typical Characteristics ($T_C=25^\circ\text{C}$ unless otherwise stated)

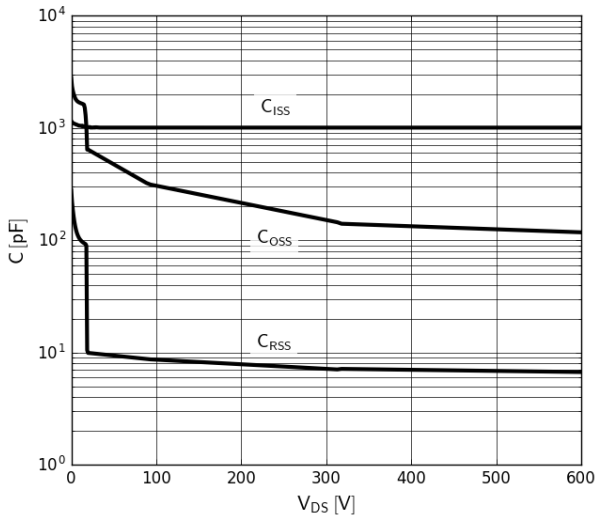

Figure 5. Typical Capacitance

$V_{GS}=0V$, $f=1\text{MHz}$

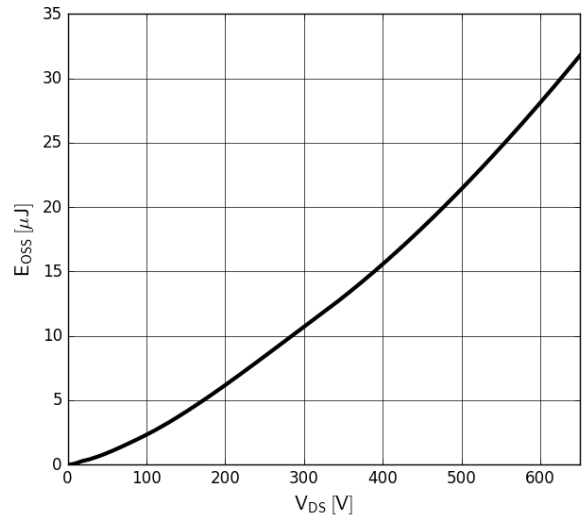

Figure 6. Typical C_{oss} Stored Energy

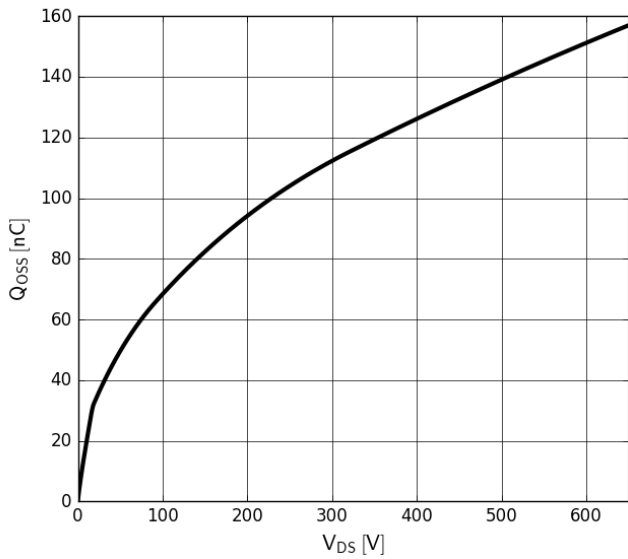

Figure 7. Typical Q_{oss}

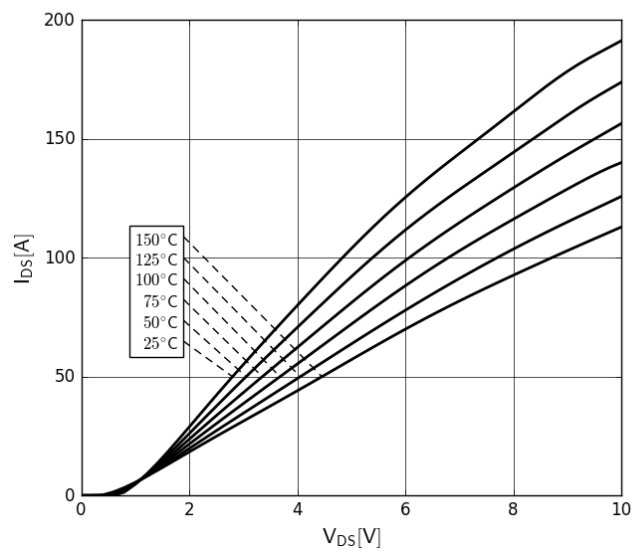

Figure 8. Forward Characteristics of Rev. Diode

$I_S=f(V_{SD})$, parameter: T_J

TP65H050WS

Typical Characteristics ($T_c=25^\circ\text{C}$ unless otherwise stated)

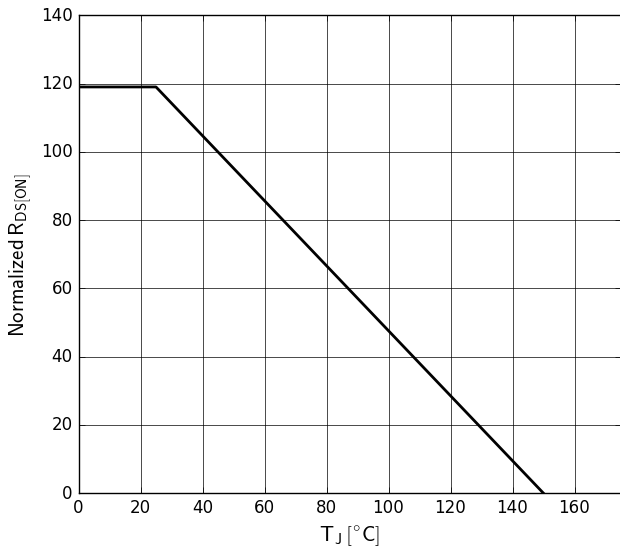

Figure 9. Power Dissipation

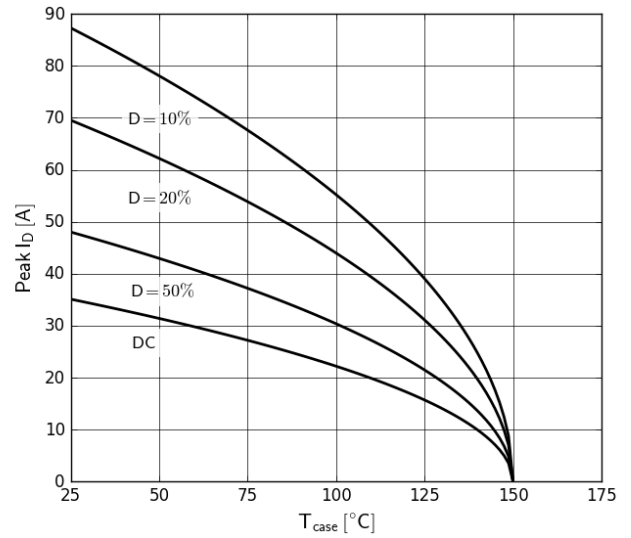

Figure 10. Current Derating
Pulse width $\leq 10\mu\text{s}$, $V_{GS} \geq 10\text{V}$

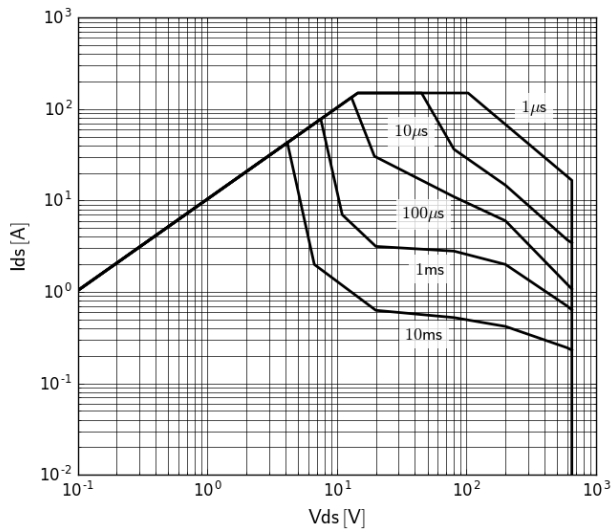

Figure 11. Safe Operating Area $T_c=25^\circ\text{C}$

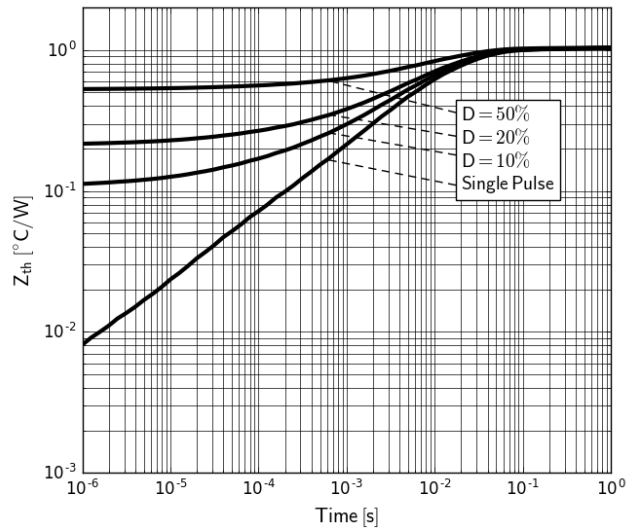

Figure 12. Transient Thermal Resistance

TP65H050WS

Test Circuits and Waveforms

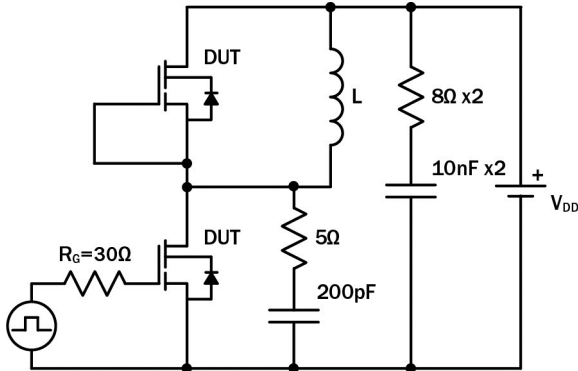

Figure 13. Switching Time Test Circuit
(see circuit implementation on page 3 for methods to ensure clean switching)

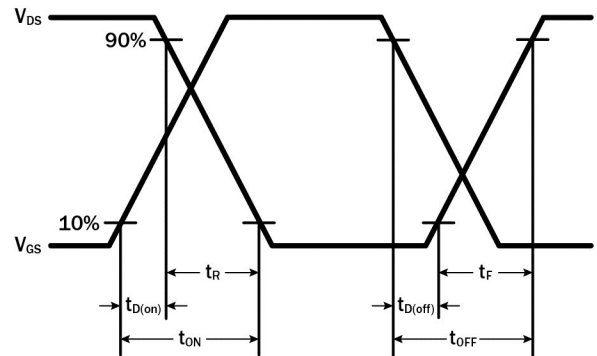

Figure 14. Switching Time Waveform

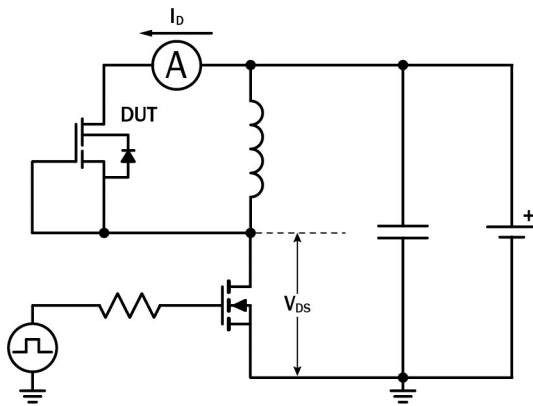

Figure 15. Diode Characteristics Test Circuit

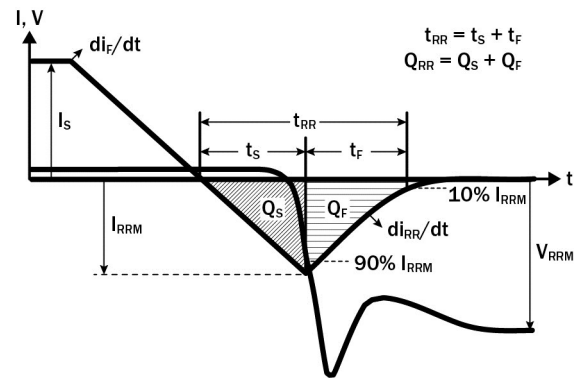

Figure 16. Diode Recovery Waveform

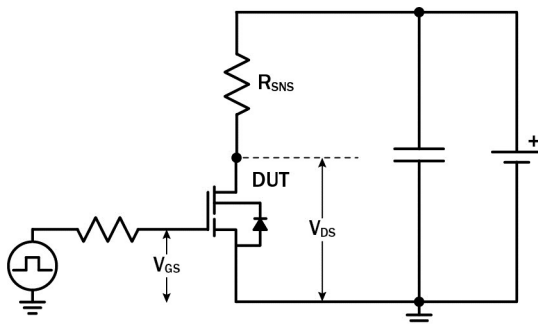

Figure 17. Dynamic $R_{DS(on)eff}$ Test Circuit

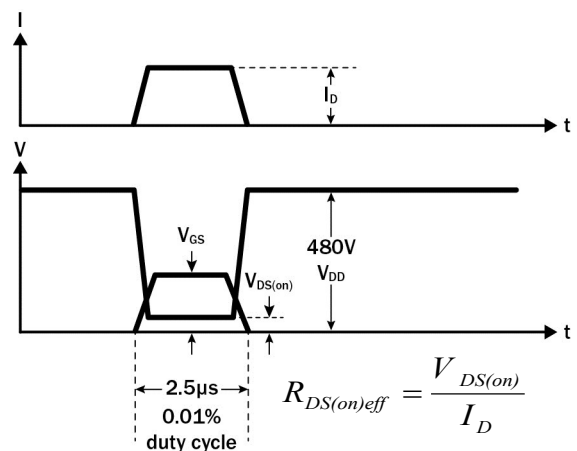

Figure 18. Dynamic $R_{DS(on)eff}$ Waveform

TP65H050WS

Design Considerations

The fast switching of GaN devices reduces current-voltage crossover losses and enables high frequency operation while simultaneously achieving high efficiency. However, taking full advantage of the fast switching characteristics of GaN switches requires adherence to specific PCB layout guidelines and probing techniques.

Before evaluating Transphorm GaN devices, see application note [Printed Circuit Board Layout and Probing for GaN Power Switches](#). The table below provides some practical rules that should be followed during the evaluation.

When Evaluating Transphorm GaN Devices:

DO	DO NOT
Minimize circuit inductance by keeping traces short, both in the drive and power loop	Twist the pins of TO-220 or TO-247 to accommodate GDS board layout
Minimize lead length of TO-220 and TO-247 package when mounting to the PCB	Use long traces in drive circuit, long lead length of the devices
Use shortest sense loop for probing; attach the probe and its ground connection directly to the test points	Use differential mode probe or probe ground clip with long wire
See AN0003 : Printed Circuit Board Layout and Probing	

GaN Design Resources

The complete technical library of GaN design tools can be found at transphormusa.com/design:

- Evaluation kits
- Application notes
- Design guides
- Simulation models
- Technical papers and presentations

TP65H050WS

Mechanical

3 Lead TO-247 Package

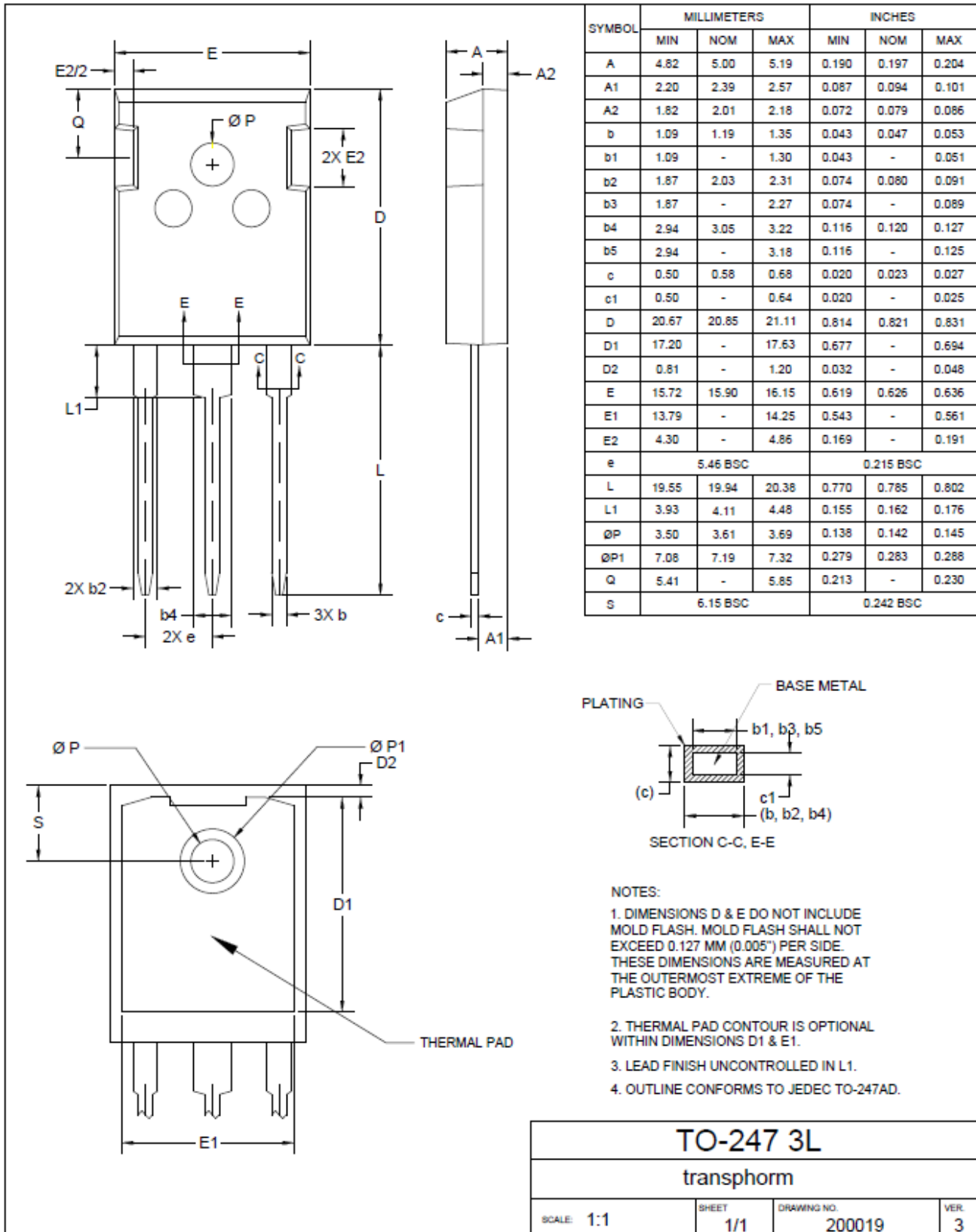

TP65H050WS

Revision History

Version	Date	Change(s)
0	12/6/2017	Initial
1	6/13/2018	Datasheet completed
2	12/21/2018	1) Add max mounting torque 2) Update maximum continuous current 3) Update Qoss 4) Switching with current test condition