



十速科技股份有限公司
tenx technology inc.

**Advance
Information**

TP6825

USB Full Speed Game Pad Controller Data Sheet

**Tenx reserves the right to change or
discontinue this product without notice.**

Contain

1. GENERAL DESCRIPTION..... 2

2. FEATURES..... 2

3. Functional Block Diagram..... 4

4. Pin Description..... 5

5. Package 6

6. Application Circuit 7

7. Electrical Characteristics 8

8. Package Information..... 10

1. GENERAL DESCRIPTION

The TP6825 is an 8051 embedded device tailored to the USB full speed Game Pad controller application. TP6825 was designed for connecting PC or operating at stand-alone (non-PC) mode. It also supports powerful functions and interfaces, such as USB Keyboard, USB Mouse, USB Joystick, USB HID control all in one unit for Game Pad control, PWM 2 channels of Pulse Width Modulation for Voice Vibration feedback, master/slave SPI for Serial Flash, RF 2.4G Module control interface, G-sensor control interface.

2. FEATURES

(1). Operation Frequency

- FAST mode: 24MHz crystal oscillation with internal 48MHz PLL at 5.0V for USB mode
- SLOW mode: Adjustable ext. R/C, RC oscillator at 2.0V~3.6V for battery system (optional)
- STOP mode

(2). On-Chip Memory

- 16k x 8 internal program OTP-ROM
- Internal RAM 256bytes and external XRAM up to 384bytes

(3). USB interface

- Compliance with the Universal Serial Bus specification v2.0 Full Speed
- Built-in USB Transceiver, 3.3V regulator
- Support USB Suspend /Resume and Remote Wakeup function
- Endpoint 0: Control SETUP/IN/OUT transfer (each 8 bytes)
- Endpoint 1: BULK-IN transfer with Pin-Pong feature (2*64 bytes)
- Endpoint 2: BULK-OUT transfer with Pin-Pong feature (2*64 bytes)
- Endpoint 3: BULK-IN transfer (64 bytes)
- Endpoint 4: BULK-OUT transfer (64 bytes)
- Endpoint 5: INTERRUPT IN transfer (8 bytes)

(4). PWM

- Support 2 channels of Pulse Width Modulation (PWM) function with 8-bit resolution

(5). Reset Controller

- Power On Reset, Low Voltage Reset, Watch-Dog Timer, USB Plug-out Reset

(6). Full-Duplex UART interface

- Tx/Rx FIFO (each 8bytes, each 8 depth)
- Baud rate clock up to 3Mbps
- Break function

(7). SPI interface

- Support Mode0, 1, 2, 3
- 1x Master/Slave (Tx FIFO 8*8 bytes, Rx FIFO 8*8 bytes)
- Clock rate up to 6Mbps

(8). Support 32768Hz Crystal pin for Accuracy timing in low power mode (optional)

(9). Keep SRAM data when USB un-plug (need battery)

(10). I/O Ports

- 4 external Interrupts with wakeup function

(11). LQFP48/LQFT64/ Die Form

(12). Application

- USB full speed Game Pad for G-sensor application
- USB full speed Game Pad for RF 2.4G wireless application
- USB full speed Game Pad for MAX. 20 Keys application
- USB full speed Game Pad with Built-in Games application

3. Functional Block Diagram

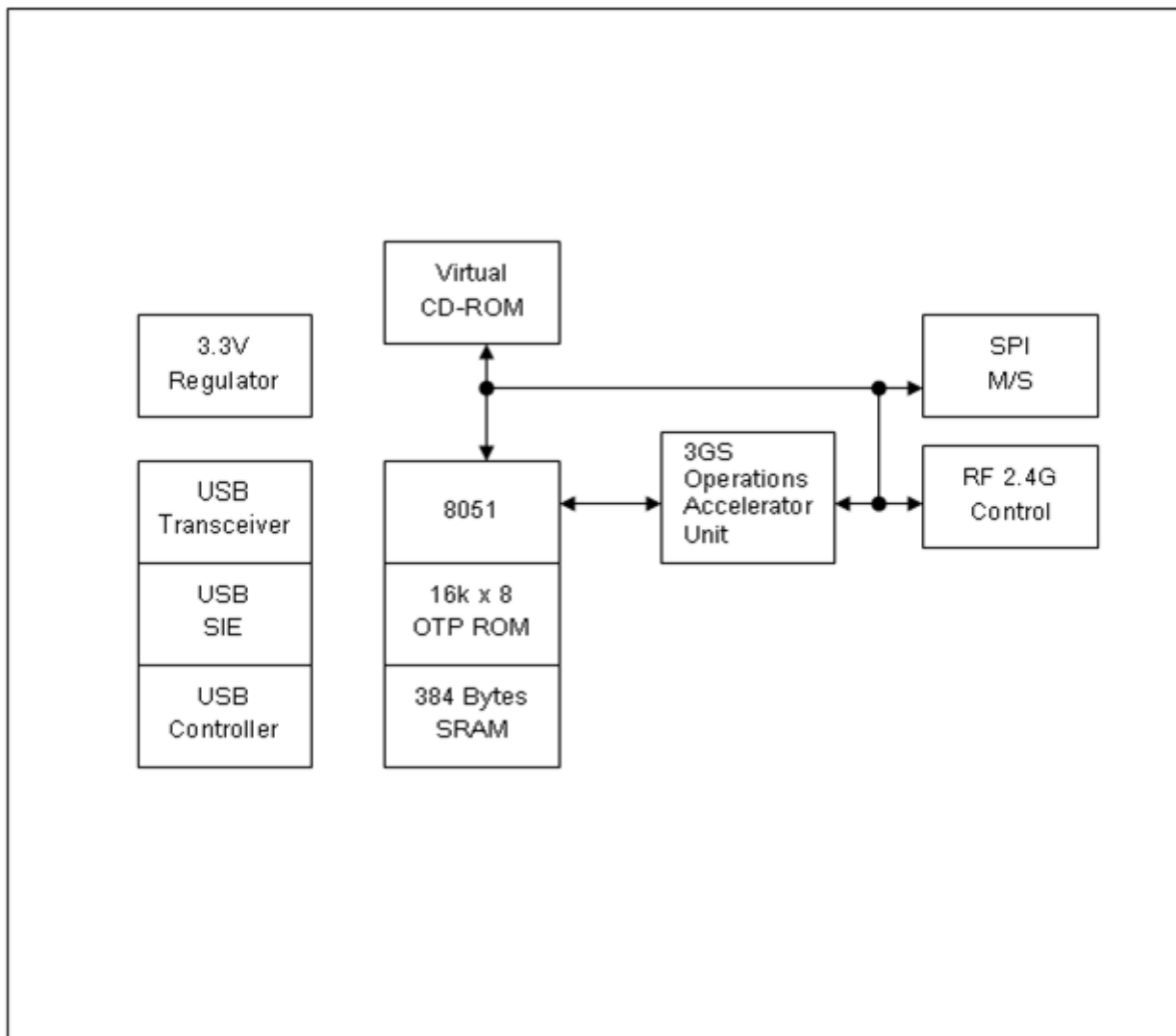

4. Pin Description

Name	I/O	Description
VDD	P	5V Power from USB cable
VSS	P	Ground
VBAT	P	Battery power
VIO	O	Chip I/O voltage, (1.8V/3.0V/3.3V/5V/VBAT by chip configuration)
FX1	I	Crystal in (24MHz)
FX2	O	Crystal out
LX1	I	Crystal in (32KHz)
LX2	O	Crystal out
OSCI	I	RC clock, external capacitor and resistor
VPP/RESETn	I	OTP programming power/Chip reset pin
TESTn[1:0]	I	Test Mode control
V33	O	3.3V regulator output
DP	I/O	USB positive data signal
DM	I/O	USB negative data signal
D[7:0]	I/O	8051's D[0..7]
	I/O	KEY[1..19] Keys
CHR_EN	O	Battery charge enable
CHR_SS		Battery charge state
USB_EN	O	USB enable
RF_PKT	I	RF Packet flag
RF_RST	O	RF Reset
RF_CS	O	RF Chip enable
B_CLK		SPI DATA Clock
B_DO		SPI DATA Output
B_DI		SPI DATA In
RF_CS	O	RF Chip enable
G_CS	O	G-Sensor enable
M_CS	O	Memory enable
POW_EN	O	Low power mode enable
PWMA	O	LED2 and PWMA Output
PWMB	O	LED1 and PWMB Output

All I/O ports are pseudo-open drain type.

I/O voltage fixes 3.3V, unless otherwise specified.

5. Package

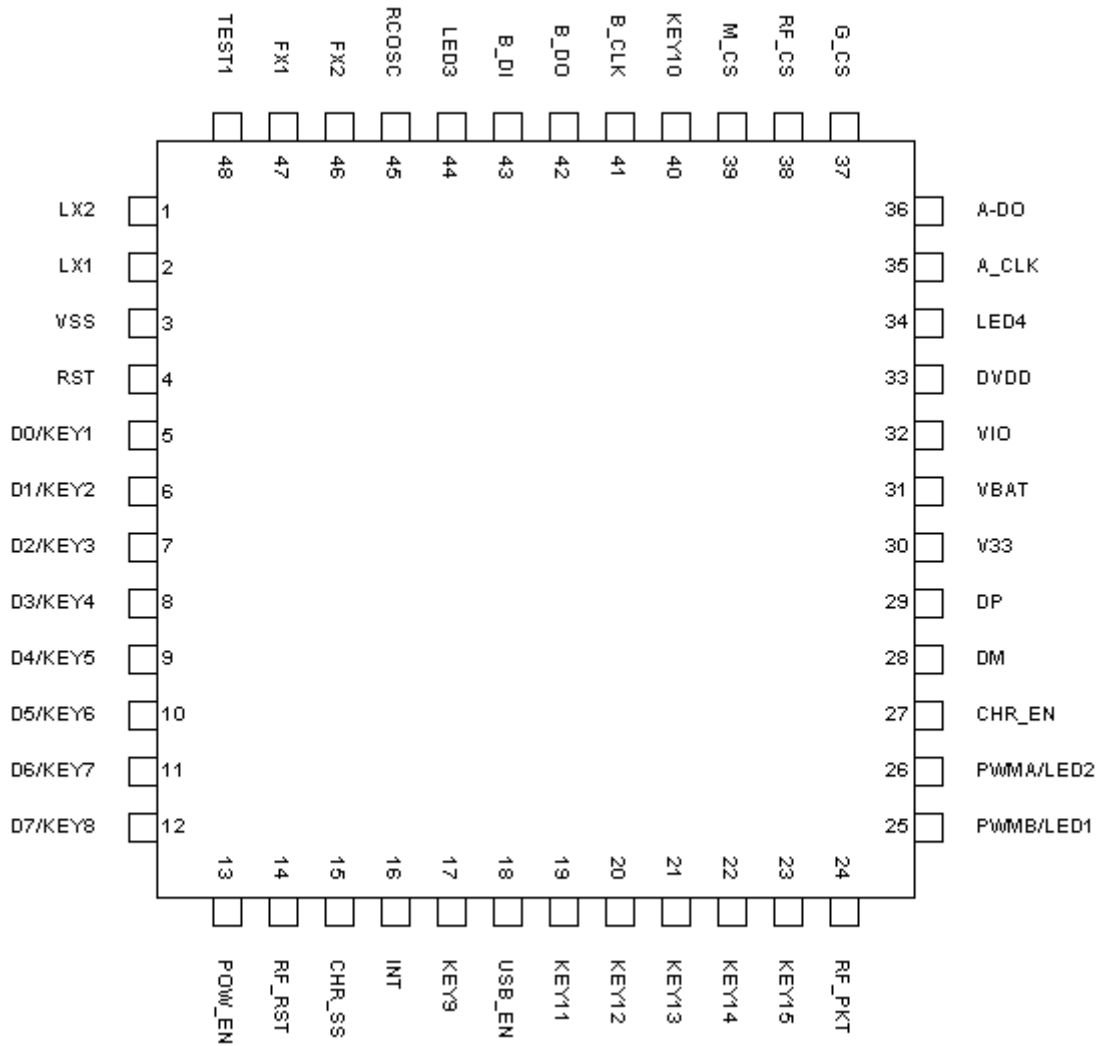

6. Application Circuit

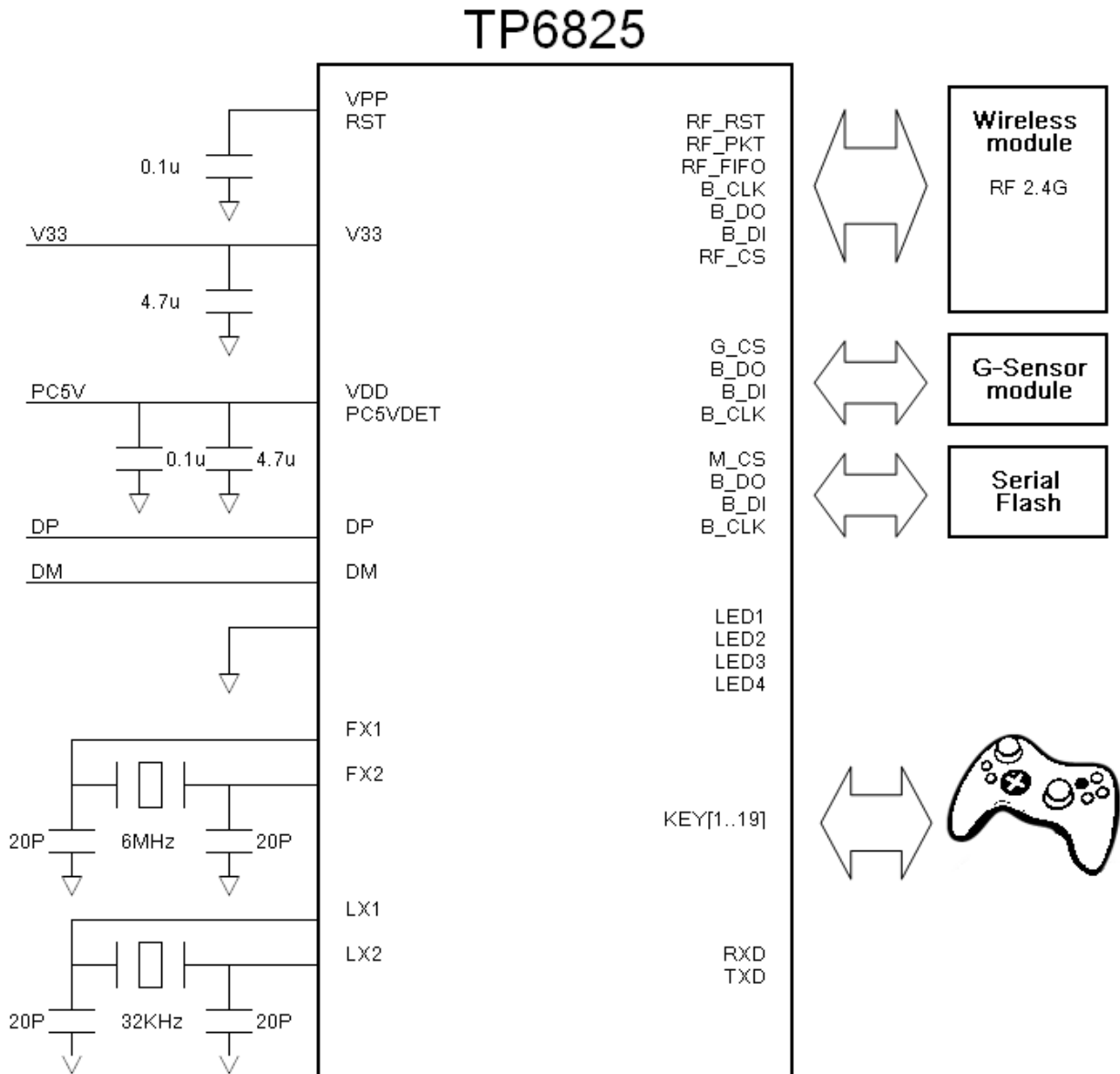

7. Electrical Characteristics

(1). ABSOLUTE MAXIMUM RATINGS (GND = 0V)

Name	Symbol	Range	Unit
Maximum Supply Voltage	VDD	-0.3 to 5.5	V
Maximum Input Voltage	Vin	-0.3 to VDD +0.3	V
Maximum output Voltage	Vout	-0.3 to VDD +0.3	V
Maximum Operating Temperature	Topg	-5 to +70	°C
Maximum Storage Temperature	Tstg	-25 to +125	°C

(2). RECOMMEND OPERATING CONDITION (at Ta = -20°C to 70°C, GND = 0V)

Name	Symb.	Min.	Max.	Unit
Supply Voltage(USB mode)	VDD	4.5	5.5	V
Battery Voltage(battery mode)	Vbat	2.1	4.1	V
Chip I/O Voltage	Vio	1.8	5.5	V
Input "L" Voltage	Vil1	0	0.3xVio	V

(3). DC CHARACTERISTICS (at Ta = 25 °C, VDD = 5.0V, VSS = 0V, Fosc = 24MHz)

Name	Symb.	Min.	Typ.	Max.	Unit	Condition	Note
FAST clock	fclk		24		MHz		
SLOW clock	sclk	-30%	1	+30%	MHz	VBAT=3.0V, VDD=NC ExtC=750pF, ExtR=1K	
Threshold voltage of USB detection	Vdet		4.2		V		
Operating current	Icc1	-	16	-	mA	Fosc=24MHz	No load
	Icc2		1.4		mA	24MHz off, Fosc=1MHz VBAT=3.0V, VDD=N.C.	No load
Suspend current	Isus	-	340	500	uA	USB mode	No load
Power down current	Ipd1			1	uA	RC mode, no 32KHz	No load
	Ipd2		3	5	uA	RC mode with 0.5s wakeup, disable Wakeup Int	No load
Port Output High Current	Ioh1	6			mA	Voh=Vio-0.4V, Vio>=3.0V	One clk time
	Ioh2	8			uA		
	Ioh3	2.6			mA	Voh=Vio-0.4V, Vio =1.8V	One clk time
	Ioh4	4			uA		
Port Output Low Current	Iol1	8			mA	Vol=VSS+0.2V, Vio >=3.0V	
	Iol2	4			mA	Vol=VSS+0.06V, Vio =1.8V	
VIO pin voltage	Vio1	1.7		1.9	V	I=40mA	Vio set 1.8V
	Vio2	2.9		3.1	V	I=80mA	Vio set 3V
	Vio3	3.2		3.4	V	I=120mA	Vio tie to V33
	Vio4	VDD-0.1		VDD	V		Vio set 5V
	Vio5	Vbat-0.1		Vbat	V	No PC5V, battery only	
Port Input High Voltage	Vih	0.55Vio			V	Schmitt trigger	

(4). AC CHARACTERISTICS (at $T_a = 25\text{ }^\circ\text{C}$, $V_{DD5V} = 5.0\text{V}$, $V_{SS} = 0\text{V}$, $F_{osc} = 24\text{MHz}$)

Name	Symb.	Min.	Typ.	Max.	Unit	Note
DP/DM rising time	Trise	4		20	ns	
DP/DM falling time	Tfall	4		20	ns	
DP,DM cross point	Vx	1.3		2.0	V	
V33 output voltage	Vreg	3.2	3.3	3.4	V	
V33 output current	IV33		20	30	mA	

Note: All USB transceiver characteristics can meet USB1.1 spec.

