

# Schottky Barrier Rectifier

# TP805C04

## FEATURES

- With TO-262(I2PAK) packaging
- Low leakage current, low power loss, high efficiency
- High frequency operation
- High current capability
- Low stored charge majority carrier conduction
- Minimum Lot-to-Lot variations for robust device performance and reliable operation

## APPLICATIONS

- Switching power supply
- High frequency inverters
- Freewheeling diodes
- Reverse battery protection
- Polarity protection applications

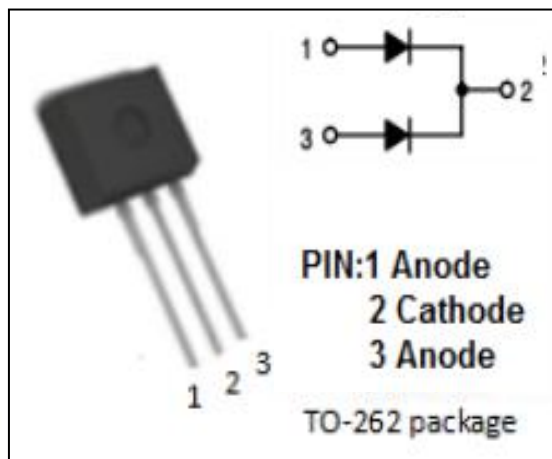

## ABSOLUTE MAXIMUM RATINGS( $T_a=25^{\circ}\text{C}$ )

SYMBOL	PARAMETER	VALUE	UNIT
$V_{RRM}$ $V_{RWM}$ $V_R$	Peak Repetitive Reverse Voltage Working Peak Reverse Voltage DC Blocking Voltage	40	V
$I_{F(AV)}$	Average Rectified Forward Current @ $T_c=92^{\circ}\text{C}$	20	A
$I_{FSM}$	Nonrepetitive Peak Surge Current (Surge applied at rated load conditions half-wave, single phase, 60Hz)	120	A
$P_D$	Total Dissipation	50	W
$T_J$	Junction Temperature	-40~125	$^{\circ}\text{C}$
$T_{stg}$	Storage Temperature Range	-40~125	$^{\circ}\text{C}$

**Schottky Barrier Rectifier**
**TP805C04**
**THERMAL CHARACTERISTICS**

SYMBOL	PARAMETER	MAX	UNIT
$R_{th,j-c}$	Thermal Resistance, Junction to Case	2.0	$^{\circ}\text{C}/\text{W}$

**ELECTRICAL CHARACTERISTICS ( $T_a=25^{\circ}\text{C}$ ) (Pulse Test: Pulse Width=300  $\mu\text{s}$ , Duty Cycle  $\leq 2\%$ )**

SYMBOL	PARAMETER	CONDITIONS	MAX	UNIT
$V_{F^*}$	Maximum Instantaneous Forward Voltage	$I_F=10\text{A}$	0.6	V
$I_{R^*}$	Maximum Instantaneous Reverse Current	$V_R=V_{RWM}$	15	mA

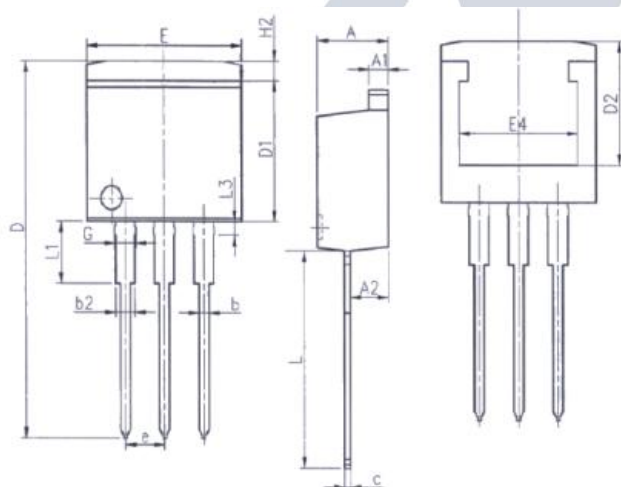
**DIMENSIONAL DRAWING**

Unit: mm		
Symbol	Min.	Max.
A	4.37	4.77
A1	1.22	1.42
A2	2.47	2.87
b	0.70	0.97
b2	1.17	1.42
c	0.28	0.53
D	23.20	24.02
D1	8.38	8.90
D2	6.00	-

Unit: mm		
Symbol	Min.	Max.
E	9.90	10.39
E4	7.30	-
e	2.54BSC	
G	1.25	1.50
H2	-	1.31
L	13.34	14.10
L1	3.30	4.06
L3	0.95	1.15

**NOTICE:**

ISC reserves the rights to make changes of the content herein the datasheet at any time without notification. The information contained herein is presented only as a guide for the applications of our products.

ISC products are intended for usage in general electronic equipment. The products are not designed for use in equipment which require specialized quality and/or reliability, or in equipment which could have applications in hazardous environments, aerospace industry, or medical field. Please contact us if you intend our products to be used in these special applications. ISC makes no warranty or guarantee regarding the suitability of its products for any particular purpose, nor does ISC assume any liability arising from the application or use of any products, and specifically disclaims any and all liability, including without limitation special, consequential or incidental damages.