



2*25W@4Ω TPA3123
Class-D Audio Amplifier Board
User's Guide

Table of Contents

Chapter 1. Overview	1
1.1 Overview	1
1.2 Features	2
1.3 Applications.....	2
1.4 Benefits	3
1.5 Quick Start	3
Chapter 2. Hardware Detail	5
2.1 Power Connection.....	5
2.2 Input Connections.....	5
2.3 Output Connections.....	6
2.4 Connection with Next Board	7
2.5 Mute Settings.....	8
2.6 Sleep Settings	8
2.7 Gain Settings	9
2.8 DC Offset.....	10
2.9 LED Indicators.....	10
2.10 Volume Control.....	11
2.11 Notes	11
Chapter 3. Electrical Characteristics	12
Chapter 4. Mechanical Drawing.....	14
Chapter 5. Appendix	15
Chapter 6. Contact Us	16

2*25W @4Ω TPA3123 Class-D Audio Amplifier Board

NOTES:

Product Version : Ver 1.0

Document Version : Ver 1.0

Chapter 1. Overview

1.1 Overview

Welcome to use this 2*25W amplifier board from Sure Electronics. Sure has developed many Class-D amplifiers such as 0.5W, 2W, 8W, 15W, 50W, 100W and one-channel, dual-channel, four-channel amplifiers to meet different requirements of customers. As a new member of class-D amplifier series, this 2*25W amplifier board employs TPA3123D2 chip from TI. It supports dual channel amplification and each such channel is rated at 25W which helps producing state-of-the-art sound quality. The efficiency of the TPA3123D2 eliminates the need for an external heat sink when playing music. Besides, integrating high-quality SMD and MKP plug-in capacitors ensures Hi-Fi amplification output. This amplifier can readily be powered by any DC power supply ranging from +10 to 30V. You can use it to drive any 4Ω or 8Ω passive speakers. It's an ideal choice for electronic hobbyists and audio enthusiasts.

FIGURE 1-1 PRODUCT DIAGRAM

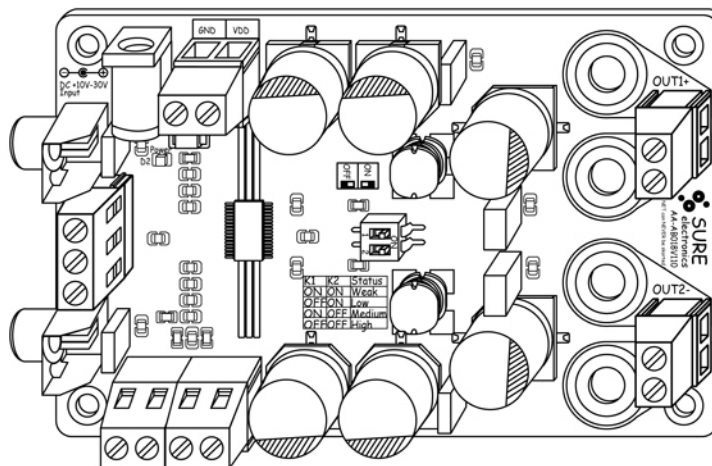

2*25W @4Ω TPA3123 Class-D Audio Amplifier Board

FIGURE 1-2 ACCESSORIES

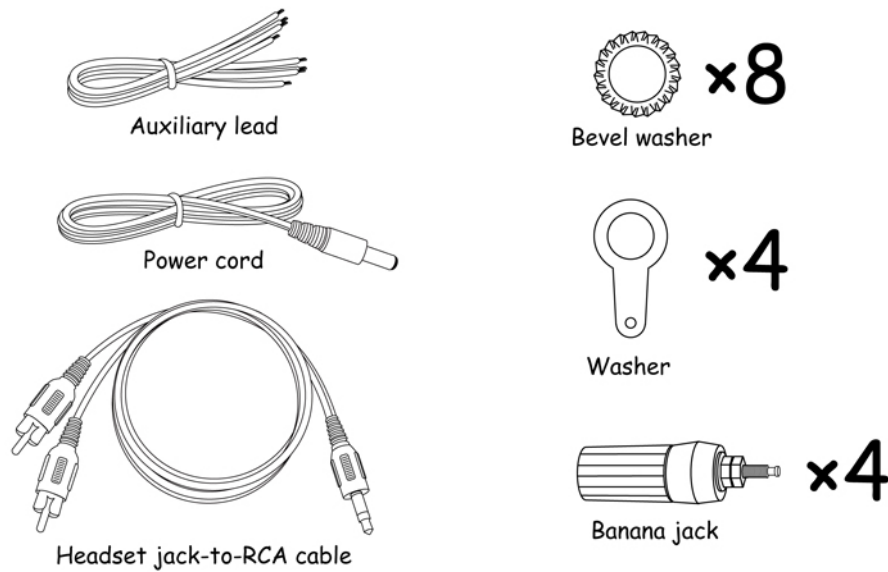

Note: The diagrams above are used for reference only.

1.2 Features

- A perfect "Class D" architecture
- Fully-bridged stereo output
- Wide power supply range: +10V-30V
- Two kinds of input: line level input and analog audio input
- Frequency response: 20Hz-20KHz(± 3 dB)
- Signal/Noise Ratio: 100dB(A-Weighted)
- High Output Power
 - 10W @ 8 Ω , < 10.0% THD+N
 - 25W @ 4 Ω , < 10.0% THD+N
- High Efficiency
 - 92% @ 8W 8 Ω
 - 85% @ 16W 4 Ω
- Audiophile Quality Sound
 - 0.08% THD+N @ 5W 8 Ω
 - 0.08% THD+N @ 10W 4 Ω
- Sensitivity and gain adjustable
- Over/under voltage turn off
- Over current protection
- Over temperature protection

1.3 Applications

- Active Subwoofers
- Home Theater Receiver
- Multi-channel Distribution
- Active DVD System
- Mini/Micro Systems

1.4 Benefits

- Mounting holes facilitate installation and fixing
- Several wiring methods facilitate connection
- Excellent design of the power ports which allows you to cascade multiple amplifier boards (max 4 recommended)
- Excellent heat dissipation eliminates the requirement of an extra heat sink

Note: Output signal cannot be bridged again.

1.5 Quick Start

Suggested connection is shown in figure 1-3.

FIGURE 1-3 CONNECTION SCHEMATIC

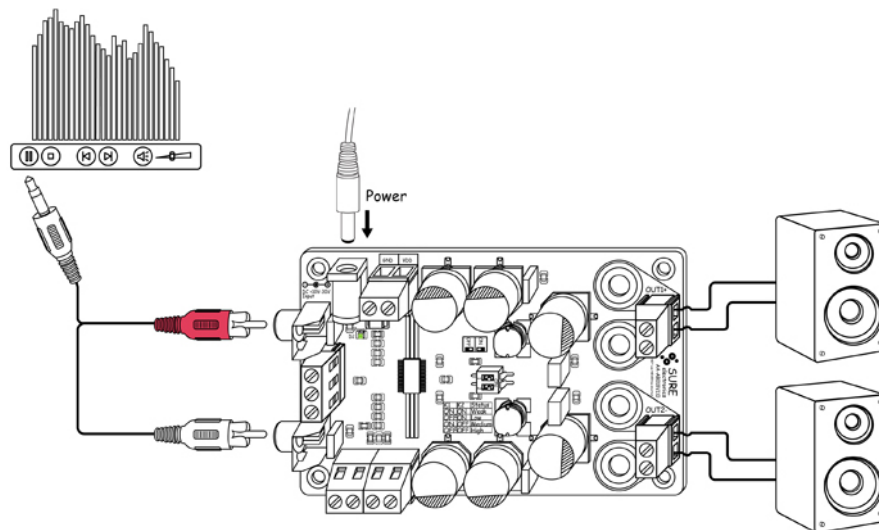

Note: Please observe the following steps to complete verification so as to ensure the products are intact during transit.

1. Open the amplifier package and make sure the product is intact (No missing or damaged components and no deformation)
2. Please observe the connection schematics when connecting the amplifier board. Use a nearby sound source, such as MP3 or CD player to have a trial. This amplifier board can be deemed as qualified if you can hear the sound corresponding to that sound source.

2*25W @4Ω TPA3123 Class-D Audio Amplifier Board

FIGURE 1-4 CASCADING SCHEMATIC

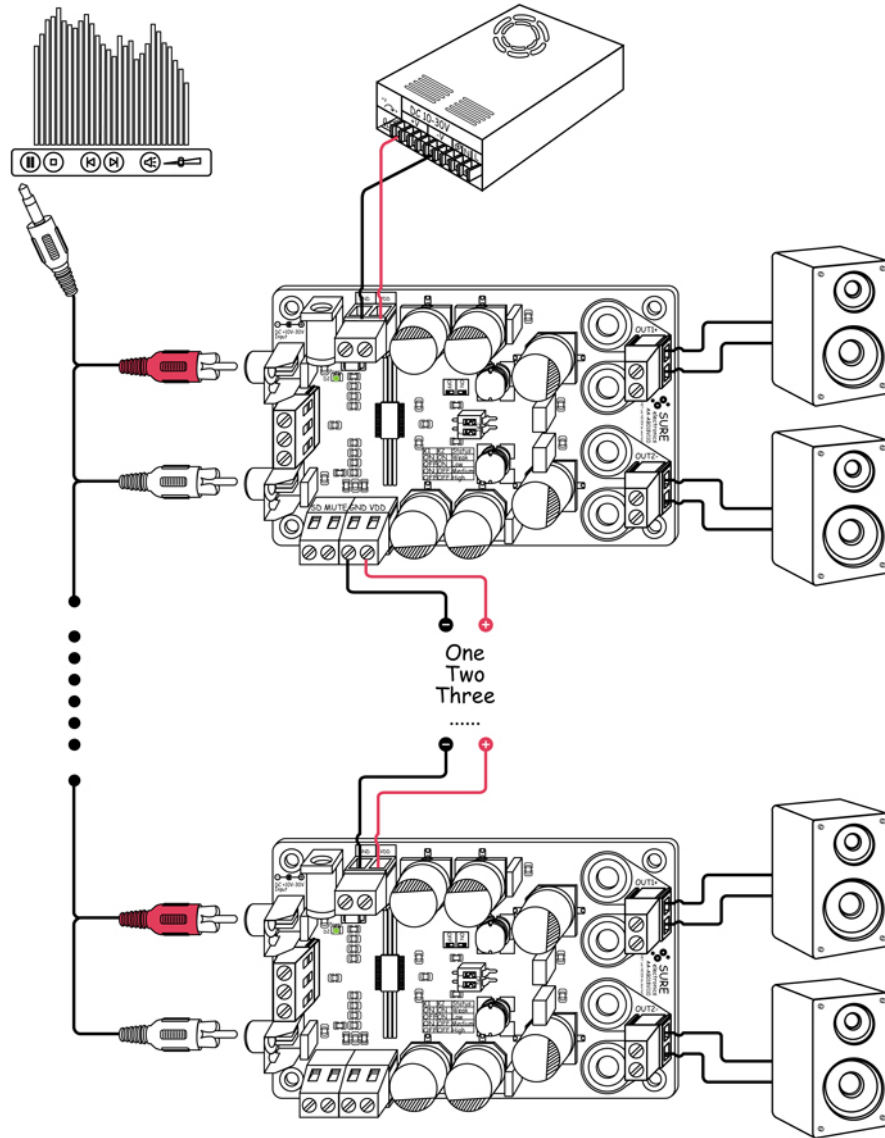

Note: GND should be grounded or connected to the housing of the device.

Chapter 2. Hardware Detail

2.1 Power Connection

To power the amplifier board, use either jack or terminal blocks. On-board diodes can prevent the consequence of wrong connection of power supply.

FIGURE 2-1 POWER CONNECTION

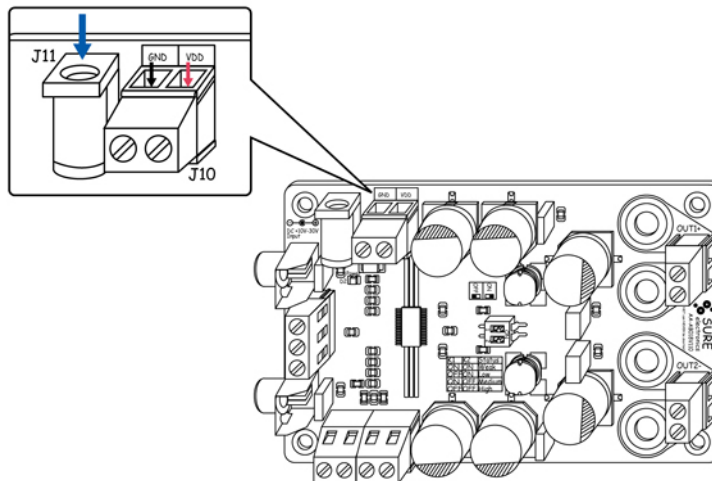

TABLE 2-1 POWER CONNECTION

Connector Mark		Description	
Jack	J11	DC 10-30V power supply	
Terminal Blocks	J10	VCC	The positive of DC 10-30V power supply
		GND	The negative of DC 10-30V power supply

Note:

1. You are allowed to use only one way to power the amplifier board at a time.
2. The maximum supply voltage shall not exceed 30V.

2.2 Input Connections

You may use RCA connectors to input audio signal.

2*25W @4Ω TPA3123 Class-D Audio Amplifier Board

FIGURE 2-2 INPUT CONNECTION

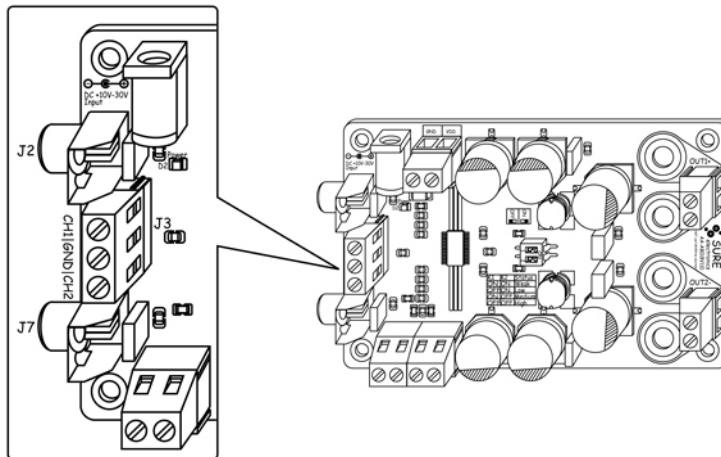

TABLE 2-2 INPUT CONNECTION

Connector Mark		Channel Description
RCA connector	J2	Channel 1 Input
	J7	Channel 2 Input
Terminal Blocks	J3 (PIN 1)	Channel 1 Input
	J3 (PIN 2)	GND
	J3 (PIN 3)	Channel 2 Input

Note: You are allowed to feed only one group (dual channel) of audio signal to the amplifier board at a time. Please refer to 2.6 “Gain Setting” for details.

2.3 Output Connections

You can use either terminal blocks or banana connectors to output audio signal. Two pairs of banana jacks are provided for free.

FIGURE 2-3 OUTPUT CONNECTION 1

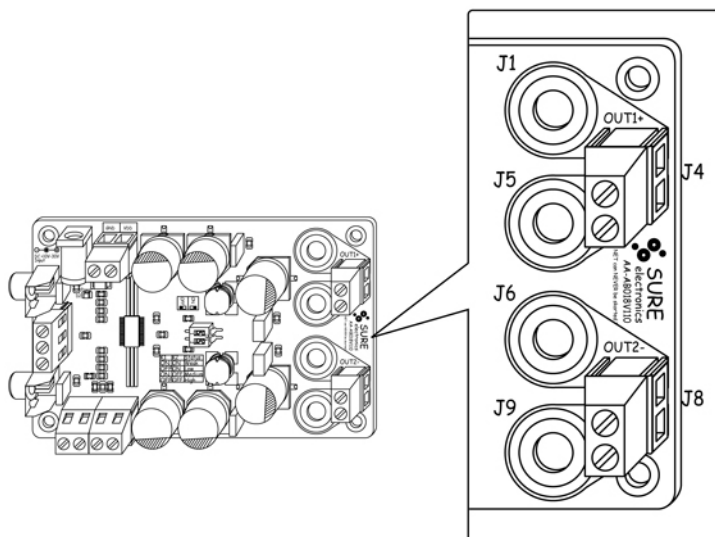
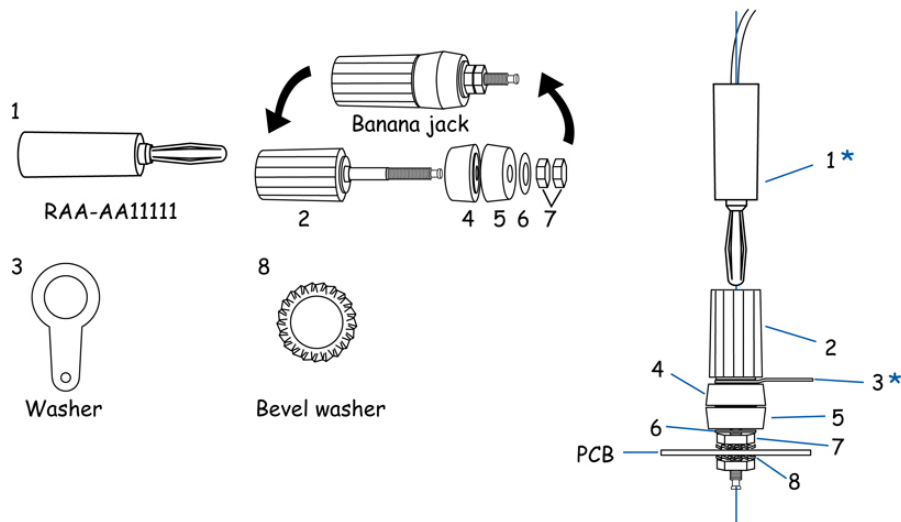

FIGURE 2-4 OUTPUT CONNECTION 2



Note:

1*: not provided here. It can be used together with banana jack ("2" above) facilitating wiring. You can click <http://www.sureelectronics.net/goods.php?id=1036> for details.

3*: included in the accessories but selectable to be installed.

TABLE 2-3 OUTPUT CONNECTION

Connector Mark		Description
Banana Connectors	J1	Positive Output of Channel 1
	J5	Negative Output of Channel 1
	J6	Negative Output of Channel 2
	J9	Positive Output of Channel 2
Terminal blocks Refer to on-board descriptions for connection details	J4	Output of Channel 1
	J8	Output of Channel 2

Note: Never connect more than one group of speaker to the audio output.

2.4 Connection with Next Board

J10 and J12 on terminal blocks are used to connect more amplifier boards.

FIGURE 2-5 CONNECTION SCHEMATIC

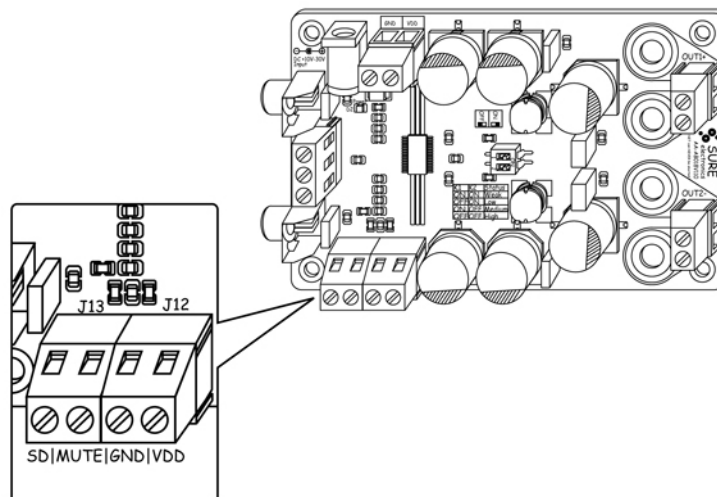

2*25W @4Ω TPA3123 Class-D Audio Amplifier Board

TABLE 2-4 CONNECTION WITH NEXT BOARD

Connector Mark		Description
J12	VDD	Connect to Positive (+) of DC 10 to 36V Power Supply (J10) of the next board
	GND	Connect to Negative (GND) of DC 10 to 36V Power Supply (J10) of the next board
J13	SD	Sleep Control
	MUTE	Mute Control

Note:

1. Maximum 4 amplifiers are recommended to be connected in series.
2. Remember to use AWG12-compliant cable or equivalent for series connection.

2.5 Mute Settings

To mute the output audio signal, connect “VDD” and “MUTE” of the terminal block with a piece of lead. Usually, “MUTE” shall be left unconnected.

FIGURE 2-6 MUTE SETTINGS

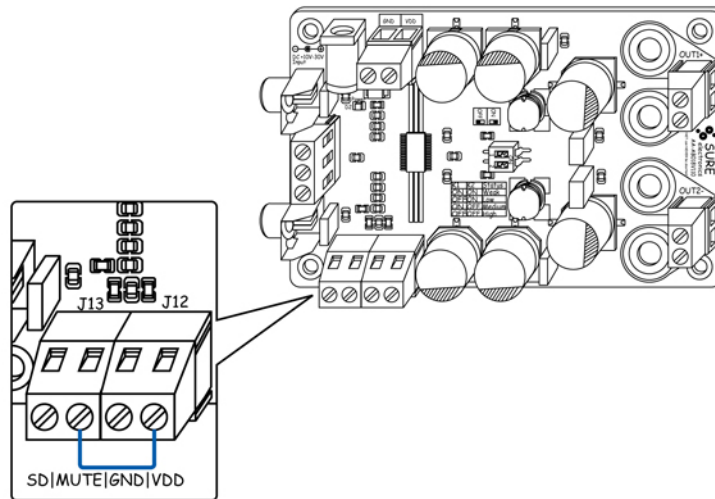

TABLE 2-5 MUTE SETTINGS

Connector Mark		Description
J13	MUTE	When “MUTE” is connected with “VDD”, both channels will be muted and enter into idle mode. When connected to ground or left unconnected, both channels will resume regular operation.

Note: Please power the amplifier board with DC 10-30V.

2.6 Sleep Settings

To enable sleep setting, connect “VDD” and “SD” of the terminal block with a piece of lead. Usually, “SD” shall be left unconnected.

FIGURE 2-7 SLEEP SETTINGS

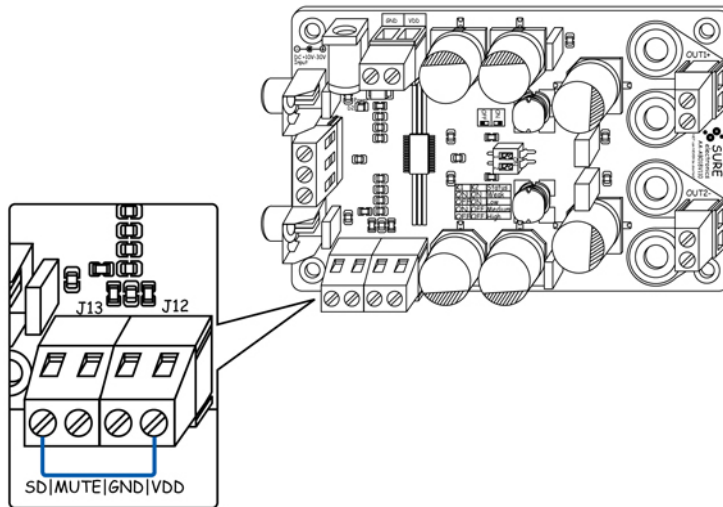

TABLE 2-6 SLEEP SETTINGS

Connector Mark		Description
J13	SD	When “SD” is connected with “VDD”, both channels will be set to SLEEP and enter low-power-consumption working mode. When connected to ground or left unconnected, both channels will resume regular operation.

Note: “SD” means that the chip works with low power consumption. “MUTE” means that the chip normally works with no output.

2.7 Gain Settings

The on-board 2-slide DIP switch, which is marked as “SW1”, is used to set the gain of amplifier board. The two slides are marked as K1, K2 respectively. The following table lists the gain values on different settings:

2*25W @4Ω TPA3123 Class-D Audio Amplifier Board

FIGURE 2-8 GAIN SETTINGS

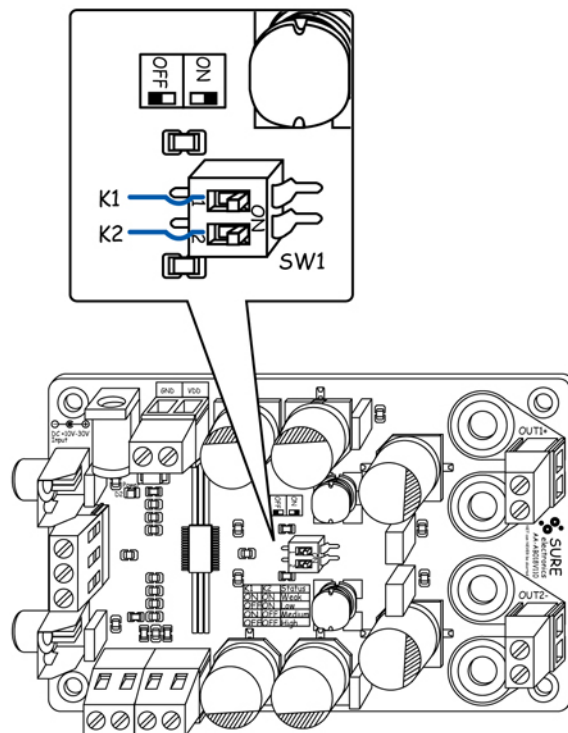

TABLE 2-7 GAIN SETTINGS

Settings		Amplification Gain	
K1	K2	Gain Level	Power Gain (dB) Typical
ON	ON	Weak	20
OFF	ON	Low	26
ON	OFF	Medium	32
OFF	OFF	High	36

Note:

1. High: Portable MP3/CD player with built-in volume control
Medium and low: General-purpose use
Weak: Preamplifier with fairly high output signal
2. Different gain levels correspond to different input sensitivities. Improper selection will cause the audio distortion or even damage the amplifier board.
3. No preamplifier or other devices are needed for gain settings. We won't assume any responsibility for the damage caused by connecting extra devices.

2.8 DC Offset

Capacitive coupling output is applied to ensure no DC offset output.

2.9 LED Indicators

This amplifier has one power LED indicator which is marked as "Power (D2)". The power indicator will be illuminated in green when power-up. Please refer to the connection schematics of the board for the LED location.

FIGURE 2-9 LED INDICATOR

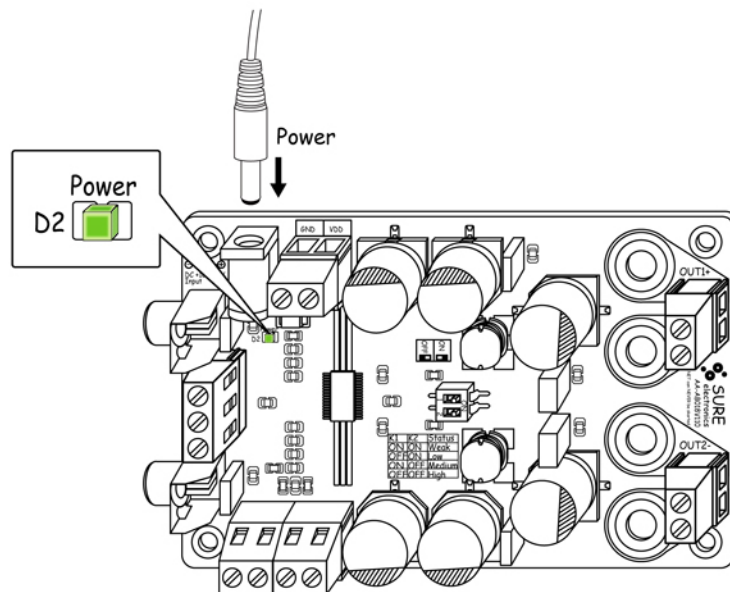

2.10 Volume Control

No potentiometer is provided for manually adjusting the volume. The volume control of sound source like MP3 player or PC can be used to adjust the loudness of the audio output or a 50K Ω potentiometer can be installed by users themselves, but it may cause signal attenuation. To compensate that attenuation, adjusting the gain value is required. You may refer to 2.7 Gain setting for details.

Please be aware that audio clippings may occur to some portable players because of the audio source not the amplifier itself. Please increase the input gain of amplifier board.

2.11 Notes

In order to protect amplifier board and extend its service lifetime, please read the following warnings carefully since warranties will be voided if you do not observe the following warnings:

Warning 1:

Quality-related issues caused by potentiometers installed by buyers.

Warning 2:

In order to achieve a better sound quality, please use stable power supply since a bad or unstable power supply may worsen the sound quality or even cripple the amplifier board.

Warning 3:

Never equip a pre-amplifier to the audio input since the amplifier itself has powerful amplification ability and a high signal input will burn out the amplifier chip.

Warning 4:

In order to protect amplifier and speaker, please turn the volume output to the minimum when hooking up the amplifier and you may readjust the volume when you are sure that the amplifier is functioning properly.

Chapter 3. Electrical Characteristics

Following table lists all typical data. For full specification, please refer to the TI data sheet of TPA3123 chip.

$T_A=20^{\circ}\text{C}$, DC24V, $f=1000\text{Hz}$, Sine wave input, $R_L=4\Omega$, Gain=20dB (unless otherwise stated)

TABLE 3-1 ELECTRICAL CHARACTERISTICS

Parameter		Condition	Min.	Typ.	Max.
Supply Voltage		-	10V	-	30V
Supply Current		-	-	-	2A
Signal/Noise Ratio		-	90dB	100dB	-
Input Sensitivity	Gain=36dB	-	0.100V	0.117V	-
	Gain=32dB	-	0.180V	0.196V	-
	Gain=28dB	-	0.380V	0.396V	-
	Gain=20dB	-	0.780V	0.803V	-
THD+N*		$V_{DD}=24\text{V}$, $R_L=4\Omega$, $P_{out}=10\text{W}$	-	0.08%	-
		$V_{DD}=24\text{V}$, $R_L=8\Omega$, $P_{out}=5\text{W}$	-	0.08%	-
Frequency Range		-	20Hz-20KHz ($\pm 3\text{dB}$)		
Efficiency		$V_{DD}=24\text{V}$, $R_L=4\Omega$, $P_{out}=16\text{W}$	-	85%	-
		$V_{DD}=24\text{V}$, $R_L=8\Omega$, $P_{out}=8\text{W}$	-	92%	-
Output Power	THD+N<1%	$V_{DD}=24\text{V}$, $R_L=4\Omega$, $f=1000\text{Hz}$	-	16W	-
		$V_{DD}=24\text{V}$, $R_L=8\Omega$, $f=1000\text{Hz}$	-	8W	-
	THD+N<10%	$V_{DD}=24\text{V}$, $R_L=4\Omega$, $f=1000\text{Hz}$	-	20W	-
		$V_{DD}=24\text{V}$, $R_L=8\Omega$, $f=1000\text{Hz}$	-	10W	-
Input Impedance		-	-	60K	-
Minimum Load		-	3.2Ω	-	-
SD, MUTE*	High-level input voltage	-	2V	-	-
	Low-level	-	-	-	0.8V

2*25W@4Ω TPA3123 Class-D Audio Amplifier Board

	Input voltage						
Channel Separation*		-			-50dB	-60dB	-
Power Gain*	SW1	-	K1	K2	-	-	-
	Weak	-	ON	ON	18 dB	20 dB	22 dB
	Low	-	OFF	ON	24 dB	26 dB	28 dB
	Medium	-	ON	OFF	30 dB	32 dB	34 dB
	High	-	OFF	OFF	34 dB	36 dB	38 dB
Operating Temperature		-			0°C	20°C	50°C
Storage Temperature		-			-20°C	20°C	105°C
Thermal Shutdown*		-			-	150°C	-

Note: *The chip specifications from TI's TPA3123 Data Sheet.

Chapter 4. Mechanical Drawing

FIGURE 4-1 MECHANICAL DRAWING

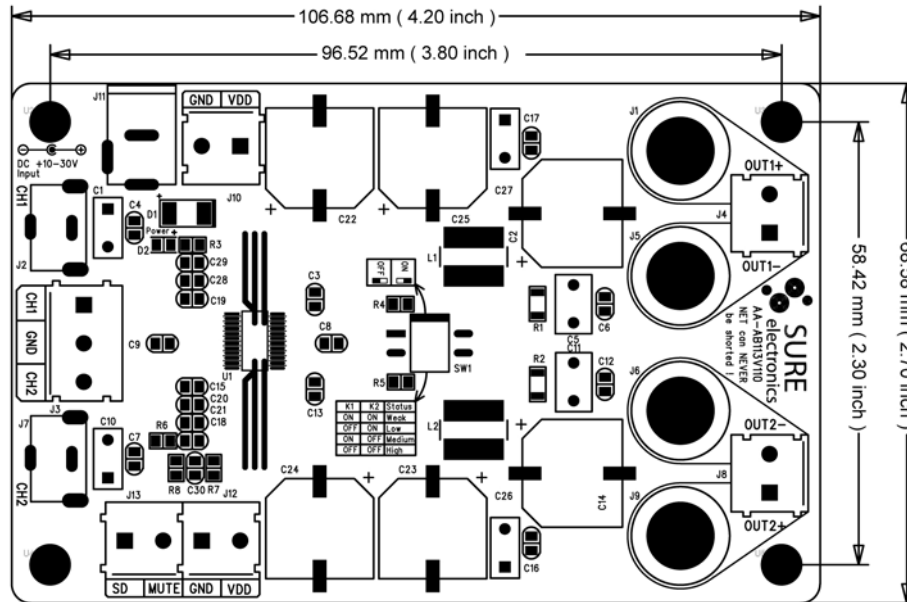

Chapter 5. Appendix

FIGURE 5-1 SCHEMATIC

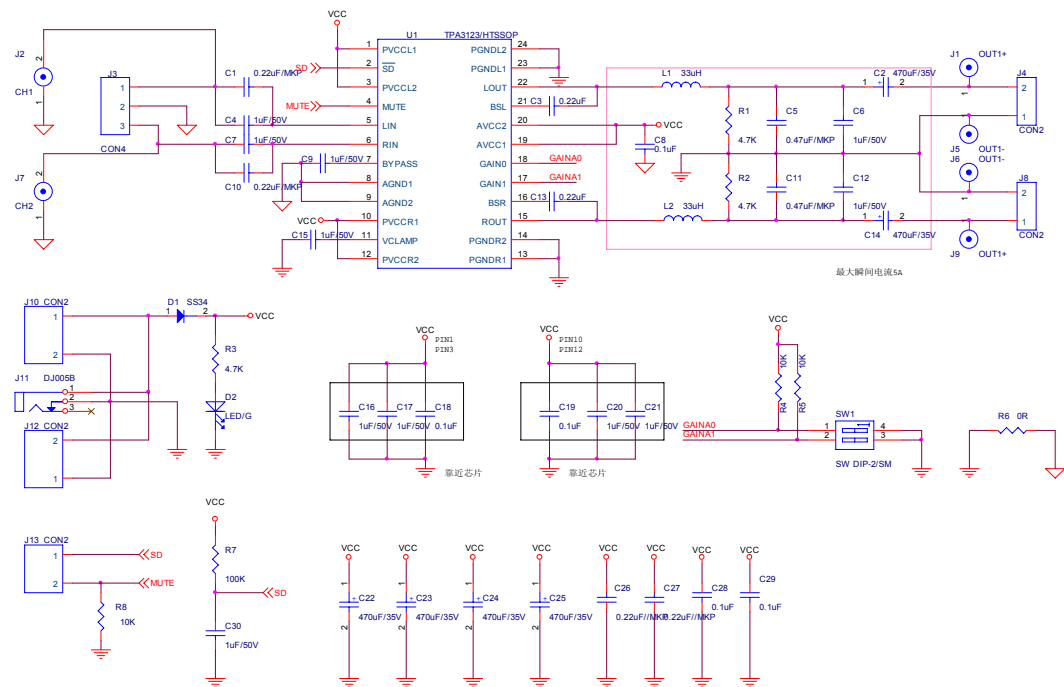

Note: The above schematic is used for reference only. There might be a tiny difference in production batch.



2*25W @4Ω TPA3123 CLASS-D AUDIO AMPLIFIER BOARD USER'S GUIDE

Chapter 6. Contact Us

Sure Electronics Co., Ltd.

5F, Zone A,
Qinhuai Technology Innovation Center
105-2 DaMing Rd (ZIP:210022)
Nanjing
P.R.China

Tel: +86-13601408832 (For technical questions only)
+86-25-66606340 (English service, from GMT1-10AM)
Fax: +86-25- 66606341-866
Website: www.sure-electronics.com
www.sure-electronics.net