

# TPA3126D2 50-W Stereo, Analog-Input, Class-D Audio Amplifier with Low, 15-mA Idle Current and AM Avoidance

## 1 Features

- Longer Battery-Operating Time:
  - Ultra-Low Idle Current: 15 mA at 12 V
- 2 × 50 W Into a 4-Ω Load at 21 V, 10% THD+N
- Wide Voltage Range: 4.5 V to 26 V
- Highly Efficient Class-D Operation
  - Hybrid Modulation Scheme Dynamically Reduces Power Loss
  - Low  $R_{ds(on)}$  of 90-mΩ Enables > 90% Efficiency
- Pop-and-Click Noise Suppression
- Supports Stereo, Mono BTL and Mono PBTL
- Multiple Switching Frequencies:
  - AM Avoidance
  - Master and Slave Synchronization
  - 300-KHz to 1.2-MHz Switching Frequencies
- Selectable Gains: 20 dB, 26 dB, 32 dB, 36 dB
- Programmable Power Limit
- Supports Both Single and Dual Power Supply
- Integrated Protections with Error Report:
  - Overvoltage, Undervoltage, Overtemperature, DC-Detect, and Short Circuit
- Thermally Enhanced Package
  - DAD (32-Pin HTSSOP PowerPAD™ Up)
- Performance Upgrade of the TPA3116D2
  - 70% Less Idle Current; Pin-to-Pin Compatible

## 2 Applications

- Speaker Docks
- Bluetooth® and Wi-Fi Speakers
- Voice Operated Speakers or Smart Speakers
- Sound Bars
- Bookshelf Stereo System

## 3 Description

The TPA3126D2 is a 50-W, stereo, low-idle-current Class-D amplifier in a thermally enhanced package. The TPA3126D2 includes TI's proprietary hybrid modulation scheme, which dynamically reduces idle current at low power levels to extend the battery life of portable audio systems, like bluetooth speakers.

To further simplify the design, the Class-D amplifier integrates full protection features including short circuit, thermal shutdown, overvoltage, undervoltage, and DC speaker protection. Faults are reported back to the processor to prevent devices from being damaged during overload conditions.

### Device Information<sup>(1)</sup>

PART NUMBER	PACKAGE	BODY SIZE (NOM)
TPA3126D2	HTSSOP (32)	11.00 mm × 6.20 mm

(1) For all available packages, see the orderable addendum at the end of the data sheet.

TPA3126 and TPA3116 Idle Current

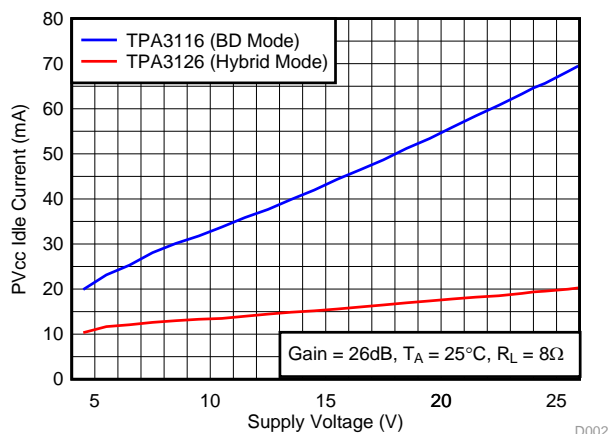

Simplified Application Circuit

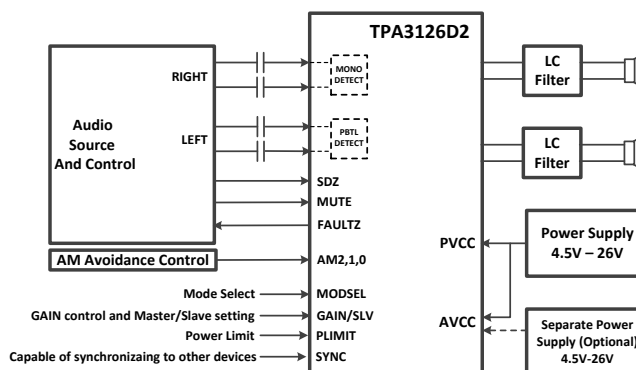

## Table of Contents

<b>1 Features</b> .....	<b>1</b>	8.4 Device Functional Modes.....	<b>22</b>
<b>2 Applications</b> .....	<b>1</b>	<b>9 Application and Implementation</b> .....	<b>24</b>
<b>3 Description</b> .....	<b>1</b>	9.1 Application Information.....	<b>24</b>
<b>4 Revision History</b> .....	<b>2</b>	<b>10 Power Supply Recommendations</b> .....	<b>26</b>
<b>5 Device Comparison Table</b> .....	<b>3</b>	10.1 Power Supply Mode.....	<b>26</b>
<b>6 Pin Configuration and Functions</b> .....	<b>4</b>	<b>11 Layout</b> .....	<b>27</b>
<b>7 Specifications</b> .....	<b>6</b>	11.1 Layout Guidelines .....	<b>27</b>
7.1 Absolute Maximum Ratings .....	<b>6</b>	11.2 Layout Example .....	<b>28</b>
7.2 ESD Ratings .....	<b>6</b>	11.3 Heat Sink Used on the EVM.....	<b>30</b>
7.3 Recommended Operating Conditions.....	<b>6</b>	<b>12 Device and Documentation Support</b> .....	<b>31</b>
7.4 Thermal Information .....	<b>7</b>	12.1 Device Support .....	<b>31</b>
7.5 DC Electrical Characteristics .....	<b>7</b>	12.2 Receiving Notification of Documentation Updates	<b>31</b>
7.6 AC Electrical Characteristics.....	<b>8</b>	12.3 Related Documentation.....	<b>31</b>
7.7 Typical Characteristics.....	<b>9</b>	12.4 Community Resources.....	<b>31</b>
<b>8 Detailed Description</b> .....	<b>13</b>	12.5 Trademarks .....	<b>31</b>
8.1 Overview .....	<b>13</b>	12.6 Electrostatic Discharge Caution.....	<b>31</b>
8.2 Functional Block Diagram .....	<b>13</b>	12.7 Glossary .....	<b>31</b>
8.3 Feature Description.....	<b>14</b>	<b>13 Mechanical, Packaging, and Orderable Information</b> .....	<b>31</b>

## 4 Revision History

DATE	REVISION	NOTES
April 2018	*	Initial release.

## 5 Device Comparison Table

PRODUCT	DESCRIPTION	MODULATION SCHEME	THERMAL PAD LOCATION	TPA3126 PIN-COMPATIBLE
<a href="#">TPA3116D2</a>	50-W Stereo, Analog-Input Class D Amplifier	BD, 1SPW	Top	Y
<a href="#">TPA3118D2</a>	30-W Stereo, Analog-Input Class D Amplifier	BD, 1SPW	Bottom	Y
<a href="#">TPA3128D2</a>	30-W Stereo, Analog-Input Class D Amplifier with Low Idle Power Dissipation	BD, 1SPW, Hybrid	Bottom	Y
<a href="#">TPA3156D2</a>	70-W Stereo, Analog-Input Class D Amplifier with Low Idle Power Dissipation	BD, 1SPW, Hybrid	Top	Y

## 6 Pin Configuration and Functions

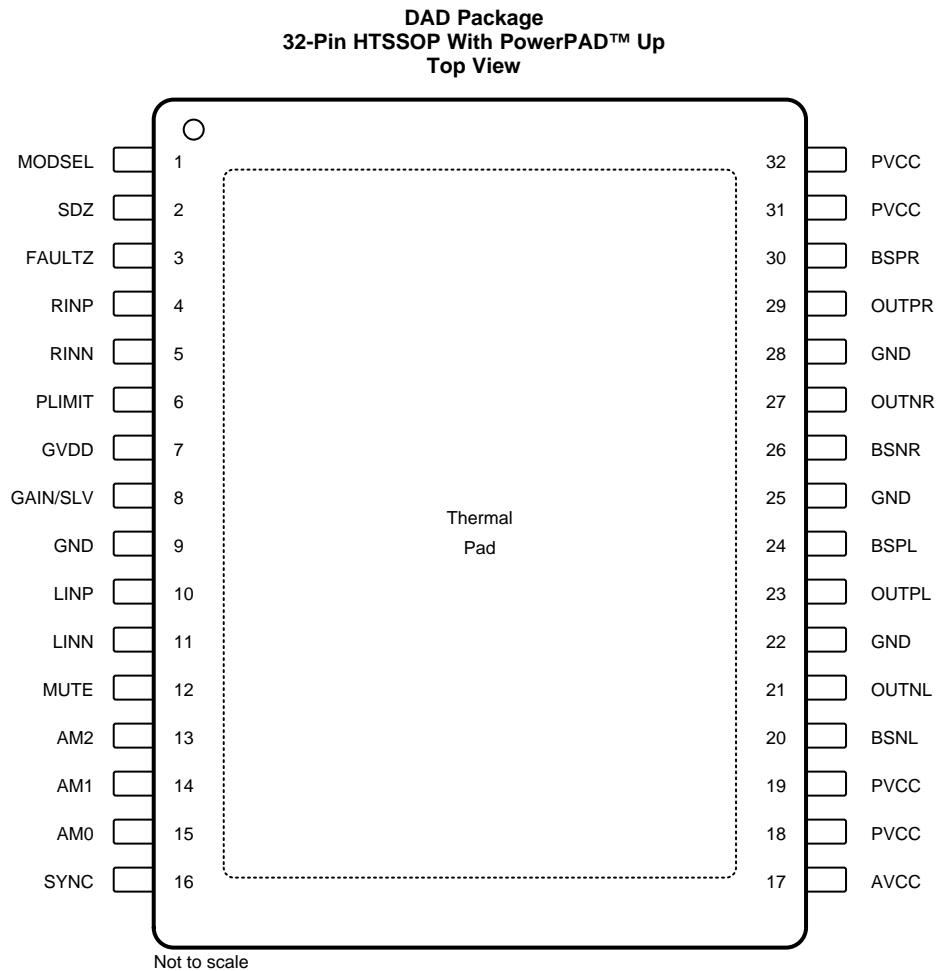

### Pin Functions

PIN		TYPE <sup>(1)</sup>	DESCRIPTION
NO.	NAME		
1	MODSEL	I	Mode selection logic input (LOW = Hybrid Mode, HIGH = BD Mode). TTL logic levels with compliance to AVCC. Refer to: <a href="#">Device Modulation Scheme</a>
2	SDZ	I	Shutdown logic input for audio amp (LOW = outputs Hi-Z, HIGH = outputs enabled). TTL logic levels with compliance to AVCC. Refer to: <a href="#">Startup and Shutdown Operation</a>
3	FAULTZ	DO	General fault reporting including Over-temp, DC Detect. Open drain. Refer to: <a href="#">Device Protection System</a> FAULTZ = High, normal operation FAULTZ = Low (an external 100 kΩ pull-up resistor required), fault condition
4	RINP	I	Positive audio input for right channel. Connect to GND for MONO mode.
5	RINN	I	Negative audio input for right channel. Connect to GND for MONO mode.
6	PLIMIT	I	Power limit level adjust. Connect a resistor divider from GVDD to GND to set power limit. Connect directly to GVDD for no power limit. Refer to: <a href="#">PLIMIT Operation</a>
7	GVDD	PO	Internally generated gate voltage supply. Not to be used as a supply or connected to any component other than a 1 μF X7R ceramic decoupling capacitor and the PLIMIT and GAIN/SLV resistor dividers. Refer to: <a href="#">GVDD Supply</a>
8	GAIN/SLV	I	Selects Gain and selects between Master and Slave mode depending on pin voltage divider. Refer to: <a href="#">Gain Setting and Master and Slave</a>
9	GND	G	Ground

(1) DO = Digital Output, I = Analog Input, G = General Ground, PO = Power Output, BST = Boot Strap.

**Pin Functions (continued)**

PIN		TYPE <sup>(1)</sup>	DESCRIPTION
NO.	NAME		
10	LINP	I	Positive audio input for left channel. Connect to GND for PBTL mode.
11	LINN	I	Negative audio input for left channel. Connect to GND for PBTL mode.
12	MUTE	I	Mute signal for fast disable/enable of outputs (HIGH = outputs Hi-Z, LOW = outputs enabled). TTL logic levels with compliance to AVCC.
13	AM2	I	AM Avoidance Frequency Selection
14	AM1	I	AM Avoidance Frequency Selection
15	AM0	I	AM Avoidance Frequency Selection
16	SYNC	DIO	Clock input/output for synchronizing multiple Class-D devices. Direction determined by GAIN/SLV terminal. Refer to: <a href="#">Gain Setting and Master and Slave</a>
17	AVCC	P	Analog Supply
18	PVCC	P	Power supply
19	PVCC	P	Power supply
20	BSNL	BST	Boot strap for negative left channel output, connect to 220 nF X5R, or better ceramic cap to OUTPL
21	OUTNL	PO	Negative left channel output
22	GND	G	Ground
23	OUTPL	PO	Positive left channel output
24	BSPL	BST	Boot strap for positive left channel output, connect to 220 nF X5R, or better ceramic cap to OUTNL Refer to: <a href="#">BSPx and BSNx Capacitors</a>
25	GND	G	Ground
26	BSNR	BST	Boot strap for negative right channel output, connect to 220 nF X5R, or better ceramic cap to OUTNR. Refer to: <a href="#">BSPx and BSNx Capacitors</a>
27	OUTNR	PO	Negative right channel output
28	GND	G	Ground
29	OUTPR	PO	Positive right channel output
30	BSPR	BST	Boot strap for positive right channel output, connect to 220 nF X5R or better ceramic cap to OUTPR. Refer to: <a href="#">BSPx and BSNx Capacitors</a>
31	PVCC	P	Power supply
32	PVCC	P	Power supply
	PowerPAD™	G	Connect to GND for best system performance. If not connected to GND, leave floating.

## 7 Specifications

### 7.1 Absolute Maximum Ratings

over operating free-air temperature range (unless otherwise noted)<sup>(1)</sup>

		MIN	MAX	UNIT
Supply voltage, $V_{CC}$	$PV_{CC}, AV_{CC}$	-0.3	30	V
Input voltage, $V_I$	INPL, INNL, INPR, INNRR	-0.3	6.3	V
	PLIMIT, GAIN/SLV, SYNC	-0.3	GVDD+0.3	V
	AM0, AM1, AM2, MUTE, SDZ, MODSEL	-0.3	PVCC+0.3	V
Slew rate, maximum <sup>(2)</sup>	AM0, AM1, AM2, MUTE, SDZ, MODSEL		10	V/ms
Operating free-air temperature, $T_A$		-40	85	°C
Operating junction temperature, $T_J$		-40	150	°C
Storage temperature, $T_{stg}$		-40	125	°C

- (1) Stresses beyond those listed under absolute maximum ratings can cause permanent damage to the device. These are stress ratings only, and functional operation of the device at these or any other conditions beyond those indicated under recommended operating conditions is not implied. Exposure to absolute-maximum-rated conditions for extended periods can affect device reliability.
- (2) 100-k $\Omega$  series resistor is required if maximum slew rate is exceeded.

### 7.2 ESD Ratings

		VALUE	UNIT
$V_{(ESD)}$ Electrostatic discharge	Human-body model (HBM), per ANSI/ESDA/JEDEC JS-001 <sup>(1)</sup>	$\pm 2000$	V
	Charged-device model (CDM), per JEDEC specification JESD22-C101 <sup>(2)</sup>	$\pm 500$	

(1) JEDEC document JEP155 states that 500-V HBM allows safe manufacturing with a standard ESD control process.

(2) JEDEC document JEP157 states that 250-V CDM allows safe manufacturing with a standard ESD control process.

### 7.3 Recommended Operating Conditions

over operating free-air temperature range (unless otherwise noted)

		MIN	NOM	MAX	UNIT
$V_{CC}$	Supply voltage	$PV_{CC}, AV_{CC}$	4.5	26	V
$V_{IH}$	High-level input voltage	AM0, AM1, AM2, MUTE, SDZ, SYNC, MODSEL	2		V
$V_{IL}$	Low-level input voltage	AM0, AM1, AM2, MUTE, SDZ, SYNC, MODSEL		0.8	V
$V_{OL}$	Low-level output voltage	FAULTZ, $R_{PULL-UP} = 100\text{ k}\Omega$ , $PV_{CC} = 26\text{ V}$		0.8	V
$I_{IH}$	High-level input current	AM0, AM1, AM2, MUTE, SDZ, MODSEL ( $V_I = 2\text{ V}$ , $V_{CC} = 18\text{ V}$ )		50	$\mu\text{A}$
$R_L(\text{BTL})$	Minimum load Impedance	Output filter: $L = 10\text{ }\mu\text{H}$ , $C = 680\text{ nF}$	3.2	4	$\Omega$
$R_L(\text{PBTL})$		Output filter: $L = 10\text{ }\mu\text{H}$ , $C = 1\text{ }\mu\text{F}$	1.6	2	
$L_o$	Output-filter Inductance	Minimum output filter inductance under short-circuit condition	1		$\mu\text{H}$

## 7.4 Thermal Information

THERMAL METRIC <sup>(1)</sup>		TPA3126D2	
		DAD <sup>(2)</sup>	
		32 PINS	
			UNIT
$R_{\theta JA}$	Junction-to-ambient thermal resistance	N/A	°C/W
$R_{\theta JC(top)}$	Junction-to-case (top) thermal resistance	1.2	°C/W
$\Psi_{JT}$	Junction-to-top characterization parameter	1.2	°C/W
$\Psi_{JB}$	Junction-to-board characterization parameter	21	°C/W

- (1) For more information about traditional and new thermal metrics, see the [Semiconductor and IC Package Thermal Metrics](#) application report.
- (2) For the PCB layout, see the [TPA3126D2EVM](#) user guide.

## 7.5 DC Electrical Characteristics

 $T_A = 25^\circ\text{C}$ ,  $AV_{CC} = PV_{CC} = 12\text{ V to }24\text{ V}$ ,  $R_L = 4\ \Omega$ ,  $f_s = 400\text{ kHz}$ , hybrid mode (unless otherwise noted)

PARAMETER		TEST CONDITIONS	MIN	TYP	MAX	UNIT
$ V_{OS} $	Class-D output offset voltage (measured differentially)	$V_I = 0\text{ V}$		1.5	5	mV
$I_{CC}$	Quiescent supply current	SDZ = 2 V, With load and filter, $PV_{CC} = 12\text{ V}$ SDZ = 2 V, With load and filter, $PV_{CC} = 24\text{ V}$		15 23		mA
$I_{CC(SD)}$	Quiescent supply current in shutdown mode	SDZ = 0.8 V, With load and filter, $PV_{CC} = 12\text{ V}$ SDZ = 0.8 V, With load and filter, $PV_{CC} = 24\text{ V}$		20 30		$\mu\text{A}$
$r_{DS(on)}$	Drain-source on-state resistance, measured pin to pin	$PV_{CC} = 21\text{ V}$ , $I_{out} = 500\text{ mA}$ , $T_J = 25^\circ\text{C}$		90		m $\Omega$
G	Gain (BTL)	R1 = 5.6 k $\Omega$ , R2 = Open	19	20	21	dB
		R1 = 20 k $\Omega$ , R2 = 100 k $\Omega$	25	26	27	
		R1 = 39 k $\Omega$ , R2 = 100 k $\Omega$	31	32	33	dB
		R1 = 47 k $\Omega$ , R2 = 75 k $\Omega$	35	36	37	
G	Gain (SLV)	R1 = 51 k $\Omega$ , R2 = 51 k $\Omega$	19	20	21	dB
		R1 = 75 k $\Omega$ , R2 = 47 k $\Omega$	25	26	27	
		R1 = 100 k $\Omega$ , R2 = 39 k $\Omega$	31	32	33	dB
		R1 = 100 k $\Omega$ , R2 = 16 k $\Omega$	35	36	37	
$t_{on}$	Turn-on time	SDZ = 2 V		40		ms
$t_{OFF}$	Turn-off time	SDZ = 0.8 V		2		$\mu\text{s}$
GVDD	Gate drive supply	$I_{GVDD} < 200\ \mu\text{A}$	5.1	5.6	6.3	V
$V_O$	Output voltage maximum under PLIMIT control	$V_{(PLIMIT)} = 2\text{ V}$ ; $V_I = 1\text{ V}_{rms}$	6.75	8.2	8.75	V

## 7.6 AC Electrical Characteristics

 $T_A = 25^\circ\text{C}$ ,  $AV_{CC} = PV_{CC} = 12\text{ V to }24\text{ V}$ ,  $R_L = 4\ \Omega$  (unless otherwise noted)

PARAMETER		TEST CONDITIONS	MIN	TYP	MAX	UNIT
KSVR	Power supply ripple rejection	200 mV <sub>PP</sub> ripple at 1 kHz, Gain = 26 dB, Inputs AC-coupled to GND		-70		dB
P <sub>O</sub>	Continuous output power	THD+N = 10%, f = 1 kHz, PV <sub>CC</sub> = 14.4 V		25		W
		THD+N = 10%, f = 1 kHz, PV <sub>CC</sub> = 21 V		50		
THD+N	Total harmonic distortion + noise	V <sub>CC</sub> = 21 V, f = 1 kHz, P <sub>O</sub> = 15 W (half-power)		0.1%		
V <sub>n</sub>	Output integrated noise	20 Hz to 22 kHz, A-weighted filter, Gain = 20 dB		65		μV
				-80		dBV
	Crosstalk	V <sub>O</sub> = 1 V <sub>rms</sub> , Gain = 20 dB, f = 1 kHz		-100		dB
SNR	Signal-to-noise ratio	Maximum output at THD+N < 1%, f = 1 kHz, Gain = 20 dB, A-weighted		102		dB
f <sub>OSC</sub>	Oscillator frequency	AM2=0, AM1=0, AM0=0	376	400	424	kHz
		AM2=0, AM1=0, AM0=1	470	500	530	
		AM2=0, AM1=1, AM0=0	564	600	636	
		AM2=0, AM1=1, AM0=1	940	1000	1060	
		AM2=1, AM1=0, AM0=0	1128	1200	1278	
		AM2=1, AM1=0, AM0=1	282	300	318	
		AM2=1, AM1=1, AM0=0 Modulation scheme Fixed in 1SPW Mode	282	300	318	
		AM2=1, AM1=1, AM0=1, Reserved				
	Thermal trip point		≥150		°C	
	Thermal hysteresis		15		°C	
	Over current trip point		7.5		A	



### 7.7 Typical Characteristics

$f_s = 400$  kHz, Hybrid Mode, TPA3126D2EVM Tested With AP2722. (unless otherwise noted)

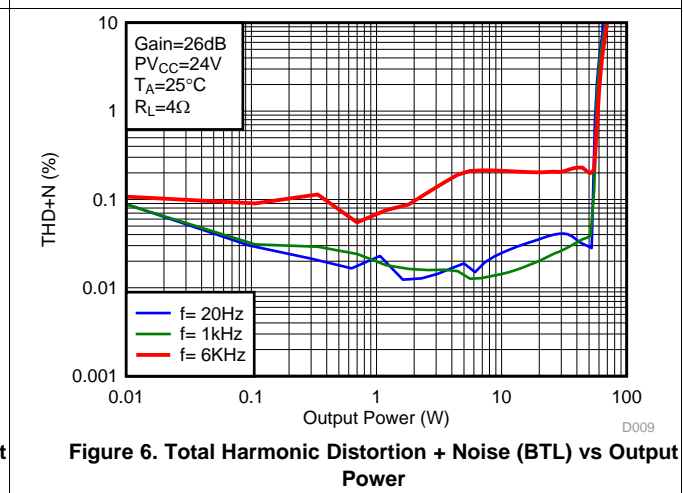
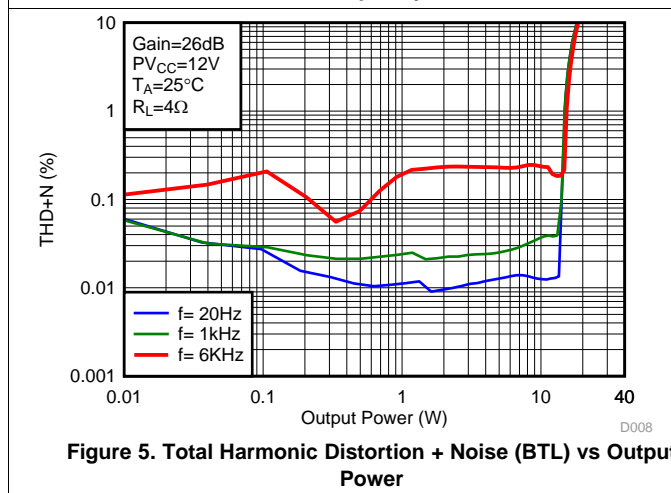
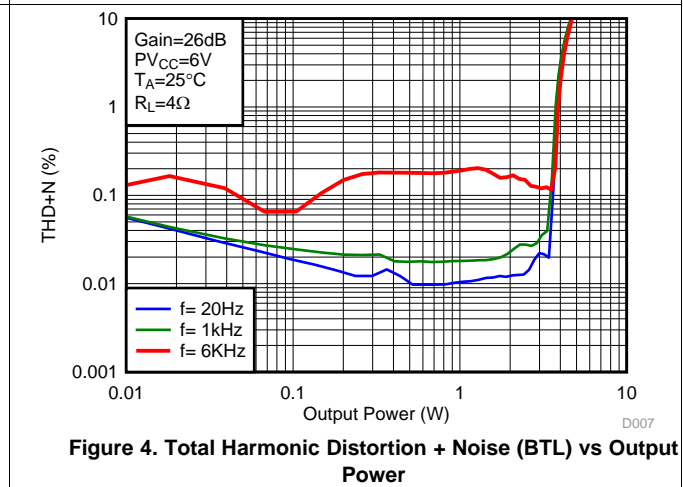
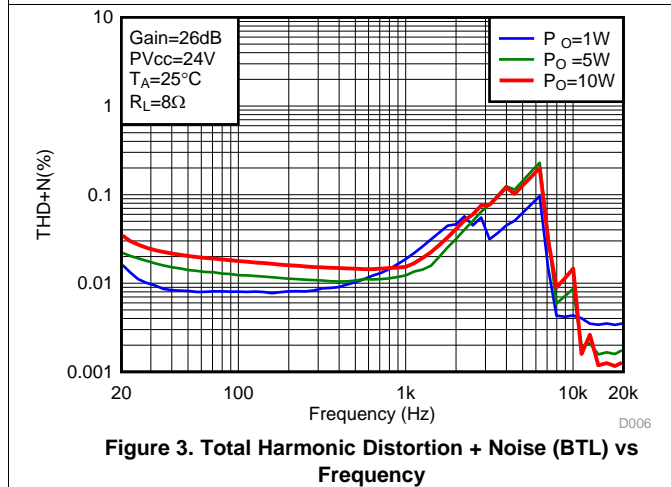
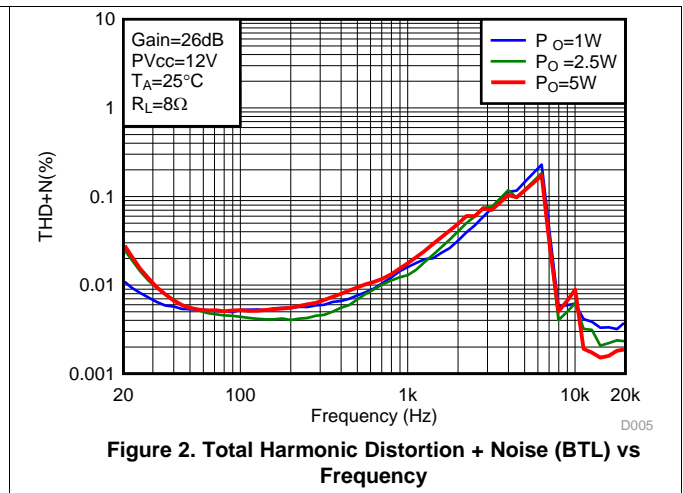
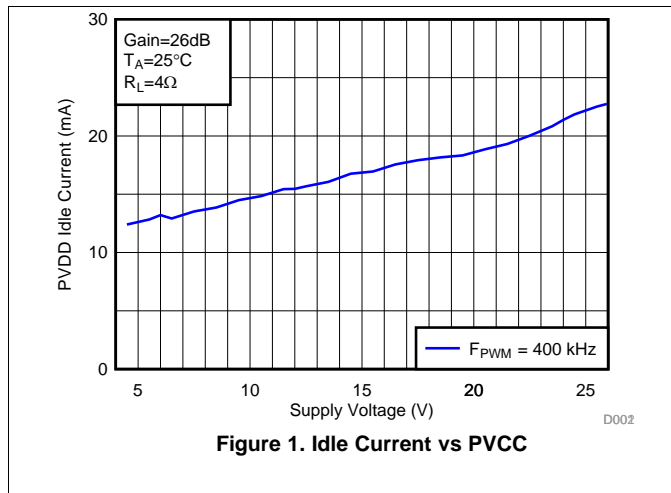

Typical Characteristics (continued)

$f_s = 400$  kHz, Hybrid Mode, TPA3126D2EVM Tested With AP2722. (unless otherwise noted)

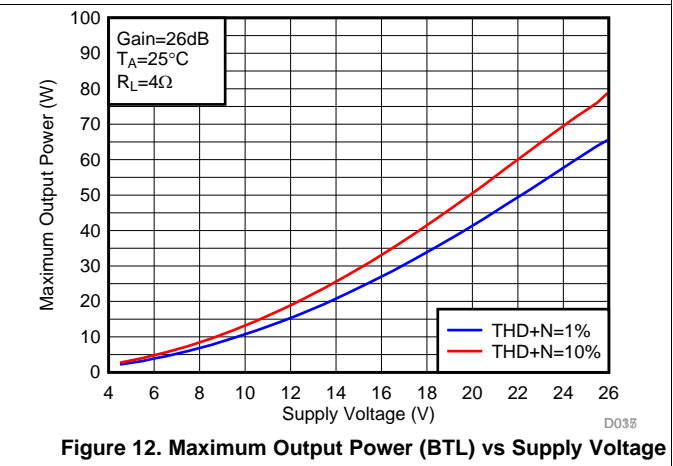
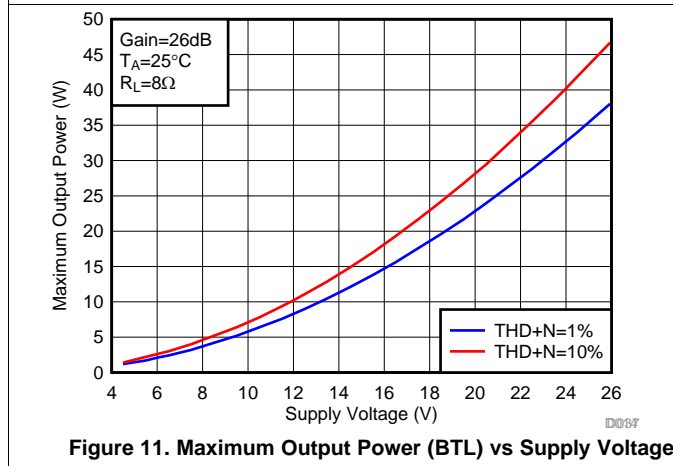
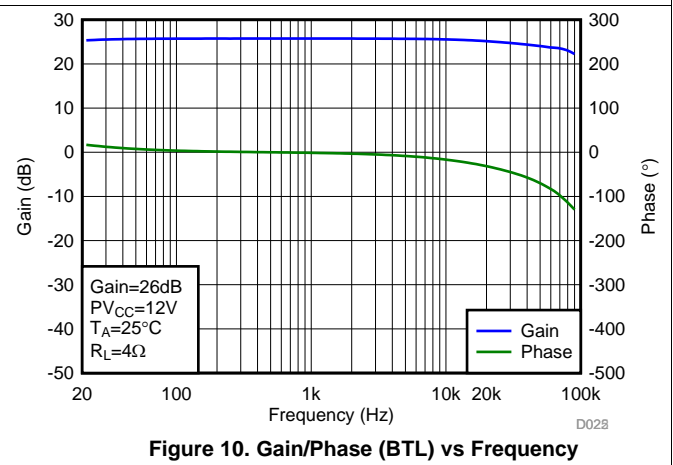
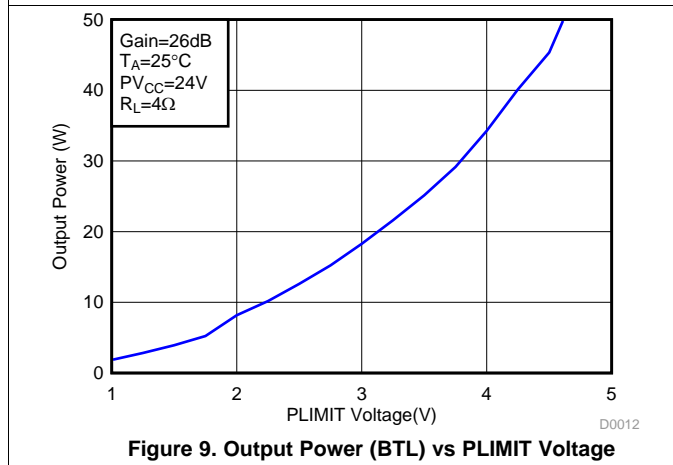
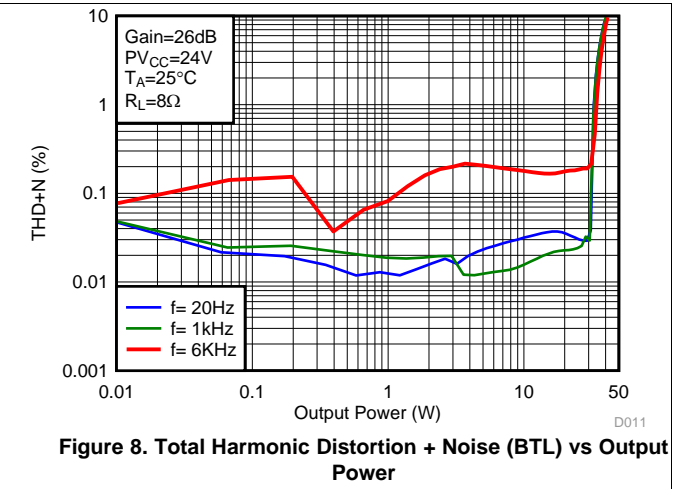
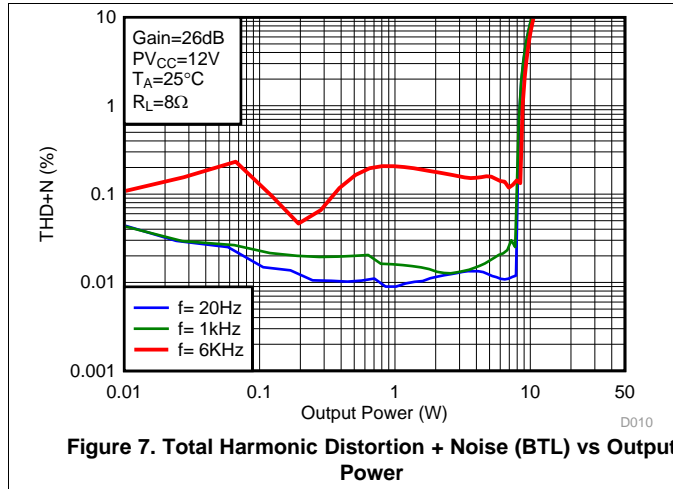

Typical Characteristics (continued)

$f_s = 400$  kHz, Hybrid Mode, TPA3126D2EVM Tested With AP2722. (unless otherwise noted)

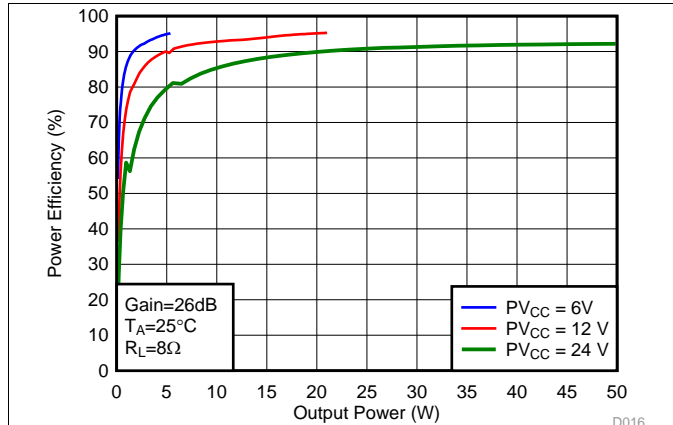

Figure 13. Power Efficiency (BTL) vs Output Power

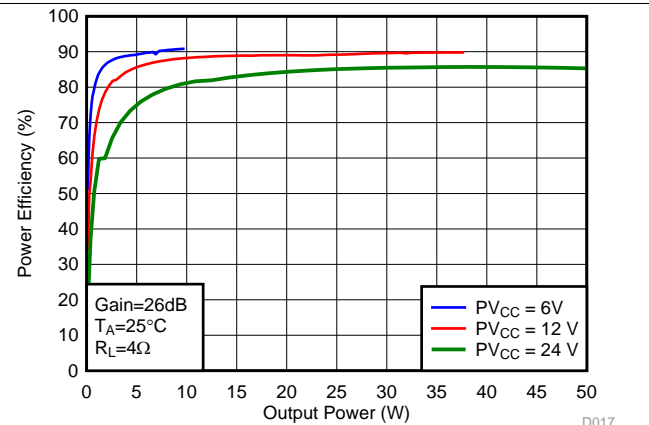

Figure 14. Power Efficiency (BTL) vs Output Power

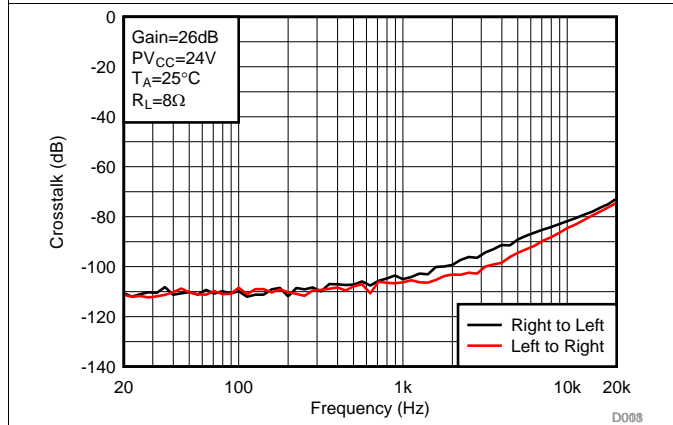

Figure 15. Crosstalk vs Frequency

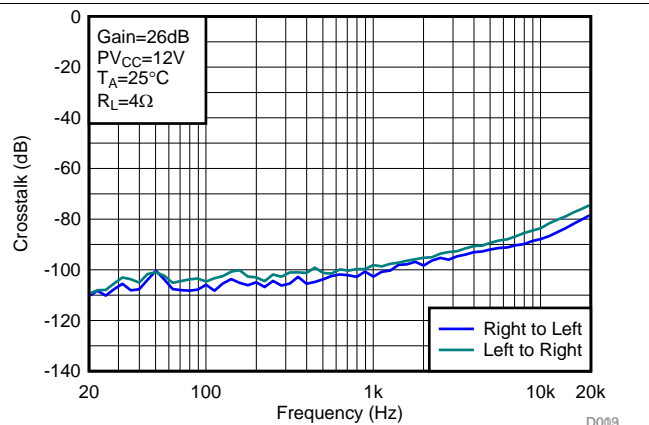

Figure 16. Crosstalk vs Frequency

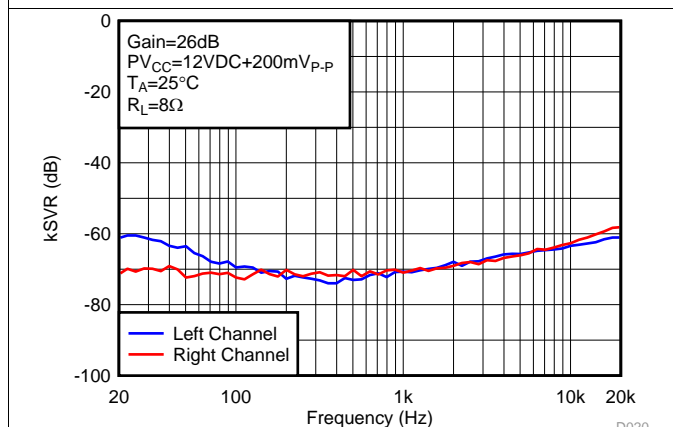

Figure 17. Supply Ripple Rejection Ratio (BTL) vs Frequency

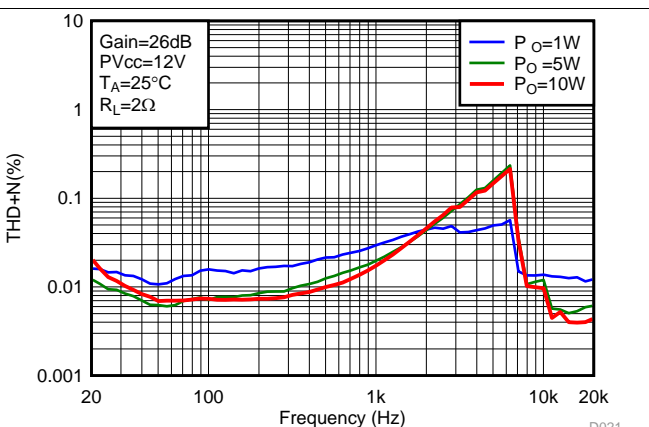
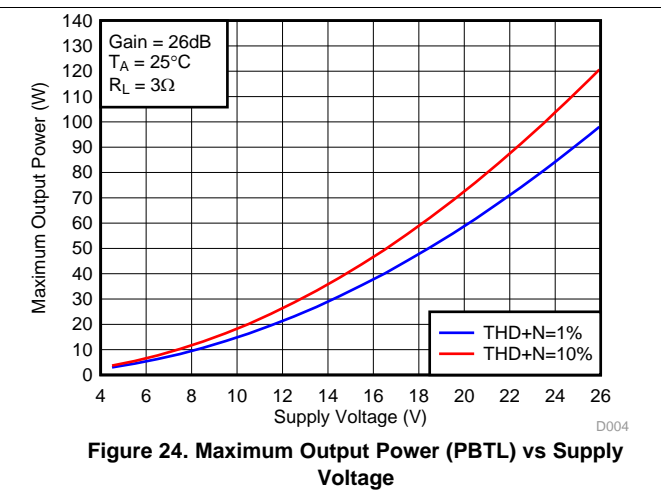
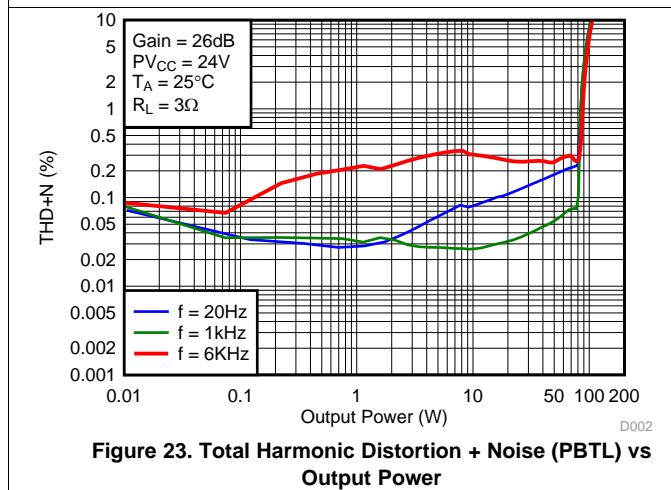
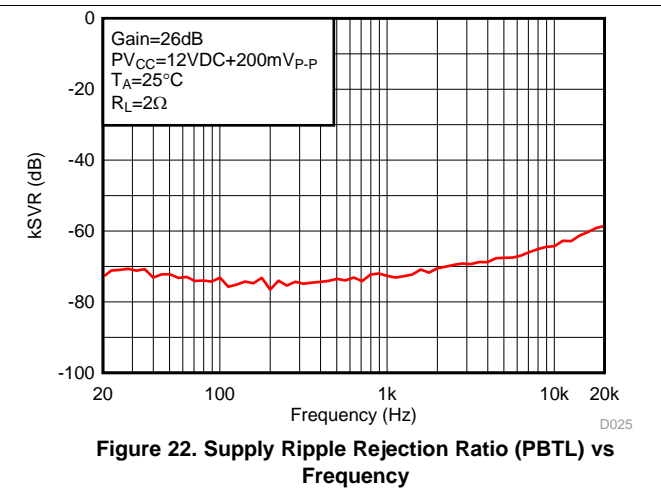
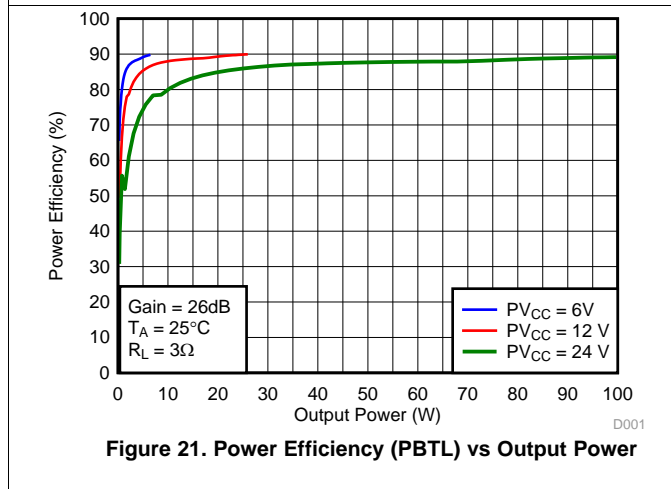
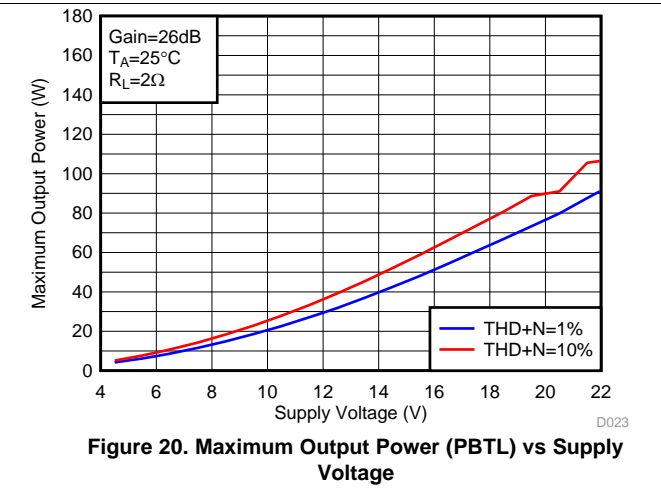
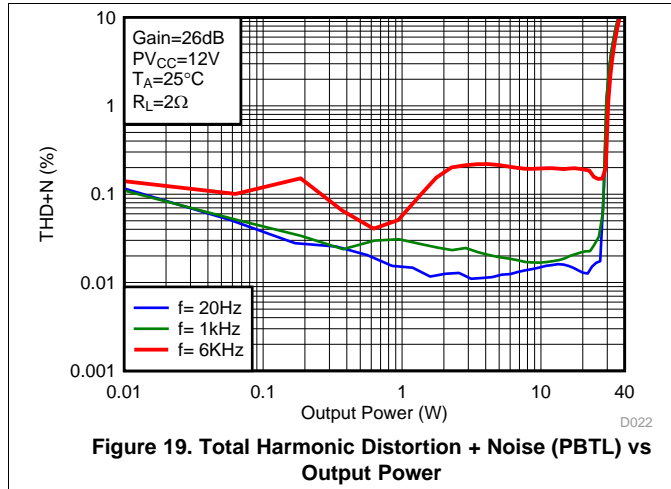

Figure 18. Total Harmonic Distortion + Noise (PBTL) vs Frequency

Typical Characteristics (continued)

$f_s = 400$  kHz, Hybrid Mode, TPA3126D2EVM Tested With AP2722. (unless otherwise noted)



## 8 Detailed Description

### 8.1 Overview

The analog-input Class-D amplifier TPA3126D2 is a performance upgrade to the prior generation TPA3116D2. It features a more efficient, 90-mΩ MOSFET, and has an extremely-low idle current of < 23 mA (24 V) in the standard LC filter configuration. The device can operate from the ultra-low-idle-loss modulation scheme, which enables low power dissipation in both idle condition and while playing music, optimized for battery-powered audio systems.

The TPA3126D2 supports both stereo and mono BTL modes, as well as mono PBTL mode. Comparing to the conventional Class-D amplifiers, in the mono BTL mode, the idle channel of the TPA3126D2 is not in the switching mode; therefore, it saves nearly half of the power loss, enabling low-power operation in single channel applications.

The device may be configured for either master or slave operation by using the SYNC pin. This configuration helps prevent the audible beats noise.

### 8.2 Functional Block Diagram

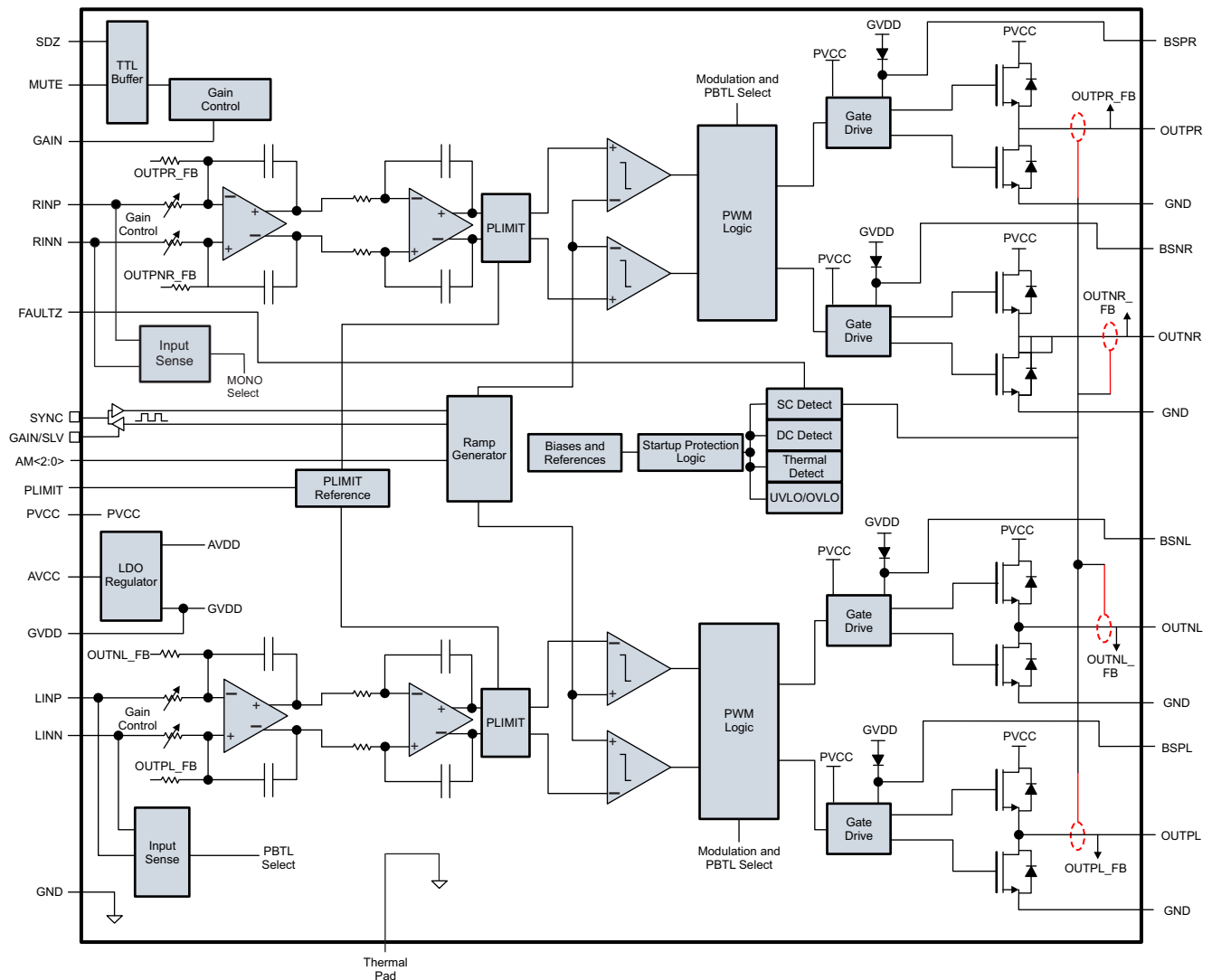

## 8.3 Feature Description

### 8.3.1 Gain Setting and Master and Slave

The gain of the TPA3126D2 is set by the voltage divider connected to the GAIN/SLV control pin. Master or Slave mode is also controlled by the same pin. An internal ADC is used to detect the 8 input states. The first four states set the GAIN in Master mode with gains of 20, 26, 32, and 36 dB respectively, while the next four states set the GAIN in Slave mode with gains of 20, 26, 32, and 36 dB respectively. The gain setting is latched during power-up and cannot be changed while the device is powered on. Table 1 lists the recommended resistor values for different state settings.

**Table 1. Gain and Master/Slave**

MASTER / SLAVE MODE	GAIN	R1 (to GND) <sup>(1)</sup>	R2 (to GVDD) <sup>(1)</sup>	INPUT IMPEDANCE
Master	20 dB	5.6 kΩ	OPEN	60 kΩ
Master	26 dB	20 kΩ	100 kΩ	30 kΩ
Master	32 dB	39 kΩ	100 kΩ	15 kΩ
Master	36 dB	47 kΩ	75 kΩ	9 kΩ
Slave	20 dB	51 kΩ	51 kΩ	60 kΩ
Slave	26 dB	75 kΩ	47 kΩ	30 kΩ
Slave	32 dB	100 kΩ	39 kΩ	15 kΩ
Slave	36 dB	100 kΩ	16 kΩ	9 kΩ

(1) Resistor tolerance should be 5% or better.

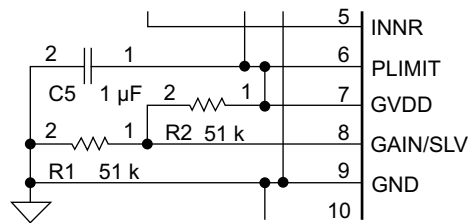

**Figure 25. Gain, Master/Slave**

In Master mode, the SYNC terminal is an output, while in Slave mode, the SYNC terminal is an input for a clock. TTL logic levels with compliance to GVDD.

### 8.3.2 Input Impedance

The TPA3126D2 input stage is a fully differential input stage and the input impedance changes with the gain setting from 7.3 kΩ at 36 dB gain to 50 kΩ at 20 dB gain. Table 1 lists the values from min to max gain. The tolerance of the input resistor value is ±20% so that the minimum value will be higher than 5.9 kΩ. The inputs must be AC-coupled to minimize the output DC-offset and ensure correct ramping of the output voltages during power-ON and power-OFF. The input AC-coupling capacitor along with the input impedance forms a high-pass filter with the following cut-off frequency:

$$f = \frac{1}{2\pi Z_i C_i} \quad (1)$$

If a flat bass response is required down to 20 Hz the recommended cut-off frequency is a tenth of that, 2 Hz. Table 2 lists the recommended AC-coupling capacitors for each gain setting. If a –3-dB frequency response is accepted at 20 Hz, 10 times lower capacitors (for example, a 1-μF capacitor) can be used.

**Table 2. Recommended Input AC-Coupling Capacitors**

GAIN	INPUT IMPEDANCE	INPUT CAPACITANCE	HIGH-PASS FILTER
20 dB	50 kΩ	1.5 μF	2.1 Hz
26 dB	25 kΩ	3.3 μF	1.9 Hz
32 dB	12.5 kΩ	5.6 μF	2.3 Hz
36 dB	7.3 kΩ	10 μF	2.2 Hz

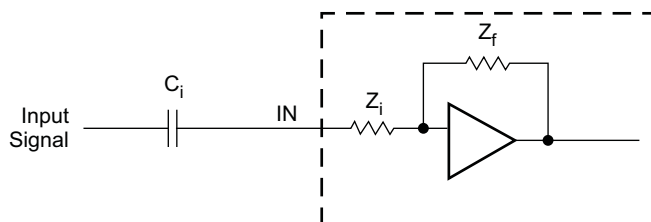

**Figure 26. Input Impedance**

The input capacitors should be a type of low leakage, such as quality electrolytic, tantalum, or ceramic capacitors. If a polarized type is used the positive connection should face the input pins which are biased to 3 Vdc.

**8.3.3 Startup and Shutdown Operation**

The TPA3126D2 employs a shutdown mode of operation designed to reduce supply current ( $I_{CC}$ ) to the absolute minimum level during periods of non-use for power conservation. The SDZ input terminal should be held high (see specification table for trip point) during normal operation when the amplifier is in use. Pulling SDZ low puts the outputs to mute and the amplifier to enter a low-current state. Do not leave SDZ unconnected, because the amplifier operation is unpredictable.

For the best power-off pop performance, place the amplifier in the shutdown mode prior to removing the power supply. The gain setting is selected at the end of the start-up cycle, and cannot be changed until the next power-up.

**8.3.4 PLIMIT Operation**

The TPA3126D2 has a built-in voltage limiter that can be used to limit the output voltage level below the supply rail. The amplifier operates as if it was powered by a lower supply voltage, and thereby, limits the output power. Add a resistor divider from GVDD to ground to set the voltage at the PLIMIT pin. An external reference may also be used if tighter tolerance is required. Add a 1-μF capacitor from pin PLIMIT to ground to ensure stability.

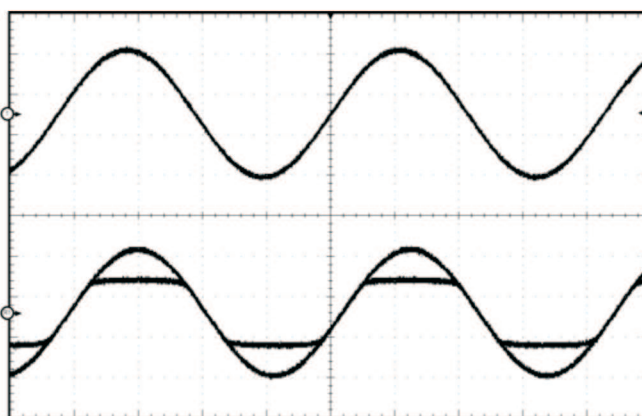

**Figure 27. Power Limit Example**

The PLIMIT circuit sets a limit on the output peak-to-peak voltage. This is done by limiting the duty cycle to a fixed maximum value. The limit can be considered as a "virtual" voltage rail which is lower than the supply connected to PVCC. The "virtual" rail is approximately four times the voltage at the PLIMIT pin. The output voltage can be used to calculate the maximum output power for a given maximum input voltage and speaker impedance.

$$P_{OUT} = \frac{\left( \left( \frac{R_L}{R_L + 2 \times R_S} \right) \times V_P \right)^2}{2 \times R_L} \quad \text{for unclipped power}$$

where

- $P_{OUT} (10\%THD) = 1.25 \times P_{OUT} (\text{unclipped})$
- $R_L$  is the load resistance.
- $R_S$  is the total series resistance including  $R_{DS(on)}$ , and output filter resistance.
- $V_P$  is the peak amplitude, which is limited by the "virtual" voltage rail. (2)

**Table 3. Power Limit Example**

PV <sub>CC</sub> (V)	PLIMIT VOLTAGE (V) <sup>(1)</sup>	R to GND	R to GVDD	OUTPUT VOLTAGE (V <sub>rms</sub> )
24 V	GVDD	Open	Short	17.9
24 V	3.3	45 kΩ	51 kΩ	12.67
24 V	2.25	24 kΩ	51 kΩ	9
12 V	GVDD	Open	Short	10.33
12 V	2.25	24 kΩ	51 kΩ	9
12 V	1.5	18 kΩ	68 kΩ	6.3

(1) PLIMIT measurements taken with EVM gain set to 26 dB and input voltage set to 1 V<sub>rms</sub>.

### 8.3.5 GVDD Supply

The GVDD Supply is used to power the gates of the output full bridge transistors. The GVDD supply can also be used to supply the PLIMIT and GAIN/SLV voltage dividers. Decouple GVDD with a X5R ceramic 1-μF capacitor to GND. The GVDD supply is not intended to be used for external supply. The current consumption should be limited by using resistor voltage dividers for GAIN/SLV and PLIMIT of 100 kΩ or more.

### 8.3.6 BSPx and BSNx Capacitors

The full H-bridge output stages use only NMOS transistors. Therefore, they require bootstrap capacitors for the high side of each output to turn on correctly. A 220-nF ceramic capacitor of quality X5R or better, rated for at least 16 V, must be connected from each output to the corresponding bootstrap input. (See the application circuit diagram in [Figure 34](#).) The bootstrap capacitors connected between the BSxx pins and corresponding output function as a floating power supply for the high-side N-channel power MOSFET gate drive circuitry. During each high-side switching cycle, the bootstrap capacitors hold the gate-to-source voltage high enough to keep the high-side MOSFETs turned on.

### 8.3.7 Differential Inputs

The differential input stage of the amplifier cancels any noise that appears on both input lines of the channel. To use the TPA3126D2 with a differential source, connect the positive lead of the audio source to the RINP or LINP input and the negative lead from the audio source to the RINN or LINN input. To use the TPA3126D2 with a single-ended source, AC ground the negative input through a capacitor equal in value to the input capacitor on positive and apply the audio source to either input. In a single-ended input application, the unused input should be AC grounded at the audio source instead of at the device input for best noise performance. For good transient performance, the impedance seen at each of the two differential inputs should be the same.

The impedance seen at the inputs should be limited to an RC time constant of 1 ms or less if possible to allow the input DC blocking capacitors to become completely charged during the 40-ms power-up time. If the input capacitors are not allowed to become completely charged, there will be some additional sensitivity to the component matching which can result in pop if the input components are not well matched.



### 8.3.8 Device Protection System

The TPA3126D2 contains a complete set of protection circuits carefully designed to make system design efficient as well as to protect the device against any kind of permanent failures due to short circuits, overload, over temperature, and under-voltage. The FAULTZ pin signals if an error is detected according to [Table 4](#):

**Table 4. Fault Reporting**

FAULT	TRIGGERING CONDITION (typical value)	FAULTZ	ACTION	LATCHED/SELF-CLEARING
Over Current	Output short or short to PVCC or GND	Low	Output high impedance	Latched
Over Temperature	$T_j > 150^\circ\text{C}$	Low	Output high impedance	Latched
Too High DC Offset	DC output voltage	Low	Output high impedance	Latched
Under Voltage on PVCC	$PVCC < 4.5\text{V}$	–	Output high impedance	Self-clearing
Over Voltage on PVCC	$PVCC > 27\text{V}$	–	Output high impedance	Self-clearing

### 8.3.9 DC Detect Protection

The TPA3126D2 has circuitry which protects the speakers from DC current which might occur due to defective capacitors on the input or shorts on the printed circuit board at the inputs. A DC detect fault is reported on the FAULT pin as a low state. The DC Detect fault causes the amplifier to shutdown by changing the state of the outputs to Hi-Z.

If automatic recovery from the short circuit protection latch is desired, connect the FAULTZ pin directly to the SDZ pin. Connecting the FAULTZ and SDZ pins allows the FAULTZ pin function to automatically drive the SDZ pin low which clears the DC Detect protection latch.

A DC Detect Fault is issued when the output differential voltage of either channel exceeds DC protection threshold level for more than 640 ms at the same polarity. [Table 5](#) shows some examples of the typical DC Detect Protection threshold for several values of the supply voltage. The Detect Protection Threshold feature protects the speaker from large DC currents or AC currents less than 2 Hz. To avoid nuisance faults due to the DC detect circuit, hold the SD pin low at power-up until the signals at the inputs are stable. Also, take care to match the impedance seen at the positive and negative inputs to avoid nuisance DC detect faults.

[Table 5](#) lists the minimum output offset voltages required to trigger the DC detect. The outputs must remain at or above the voltage listed in the table for more than 640 ms to trigger the DC detect.

**Table 5. DC Detect Threshold**

PVCC (V)	V <sub>OS</sub> - OUTPUT OFFSET VOLTAGE (V)
4.5	1.35
6	1.8
12	3.6
18	5.4

### 8.3.10 Short-Circuit Protection and Automatic Recovery Feature

The TPA3126D2 has protection from over current conditions caused by a short circuit on the output stage. The short circuit protection fault is reported on the FAULTZ pin as a low state. The amplifier outputs are switched to a high impedance state when the short circuit protection latch is engaged. The latch can be cleared by cycling the SDZ pin through the low state.

If automatic recovery from the short circuit protection latch is desired, connect the FAULTZ pin directly to the SDZ pin. Connecting the FAULTZ and SDZ pins allows the FAULTZ pin function to automatically drive the SDZ pin low which clears the short-circuit protection latch.

### 8.3.11 Thermal Protection

Thermal protection on the TPA3126D2 prevents damage to the device when the internal die temperature exceeds 150°C. This trip point has a  $\pm 15^\circ\text{C}$  tolerance from device to device. Once the die temperature exceeds the thermal trip point, the device enters into the shutdown state and the outputs are disabled. This is a latched fault.

Thermal protection faults are reported on the FAULTZ terminal as a low state.

If automatic recovery from the thermal protection latch is desired, connect the FAULTZ pin directly to the SDZ pin. This allows the FAULTZ pin function to automatically drive the SDZ pin low which clears the thermal protection latch.

### 8.3.12 Device Modulation Scheme

The TPA3126D2 has the option of running in either BD modulation or ultra-low idle current Hybrid Mode.

#### 8.3.12.1 BD Modulation

This is a modulation scheme that allows operation without the classic LC reconstruction filter when the amplifier is driving an inductive load with short speaker wires. Each output is switching from 0 volts to the supply voltage. The OUTPx and OUTNx are in phase with each other with no input so that there is little or no current in the speaker. The duty cycle of OUTPx is greater than 50% and OUTNx is less than 50% for positive output voltages. The duty cycle of OUTPx is less than 50% and OUTNx is greater than 50% for negative output voltages. The voltage across the load sits at 0V throughout most of the switching period, reducing the switching current, which reduces any  $I^2R$  losses in the load.

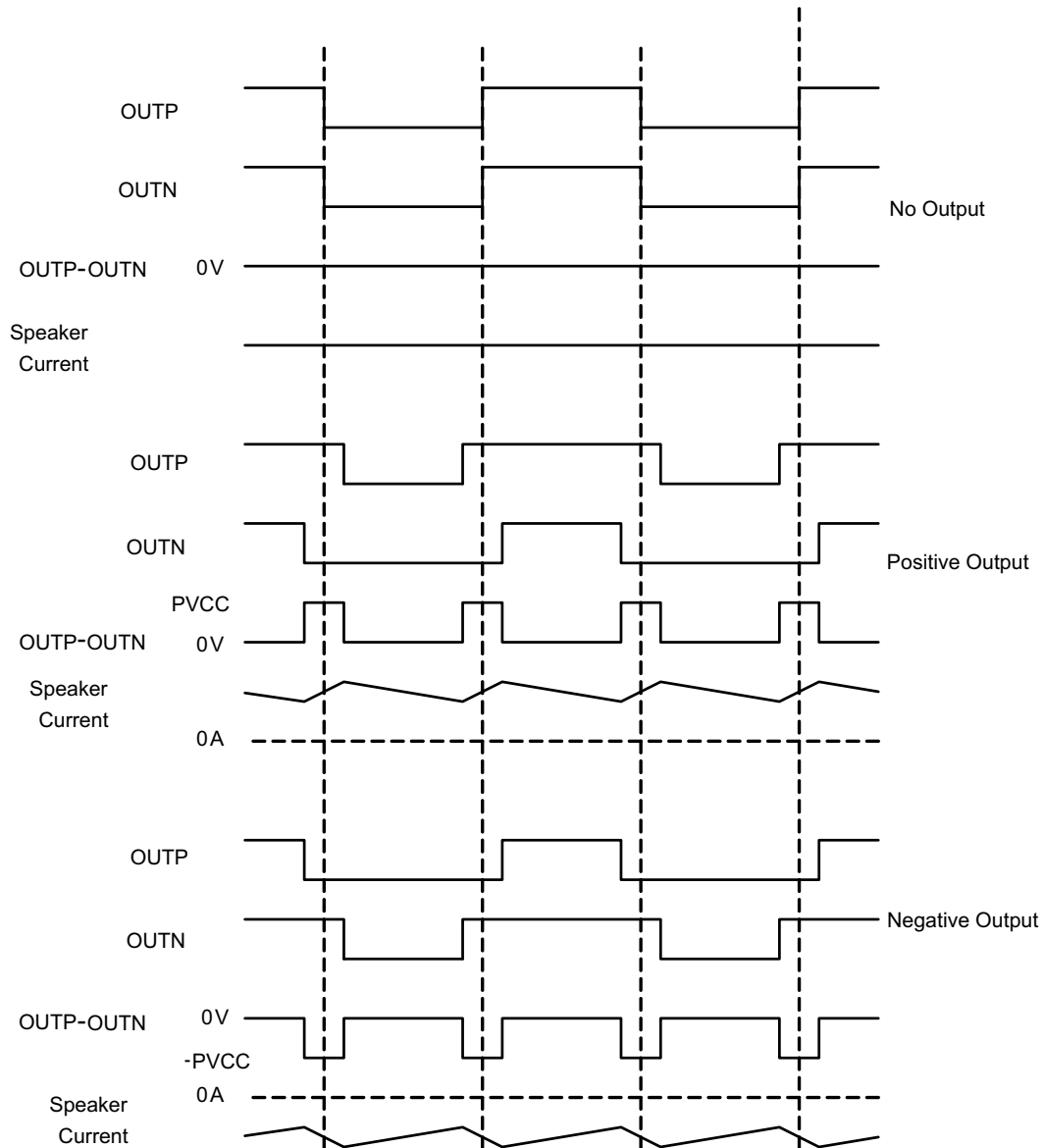

Figure 28. BD Mode Modulation

### 8.3.13 Efficiency: LC Filter Required with the Traditional Class-D Modulation Scheme

Many traditional Class-D amplifiers are based on the AD modulation. Due to the out-of-phase nature of a BTL or PBTL amplifier operating in the AD modulation, if no LC filter was present, the load sees the full PWM signal across its terminals. This causes a high-frequency ripple current to pass through the load, which leads to high power dissipation, poor efficiency, and potential speaker damage. The ripple current is large in the AD modulation scheme, because it is proportional to voltage multiplied by the time at that voltage. The differential voltage swing is  $2 \times V_{CC}$ , and the time at each voltage is half the period for the AD modulation scheme. An ideal LC filter is required to store the ripple current from each half cycle for the next half cycle, while any resistance causes power dissipation. The speaker is both resistive and reactive, whereas an LC filter is almost purely reactive.

The modulation schemes implemented in the TPA3126D2 have little loss in the load even without a filter because the pulses are short and the change in voltage is  $V_{CC}$  instead of  $2 \times V_{CC}$ . As the output power increases and the pulses widen, the ripple current can go up. In this case, the ripple current can be filtered with an LC filter for increased efficiency. However, in most applications the filter is not required.

With an LC filter, specifically as the cut-off frequency of the LC filter is smaller than the PWM switching frequency of the amplifier, the ripple current is reduced such that only a small residual ripple voltage is present after the LC filter. The filter has less resistance but higher impedance at the switching frequency than the speaker, which results in less power dissipation, hence increasing efficiency.

### 8.3.14 Ferrite Bead Filter Considerations

Using the Advanced Emissions Suppression Technology in the TPA3126D2, a high efficiency Class-D audio amplifier can be designed while minimizing interference to the surrounding circuits. Designing the amplifier can also be accomplished with only a low-cost ferrite bead filter. In this case the user must carefully select the ferrite bead used in the filter. One important aspect of the ferrite bead selection is the type of material used in the ferrite bead. Not all ferrite material is alike, therefore the user must select a material that is effective in the 10-MHz to 100-MHz range which is key to the operation of the Class-D amplifier. Many of the specifications regulating consumer electronics have emissions limits as low as 30-MHz. The ferrite bead filter should be used to block radiation in the 30-MHz and above range from appearing on the speaker wires and the power supply lines which are good antennas for these signals. The impedance of the ferrite bead can be used along with a small capacitor with a value in the range of 1000-pF to reduce the frequency spectrum of the signal to an acceptable level. For best performance, the resonant frequency of the ferrite bead or capacitor filter should be less than 10-MHz.

Also, the ferrite bead must be large enough to maintain its impedance at the peak currents expected for the amplifier. Some ferrite bead manufacturers specify the bead impedance at a variety of current levels. In this case it is possible to make sure the ferrite bead maintains an adequate amount of impedance at the peak current the amplifier will see. If these specifications are not available, the device can also estimate the bead current handling capability by measuring the resonant frequency of the filter output at low power and at maximum power. A change of resonant frequency of less than fifty percent under this condition is desirable. Examples of ferrite beads which have been tested and work well with the TPA3136D2 can be seen in the TPA3136D2EVM user guide [SLOU444](#).

A high quality ceramic capacitor is also required for the ferrite bead filter. A low ESR capacitor with good temperature and voltage characteristics will work best.

Additional EMC improvements may be obtained by adding snubber networks from each of the Class-D outputs to ground. Suggested values for a simple RC series snubber network would be  $18\text{-}\Omega$  in series with a 330-pF capacitor, although design of the snubber network is specific to different applications and must be designed with the consideration of the parasitic reactance of the printed circuit board as well as the audio amp. Take care to evaluate the stress on the component in the snubber network especially if the amp is running at high PVCC. Also, verify the layout of the snubber network is tight and returns directly to the GND pins on the IC.

[Figure 29](#) and [Figure 30](#) are TPA3126D2 EN55022 Radiated Emissions results uses TPA3126D2EVM with 8- $\Omega$  speakers.

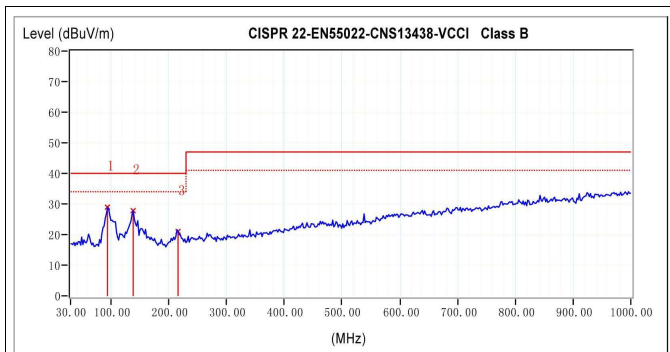

Figure 29. TPA3126D2 Radiated Emissions-Horizontal (PVCC=19V, P<sub>O</sub>=1W)

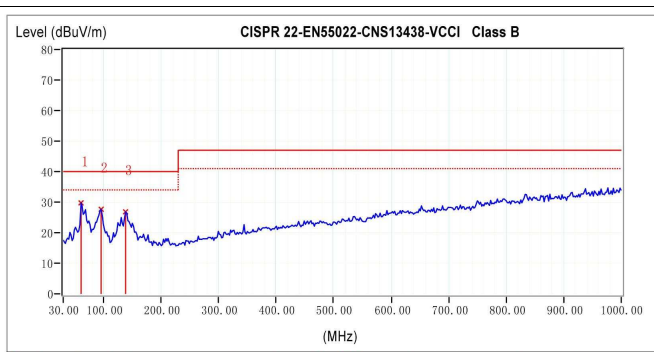

Figure 30. TPA3126D2 Radiated Emissions-Vertical (PVCC=19V, P<sub>O</sub>=1W)

### 8.3.15 When to Use an Output Filter for EMI Suppression

A complete LC reconstruction filter should be added in some circuit instances. These circumstances might occur if there are nearby circuits which are sensitive to noise. In these cases, a classic second order Butterworth filter similar to those shown in [Figure 31](#) can be used.

Some systems have little power supply decoupling from the AC line but are also subject to line conducted interference (LCI) regulations. These include systems powered by "wall warts" and "power bricks." In these cases, LC reconstruction filters can be the lowest-cost methods to pass LCI tests. Common mode chokes using low frequency ferrite material can also be effective in preventing line conducted interference.

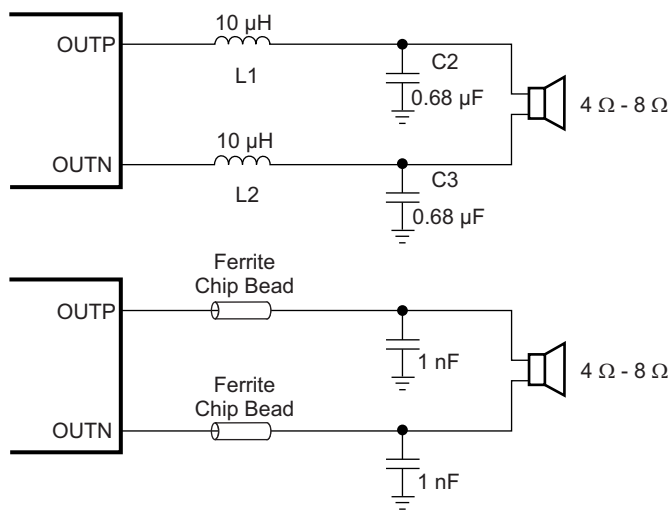

Figure 31. Output Filters

### 8.3.16 AM Avoidance EMI Reduction

Table 6. AM Frequencies

US AM FREQUENCY (kHz)	EUROPEAN AM FREQUENCY (kHz)	SWITCHING FREQUENCY (kHz)	AM2	AM1	AM0
540-917	540-914	500	0	0	1
917-1125	914-1122	600 (or 400)	0 0	1 0	0 0
1125-1375	1122-1373	500	0	0	1
1375-1547	1373-1548	600 (or 400)	0 0	1 0	0 0
1547-1700	1548-1701	600 (or 500)	0 0	1 0	0 1

## 8.4 Device Functional Modes

TPA3126D2 can be configured in either a stereo BTL (Bridge Tied Load) mode, mono BTL mode (only one output BTL channel active), or in a mono PBTL (Parallel Bridge Tied Load) mode.

### 8.4.1 Mono PBTL Mode

In mono PBTL mode, the device can deliver up to 100-W output power. Configuration steps for mono PBTL mode are as follows:

- Connect LINP and LINN directly to Ground (without capacitors), so the device is set in a mono PBTL mode during power up.
- Connect OUTPR and OUTNR together for the positive speaker terminal, and OUTNL and OUTPL together for the negative speaker terminal.
- Analog input signal is applied to RINP and RINN.

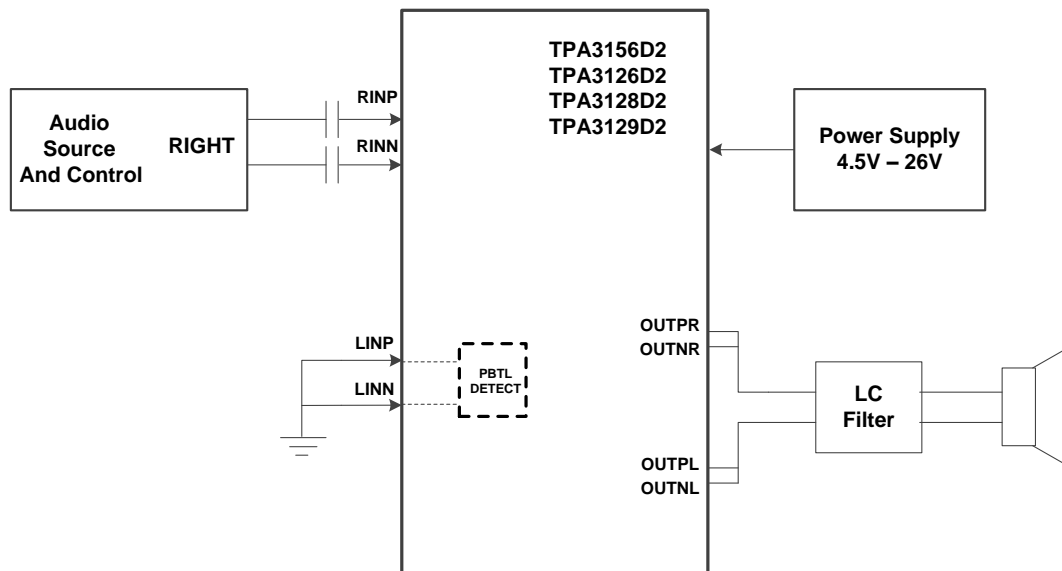

Copyright © 2018, Texas Instruments Incorporated

Figure 32. Mono PBTL Mode

**Device Functional Modes (continued)**

**8.4.2 Mono BTL Mode (Single Channel Mode)**

The TPA3126D2 can be connected in mono BTL mode while cutting the idle power-loss nearly by half.

- Connect RINP and RINN directly to Ground (without capacitors), so the device is set in mono BTL mode during power up.
- Connect OUTPL to the positive speaker terminal, and OUTNL to the negative speaker terminal.
- Analog input signal is applied to LINP and LINN.

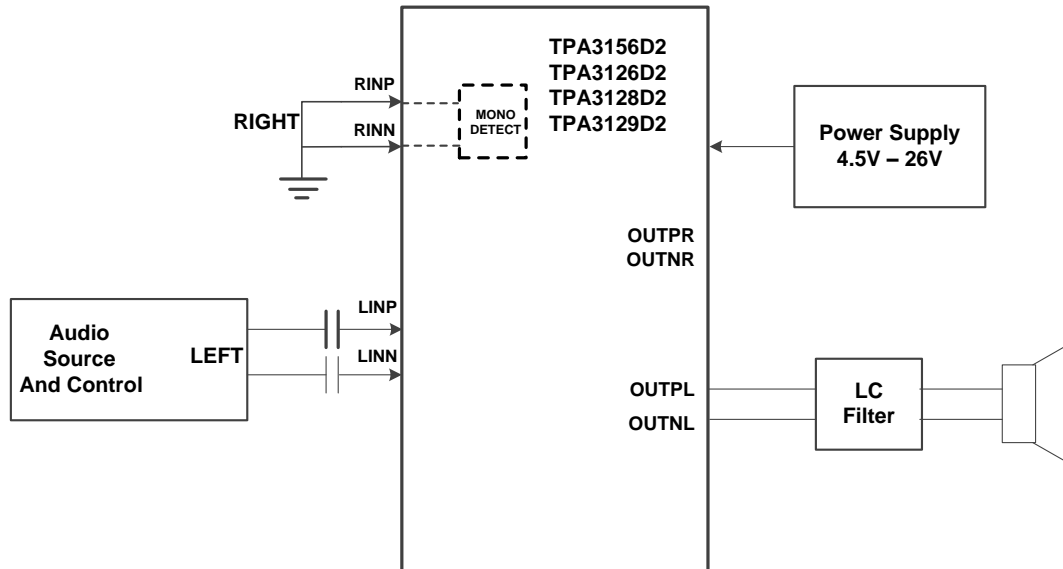

Copyright © 2018, Texas Instruments Incorporated

**Figure 33. Mono BTL Mode**

## 9 Application and Implementation

### NOTE

Information in the following applications sections is not part of the TI component specification, and TI does not warrant its accuracy or completeness. TI's customers are responsible for determining suitability of components for their purposes. Customers should validate and test their design implementation to confirm system functionality.

### 9.1 Application Information

#### 9.1.1 Typical Application

This section describes a 2.1 Master and Slave application. The Master (U1 TPA3126D2) is configured as stereo BTL outputs with 400-kHz switching frequency and no power limit implemented, and the Slave (U2) is configured as a mono PBTL output. Both U1 and U2 are setup with a gain of 26-dB. Inputs are connected for differential inputs.

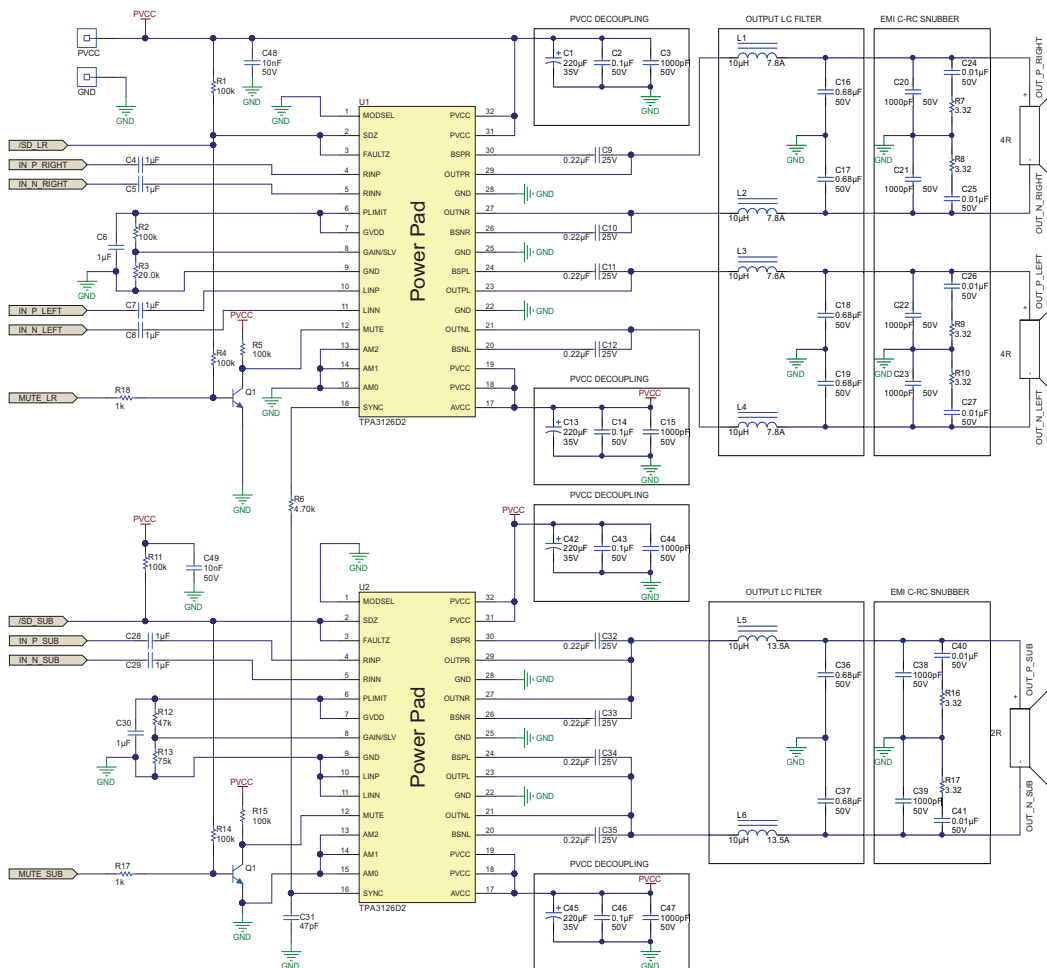

Figure 34. TPA3126D2 in a 2.1 Mode Application



## Application Information (continued)

### 9.1.1.1 Design Requirements

DESIGN PARAMETERS	EXAMPLE VALUE
Input voltage range PVCC	4.5 V to 26 V
PWM output frequencies	300kHz, 400 kHz, 500 kHz, 600 kHz, 1 MHz or 1.2 MHz
Maximum output power	2 × 50 W

### 9.1.1.2 Detailed Design Procedure

The TPA3126D2 devices are very flexible and easy-to-use Class D amplifiers; therefore, the design process is straightforward. Before beginning the design, gather the following information regarding the audio system.

- PVCC rail planned for the design
- Speaker or load impedance
- Maximum output power requirement
- Desired PWM frequency

#### 9.1.1.2.1 Select the PWM Frequency

Set the PWM frequency by using AM0, AM1 and AM2 pins.

#### 9.1.1.2.2 Select the Amplifier Gain and Master/Slave Mode

To select the amplifier gain setting, the designer must determine the maximum power target and the speaker impedance. Once these parameters have been determined, calculate the required output voltage swing which delivers the maximum output power.

Choose the lowest analog gain setting that corresponds to produce an output voltage swing greater than the required output swing for maximum power. The analog gain and master/slave mode can be set by selecting the voltage divider resistors (R1 and R2) on the Gain/SLV pin.

#### 9.1.1.2.3 Select Input Capacitance

Select the bulk capacitors at the PVCC inputs for proper voltage margin and adequate capacitance to support the power requirements. In practice, with a well-designed power supply, two 100- $\mu$ F, 50-V capacitors should be sufficient. One capacitor should be placed near the PVCC inputs at each side of the device. PVCC capacitors should be a low ESR type because they are being used in a fast-switching application.

#### 9.1.1.2.4 Select Decoupling Capacitors

Good quality decoupling capacitors must be added at each of the PVCC inputs to provide good reliability, good audio performance, and to meet regulatory requirements. X5R or better ratings should be used in this application. Consider temperature, ripple current, and voltage overshoots when selecting decoupling capacitors. Also, these decoupling capacitors should be located near the PVCC and GND connections to the device in order to minimize series inductances.

#### 9.1.1.2.5 Select Bootstrap Capacitors

Each of the outputs require bootstrap capacitors to provide gate drive for the high-side output FETs. For this design, use 0.22- $\mu$ F, 25-V capacitors of X5R quality or better.

### 9.1.1.3 Application Curves

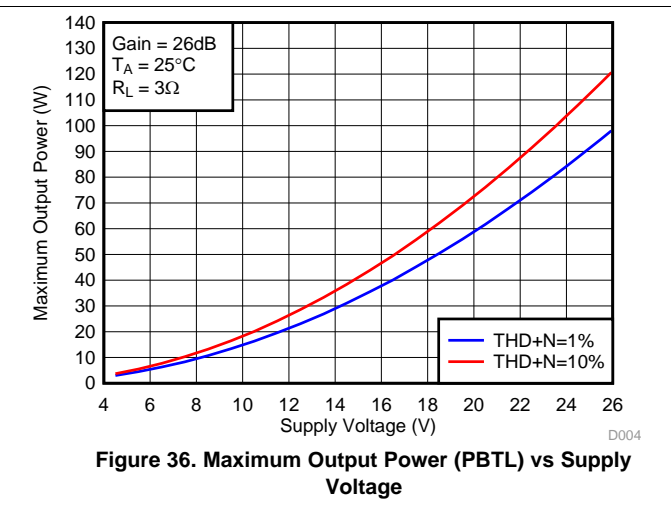
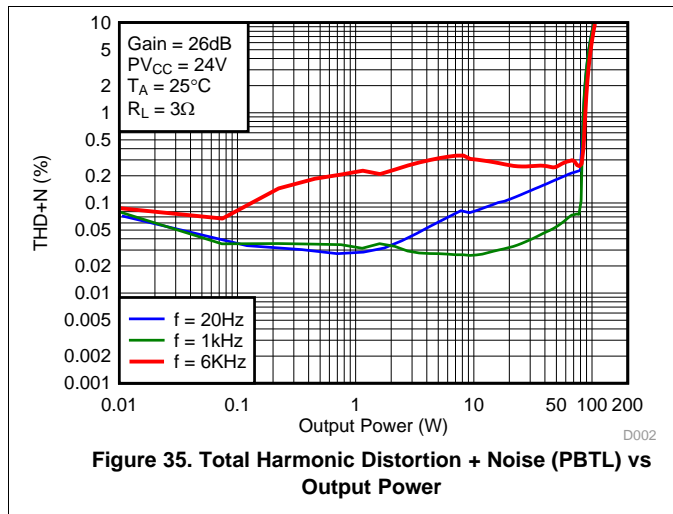

## 10 Power Supply Recommendations

The TPA3126D2 device requires an external power supply, between 4.5 V and 26 V, for the analog circuitry (AVCC) and the power stage (PVCC) of the amplifier. Several on-chip regulators are included on the TPA3126D2 to generate the voltages necessary for the internal circuitry of the audio path. The voltage regulators which have been integrated are sized only to provide the current necessary to power the internal circuitry. The external pins are provided only as a connection point for off-chip bypass capacitors to filter the supply. Connecting external circuitry to these regulator outputs may result in reduced performance and damage to the device. The AVCC supply feeds internal LDO including GVDD. This LDO output are connected to external pins for filtering purposes, but should not be connected to external circuits. GVDD LDO output have been sized to provide current necessary for internal functions but not for external loading.

### 10.1 Power Supply Mode

The TPA3126D2 supports both single and dual power supply modes. For dual power supply mode application, when AVCC is supplied with 4.5-V power, PVCC is recommended to be lower than 20 V. When PVCC is supplied with power greater than 20 V, AVCC is recommended to be higher than 6 V.

## 11 Layout

### 11.1 Layout Guidelines

The TPA3126D2 can be used with a small, inexpensive ferrite bead output filter in most applications. However, because the Class-D switching edges are fast, the layout of the printed circuit board must be planned carefully. The following suggestions help to meet EMC requirements.

- Decoupling capacitors — The high-frequency decoupling capacitors should be placed as close to the PVCC and AVCC terminals as possible. Large (100- $\mu$ F or greater) bulk power supply decoupling capacitors should be placed near the TPA3126D2 on the PVCC supplies. Local, high-frequency bypass capacitors should be placed as close to the PVCC pins as possible. These caps can be connected to the IC GND pad directly for an excellent ground connection. Consider adding a small, good quality low ESR ceramic capacitor between 220-pF and 1-nF, and a larger mid-frequency cap of value between 100-nF and 1- $\mu$ F also of good quality to the PVCC connections at each end of the chip.
- Minimize the current loop from each of the outputs through the ferrite bead filter and back to GND. The size of this current loop determines its effectiveness as an antenna.
- Grounding — The PVCC decoupling capacitors should connect to GND. All ground should be connected at the IC GND, which should be used as a central ground connection or star ground for the TPA3126D2.
- Output filter — The ferrite EMI filter (see [Figure 31](#)) should be placed as close to the output terminals as possible for the best EMI performance. The LC filter should be placed close to the outputs. The capacitors used in both the ferrite and LC filters should be grounded.

For an example layout, see the TPA3126D2 Evaluation Module (TPA3126D2EVM) User Guide ([SLOU506](#)). Both the EVM user manual and the thermal pad application reports, [SLMA002](#) and [SLMA004](#), are available on the TI Web site at <http://www.ti.com>.

## 11.2 Layout Example

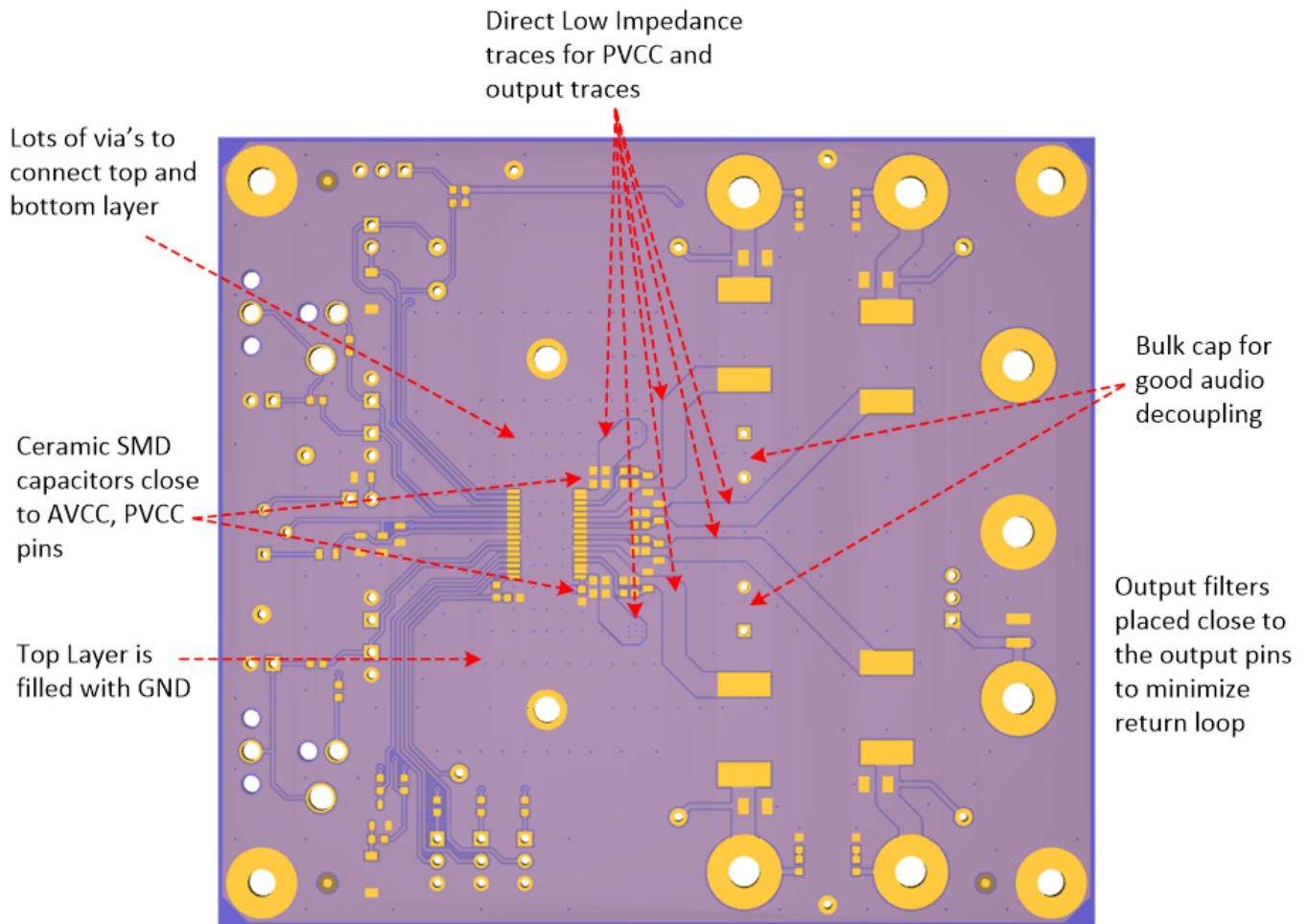

**Figure 37. Layout Example Top**

Layout Example (continued)

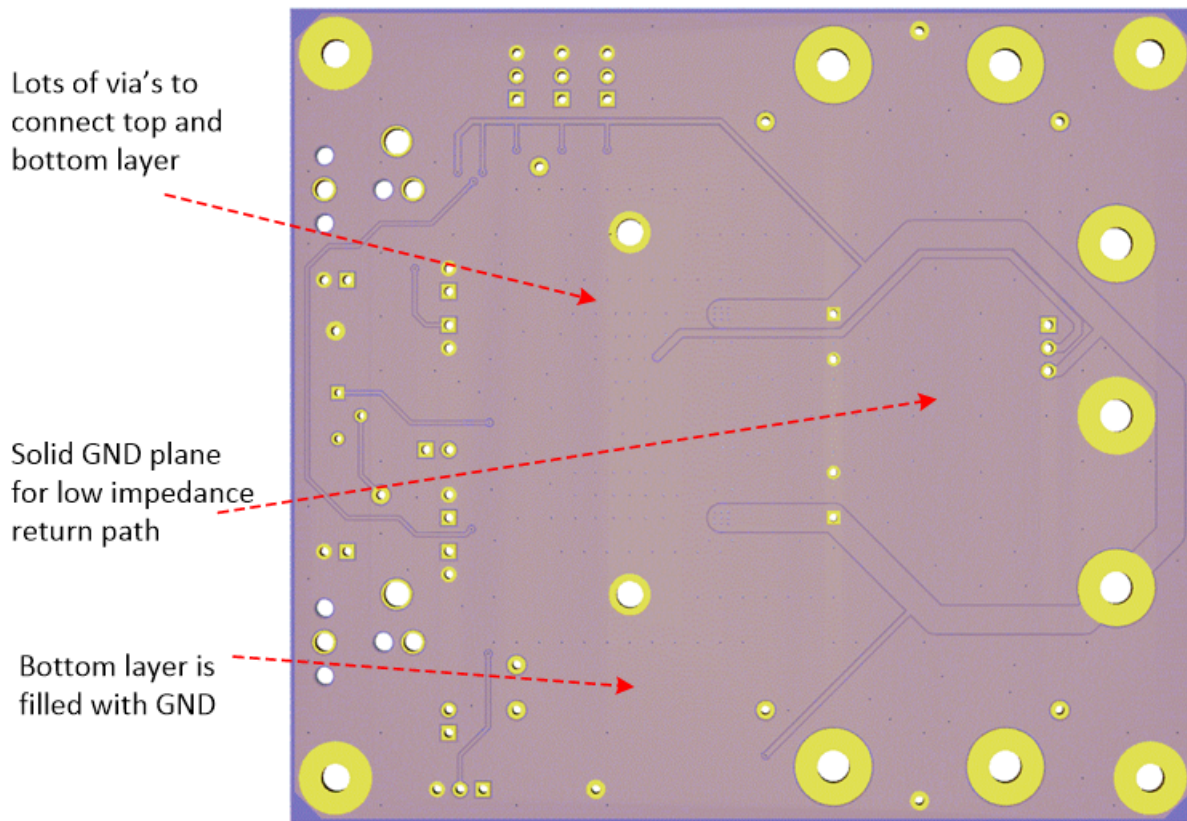

Figure 38. Layout Example Bottom

### 11.3 Heat Sink Used on the EVM

The heat sink (part number ATS-TI 10 OP-521-C1-R1) used on the EVM is an 14x25x50 mm extruded aluminum heat sink with three fins (see drawing below). For additional information on the heat sink, go to [www.qats.com](http://www.qats.com).

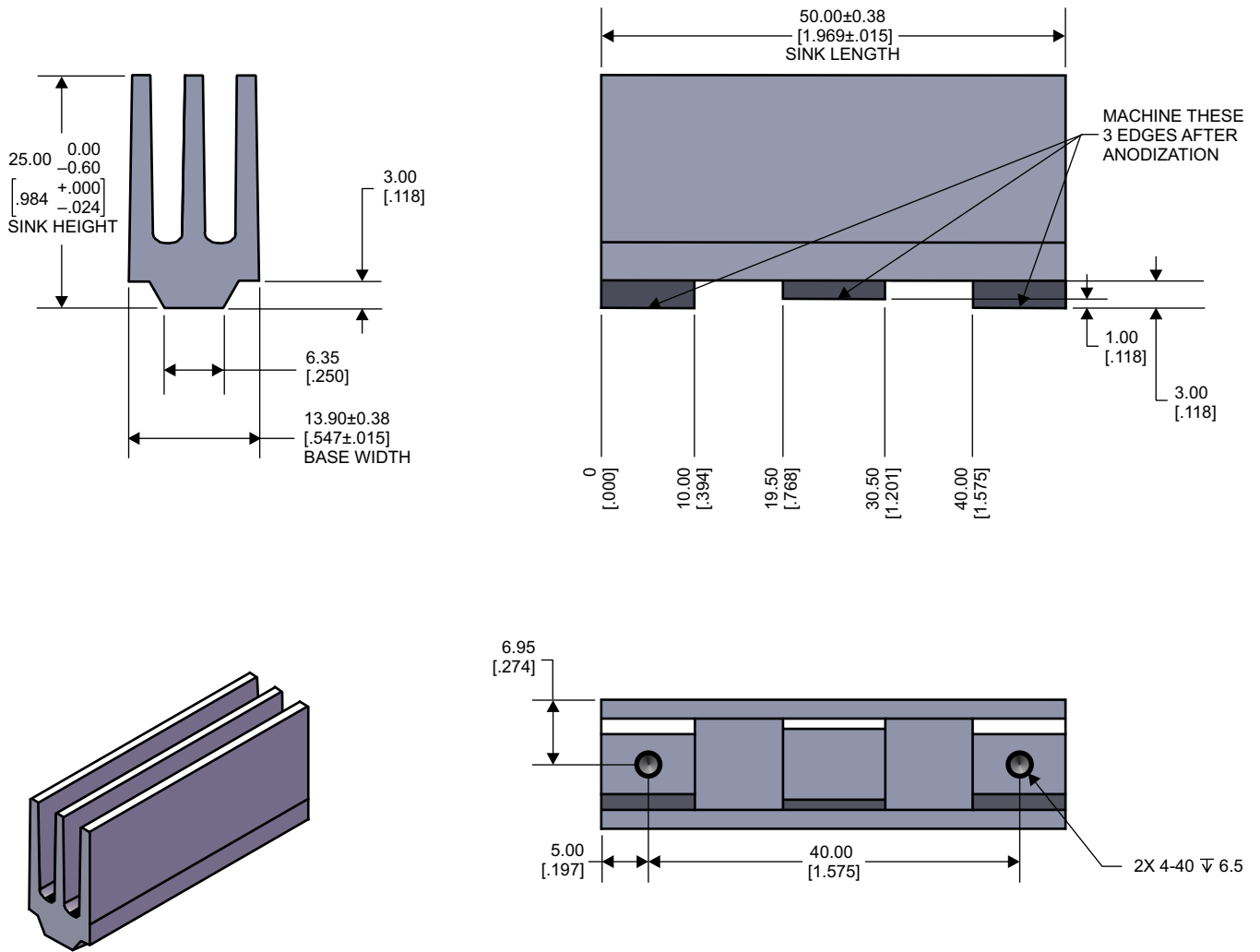

Figure 39. EVM Heat Sink

This size heat sink has shown to be sufficient for continuous output power. The crest factor of music and having airflow will lower the requirement for the heat sink size and smaller types can be used.

## 12 Device and Documentation Support

### 12.1 Device Support

#### 12.1.1 Development Support

[TPA3126D2 Evaluation Module User's Guide](#)

### 12.2 Receiving Notification of Documentation Updates

To receive notification of documentation updates, navigate to the device product folder on ti.com. In the upper right corner, click on *Alert me* to register and receive a weekly digest of any product information that has changed. For change details, review the revision history included in any revised document.

### 12.3 Related Documentation

For related documentation see the following:

- [Overview of system-level protection in class-D audio amplifiers](#)
- [Achieve Ultra-Low Idle Current With TPA3128D2](#)

### 12.4 Community Resources

The following links connect to TI community resources. Linked contents are provided "AS IS" by the respective contributors. They do not constitute TI specifications and do not necessarily reflect TI's views; see TI's [Terms of Use](#).

**TI E2E™ Online Community** *TI's Engineer-to-Engineer (E2E) Community*. Created to foster collaboration among engineers. At e2e.ti.com, you can ask questions, share knowledge, explore ideas and help solve problems with fellow engineers.

**Design Support** *TI's Design Support* Quickly find helpful E2E forums along with design support tools and contact information for technical support.

### 12.5 Trademarks

PowerPAD, E2E are trademarks of Texas Instruments.  
Bluetooth is a registered trademark of Bluetooth SIG, Inc.

### 12.6 Electrostatic Discharge Caution



These devices have limited built-in ESD protection. The leads should be shorted together or the device placed in conductive foam during storage or handling to prevent electrostatic damage to the MOS gates.

### 12.7 Glossary

[SLYZ022](#) — *TI Glossary*.



This glossary lists and explains terms, acronyms, and definitions.

## 13 Mechanical, Packaging, and Orderable Information

The following pages include mechanical, packaging, and orderable information. This information is the most current data available for the designated devices. This data is subject to change without notice and revision of this document. For browser-based versions of this data sheet, refer to the left-hand navigation.



**PACKAGING INFORMATION**

Orderable Device	Status (1)	Package Type	Package Drawing	Pins	Package Qty	Eco Plan (2)	Lead finish/ Ball material (6)	MSL Peak Temp (3)	Op Temp (°C)	Device Marking (4/5)	Samples
TPA3126D2DAD	ACTIVE	HTSSOP	DAD	32	46	RoHS & Green	NIPDAU	Level-3-260C-168 HR	-40 to 85	TPA 3126 D2	
TPA3126D2DADR	ACTIVE	HTSSOP	DAD	32	2000	RoHS & Green	NIPDAU	Level-3-260C-168 HR	-40 to 85	TPA 3126 D2	

(1) The marketing status values are defined as follows:

**ACTIVE:** Product device recommended for new designs.

**LIFEBUY:** TI has announced that the device will be discontinued, and a lifetime-buy period is in effect.

**NRND:** Not recommended for new designs. Device is in production to support existing customers, but TI does not recommend using this part in a new design.

**PREVIEW:** Device has been announced but is not in production. Samples may or may not be available.

**OBSOLETE:** TI has discontinued the production of the device.

(2) **RoHS:** TI defines "RoHS" to mean semiconductor products that are compliant with the current EU RoHS requirements for all 10 RoHS substances, including the requirement that RoHS substance do not exceed 0.1% by weight in homogeneous materials. Where designed to be soldered at high temperatures, "RoHS" products are suitable for use in specified lead-free processes. TI may reference these types of products as "Pb-Free".

**RoHS Exempt:** TI defines "RoHS Exempt" to mean products that contain lead but are compliant with EU RoHS pursuant to a specific EU RoHS exemption.

**Green:** TI defines "Green" to mean the content of Chlorine (Cl) and Bromine (Br) based flame retardants meet JS709B low halogen requirements of <=1000ppm threshold. Antimony trioxide based flame retardants must also meet the <=1000ppm threshold requirement.

(3) MSL, Peak Temp. - The Moisture Sensitivity Level rating according to the JEDEC industry standard classifications, and peak solder temperature.

(4) There may be additional marking, which relates to the logo, the lot trace code information, or the environmental category on the device.

(5) Multiple Device Markings will be inside parentheses. Only one Device Marking contained in parentheses and separated by a "-" will appear on a device. If a line is indented then it is a continuation of the previous line and the two combined represent the entire Device Marking for that device.

(6) Lead finish/Ball material - Orderable Devices may have multiple material finish options. Finish options are separated by a vertical ruled line. Lead finish/Ball material values may wrap to two lines if the finish value exceeds the maximum column width.

**Important Information and Disclaimer:** The information provided on this page represents TI's knowledge and belief as of the date that it is provided. TI bases its knowledge and belief on information provided by third parties, and makes no representation or warranty as to the accuracy of such information. Efforts are underway to better integrate information from third parties. TI has taken and continues to take reasonable steps to provide representative and accurate information but may not have conducted destructive testing or chemical analysis on incoming materials and chemicals. TI and TI suppliers consider certain information to be proprietary, and thus CAS numbers and other limited information may not be available for release.



In no event shall TI's liability arising out of such information exceed the total purchase price of the TI part(s) at issue in this document sold by TI to Customer on an annual basis.

**TAPE AND REEL INFORMATION**

**QUADRANT ASSIGNMENTS FOR PIN 1 ORIENTATION IN TAPE**

\*All dimensions are nominal

Device	Package Type	Package Drawing	Pins	SPQ	Reel Diameter (mm)	Reel Width W1 (mm)	A0 (mm)	B0 (mm)	K0 (mm)	P1 (mm)	W (mm)	Pin1 Quadrant
TPA3126D2DADR	HTSSOP	DAD	32	2000	330.0	24.4	8.6	11.5	1.6	12.0	24.0	Q1

TAPE AND REEL BOX DIMENSIONS



\*All dimensions are nominal

Device	Package Type	Package Drawing	Pins	SPQ	Length (mm)	Width (mm)	Height (mm)
TPA3126D2DADR	HTSSOP	DAD	32	2000	350.0	350.0	43.0

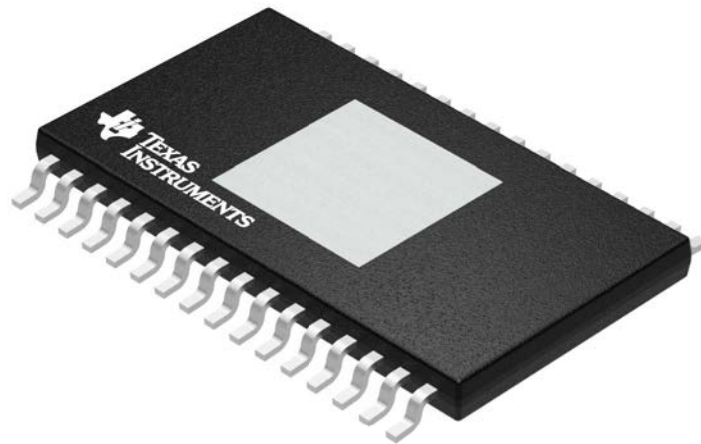

Images above are just a representation of the package family, actual package may vary.  
Refer to the product data sheet for package details.

DAD0032A

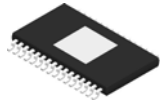

# PACKAGE OUTLINE

PowerPAD™ TSSOP - 1.15 mm max height

PLASTIC SMALL OUTLINE

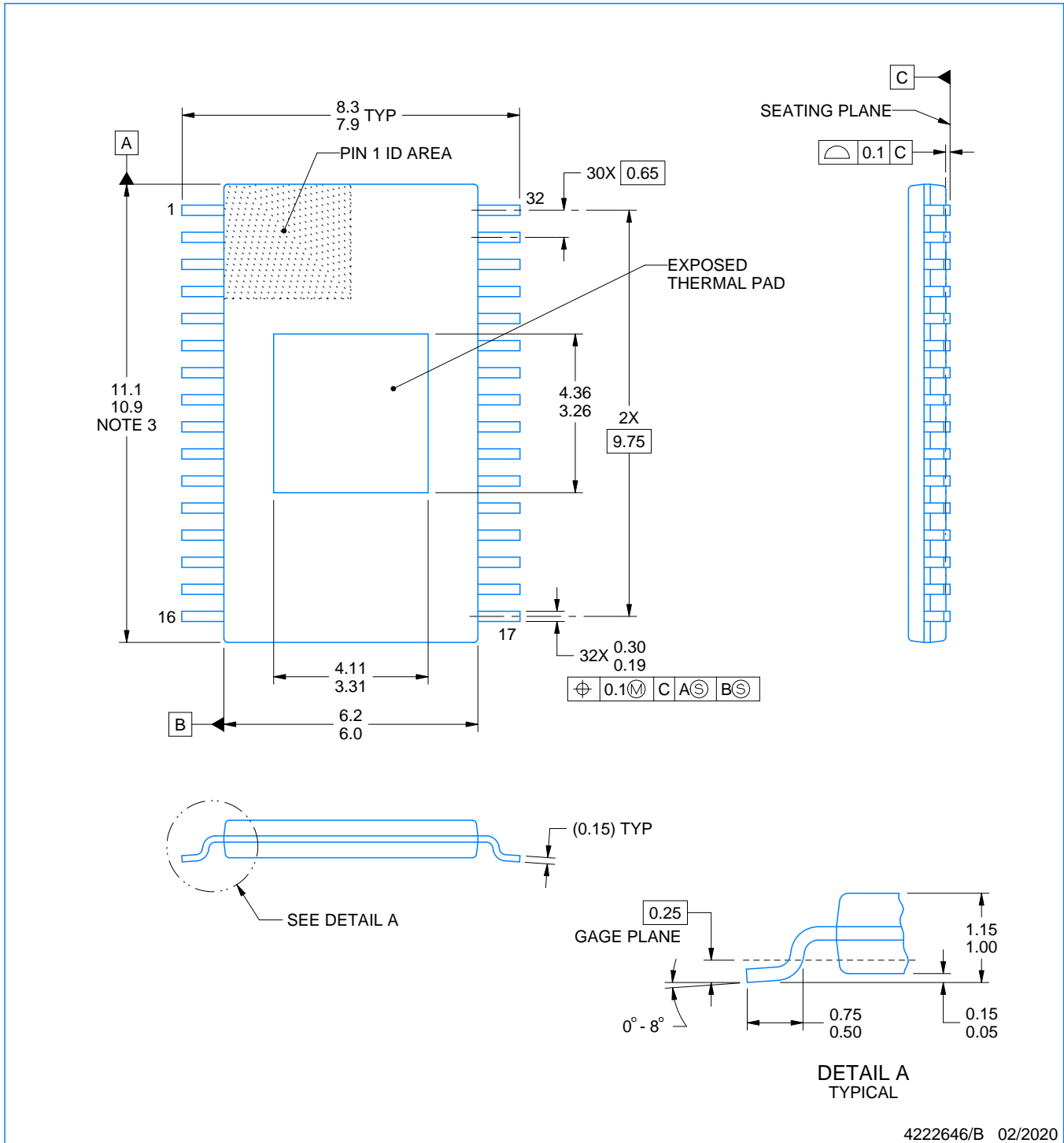

4222646/B 02/2020

PowerPAD is a trademark of Texas Instruments.

NOTES:

1. All linear dimensions are in millimeters. Any dimensions in parenthesis are for reference only. Dimensioning and tolerancing per ASME Y14.5M.
2. This drawing is subject to change without notice.
3. This dimension does not include mold flash, protrusions, or gate burrs. Mold flash, protrusions, or gate burrs shall not exceed 0.15 mm per side.
4. Reference JEDEC registration MO-153.

# EXAMPLE BOARD LAYOUT

DAD0032A

PowerPAD™ TSSOP - 1.15 mm max height

PLASTIC SMALL OUTLINE

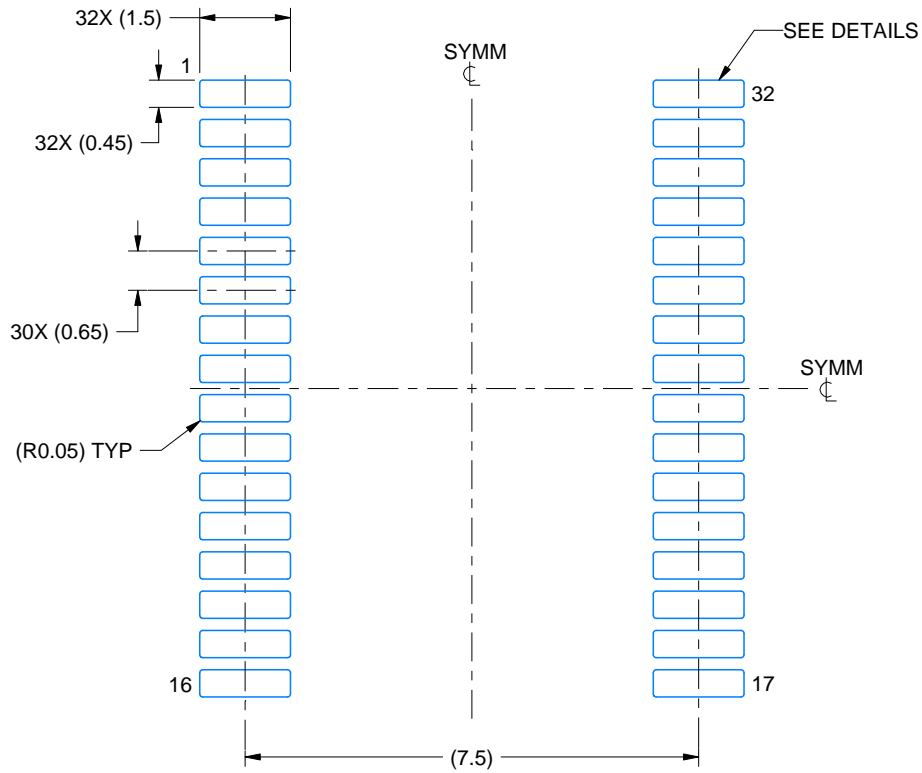

LAND PATTERN EXAMPLE  
SCALE:8X

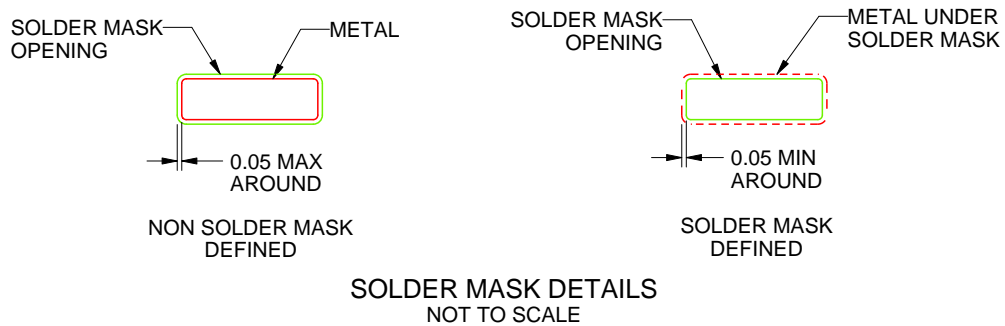

SOLDER MASK DETAILS  
NOT TO SCALE

4222646/B 02/2020

NOTES: (continued)

- 5. Publication IPC-7351 may have alternate designs.
- 6. Solder mask tolerances between and around signal pads can vary based on board fabrication site.

# EXAMPLE STENCIL DESIGN

DAD0032A

PowerPAD™ TSSOP - 1.15 mm max height

PLASTIC SMALL OUTLINE

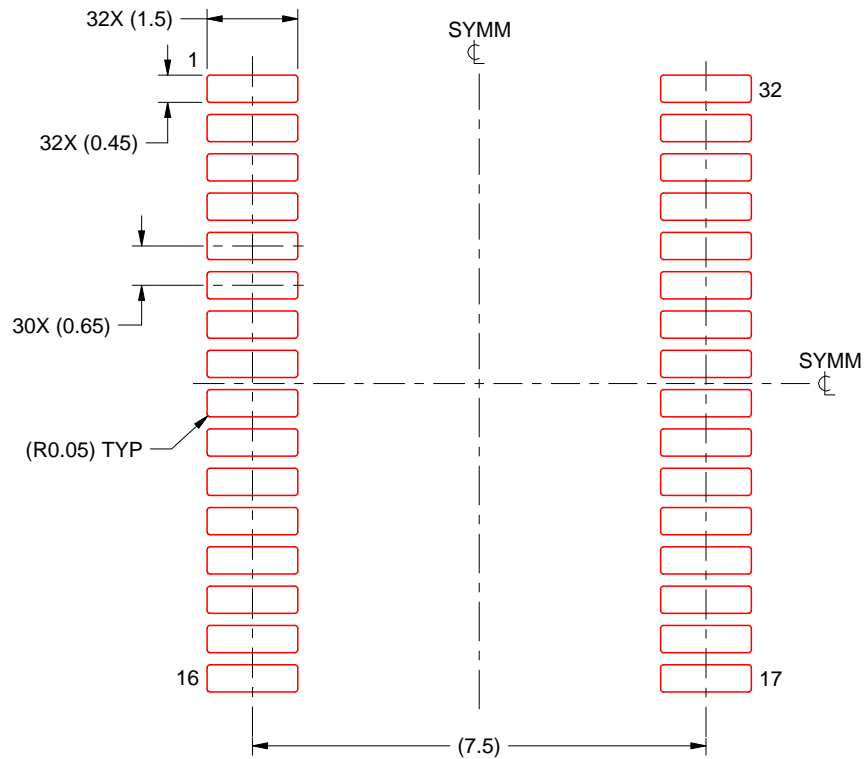

SOLDER PASTE EXAMPLE  
BASED ON 0.125 mm THICK STENCIL  
SCALE:8X

4222646/B 02/2020

NOTES: (continued)

7. Laser cutting apertures with trapezoidal walls and rounded corners may offer better paste release. IPC-7525 may have alternate design recommendations.
8. Board assembly site may have different recommendations for stencil design.

## IMPORTANT NOTICE AND DISCLAIMER

TI PROVIDES TECHNICAL AND RELIABILITY DATA (INCLUDING DATASHEETS), DESIGN RESOURCES (INCLUDING REFERENCE DESIGNS), APPLICATION OR OTHER DESIGN ADVICE, WEB TOOLS, SAFETY INFORMATION, AND OTHER RESOURCES "AS IS" AND WITH ALL FAULTS, AND DISCLAIMS ALL WARRANTIES, EXPRESS AND IMPLIED, INCLUDING WITHOUT LIMITATION ANY IMPLIED WARRANTIES OF MERCHANTABILITY, FITNESS FOR A PARTICULAR PURPOSE OR NON-INFRINGEMENT OF THIRD PARTY INTELLECTUAL PROPERTY RIGHTS.

These resources are intended for skilled developers designing with TI products. You are solely responsible for (1) selecting the appropriate TI products for your application, (2) designing, validating and testing your application, and (3) ensuring your application meets applicable standards, and any other safety, security, or other requirements. These resources are subject to change without notice. TI grants you permission to use these resources only for development of an application that uses the TI products described in the resource. Other reproduction and display of these resources is prohibited. No license is granted to any other TI intellectual property right or to any third party intellectual property right. TI disclaims responsibility for, and you will fully indemnify TI and its representatives against, any claims, damages, costs, losses, and liabilities arising out of your use of these resources.

TI's products are provided subject to TI's Terms of Sale ([www.ti.com/legal/termsofsale.html](http://www.ti.com/legal/termsofsale.html)) or other applicable terms available either on [ti.com](http://ti.com) or provided in conjunction with such TI products. TI's provision of these resources does not expand or otherwise alter TI's applicable warranties or warranty disclaimers for TI products.

Mailing Address: Texas Instruments, Post Office Box 655303, Dallas, Texas 75265  
Copyright © 2020, Texas Instruments Incorporated