

TPD4111K

The TPD4111K is a DC brushless motor driver using high-voltage PWM control. It is fabricated using a high-voltage SOI process.

The device contains a bootstrap circuit, PWM circuit, 3-phase decode logic, level shift high-side driver, low-side driver, IGBT outputs, FRDs, over-current and under-voltage protection circuits, and a thermal shutdown circuit.

It is easy to control a DC brush less motor by applying a signal from a motor controller and a Hall amp/ Hall IC to the TPD4111K.

Features

- Bootstrap circuit gives simple high-side supply.
- Bootstrap diode is built in.
- PWM and 3-phase decoder circuit are built in.
- 3-phase bridge output using IGBTs.
- Outputs Rotation pulse signals.
- FRDs are built in.
- Incorporating over-current and under-voltage protection, and thermal shutdown.
- Package: 23-pin HZIP.
- Compatible with Hall amp input and Hall IC input.

This product has a MOS structure and is sensitive to electrostatic discharge. When handling this product, ensure that the environment is protected against electrostatic discharge.

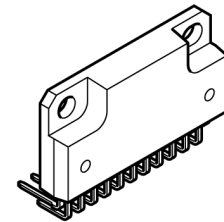

HZIP23-P-1.27F (LBR)

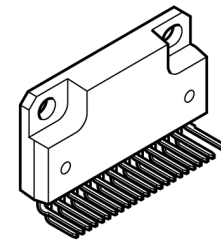

HZIP23-P-1.27G (LBF)

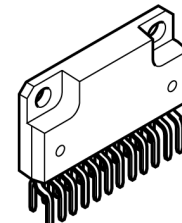

HZIP23-P-1.27H (LB2)

Weight

HZIP23-P-1.27F : 6.1 g (typ.)

HZIP23-P-1.27G : 6.1 g (typ.)

HZIP23-P-1.27H : 6.1 g (typ.)

Pin Assignment

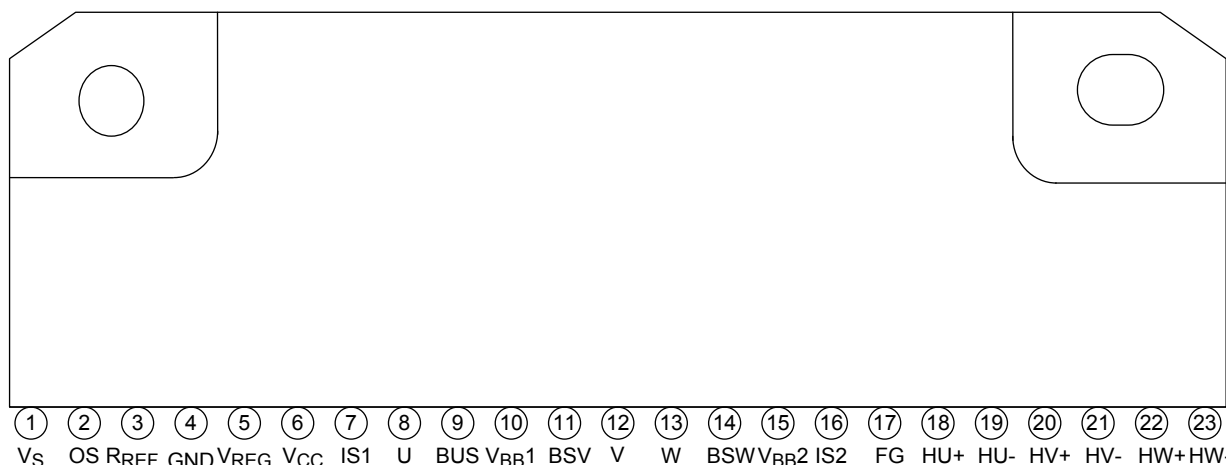

Marking

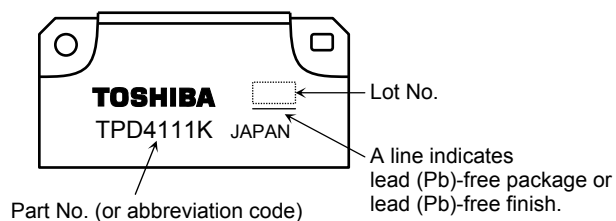

Block Diagram

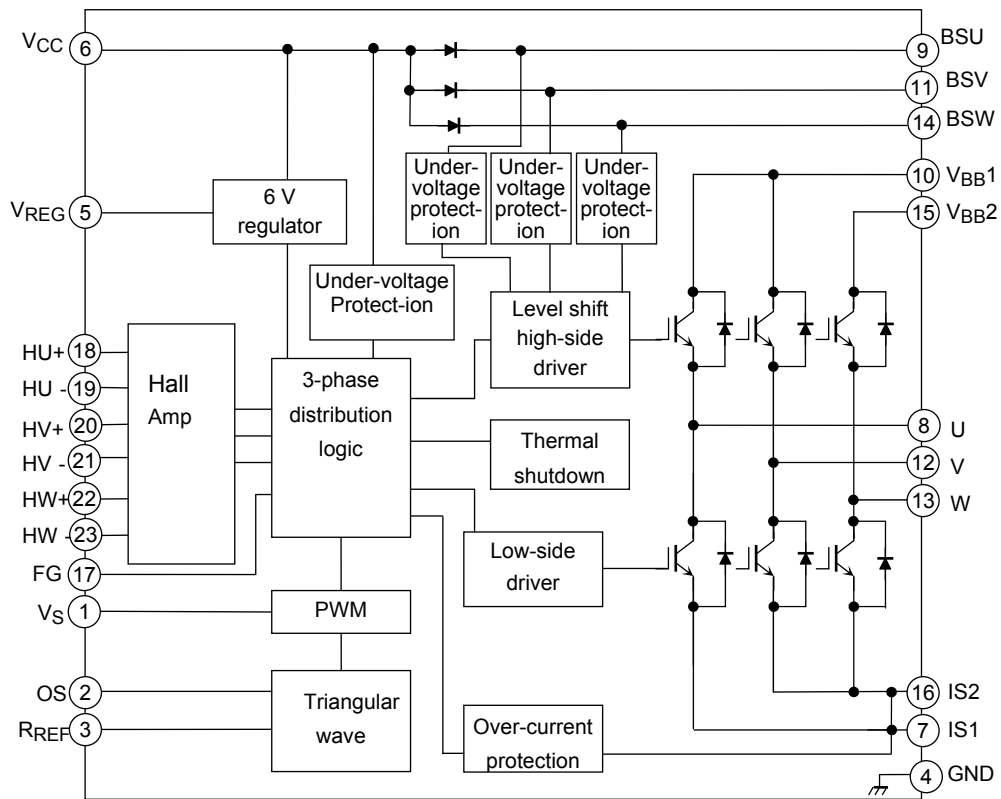

Pin Description

Pin No.	Symbol	Pin Description
1	V _S	Speed control signal input pin. (PWM reference voltage input pin)
2	OS	PWM triangular wave oscillation frequency setup pin (Connect a capacitor to this pin.)
3	R _{REF}	PWM triangular wave oscillation frequency setup pin (Connect a resistor to this pin.)
4	GND	Ground pin
5	V _{REG}	6 V regulator output pin
6	V _{CC}	Control power supply pin
7	IS1	IGBT emitter/FRD anode pin
8	U	U-phase output pin
9	BUS	U-phase bootstrap capacitor connecting pin
10	V _{BB1}	U and V-phase high-voltage power supply input pin
11	BSV	V-phase bootstrap capacitor connecting pin
12	V	V-phase output pin
13	W	W-phase high-voltage power supply input pin
14	BSW	W-phase bootstrap capacitor connecting pin
15	V _{BB2}	W-phase high-voltage power supply input pin
16	IS2	IGBT emitter/FRD anode pin
17	FG	Rotation pulse output pin. (open drain)
18	HU+	U-phase Hall sensor signal input pin (Hall IC can be used.)
19	HU-	U-phase Hall sensor signal input pin (Hall IC can be used.)
20	HV+	V-phase Hall sensor signal input pin (Hall IC can be used.)
21	HV-	V-phase Hall sensor signal input pin (Hall IC can be used.)
22	HW+	W-phase Hall sensor signal input pin (Hall IC can be used.)
23	HW-	W-phase Hall sensor signal input pin (Hall IC can be used.)

Equivalent Circuit of Input Pins

Internal circuit diagram of HU+, HU-, HV+, HV-, HW+, HW- input pins

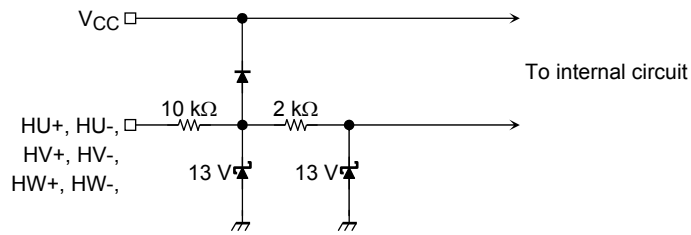

Internal circuit diagram of VS pin

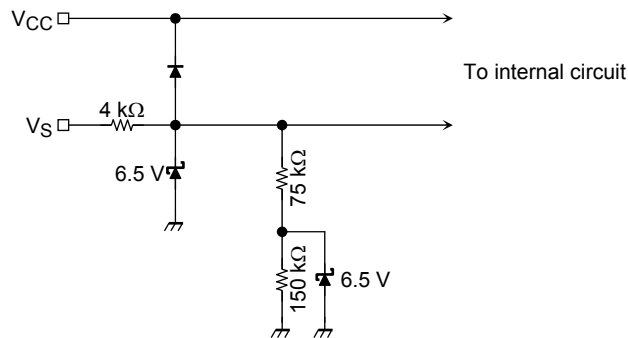

Internal circuit diagram of FG pin

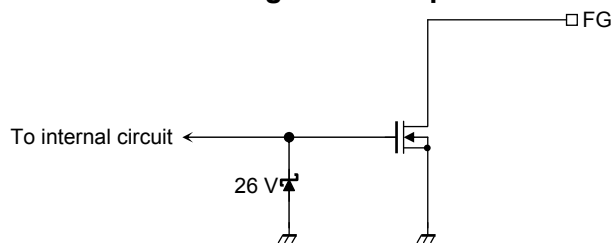

Timing Chart

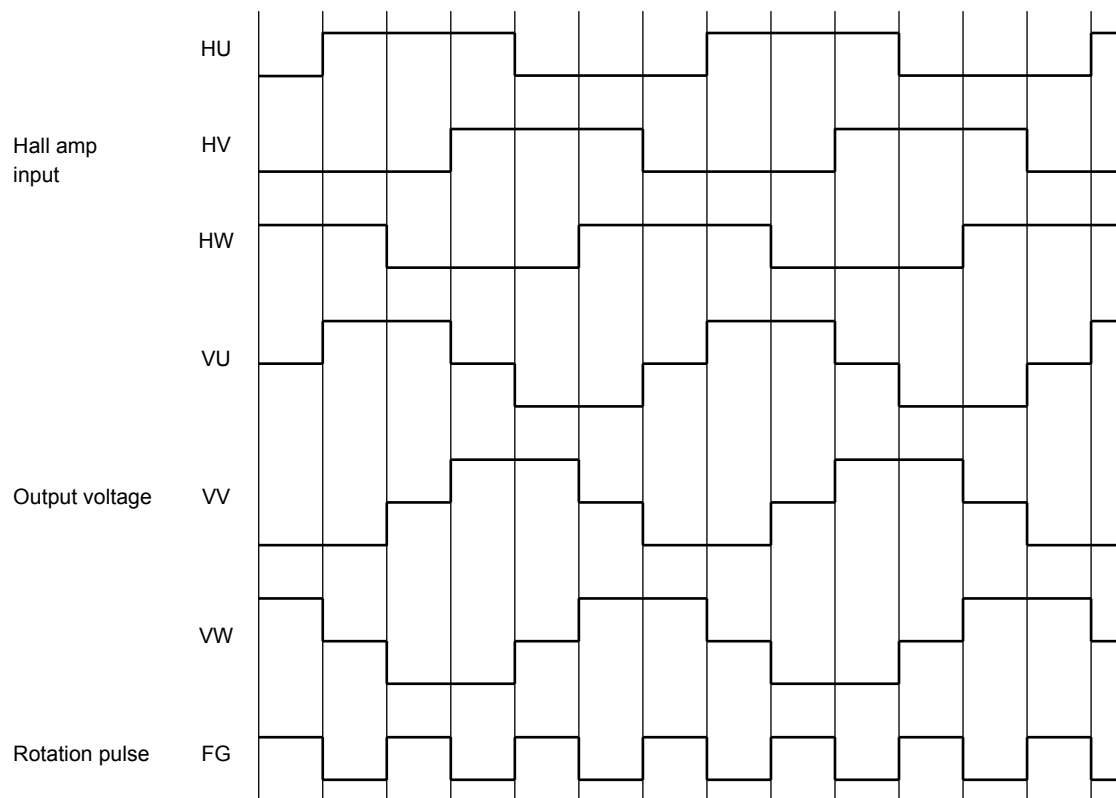

* : Hall input logic high (H) refers to IN+>IN-.

Truth Table

Hall amp Input			U Phase		V Phase		W Phase		FG
HU	HV	HW	Upper Arm	Lower Arm	Upper Arm	Lower Arm	Upper Arm	Lower Arm	
H	L	H	ON	OFF	OFF	ON	OFF	OFF	L
H	L	L	ON	OFF	OFF	OFF	OFF	ON	H
H	H	L	OFF	OFF	ON	OFF	OFF	ON	L
L	H	L	OFF	ON	ON	OFF	OFF	OFF	H
L	H	H	OFF	ON	OFF	OFF	ON	OFF	L
L	L	H	OFF	OFF	OFF	ON	ON	OFF	H
L	L	L	OFF	OFF	OFF	OFF	OFF	OFF	L
H	H	H	OFF	OFF	OFF	OFF	OFF	OFF	L

* : Hall input logic high (H) refers to IN+>IN-.

Absolute Maximum Ratings (Ta = 25°C)

Characteristics	Symbol	Rating	Unit
Power supply voltage	V _{BB}	250	V
	V _{CC}	20	V
Output current (DC)	I _{out}	1	A
Output current (pulse)	I _{out}	2	A
Input voltage (except V _S)	V _{IN}	-0.5 to V _{REG} + 0.5	V
Input voltage (only V _S)	V _S	8.2	V
V _{REG} current	I _{REG}	50	mA
Power dissipation (Ta = 25°C)	P _C	4	W
Power dissipation (Tc = 25°C)	P _C	20	W
Operating junction temperature	T _{jopr}	-20 to 135	°C
Junction temperature	T _j	150	°C
Storage temperature	T _{stg}	-55 to 150	°C
Lead-heat sink isolation voltage	V _{hs}	1000 (1 min)	V _{rms}

In case that the IC is erroneously connected to 200 VAC power supply, it can withstand a voltage of up to 315 V for 1 min under the condition of V_S < 1.1 V.

Electrical Characteristics (Ta = 25°C)

Characteristics	Symbol	Test Condition	Min	Typ.	Max	Unit
Operating power supply voltage	V _{BB}	—	50	—	185	V
	V _{CC}	—	13.5	15	17.5	
Current dissipation	I _{BB}	V _{BB} = 185 V Duty cycle = 0%	—	—	0.5	mA
	I _{CC}	V _{CC} = 15 V Duty cycle = 0%	—	1.8	10	
	I _{BS} (ON)	V _{BS} = 15 V, high side ON	—	210	470	
	I _{BS} (OFF)	V _{BS} = 15V, high side OFF	—	200	415	
Hall amp input sensitivity	VHSENS(HA)	—	50	—	—	mvp-p
Hall amp input current	IHB(HA)	—	-2	0	2	μA
Hall amp common input voltage	CMVIN(HA)	—	0	—	8	V
Hall amp hysteresis width	ΔVIN(HA)	—	20	30	50	mV
Hall amp input voltage L→H	VLH(HA)	—	5	15	25	
Hall amp input voltage H→L	VHL(HA)	—	-25	-15	-5	
Output saturation voltage	V _{CEsatH}	V _{CC} = 15 V, I _C = 0.5 A	—	2.3	3.0	V
	V _{CesatL}	V _{CC} = 15 V, I _C = 0.5 A	—	2.3	3.0	
FRD forward voltage	V _{FH}	I _F = 0.5 A, high side	—	1.4	2.1	V
	V _{FL}	I _F = 0.5 A, low side	—	1.4	1.8	
FRD forward voltage	V _F (BSD)	I _F = 500 μA	—	0.8	1.2	V
PWM ON-duty cycle	PWMMIN	—	0	—	—	%
	PWMMAX	—	—	—	100	
PWM ON-duty cycle, 0%	V _{V_S0%}	PWM = 0%	1.7	2.1	2.5	V
PWM ON-duty cycle, 100%	V _{V_S100%}	PWM = 100%	4.9	5.4	6.1	V
PWM ON-duty voltage range	V _{V_SW}	V _{V_S100%} – V _{V_S0%}	2.8	3.3	3.8	V
Output all-OFF voltage	V _{V_SOFF}	Output all OFF	1.1	1.3	1.5	V
Regulator voltage	V _{REG}	V _{CC} = 15 V, I _O = 30 mA	5	6	7	V
Speed control voltage range	V _S	—	0	—	6.5	V
FG output saturation voltage	V _{FGsat}	V _{CC} = 15 V, I _{FG} = 20 mA	—	—	0.5	V
Current control voltage	V _R	—	0.46	0.5	0.54	V
Thermal shutdown temperature	TSD	—	135	—	185	°C
Thermal shutdown hysteresis	ΔTSD	—	—	50	—	°C
V _{CC} under-voltage protection	V _{CCUVD}	—	10	11	12	V
V _{CC} under-voltage protection recovery	V _{CCUVR}	—	10.5	11.5	12.5	V
V _{BS} under-voltage protection	V _{BSUVD}	—	9	10	11	V
V _{BS} under-voltage protection recovery	V _{BSUVR}	—	9.5	10.5	11.5	V
Refresh operating ON voltage	T _{RFON}	Refresh operation	1.1	1.3	1.5	V
Refresh operating OFF voltage	T _{RFOFF}	Refresh operation OFF	3.1	3.8	4.6	V
Triangular wave frequency	f _c	R = 27 kΩ, C = 1000 pF	16.5	20	25	kHz
Output-on delay time	t _{on}	V _{BB} = 141 V, V _{CC} = 15 V, I _C = 0.5 A	—	1.8	3	μs
Output-off delay time	t _{off}	V _{BB} = 141 V, V _{CC} = 15 V, I _C = 0.5 A	—	1.2	3	μs
FRD reverse recovery time	t _{rr}	V _{BB} = 141V, V _{CC} = 15 V, I _C = 0.5 A	—	200	—	ns

Application Circuit Example

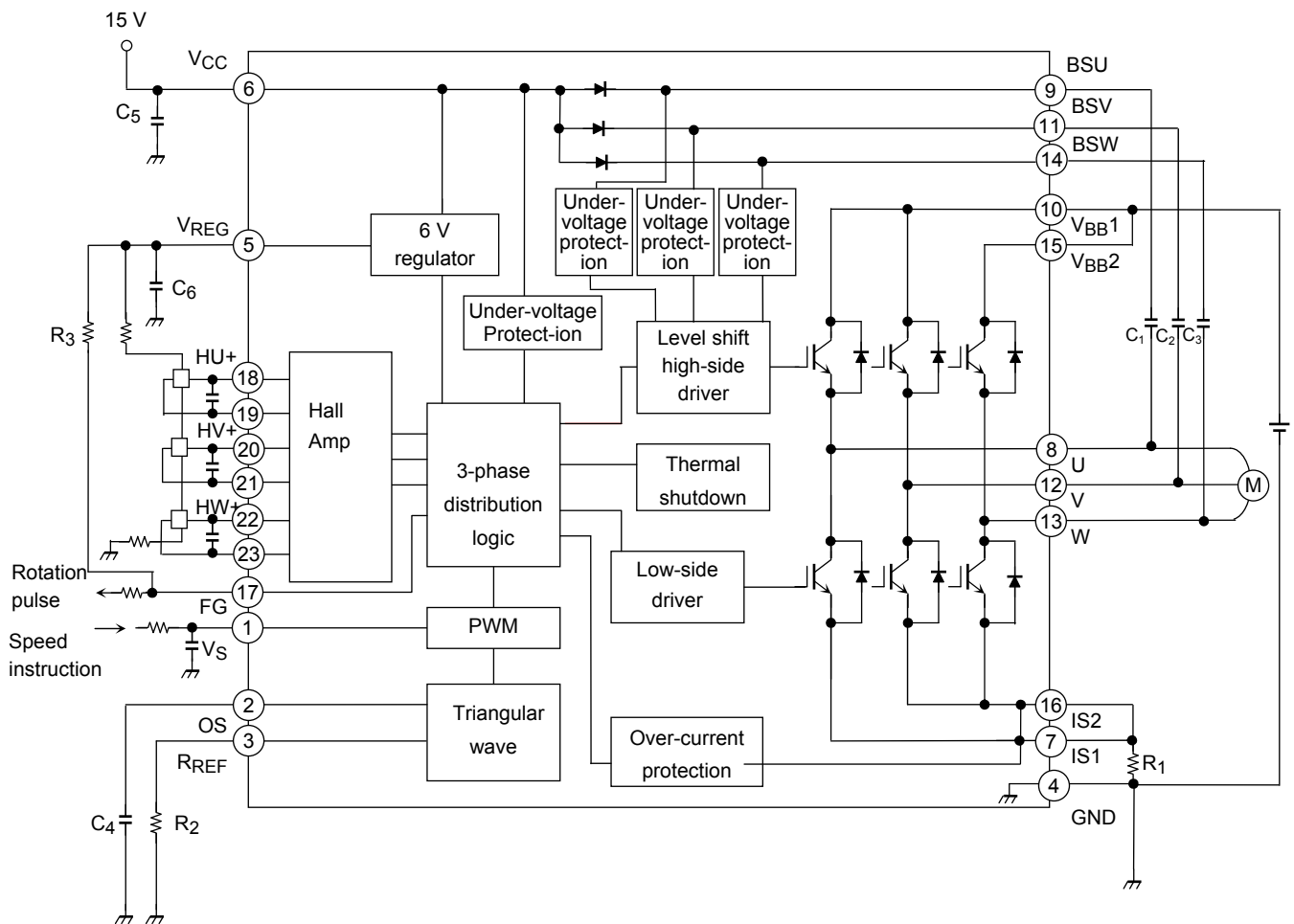

External Parts

Standard external parts are shown in the following table.

Part	Recommended Value	Purpose	Remarks
C ₁ , C ₂ , C ₃	25 V/2.2 μF	Bootstrap capacitor	(Note 1)
R ₁	0.62 Ω ± 1% (1 W)	Current detection	(Note 2)
C ₄	10 V/1000 pF ± 5%	PWM frequency setup	(Note 3)
R ₂	27 kΩ ± 5%	PWM frequency setup	(Note 3)
C ₅	25 V/10 μF	Control power supply stability	(Note 4)
C ₆	10 V/0.1 μF	V _{REG} power supply stability	(Note 4)
R ₃	5.1 kΩ	FG pin pull-up resistor	(Note 5)

Note 1: The required bootstrap capacitance value varies according to the motor drive conditions. Although the IC can operate at above the V_{BS} undervoltage level, it is however recommended that the capacitor voltage be greater than or equal to 13.5 V to keep the power dissipation small. The capacitor is biased by V_{CC} and must be sufficiently derated accordingly.

Note 2: The following formula shows the detection current: $I_O = V_R \div R_1$ (V_R = 0.5 V typ.)
Do not exceed a detection current of 1 A when using the IC.

Note 3: With the combination of C_{OS} and R_{REF} shown in the table, the PWM frequency is around 20 kHz. The IC intrinsic error factor is around 10%.

The PWM frequency is broadly expressed by the following formula. (In this case, the stray capacitance of the printed circuit board needs to be considered.)

$$f_{\text{PWM}} = 0.65 \div \{C_{\text{OS}} \times (R_{\text{REF}} + 4.25 \text{ k}\Omega)\} \quad [\text{Hz}]$$

R_{REF} creates the reference current of the PWM triangular wave charge/discharge circuit. If R_{REF} is set too small it exceeds the current capacity of the IC internal circuits and the triangular wave distorts. Set R_{REF} to at least 9 kΩ.

Note 4: When using the IC, some adjustment is required in accordance with the use environment. When mounting, place as close to the base of the IC leads as possible to improve noise elimination.

Note 5: The FG pin is open drain. Note that when the FG pin is connected to a power supply with a voltage higher than or equal to the V_{CC}, a protection circuit is triggered so that the current flows continuously. If the FG pin is not used, connect to the GND.

Note 6: If noise is detected on the Input signal pin, add a capacitor between inputs.

Note 7: A Hall device should use an indium antimony system.

Handling precautions

- (1) When switching the power supply to the circuit on/off, ensure that V_S < VV_SOFF (all IGBT outputs off). At that time, either the V_{CC} or the V_{BB} can be turned on/off first. Note that if the power supply is switched off as described above, the IC may be destroyed if the current regeneration route to the V_{BB} power supply is blocked when the V_{BB} line is disconnected by a relay or similar while the motor is still running.
- (2) The triangular wave oscillator circuit, with externally connected C_{OS} and R_{REF}, charges and discharges minute amounts of current. Therefore, subjecting the IC to noise when mounting it on the board may distort the triangular wave or cause malfunction. To avoid this, attach external parts to the base of the IC leads or isolate them from any tracks or wiring which carries large current.
- (3) The PWM of this IC is controlled by the on/off state of the high-side IGBT.
- (4) If a motor is locked where V_{BB} voltage is low and duty is 100%, it may not be possible to reboot after the load is released as a result of the high side being ON immediately prior to the motor being locked. This is because, over time, the bootstrap voltage falls, the high-side voltage decrease protection operates and the high-side output becomes OFF. In this case, since the level shift pulse necessary to turn the high side ON cannot be generated, reboot is not possible. A level shift pulse is generated by either the edge of a Hall sensor output or the edge of an internal PWM signal, but neither edge is available due to the motor lock and duty 100% command. In order to reboot after a lock, the high-side power voltage must return to a level 0.5V (typ.) higher than the voltage decrease protection level, and a high-side input signal must be introduced. As a high-side input signal is created by the aforementioned level shift pulse, it is possible to reboot by reducing PWM duty to less than 100% or

by forcing the motor to turn externally and creating an edge at a Hall sensor output. In order to ensure reboot after a system lock, the motor specification must be such that maximum duty is less than 100%.

Description of Protection Function

(1) Over-current protection

The IC incorporates an over-current protection circuit to protect itself against over current at startup or when a motor is locked. This protection function detects voltage generated in the current-detection resistor connected to the IS1/IS2 pin. When this voltage exceeds $V_R = 0.5 \text{ V}$ (typ.), the high-side IGBT output, which is on, temporarily shuts down after a mask period, preventing any additional current from flowing to the IC. The next PWM ON signal releases the shutdown state.

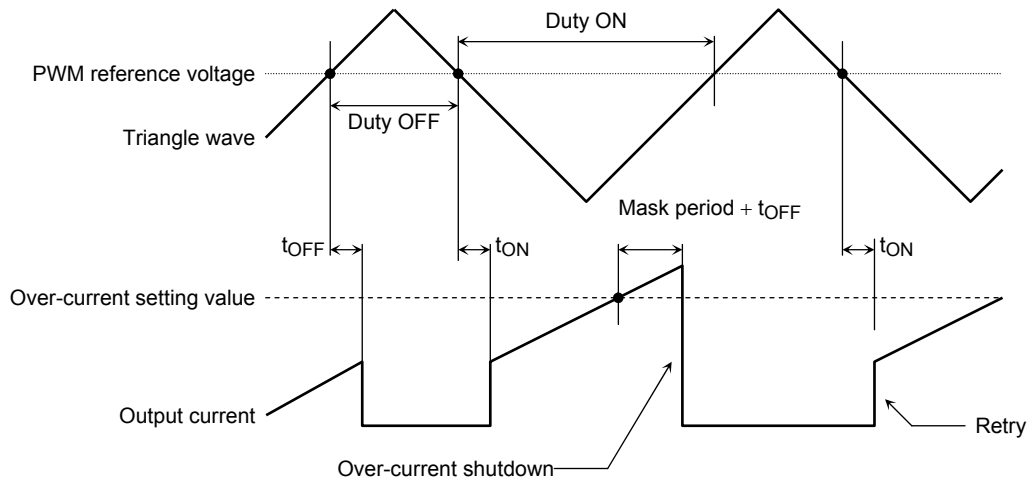

(2) Under-voltage protection

The IC incorporates an under-voltage protection circuit to prevent the IGBT from operating in unsaturated mode when the V_{CC} voltage or the V_{BS} voltage drops.

When the V_{CC} power supply falls to the IC internal setting ($V_{CCUVD} = 11 \text{ V}$ typ.), all IGBT outputs shut down regardless of the input. This protection function has hysteresis. When the V_{CCUVR} ($= 11.5 \text{ V}$ typ.) reaches 0.5 V higher than the shutdown voltage, the IC is automatically restored and the IGBT is turned on/off again by the input.

When the V_{BS} supply voltage drops ($V_{BSUVD} = 10 \text{ V}$ typ.), the high-side IGBT output shuts down. When the V_{BSUVR} ($= 10.5 \text{ V}$ typ.) reaches 0.5 V higher than the shutdown voltage, the IGBT is turned on/off again by the input signal.

(3) Thermal shutdown

The IC incorporates a thermal shutdown circuit to protect itself against excessive rise in temperature. When the temperature of this chip rises to the internal setting T_{SD} due to external causes or internal heat generation, all IGBT outputs shut down regardless of the input. This protection function has hysteresis ($\Delta T_{SD} = 50^\circ\text{C}$ typ.). When the chip temperature falls to $T_{SD} - \Delta T_{SD}$, the chip is automatically restored and the IGBT is turned on/off again by the input.

Because the chip contains just one temperature-detection location, when the chip heats up due to the IGBT for example, the distance between the detection location and the IGBT (the source of the heat) can cause differences in the time taken for shutdown to occur. Therefore, the temperature of the chip may rise higher than the initial thermal shutdown temperature.

Description of Bootstrap Capacitor Charging and Its Capacitance

The IC uses bootstrapping for the power supply for high-side drivers. The bootstrap capacitor is charged by turning on the low-side IGBT of the same arm (approximately 1/5 of PWM cycle) while the high-side IGBT controlled by PWM is off. (For example, to drive at 20 kHz, it takes approximately 10 ms per cycle to charge the capacitor.) When the VS voltage exceeds 3.8 V (55% duty), the low-side IGBT is continuously in the off state. This is because when the PWM on-duty becomes larger, the arm is short-circuited while the low-side IGBT is on. Even in this state, because PWM control is being performed on the high-side IGBT, the regenerative current of the diode flows to the low-side FRD of the same arm, and the bootstrap capacitor is charged. Note that when the on-duty is 100%, diode regenerative current does not flow; thus, the bootstrap capacitor is not charged. When driving a motor at 100 % duty cycle, take the voltage drop at 100% duty (see the figure below) into consideration to determine the capacitance of the bootstrap capacitor.

Capacitance of the bootstrap capacitor = Consumption current (max) of the high-side driver × Maximum drive time / (VCC - VF (BSD) + VF (FRD) - 13.5) [F]

VF (BSD) : Bootstrap diode forward voltage

VF (FRD) : Flywheel diode forward voltage

Consideration must be made for aging and temperature change of the capacitor.

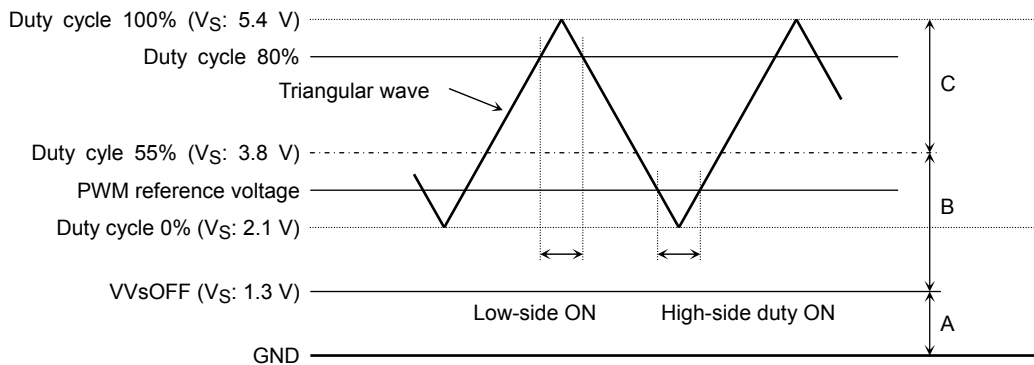

V _S Range	IGBT Operation
A	Both high- and low-side OFF.
B	Charging range. Low-side IGBT refreshing on the phase the high-side IGBT in PWM.
C	No charging range. High-side at PWM according to the timing chart. Low-side no refreshing.

Safe Operating Area

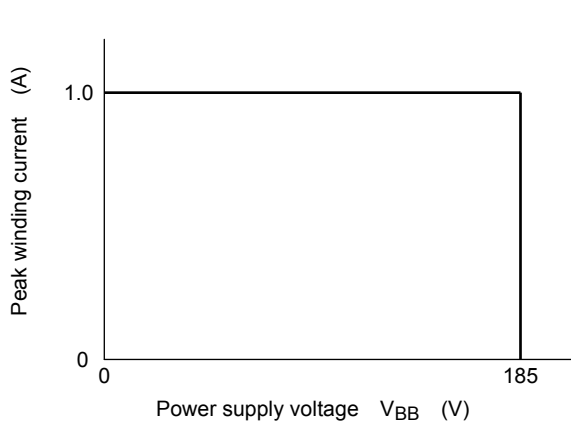

Figure 1 SOA at Tj = 135°C

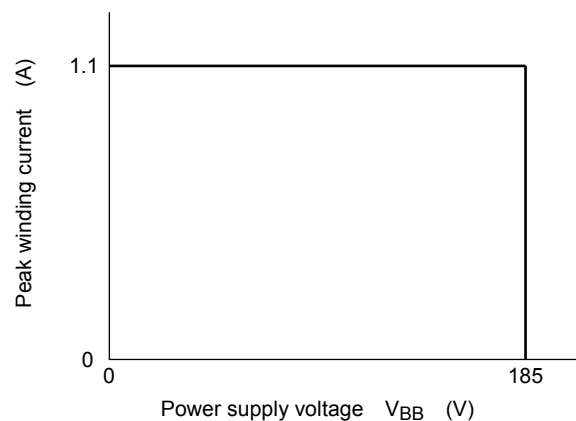
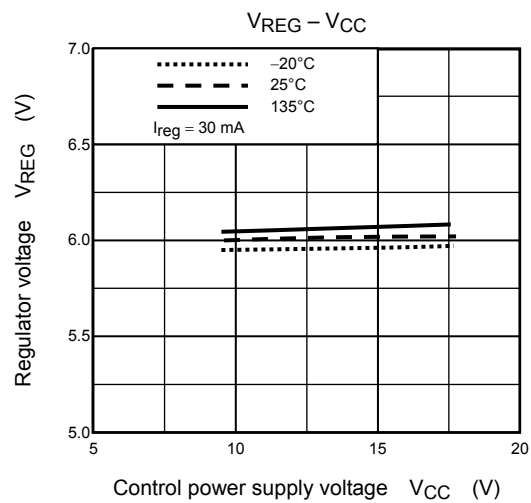
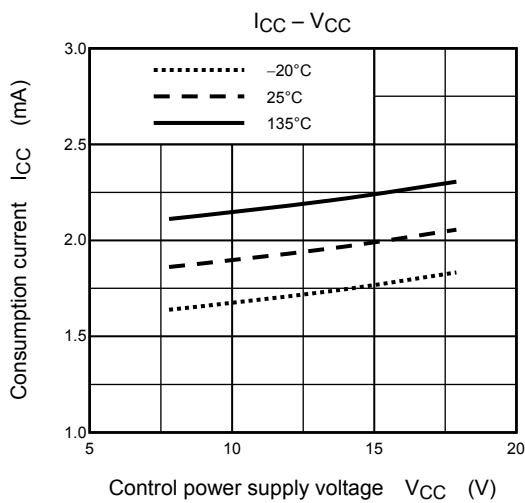
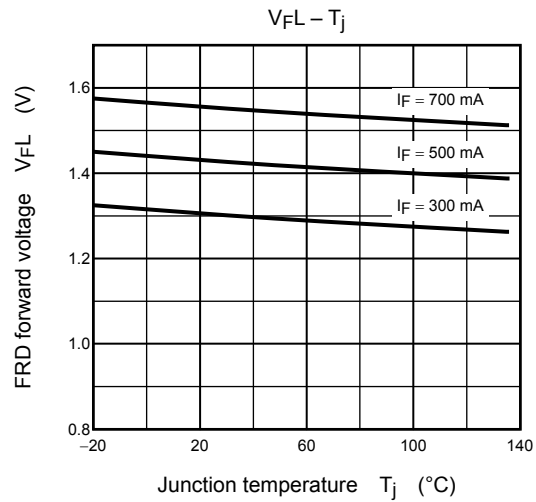
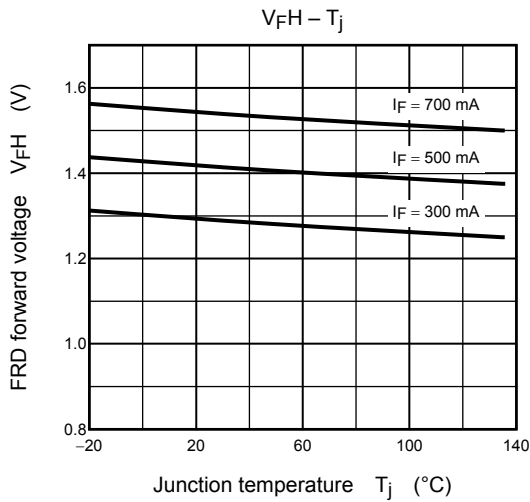
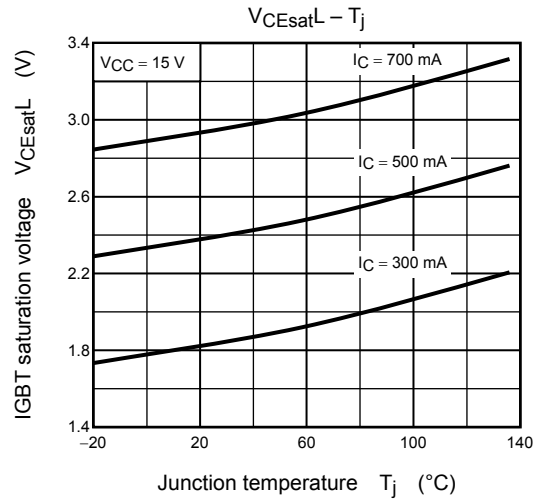
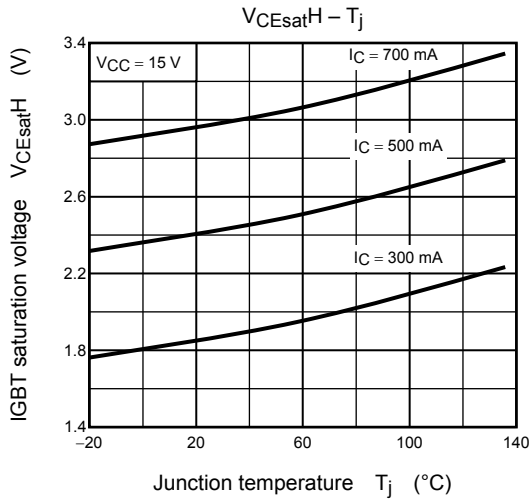
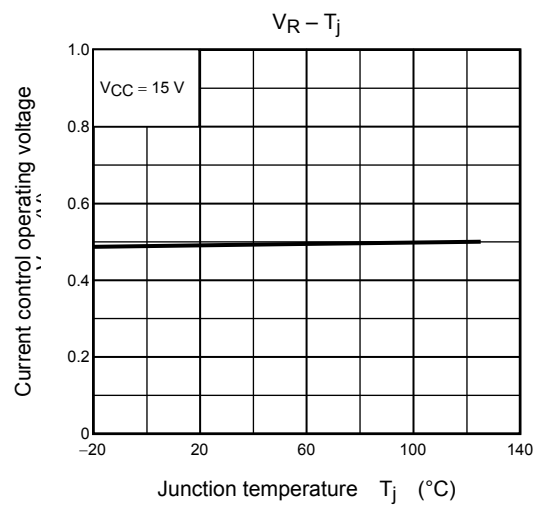
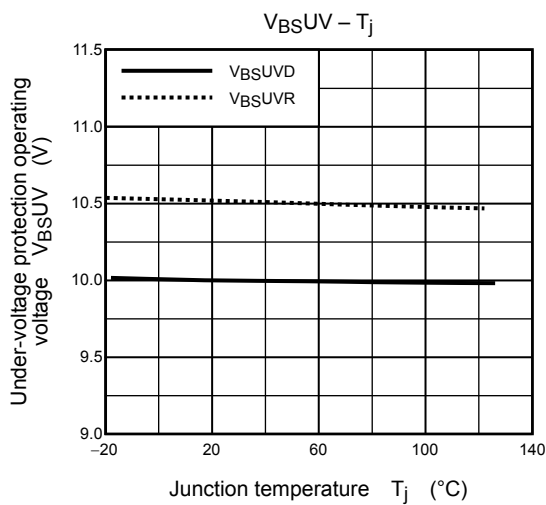
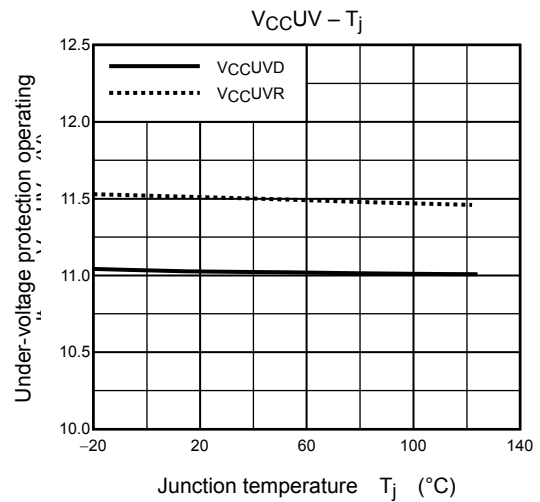
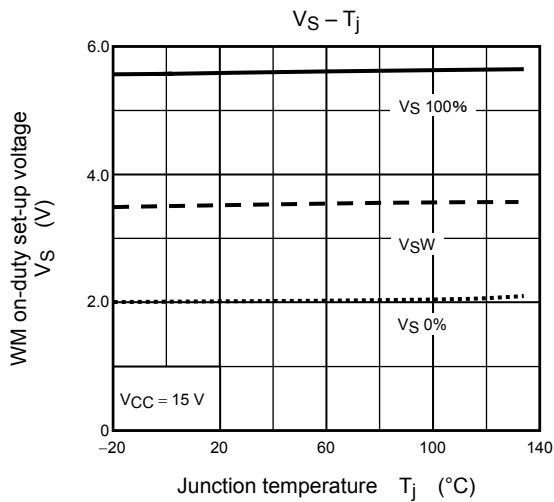
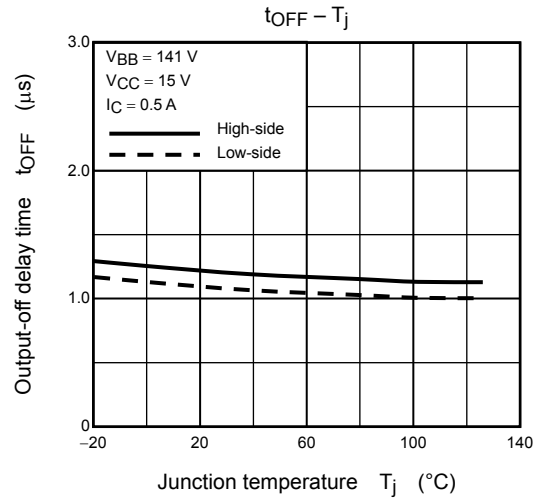
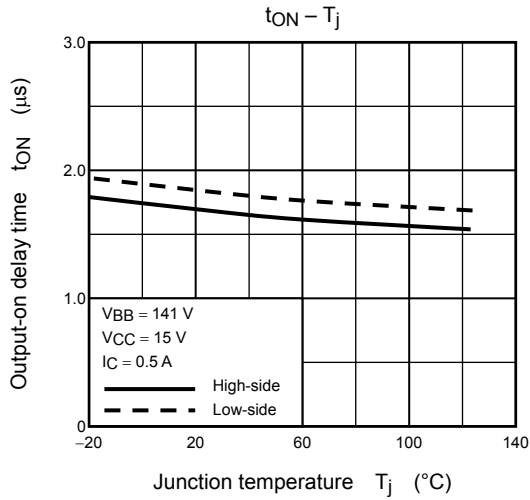

Figure 2 SOA at Tc = 95°C

Note 1: The above safe operating areas are at Tj = 135°C (Figure 1) and Tc = 95°C (Figure 2). If the temperature exceeds these, the safe operation areas are reduced.

Note 2: The above safe operating areas include the over-current protection operation area.





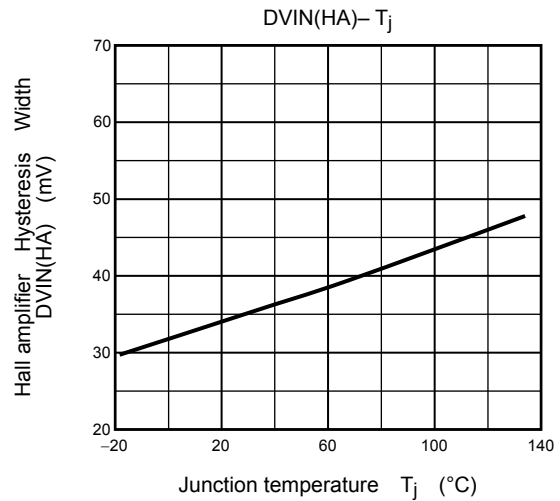
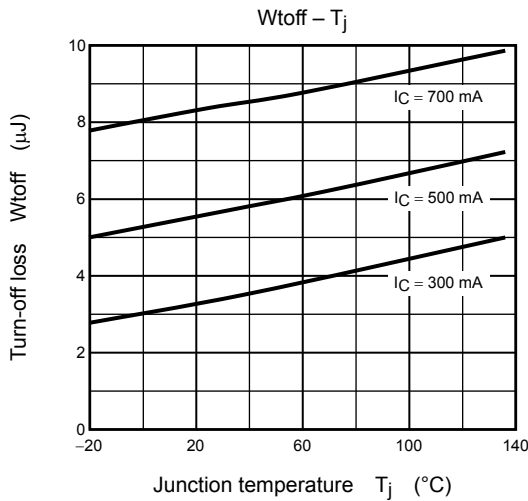
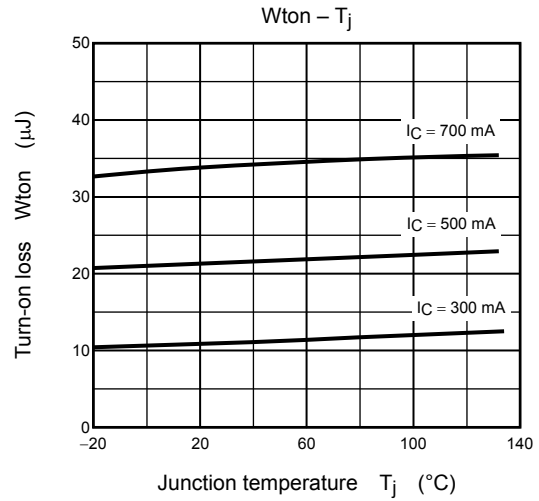
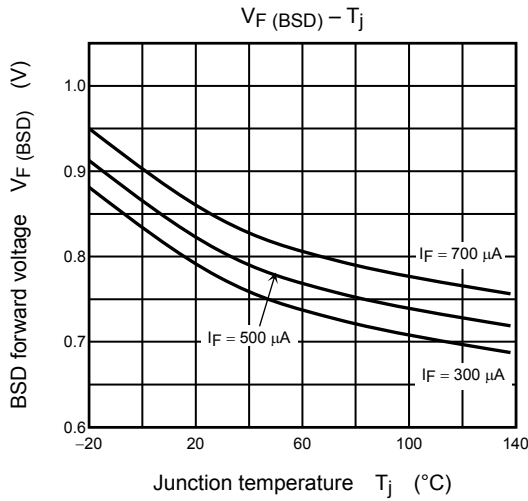
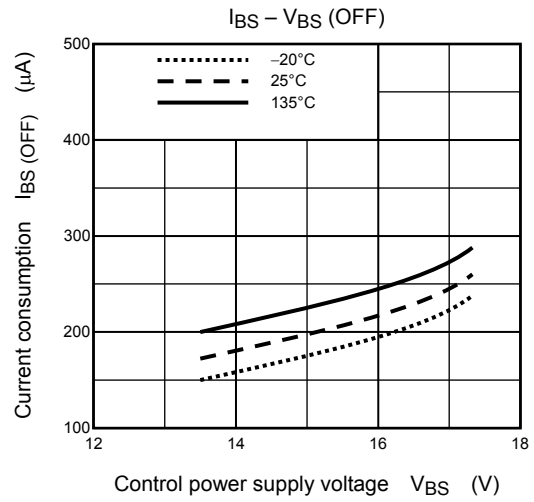
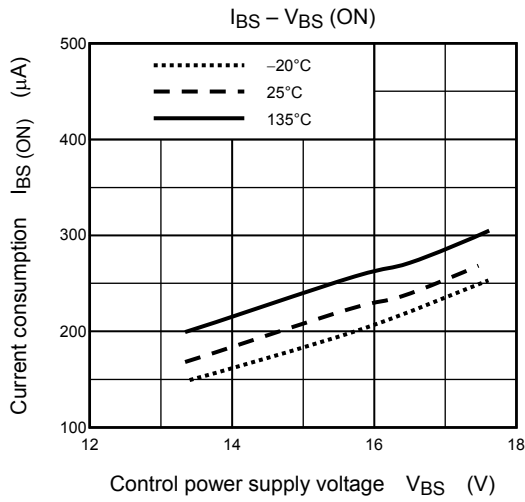

Test Circuits

IGBT Saturation Voltage (U-phase low side)

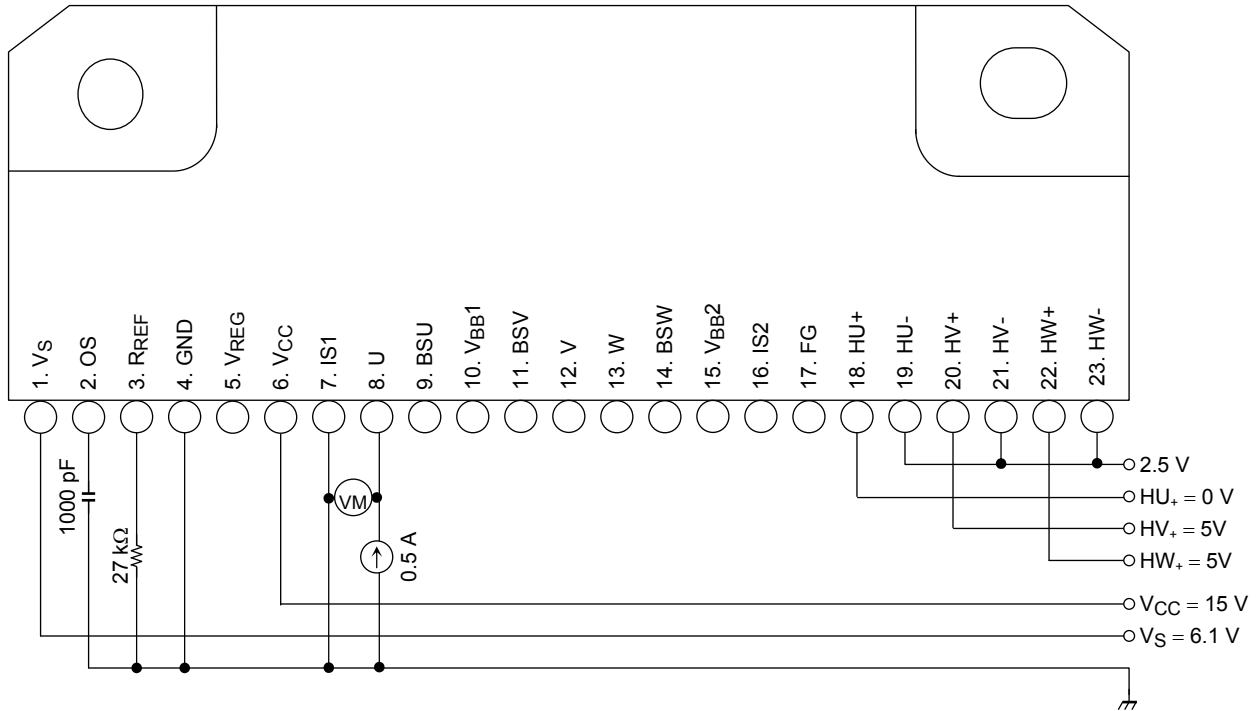

FRD Forward Voltage (U-phase low side)

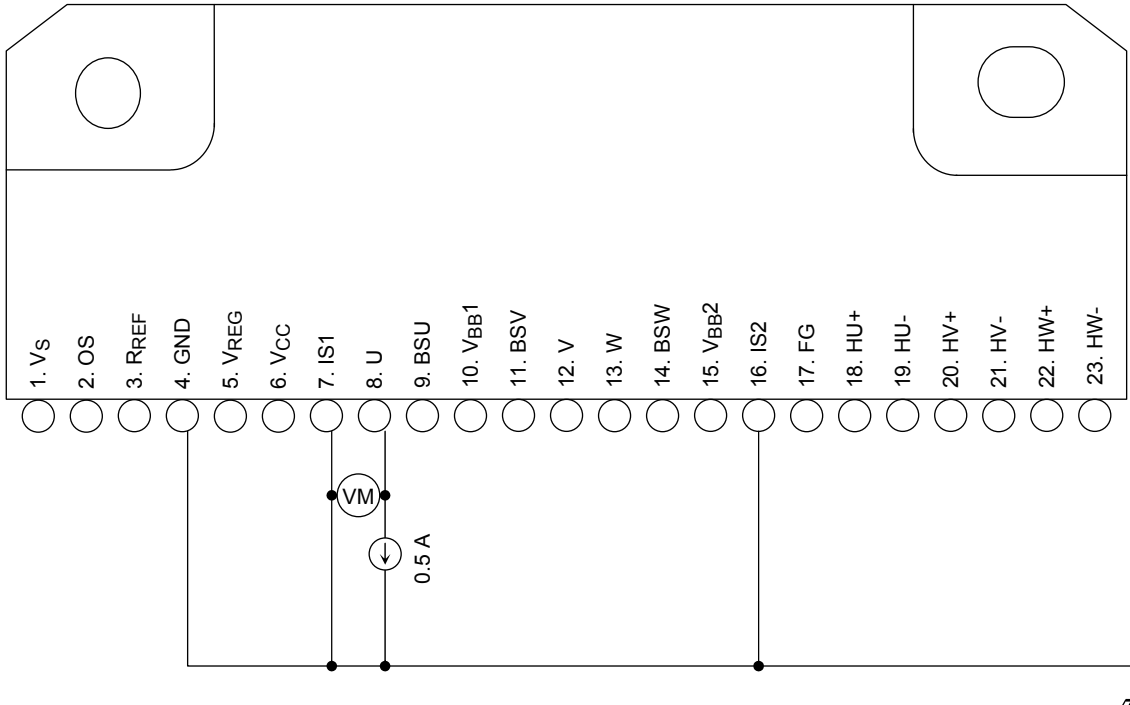

V_{CC} Current Dissipation

www.DataSheet4U.com

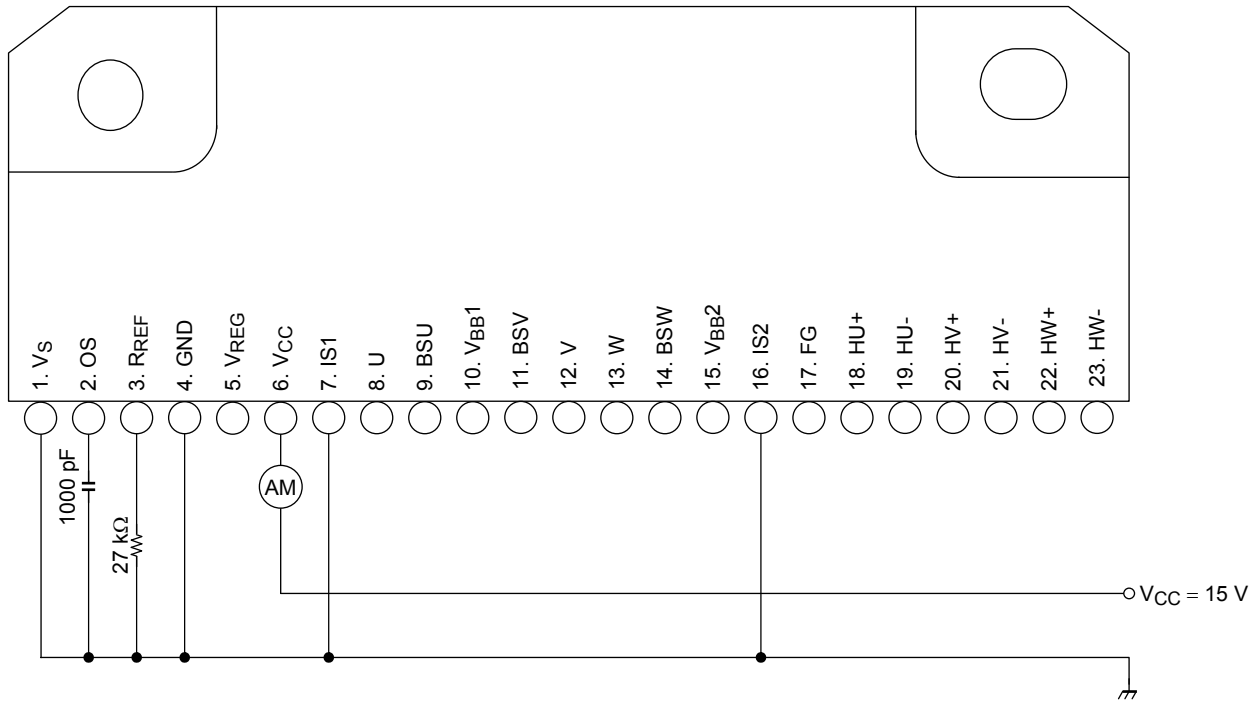

Regulator Voltage

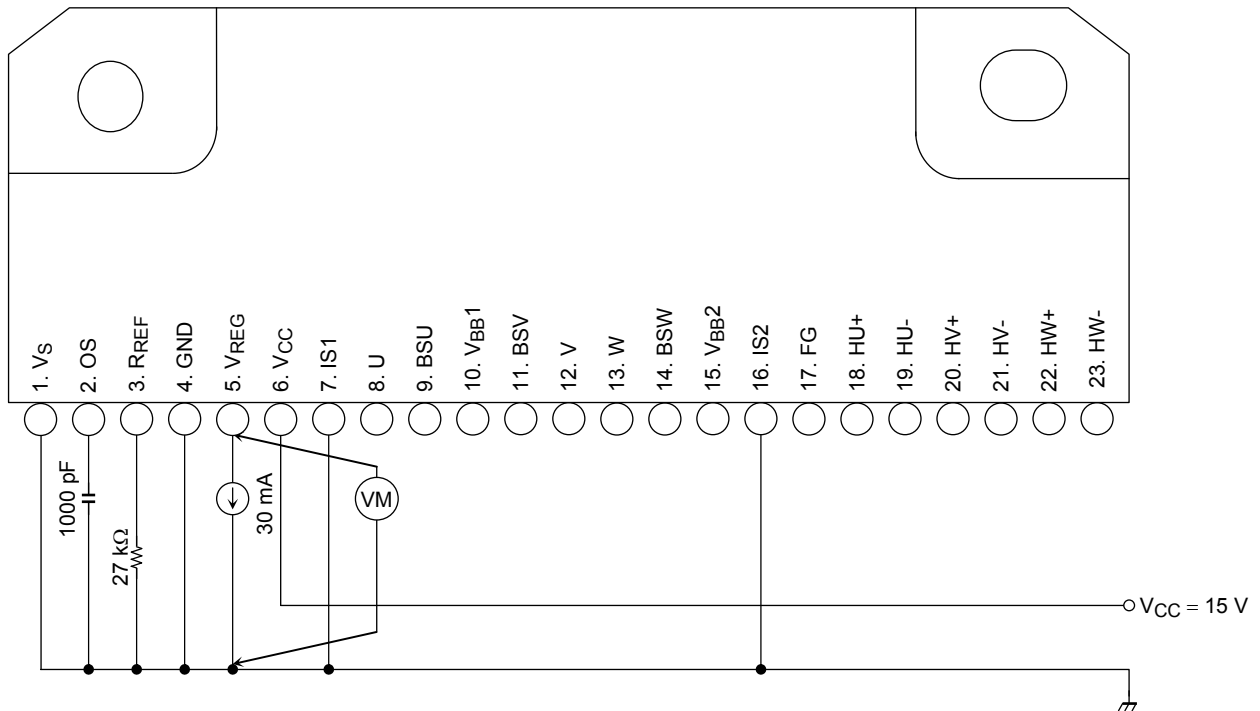

Output ON/OFF Delay Time (U-phase low side)

www.DataSheet4U.com

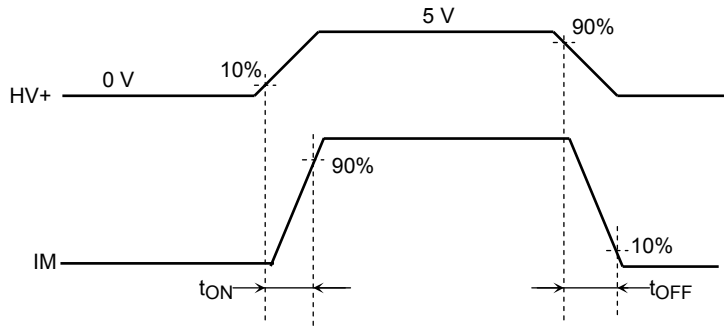
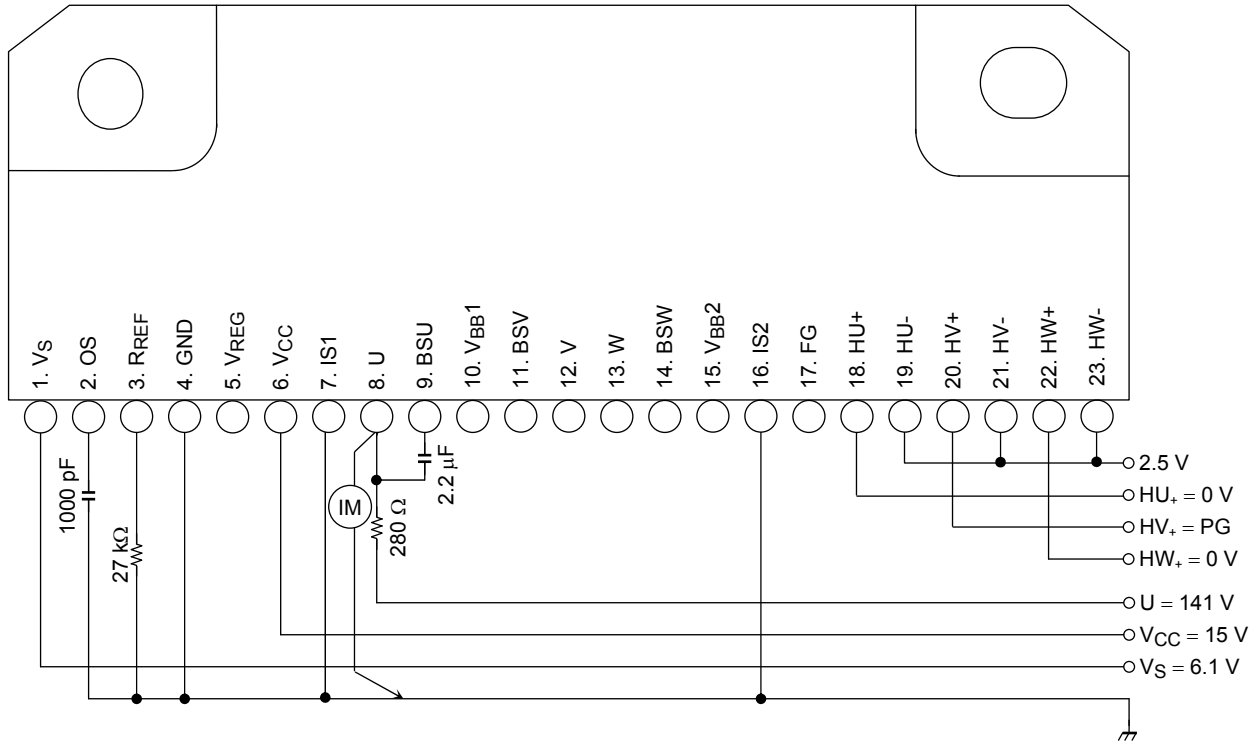

PWM ON-duty Setup Voltage (U-phase high side)

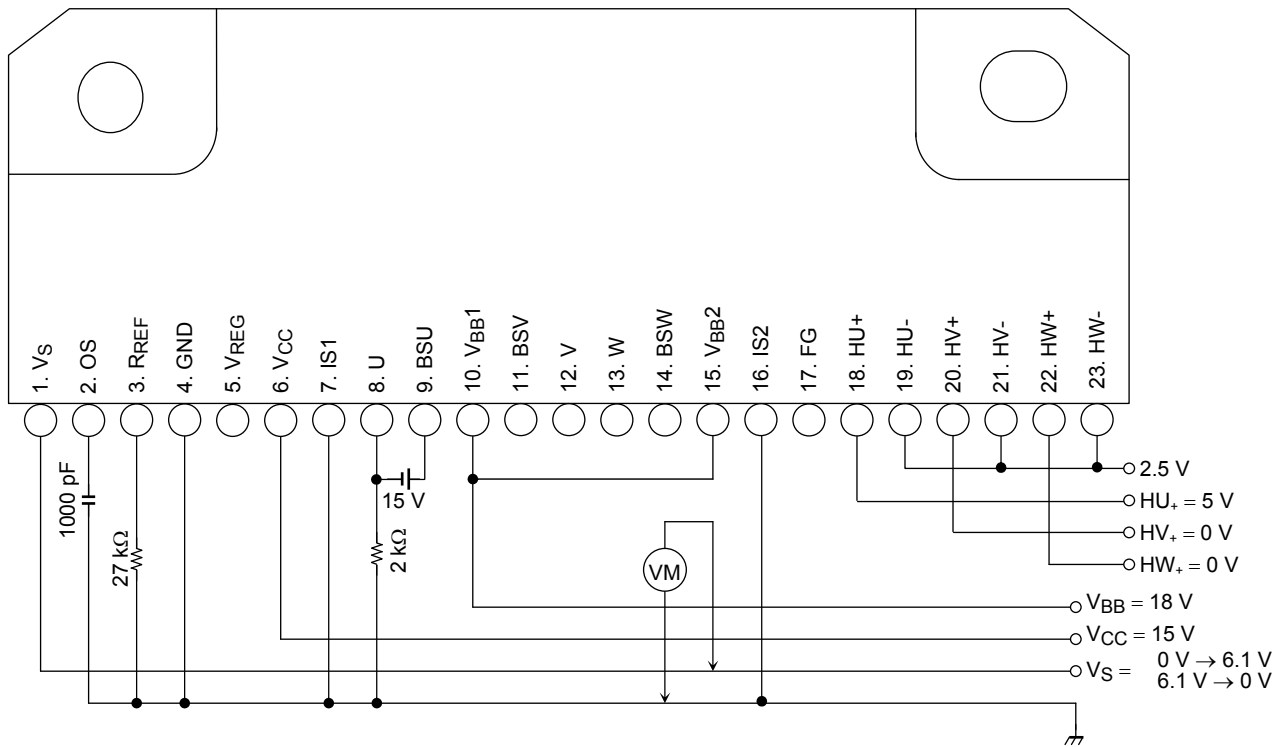

Note: Sweeps the VS pin voltage and monitors the U pin.
 When output is turned off from on, the PWM = 0%. When output is full on, the PWM = 100%.

VCC Under-voltage Protection Operation/Recovery Voltage (U-phase low side)

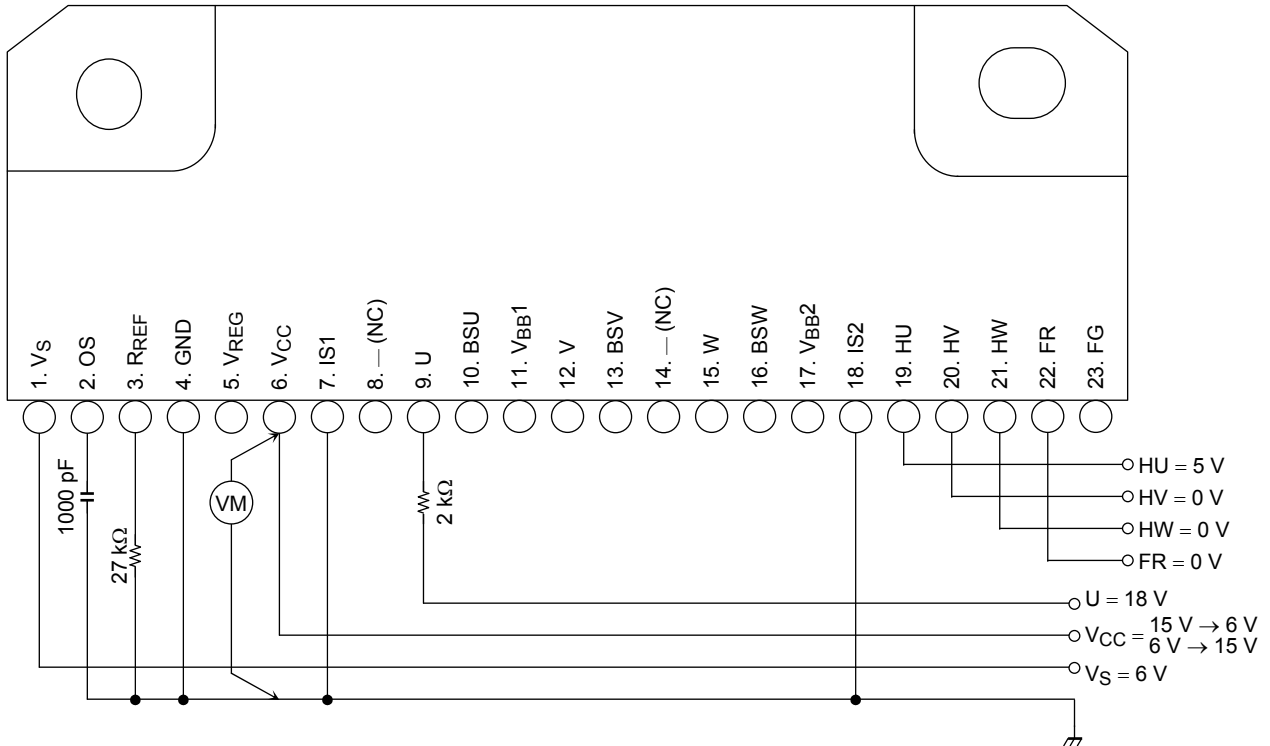

Note: Sweeps the VCC pin voltage from 15 V and monitors the U pin voltage.
 The VCC pin voltage when output is off defines the under-voltage protection operating voltage.
 Also sweeps from 6 V to increase. The VCC pin voltage when output is on defines the under voltage protection recovery voltage.

VBS Under-voltage Protection Operation/Recovery Voltage (U-phase high side)

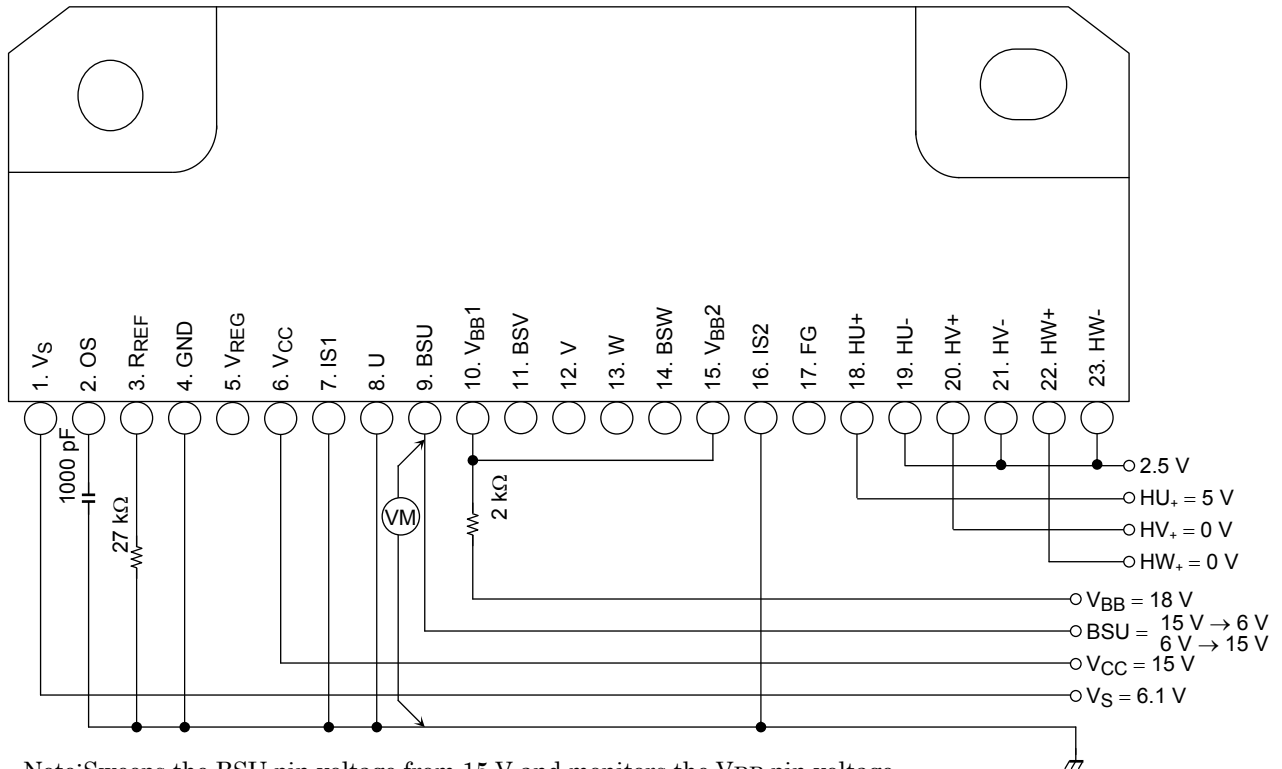

Note: Sweeps the BSU pin voltage from 15 V and monitors the VBB pin voltage.
 The BSU pin voltage when output is off defines the under-voltage protection operating voltage.
 Also sweeps the BSU pin voltage from 6 V and changes the VS voltage from 6 V → 0 V → 6V. The BSU pin voltage when output is on defines the under-voltage protection recovery voltage.

Current Control Operating Voltage (U-phase high side)

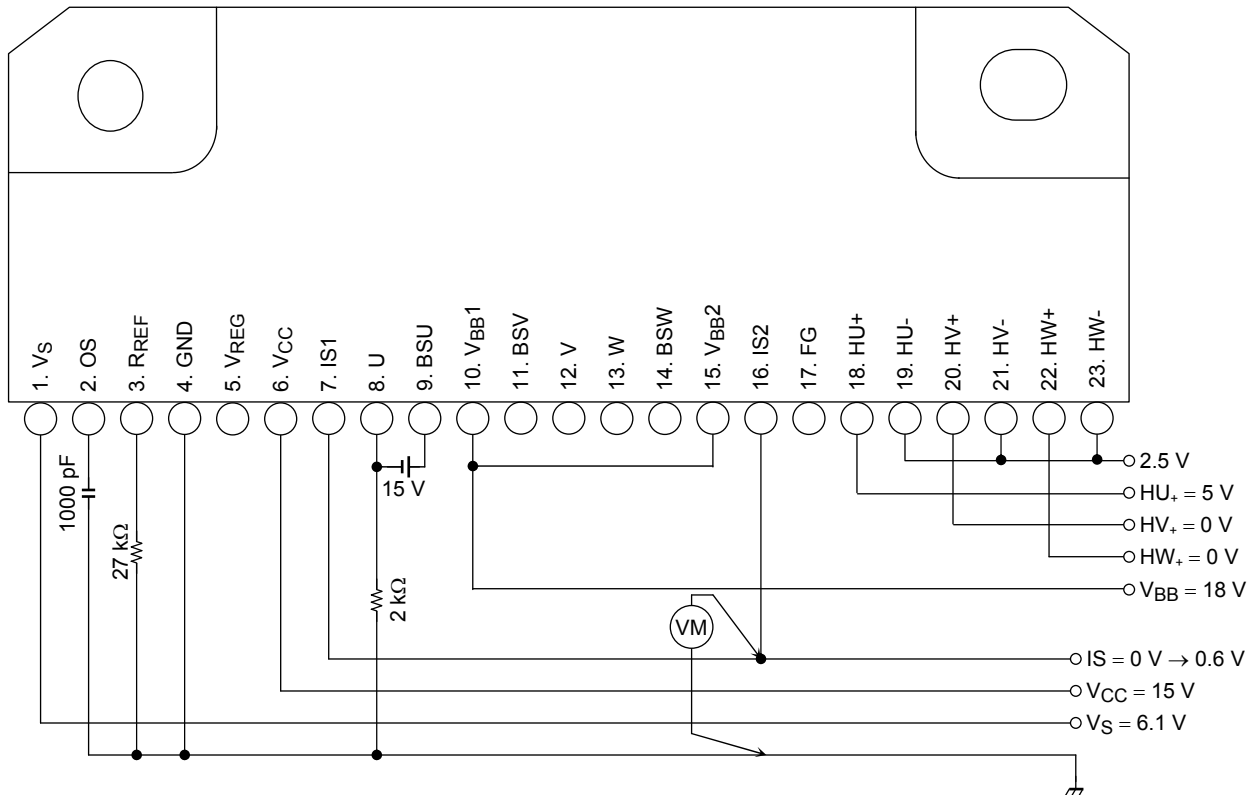

Note: Sweeps the IS pin voltage and monitors the U pin voltage.

The IS pin voltage when output is off defines the current control operating voltage.

V_{BS} Current Consumption (U-phase high side)

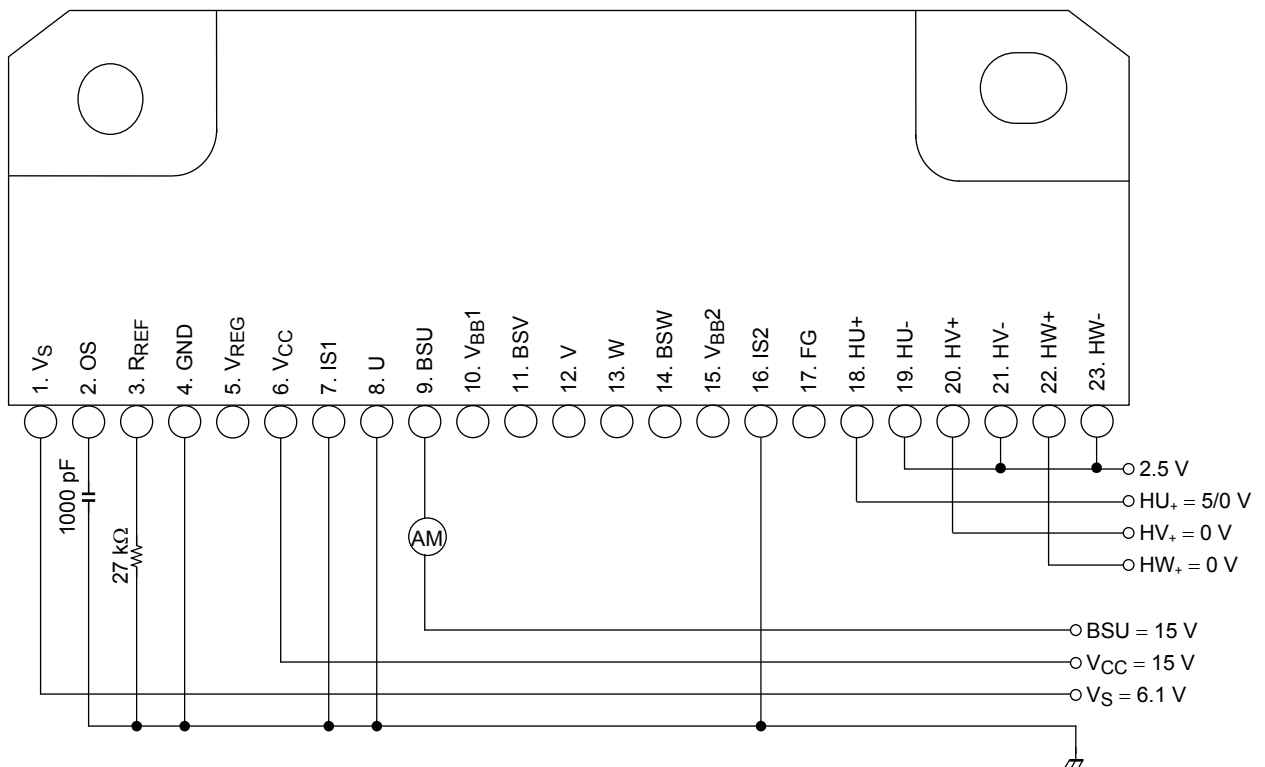

BSD Forward Voltage (U-phase)

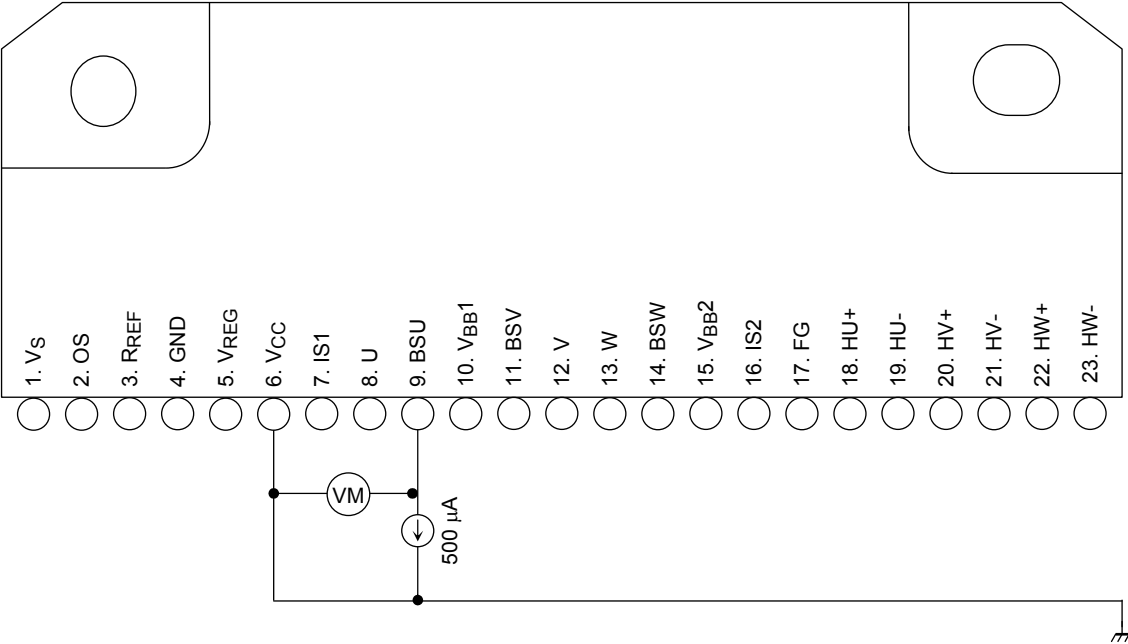

Turn-On/Off Loss (low-side IGBT + high-side FRD)

www.DataSheet4U.com

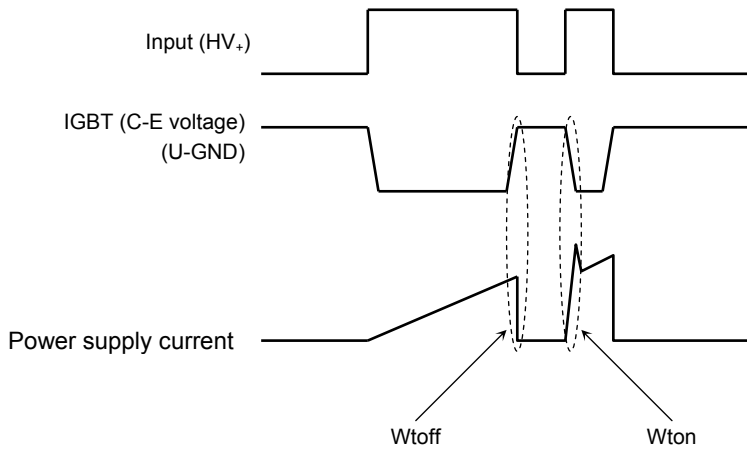
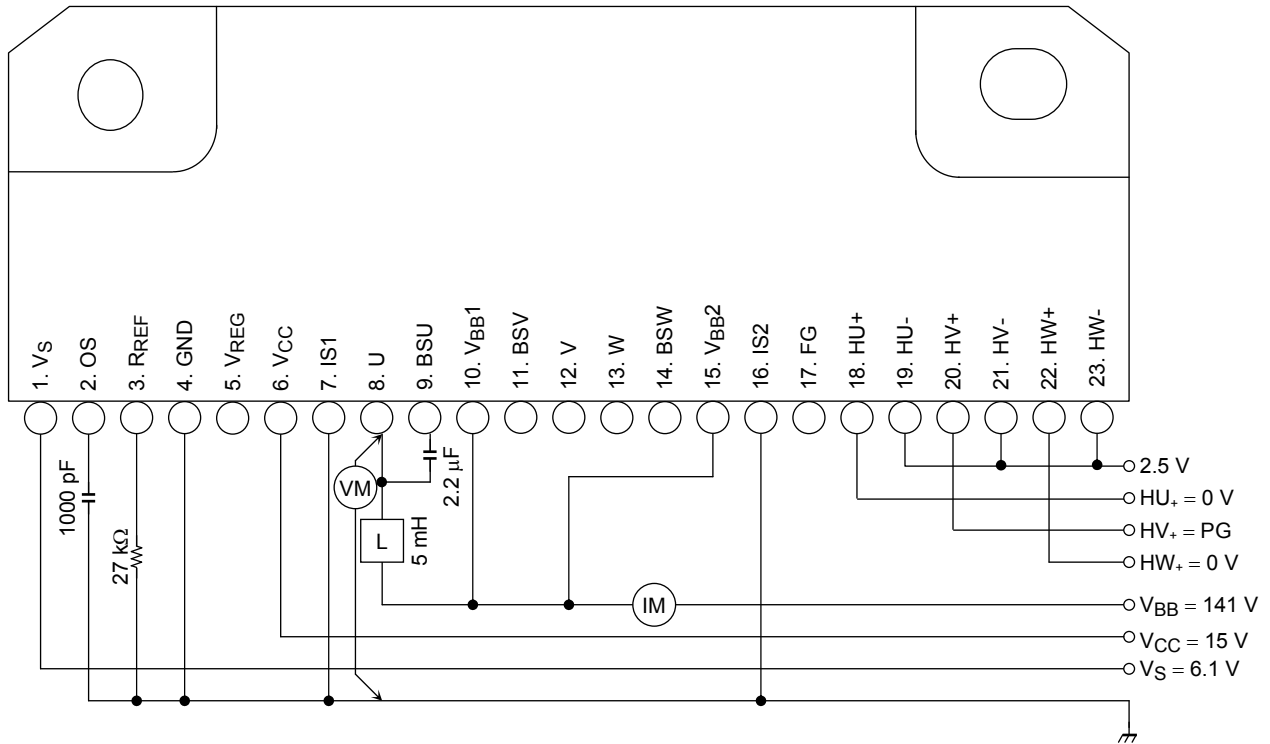

Package Dimensions

HZIP23-P-1.27F

Unit: mm

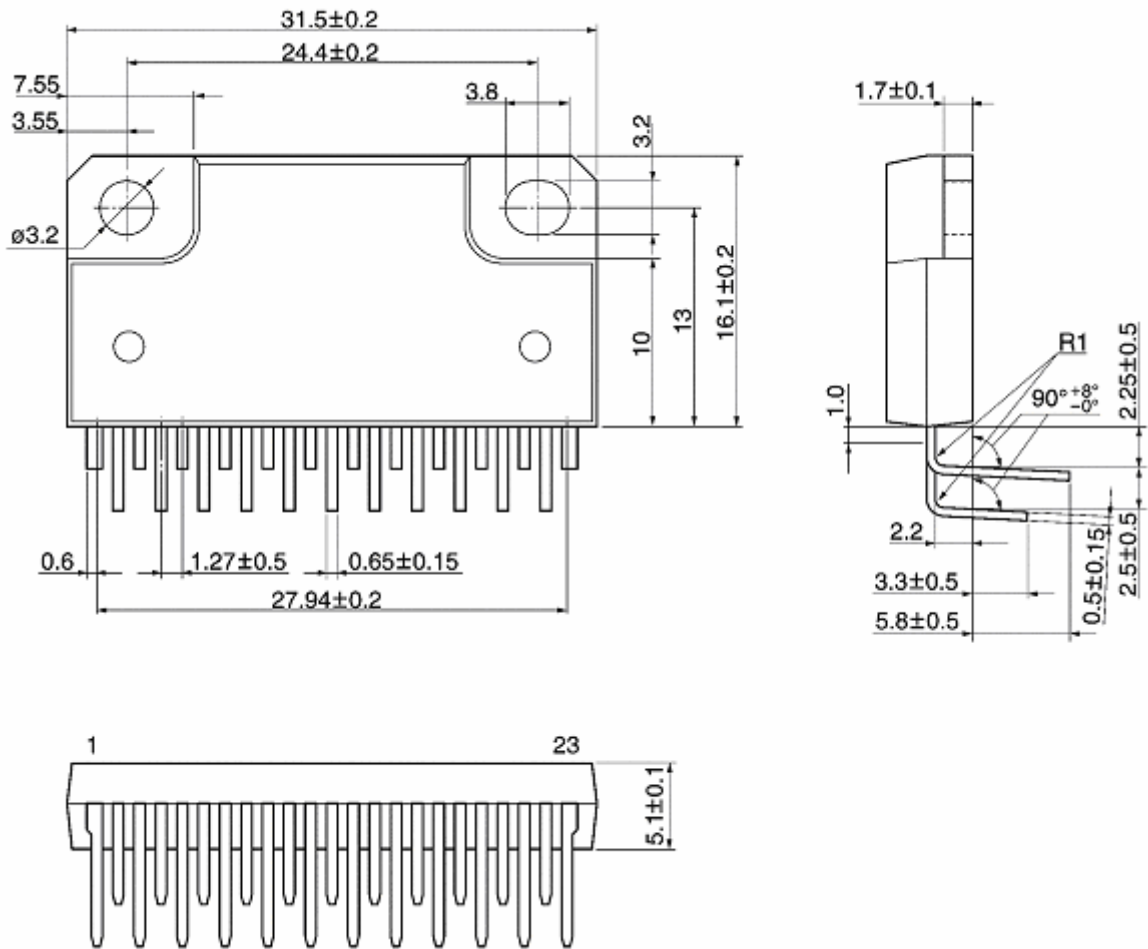

Weight: 6.1 g (typ.)

Package Dimensions

HZIP23-P-1.27G

Unit: mm

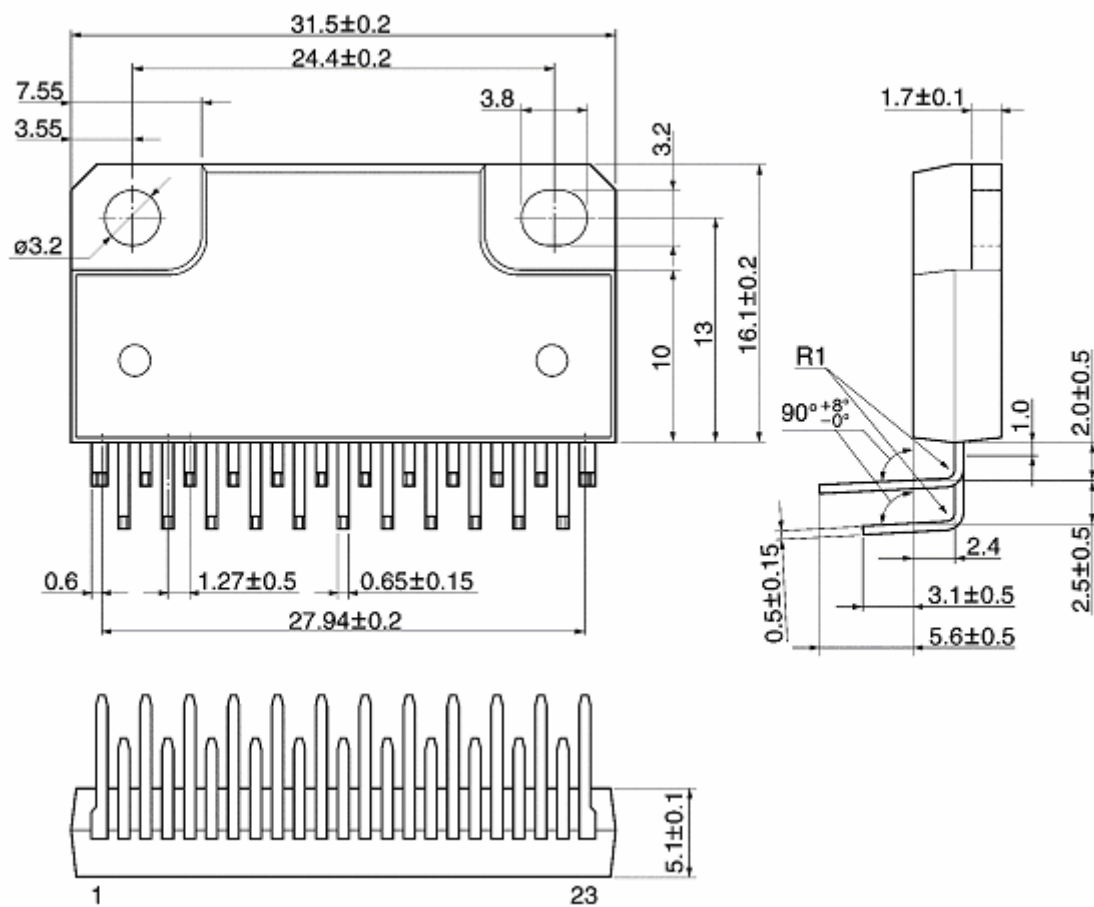

Weight: 6.1 g (typ.)

Package Dimensions

HZIP23-P-1.27H

Unit: mm

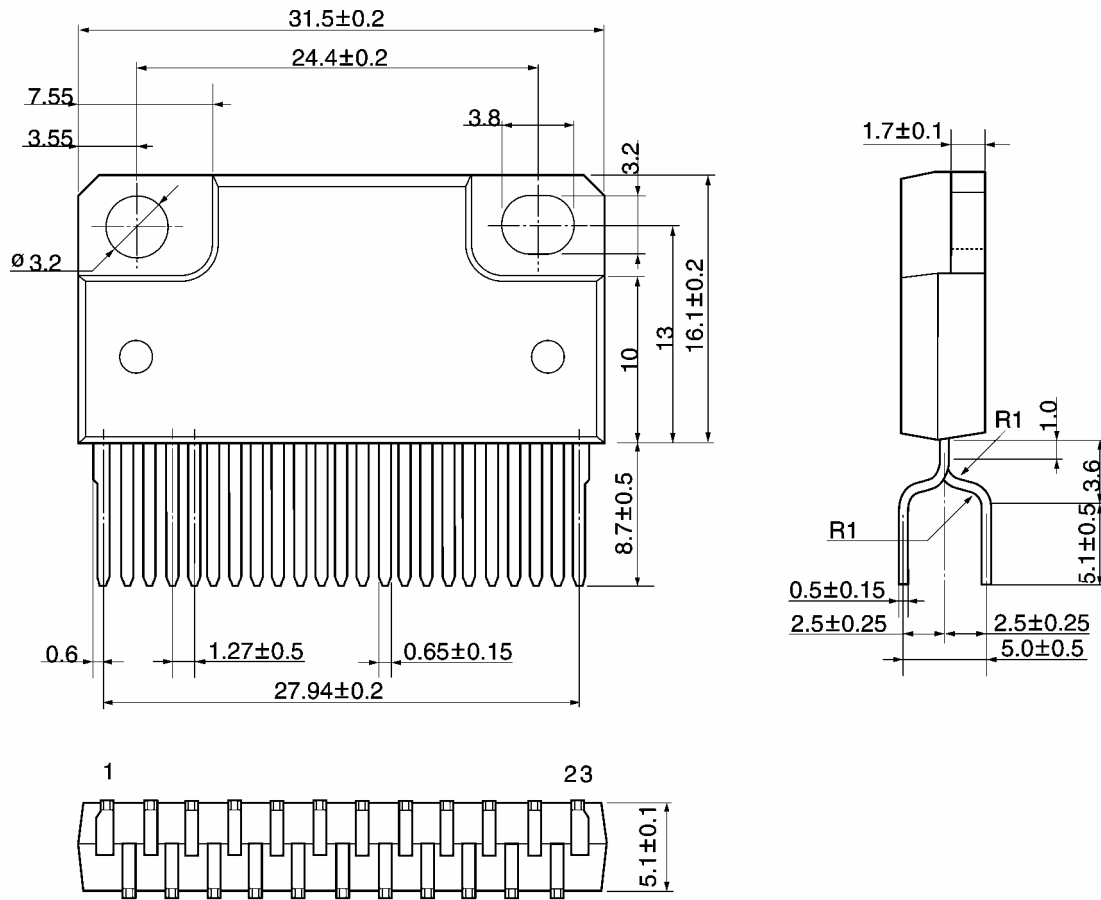

Weight: 6.1 g (typ.)

RESTRICTIONS ON PRODUCT USE

20070701-EN

- The information contained herein is subject to change without notice.
- TOSHIBA is continually working to improve the quality and reliability of its products. Nevertheless, semiconductor devices in general can malfunction or fail due to their inherent electrical sensitivity and vulnerability to physical stress. It is the responsibility of the buyer, when utilizing TOSHIBA products, to comply with the standards of safety in making a safe design for the entire system, and to avoid situations in which a malfunction or failure of such TOSHIBA products could cause loss of human life, bodily injury or damage to property.
In developing your designs, please ensure that TOSHIBA products are used within specified operating ranges as set forth in the most recent TOSHIBA products specifications. Also, please keep in mind the precautions and conditions set forth in the "Handling Guide for Semiconductor Devices," or "TOSHIBA Semiconductor Reliability Handbook" etc.
- The TOSHIBA products listed in this document are intended for usage in general electronics applications (computer, personal equipment, office equipment, measuring equipment, industrial robotics, domestic appliances, etc.). These TOSHIBA products are neither intended nor warranted for usage in equipment that requires extraordinarily high quality and/or reliability or a malfunction or failure of which may cause loss of human life or bodily injury ("Unintended Usage"). Unintended Usage include atomic energy control instruments, airplane or spaceship instruments, transportation instruments, traffic signal instruments, combustion control instruments, medical instruments, all types of safety devices, etc.. Unintended Usage of TOSHIBA products listed in this document shall be made at the customer's own risk.
- The products described in this document shall not be used or embedded to any downstream products of which manufacture, use and/or sale are prohibited under any applicable laws and regulations.
- The information contained herein is presented only as a guide for the applications of our products. No responsibility is assumed by TOSHIBA for any infringements of patents or other rights of the third parties which may result from its use. No license is granted by implication or otherwise under any patents or other rights of TOSHIBA or the third parties.
- Please contact your sales representative for product-by-product details in this document regarding RoHS compatibility. Please use these products in this document in compliance with all applicable laws and regulations that regulate the inclusion or use of controlled substances. Toshiba assumes no liability for damage or losses occurring as a result of noncompliance with applicable laws and regulations.