



DESCRIPTION: 1W 3KVDC Isolation & Regulated Dual Output DC-DC Converters

TPI series are specially designed for 3KVDC isolation & regulated dual output application, the input voltage range within $\pm 5\%$, 3KVDC isolation and regulated output with very low ripple noise.

FEATURES

Small footprint	3KVDC isolation	Regulated dual output
Operating temperature: -40°C to 105°C	Industry standard pinout	Internal SMD construction
Continuous short circuit protection	No external component Required	RoHS compliance, CE certification

SELECTION GUIDE

Part Number	Nominal Input Voltage	Input voltage range	Output voltage	Output current(Max)	Output current(Min)	Efficiency	Package Style
	VDC	VDC	VDC	mA	mA	%, Typ.	
TPI0505S	5	4.75-5.25	± 5	± 100	± 10	54	SIP
TPI0509S	5	4.75-5.25	± 9	± 56	± 6	63	SIP
TPI0512S	5	4.75-5.25	± 12	± 42	± 5	63	SIP
TPI0515S	5	4.75-5.25	± 15	± 33	± 4	65	SIP
TPI1205S	12	11.4-12.6	± 5	± 100	± 10	56	SIP
TPI1209S	12	11.4-12.6	± 9	± 56	± 6	62	SIP
TPI1212S	12	11.4-12.6	± 12	± 42	± 5	65	SIP
TPI1215S	12	11.4-12.6	± 15	± 33	± 4	66	SIP
TPI2405S	24	22.8-25.2	± 5	± 100	± 10	54	SIP
TPI2409S	24	22.8-25.2	± 9	± 56	± 6	62	SIP
TPI2412S	24	22.8-25.2	± 12	± 42	± 5	64	SIP
TPI2415S	24	22.8-25.2	± 15	± 33	± 4	66	SIP

Add suffix "P" for continuous short circuit protection, for example TPI0505SP.

OUTPUT SPECIFICATIONS

Parameter	Conditions	Min.	Typ.	Max.	Units
Output power		0.1		1	W
Line regulation	For Vin change of $\pm 5\%$			± 0.25	%
Load regulation	10% to 100% full load			± 1	%
Output voltage accuracy	100% full load			± 3	%
Temperature drift	100% full load			0.03	%/°C
Output ripple	20MHz Bandwidth		10	20	Mvp-p
Output Noise	20MHz Bandwidth		50	100	Mvp-p

COMMON SPECIFICATIONS

Parameter	Conditions	Min.	Typ.	Max.	Units
Storage humidity range				95	%
Operating temperature	Derating if the temperature $\geq 85^\circ\text{C}$	-40		105	°C
Storage temperature		-55		125	°C
Temp. rise at full load			20	30	°C
Lead temperature	1.5mm from case for 10 seconds			300	°C
Cooling		Free air convection			
Case material		Plastic(UL94-V0)			
Short circuit protection				1	S
MTBF		3500			K hours
Weight			5.2		g

ISOLATION CHARACTERISTICS

Parameter	Conditions	Min.	Typ.	Max.	Units
Isolation voltage	Tested for 1 minute and 1mA max	3000			VDC
Isolation resistance	Test at 1000VDC	1			GΩ

Note:

1. All specifications measured at TA=25° C, humidity<75%, nominal input voltage and rated output load unless otherwise specified.
2. See below recommended circuits for more details;
3. Operation under minimum load will not damage the converter; However, they may not meet all specification listed, and that will reduce the life of product.

TYPICAL CHARACTERISTICS

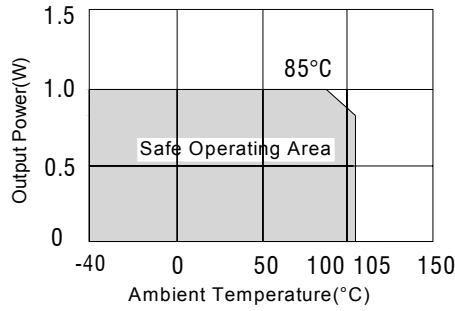

MECHANICAL DIMENSIONS

SIP Package

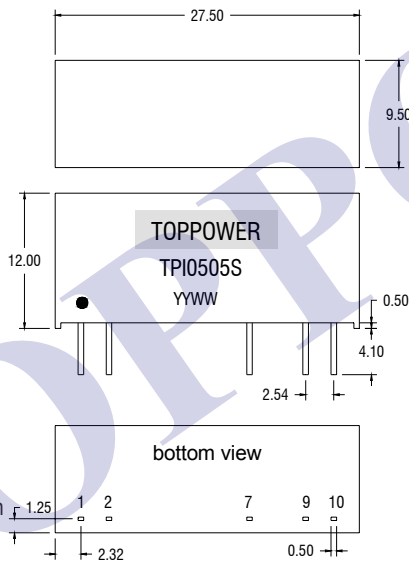

All dimensions in: mm±0.10mm
Others in ±0.25mm

PIN CONNECTIONS

10 PIN SIP	
Pin	Function
1	+Vin
2	-Vin
7	+Vout
9	-Vout
10	0V

RECOMMENDED FOOTPRINT DETAILS

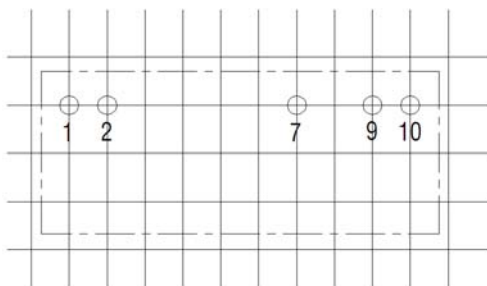

Unless otherwise stated all dimensions in mm ±0.5mm.

TUBE OUTLINE DIMENSIONS

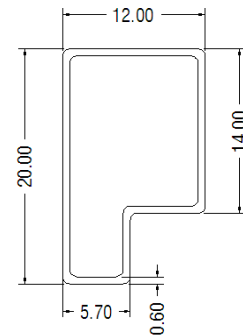

All dimensions in mm ±0.5mm.

Tube length : 520mm Tube Quantity:15PCS

APPLICATION NOTE

1.Requirement on output load

To ensure this module can operate efficiently and reliably, During operation, the minimum output load could not be less than 10% of the full load. If the actual output power is very small, please connect a resistor with proper resistance at the output end in parallel to increase the load.

2.Recommended circuit

If you want to further decrease the input/output ripple, an “LC” filtering network may be connected to the input and output ends of the DC/DC converter, see(Figure 1).

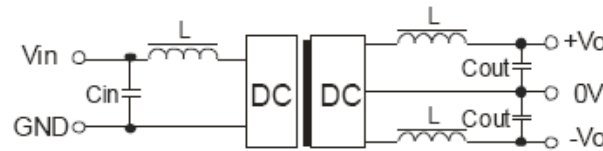

(Figure 1)

It should also be noted that the inductance and the frequency of the “LC” filtering network should be staggered with the DC/DC frequency to avoid mutual interference. However, the capacitance of the output filter capacitor must be proper. If the capacitance is too big, a startup problem might arise. For every channel of output, provided the safe and reliable operation is ensured, the greatest capacitance of its filter capacitor sees (Table 1)

EXTERNAL CAPACITOR TABLE (TABLE 1)

Vin (VDC)	Cin (μ F)	Vout (VDC)	Cout (μ F)
5	4.7	\pm 5	4.7
12	2.2	\pm 9	2.2
24	0.47	\pm 12	1
-	-	\pm 15	0.47

3.Overload Protection

Under normal operating conditions, the output circuit of these products has no protection against over-current and short-circuits. The simplest method is to connect a self-recovery fuse in series at the input end or add a circuit breaker to the circuit.

4.Input Over-voltage Protection Circuit

The simplest device for input over-voltage protection is a linear voltage regulator with overheat protection that is connected to the input end in series (Figure 2).



(Figure 2)

When the environment temperature is higher than 71°C, the product output power should be less than 60% of the rated power.

No parallel connection or plug and play.

Use dual output simultaneously , forbid opening output pin (0V) to use as single output.