

## TPIC1021A-Q1 LIN Physical Interface

### 1 Features

- LIN Physical Layer Specification Revision 2.0 Compliant and Conforms to SAEJ2602 Recommended Practice for LIN
- LIN Bus Speed up to 20-kbps LIN Specified Maximum
- Sleep Mode: Ultra-Low Current Consumption, Allows Wake-Up Events From LIN Bus, Wake-Up Input (External Switch), or Host MCU
- High-Speed Receive Capable
- ESD Protection to  $\pm 12$  kV (Human-Body Model) on LIN Pin
- LIN Pin Handles Voltage From  $-40$  V to 40 V
- Survives Transient Damage in Automotive Environment (ISO 7637)
- Extended Operation With Supply From 7 V to 27 V DC (LIN Specification 7 V to 18 V)
- Interfaces to MCU With 5-V or 3.3-V I/O Pins
- Dominant State Time-Out Protection
- Wake-Up Request on RXD Pin
- Control of External Voltage Regulator (INH Pin)
- Integrated Pullup Resistor and Series Diode for LIN Slave Applications
- Low Electromagnetic Emission (EME), High Electromagnetic Immunity (EMI)
- Bus Terminal Short-Circuit Protected for Short to Battery or Short to Ground
- Thermally Protected
- Ground Disconnection Fail-Safe at System Level
- Ground Shift Operation at System Level
- Unpowered Node Does Not Disturb the Network
- Supports ISO9141 (K-Line)-Like Functions

### 2 Applications

- In-Vehicle Networking

### 3 Description

The TPIC1021A is the Local Interconnect Network (LIN) physical interface, which integrates the serial transceiver with wake-up and protection features. The LIN bus is a single-wire bidirectional bus typically used for low-speed, in-vehicle networks using data rates between 2.4 kbps and 20 kbps. The LIN protocol output data stream on TXD is converted by the TPIC1021A into the LIN bus signal through a current-limited, wave-shaping driver as outlined by the LIN Physical Layer Specification Revision 2.0. The receiver converts the data stream from the LIN bus and outputs the data stream through RXD. The LIN bus has two states: dominant state (voltage near ground) and the recessive state (voltage near battery). In the recessive state, the LIN bus is pulled high by the TPIC1021A's internal pullup resistor (30 k $\Omega$ ) and series diode, so no external pullup components are required for slave applications. Master applications require an external pullup resistor (1 k $\Omega$ ) plus a series diode per the LIN specification.

#### Device Information<sup>(1)</sup>

PART NUMBER	PACKAGE	BODY SIZE (NOM)
TPIC1021A-Q1	SOIC (8)	4.90 mm x 3.91 mm

(1) For all available packages, see the orderable addendum at the end of the data sheet.

#### Functional Block Diagram

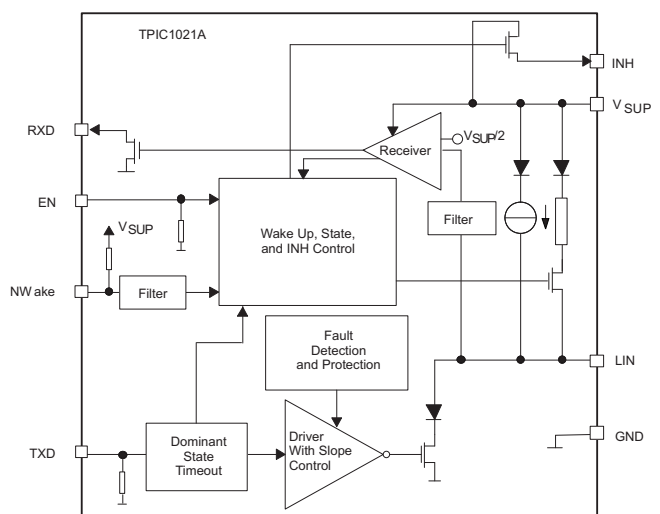

Copyright © 2016, Texas Instruments Incorporated



## Table of Contents

<b>1</b>	<b>Features</b> .....	<b>1</b>	10.2	Functional Block Diagram .....	<b>11</b>
<b>2</b>	<b>Applications</b> .....	<b>1</b>	10.3	Feature Description .....	<b>11</b>
<b>3</b>	<b>Description</b> .....	<b>1</b>	10.4	Device Functional Modes .....	<b>13</b>
<b>4</b>	<b>Revision History</b> .....	<b>2</b>	<b>11</b>	<b>Application and Implementation</b> .....	<b>17</b>
<b>5</b>	<b>Description (continued)</b> .....	<b>3</b>	11.1	Application Information .....	<b>17</b>
<b>6</b>	<b>Device Comparison Table</b> .....	<b>3</b>	11.2	Typical Application .....	<b>18</b>
<b>7</b>	<b>Pin Configuration and Functions</b> .....	<b>4</b>	<b>12</b>	<b>Power Supply Recommendations</b> .....	<b>19</b>
<b>8</b>	<b>Specifications</b> .....	<b>5</b>	<b>13</b>	<b>Layout</b> .....	<b>20</b>
8.1	Absolute Maximum Ratings .....	<b>5</b>	13.1	Layout Guidelines .....	<b>20</b>
8.2	ESD Ratings .....	<b>5</b>	13.2	Layout Example .....	<b>20</b>
8.3	Recommended Operating Conditions .....	<b>5</b>	<b>14</b>	<b>Device and Documentation Support</b> .....	<b>21</b>
8.4	Thermal Information .....	<b>6</b>	14.1	Receiving Notification of Documentation Updates .....	<b>21</b>
8.5	Electrical Characteristics .....	<b>6</b>	14.2	Community Resources .....	<b>21</b>
8.6	Typical Characteristics .....	<b>10</b>	14.3	Trademarks .....	<b>21</b>
<b>9</b>	<b>Parameter Measurement Information</b> .....	<b>10</b>	14.4	Electrostatic Discharge Caution .....	<b>21</b>
9.1	Test Circuit .....	<b>10</b>	14.5	Glossary .....	<b>21</b>
<b>10</b>	<b>Detailed Description</b> .....	<b>11</b>	<b>15</b>	<b>Mechanical, Packaging, and Orderable Information</b> .....	<b>21</b>
10.1	Overview .....	<b>11</b>			

## 4 Revision History

NOTE: Page numbers for previous revisions may differ from page numbers in the current version.

Changes from Revision A (June 2009) to Revision B		Page
•	Added <i>ESD Ratings</i> table, <i>Feature Description</i> section, <i>Device Functional Modes</i> , <i>Application and Implementation</i> section, <i>Power Supply Recommendations</i> section, <i>Layout</i> section, <i>Device and Documentation Support</i> section, and <i>Mechanical, Packaging, and Orderable Information</i> section. ....	<b>1</b>
•	Removed <i>Ordering Information</i> table, see the POA at the end of the data sheet .....	<b>1</b>

## 5 Description (continued)

In sleep mode, the TPIC1021A requires low quiescent current even though the wake-up circuits remain active, allowing for remote wakeup through the LIN bus or local wakeup through the NWake or EN pins.

The TPIC1021A has been designed for operation in the harsh automotive environment. The device can handle LIN bus voltage swings from 40 V down to ground and survive –40 V. The device also prevents back-feed current through LIN to the supply input, in case of a ground shift or supply voltage disconnection. It also features undervoltage, overtemperature, and loss-of-ground protection. In the event of a fault condition, the output is immediately switched off and remains off until the fault condition is removed.

## 6 Device Comparison Table

The TPIC1021A is pin-to-pin compatible to the TPIC1021 device. The TPIC1021A is an enhanced LIN transceiver, including enhanced immunity to RF disturbances. See [Table 1](#) for a summary of the differences between the two devices.

**Table 1. TPIC1021A vs TPIC1021 Differences**

SPECIFICATION	TPIC1021A	TPIC1021
LIN termination	Weak current pullup in sleep mode	High $\Omega$ in low-power mode
LIN receiver	Enhanced high-speed receive capable	High-speed receive capable
LIN leakage current (unpowered device): 7 V < LIN < 12 V, V <sub>SUP</sub> = GND	<5 $\mu$ A at 12 V (max)	<10 $\mu$ A at 12 V (typ)
LIN bus wakeup	Remote wakeup through recessive-to-dominant transition on LIN bus where dominant bus state is held for at least $t_{LINBUS}$ time followed by a transition back to the recessive state	Remote wakeup through recessive-to-dominant transition on LIN bus where dominant bus state is held for at least $t_{LINBUS}$ time
Low-power current	<30 $\mu$ A at 12 V (max)	<50 $\mu$ A at 14 V (max)
INH pin	Enhanced driving of bus master termination through lower R <sub>on</sub>	Driving of bus master termination

## 7 Pin Configuration and Functions

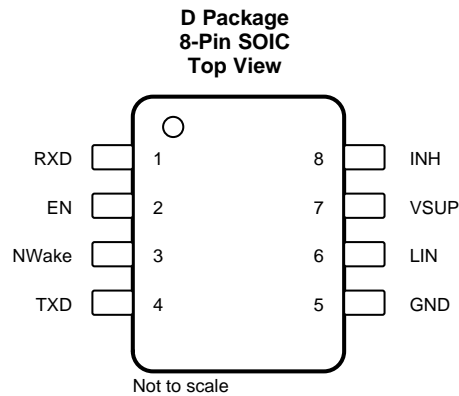

### Pin Functions

PIN		TYPE <sup>(1)</sup>	DESCRIPTION
NO.	NAME		
1	RXD	O	RXD output (open drain) interface reporting state of LIN bus voltage
2	EN	I	Enable input
3	NWake	I	High voltage input for device wakeup
4	TXD	I	TXD input interface to control state of LIN output
5	GND	G	Ground
6	LIN	I/O	LIN bus single-wire transmitter and receiver
7	V <sub>SUP</sub>	P	Device supply voltage (connected to battery in series with external reverse blocking diode)
8	INH	O	Inhibit controls external voltage regulator with inhibit input

(1) G = Ground, I = Input, O = Output, P = Power

## 8 Specifications

### 8.1 Absolute Maximum Ratings

over operating free-air temperature range (unless otherwise noted)<sup>(1)</sup>

		MIN	MAX	UNIT
$V_{SUP}$ <sup>(2)</sup>	Supply line supply voltage <sup>(3)</sup>	0	40	V
$V_{NWake}$	NWake dc and transient input voltage (through 33-k $\Omega$ serial resistor)	-0.3	40	V
$V_{INH}$	INH voltage	-0.3	$V_{SUP} + 0.3$	V
	Logic pin input voltage (RXD, TXD, EN)	-0.3	5.5	V
$V_{LIN}$	LIN dc-input voltage	-40	40	V
$I_{NWake}$	NWake current <sup>(4)</sup>		-3.6	mA
	Thermal shutdown		200	$^{\circ}$ C
	Thermal shutdown hysteresis		25	$^{\circ}$ C
$T_J$	Junction temperature	-40	150	$^{\circ}$ C
$T_{stg}$	Storage temperature	-40	165	$^{\circ}$ C

- (1) Stresses beyond those listed under *Absolute Maximum Ratings* may cause permanent damage to the device. These are stress ratings only, which do not imply functional operation of the device at these or any other conditions beyond those indicated under *Recommended Operating Conditions*. Exposure to absolute-maximum-rated conditions for extended periods may affect device reliability.
- (2) All voltage values are with respect to GND.
- (3) The device is specified for operation in the range of  $V_{SUP}$  from 7 V to 27 V. Operating the device above 27 V may significantly raise the junction temperature of the device and system level thermal design requires consideration.
- (4) If due to ground shifts,  $V_{NWake} \leq V_{GND} - 0.3$  V, thus the current into NWake must be limited through a serial resistance.

### 8.2 ESD Ratings

			VALUE	UNIT	
$V_{(ESD)}$	Electrostatic discharge	Human-body model (HBM), per ANSI/ESDA/JEDEC JS-001 <sup>(1)</sup>	All pins except 3 and 6	$\pm 4000$	V
			Pin 3	$\pm 11000$	
			Pin 6	$\pm 12000$	
		Charged-device model (CDM), per JEDEC specification JESD22-C101 <sup>(2)</sup>	$\pm 1500$		

- (1) JEDEC document JEP155 states that 500-V HBM allows safe manufacturing with a standard ESD control process.
- (2) JEDEC document JEP157 states that 250-V CDM allows safe manufacturing with a standard ESD control process.

### 8.3 Recommended Operating Conditions

over operating free-air temperature range (unless otherwise noted)

		MIN	MAX	UNIT
$T_{SUP}$	Supply voltage	7	27	V
$T_{AMB}$	Ambient temperature	-40	125	$^{\circ}$ C

## 8.4 Thermal Information

THERMAL METRIC <sup>(1)</sup>		TPIC1021	UNIT
		D (SOIC)	
		8 PINS	
R <sub>θJA</sub>	Junction-to-ambient thermal resistance	145	°C/W
R <sub>θJC(top)</sub>	Junction-to-case (top) thermal resistance	61.9	°C/W
R <sub>θJB</sub>	Junction-to-board thermal resistance	55.5	°C/W
ψ <sub>JT</sub>	Junction-to-top characterization parameter	14.3	°C/W
ψ <sub>JB</sub>	Junction-to-board characterization parameter	55	°C/W

(1) For more information about traditional and new thermal metrics, see the [Semiconductor and IC Package Thermal Metrics](#) application report.

## 8.5 Electrical Characteristics

V<sub>SUP</sub> = 7 V to 27 V, T<sub>A</sub> = –40°C to 125°C (unless otherwise noted)

PARAMETER	TEST CONDITIONS	MIN	TYP <sup>(1)</sup>	MAX	UNIT	
<b>SUPPLY</b>						
Operational supply voltage <sup>(2)</sup>	Device is operational beyond the LIN 2.0 defined nominal supply line voltage range of 7 V < V <sub>SUP</sub> < 18 V	7	14	27	V	
Nominal supply line voltage	Normal and standby modes	7	14	18		
	Sleep mode	7	12	18		
V <sub>SUP</sub> undervoltage threshold			4.5	6.2		
I <sub>CC</sub> Supply current	Normal mode, EN = High, Bus dominant (total bus load where R <sub>LIN</sub> ≥ 500 Ω and C <sub>LIN</sub> ≤ 10 nF (see <a href="#">Figure 5</a> ) <sup>(3)</sup> , INH = V <sub>SUP</sub> , NWake = V <sub>SUP</sub>		1.2	7.5	mA	
	Standby mode, EN = Low, Bus dominant (total bus load, where R <sub>LIN</sub> ≥ 500 Ω and C <sub>LIN</sub> ≤ 10 nF (see <a href="#">Figure 5</a> ) <sup>(3)</sup> , INH = V <sub>SUP</sub> , NWake = V <sub>SUP</sub>		1	2.1	mA	
	Normal mode, EN = High, Bus recessive, LIN = V <sub>SUP</sub> , INH = V <sub>SUP</sub> , NWake = V <sub>SUP</sub>			450	775	μA
	Standby mode, EN = Low, Bus recessive, LIN = V <sub>SUP</sub> , INH = V <sub>SUP</sub> , NWake = V <sub>SUP</sub>			450	775	
	Sleep mode, EN = 0, 7 V < V <sub>SUP</sub> ≤ 12 V, LIN = V <sub>SUP</sub> , NWake = V <sub>SUP</sub>			15	30	μA
	Sleep mode, EN = 0, 12 V < V <sub>SUP</sub> < 27 V, LIN = V <sub>SUP</sub> , NWake = V <sub>SUP</sub>				50	μA
<b>RXD OUTPUT PIN</b>						
V <sub>O</sub> Output voltage		–0.3		5.5	V	
I <sub>OL</sub> Low-level output current, open drain	LIN = 0 V, RXD = 0.4 V	3.5			mA	
I <sub>IKG</sub> Leakage current, high-level	LIN = V <sub>SUP</sub> , RXD = 5 V	–5	0	5	μA	
<b>TXD INPUT PIN</b>						
V <sub>IL</sub> Low-level input voltage		–0.3		0.8	V	
V <sub>IH</sub> High-level input voltage		2		5.5		
V <sub>IT</sub> Input threshold hysteresis voltage		30		500	mV	

(1) Typical values are given for V<sub>SUP</sub> = 14 V at 25°C, except for low power mode where typical values are given for V<sub>SUP</sub> = 12 V at 25°C.

(2) All voltages are defined with respect to ground; positive currents flow into the TPIC1021A device.

(3) In the dominant state, the supply current increases as the supply voltage increases due to the integrated LIN slave termination resistance. At higher voltages the majority of supply current is through the termination resistance. The minimum resistance of the LIN slave termination is 20 kΩ, so the maximum supply current attributed to the termination is:

$$I_{SUP}(\text{dom}) \text{ max termination} \neq (V_{SUP} - (V_{LIN\_Dominant} + 0.7 \text{ V})) / 20 \text{ k}\Omega$$

**Electrical Characteristics (continued)**
 $V_{SUP} = 7\text{ V to }27\text{ V}$ ,  $T_A = -40^\circ\text{C to }125^\circ\text{C}$  (unless otherwise noted)

PARAMETER	TEST CONDITIONS	MIN	TYP <sup>(1)</sup>	MAX	UNIT
Pulldown resistor		125	350	800	k $\Omega$
$I_{IL}$	Low-level input current TXD = Low	-5	0	5	$\mu\text{A}$
<b>LIN PIN (REFERENCED TO <math>V_{SUP}</math>)</b>					
$V_{OH}$	High-level output voltage LIN recessive, TXD = High, $I_O = 0\text{ mA}$ , $V_{SUP} = 14\text{ V}$	$V_{SUP} - 1$			V
$V_{OL}$	Low-level output voltage LIN dominant, TXD = Low, $I_O = 40\text{ mA}$ , $V_{SUP} = 14\text{ V}$	0	$0.2 \times V_{SUP}$		V
$R_{slave}$	Pullup resistor to $V_{SUP}$ Normal and standby modes	20	30	60	k $\Omega$
	Pullup current source to $V_{SUP}$ Sleep mode, $V_{SUP} = 14\text{ V}$ , LIN = GND	-2	-20		$\mu\text{A}$
$I_L$	Limiting current TXD = 0 V	45	160	250	mA
$I_{LKG}$	Leakage current LIN = $V_{SUP}$	-5	0	5	$\mu\text{A}$
$I_{LKG}$	Leakage current, loss of supply 7 V < LIN $\leq$ 12 V, $V_{SUP} = \text{GND}$ 12 V < LIN < 18 V, $V_{SUP} = \text{GND}$			5 10	
$V_{IL}$	Low-level input voltage LIN dominant				$0.4 \times V_{SUP}$
$V_{IH}$	High-level input voltage LIN recessive	$0.6 \times V_{SUP}$			V
$V_{IT}$	Input threshold voltage	$0.4 \times V_{SUP}$	$0.5 \times V_{SUP}$	$0.6 \times V_{SUP}$	
$V_{hys}$	Hysteresis voltage	$0.05 \times V_{SUP}$		$0.175 \times V_{SUP}$	
$V_{IL}$	Low-level input voltage for wake-up				
<b>EN PIN</b>					
$V_{IL}$	Low-level input voltage	-0.3			0.8
$V_{IH}$	High-level input voltage	2			5.5
$V_{hys}$	Hysteresis voltage	30			500
	Pulldown resistor	125	350	800	k $\Omega$
$I_{IL}$	Low-level input current EN = Low	-5	0	5	$\mu\text{A}$
<b>INH PIN</b>					
$V_o$	DC output voltage	-0.3	$V_{SUP} + 0.3$		V
$R_{on}$	On state resistance Between $V_{SUP}$ and INH, INH = 2-mA drive, Normal or standby mode	35		85	$\Omega$
$I_{LKG}$	Leakage current Low-power mode, $0 < \text{INH} < V_{SUP}$	-5	0	5	$\mu\text{A}$
<b>NWake PIN</b>					
$V_{IL}$	Low-level input voltage	-0.3	$V_{SUP} - 3.3$		V
$V_{IH}$	High-level input voltage	$V_{SUP} - 1$	$V_{SUP} + 0.3$		
	Pullup current NWake = 0 V	-45	-10	-2	$\mu\text{A}$
$I_{LKG}$	Leakage current $V_{SUP} = \text{NWake}$	-5	0	5	
<b>THERMAL SHUTDOWN</b>					
	Shutdown junction thermal temperature	190			$^\circ\text{C}$
<b>AC CHARACTERISTICS</b>					
D1	Duty cycle 1 <sup>(4)</sup>	$TH_{REC(max)} = 0.744 \times V_{SUP}$ , $TH_{DOM(max)} = 0.581 \times V_{SUP}$ , $V_{SUP} = 7\text{ V to }18\text{ V}$ , $t_{BIT} = 50\ \mu\text{s}$ (20 kbps), $D1 = t_{Bus\_rec(min)} / (2 \times t_{BIT})$ . See Figure 1		0.396	

(4) Duty cycles: LIN driver bus load conditions ( $C_{LINBUS}$ ,  $R_{LINBUS}$ ): Load1 = 1 nF, 1 k $\Omega$ ; Load2 = 10 nF, 500  $\Omega$ . Duty cycles 3 and 4 are defined for 10.4-kbps operation. The TPIC1021A also meets these lower data rate requirements, while it is capable of the higher speed 20-kbps operation as specified by Duty cycles 1 and 2. SAEJ2602 derives propagation delay equations from the LIN 2.0 duty cycle definitions, for details see the SAEJ2602 specification.

**Electrical Characteristics (continued)**
 $V_{SUP} = 7\text{ V to }27\text{ V}$ ,  $T_A = -40^\circ\text{C to }125^\circ\text{C}$  (unless otherwise noted)

PARAMETER	TEST CONDITIONS	MIN	TYP <sup>(1)</sup>	MAX	UNIT
D2 Duty cycle 2 <sup>(4)</sup>	$TH_{REC(min)} = 0.422 \times V_{SUP}$ , $TH_{DOM(min)} = 0.284 \times V_{SUP}$ , $V_{SUP} = 7.6\text{ V to }18\text{ V}$ , $t_{BIT} = 50\ \mu\text{s}$ (20 kbps), $D2 = t_{Bus\_rec(max)} / (2 \times t_{BIT})$ . See <a href="#">Figure 1</a>			0.581	
D3 Duty cycle 3 <sup>(4)</sup>	$TH_{REC(max)} = 0.778 \times V_{SUP}$ , $TH_{DOM(max)} = 0.616 \times V_{SUP}$ , $V_{SUP} = 7\text{ V to }18\text{ V}$ , $t_{BIT} = 96\ \mu\text{s}$ (10.4 kbps), $D3 = t_{Bus\_rec(min)} / (2 \times t_{BIT})$ . See <a href="#">Figure 1</a>	0.417			
D4 Duty cycle 4 <sup>(4)</sup>	$TH_{REC(min)} = 0.389 \times V_{SUP}$ , $TH_{DOM(min)} = 0.251 \times V_{SUP}$ , $V_{SUP} = 7.6\text{ V to }18\text{ V}$ , $t_{BIT} = 96\ \mu\text{s}$ (10.4 kbps), $D4 = t_{Bus\_rec(max)} / (2 \times t_{BIT})$ . See <a href="#">Figure 1</a>			0.59	
$t_{rx\_pdr}$ Receiver rising propagation delay time	$R_{RXD} = 2.4\text{ k}\Omega$ , $C_{RXD} = 20\text{ pF}$ See <a href="#">Figure 2</a> See <a href="#">Figure 5</a>			6	$\mu\text{s}$
$t_{rx\_pdf}$ Receiver falling propagation delay time	$R_{RXD} = 2.4\text{ k}\Omega$ , $C_{RXD} = 20\text{ pF}$ See <a href="#">Figure 2</a> See <a href="#">Figure 5</a>			6	
$t_{rx\_sym}$ Symmetry of receiver propagation delay time	rising edge with respect to falling edge $(t_{rx\_sym} = t_{rx\_pdf} - t_{rx\_pdr})$ $R_{RXD} = 2.4\text{ k}\Omega$ , $C_{RXD} = 20\text{ pF}$ See <a href="#">Figure 2</a> See <a href="#">Figure 5</a>	-2		2	
$t_{NWake}$ NWake filter time for local wakeup	See <a href="#">Figure 9</a>	25	50	150	
$t_{LINBUS}$ LIN wake-up filter time (dominant time for wakeup through LIN bus)	See <a href="#">Figure 8</a>	25	50	150	
$t_{DST}$ Dominant state time-out <sup>(5)</sup>		5.5		20	
$t_{go\_to\_operate}$	See <a href="#">Figure 7</a> to <a href="#">Figure 8</a>		0.5	1	$\mu\text{s}$

(5) Dominant state time-out limits the minimum data rate to 2.4 kbps.



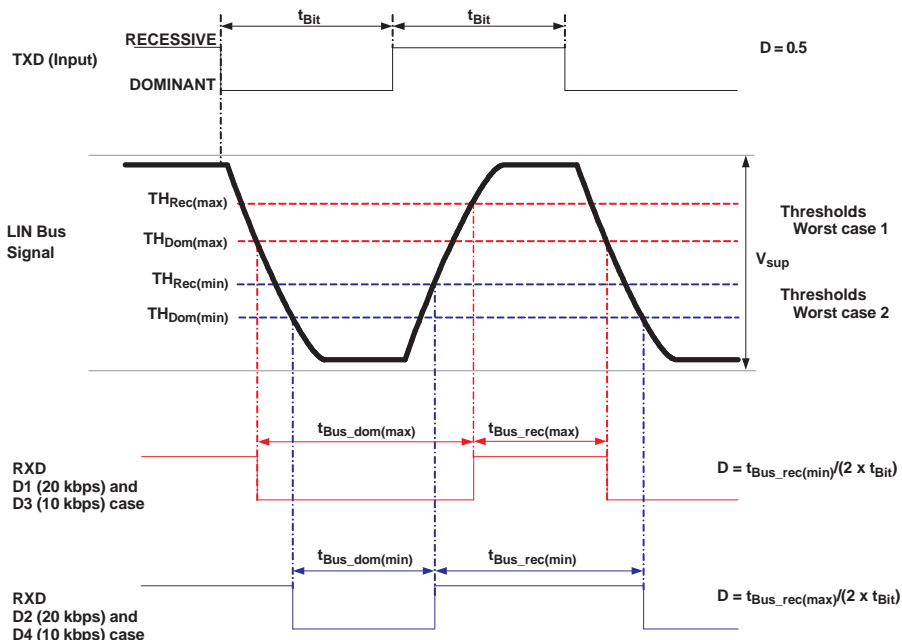

Figure 1. Definition of Bus Timing Parameters

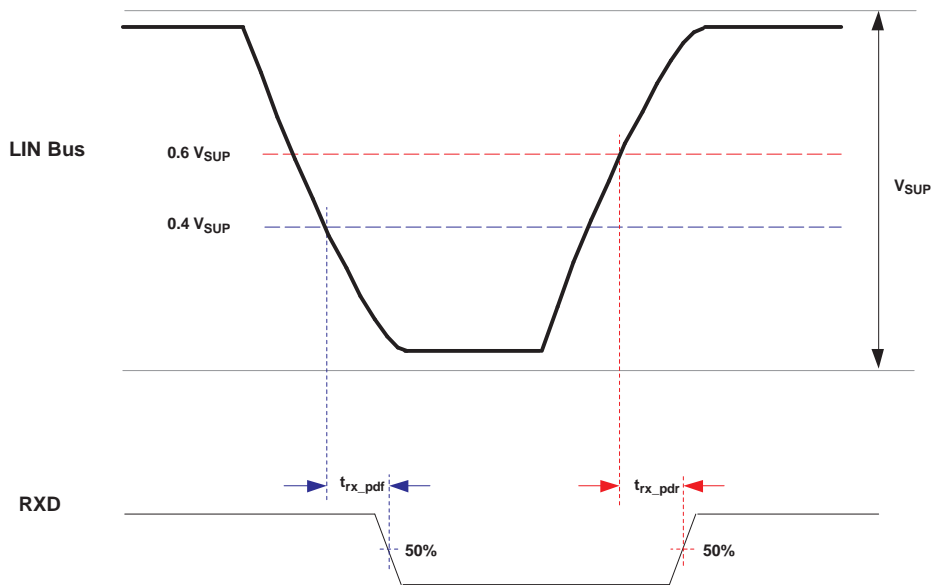

Figure 2. Propagation Delay

TPIC1021A-Q1

SLIS117B – AUGUST 2007 – REVISED JULY 2016

www.ti.com

8.6 Typical Characteristics

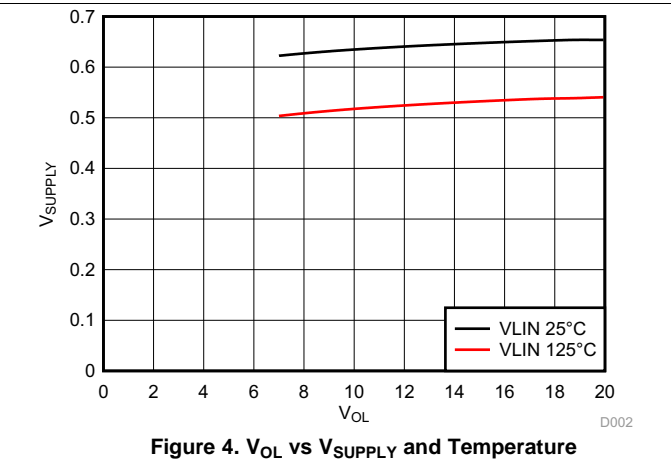
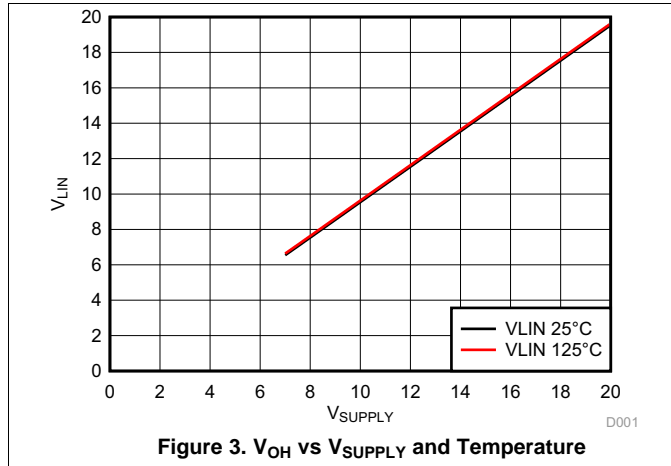

9 Parameter Measurement Information

9.1 Test Circuit

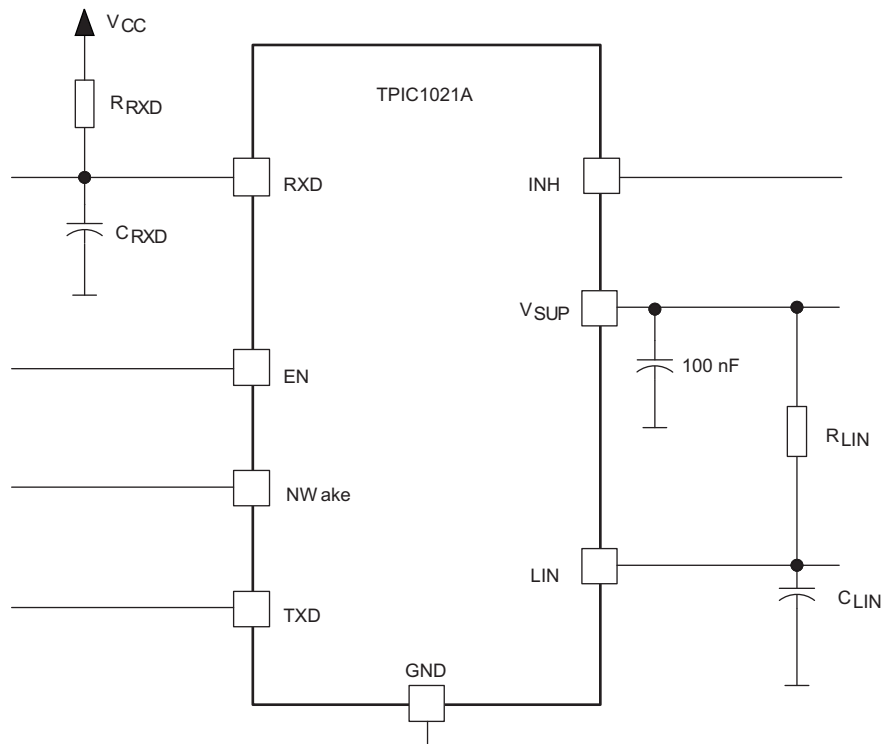

Copyright © 2016, Texas Instruments Incorporated

Figure 5. Test Circuit for AC Characteristics

## 10 Detailed Description

### 10.1 Overview

The TPIC1021A is a LIN (Local Interconnect Network) physical layer transceiver which integrates a serial transceiver with wake-up and protection features. The LIN bus is a single-wire, bidirectional bus that typically is used in low speed in vehicle networks with data rates that range from 2.4 kbps to 20 kbps.

### 10.2 Functional Block Diagram

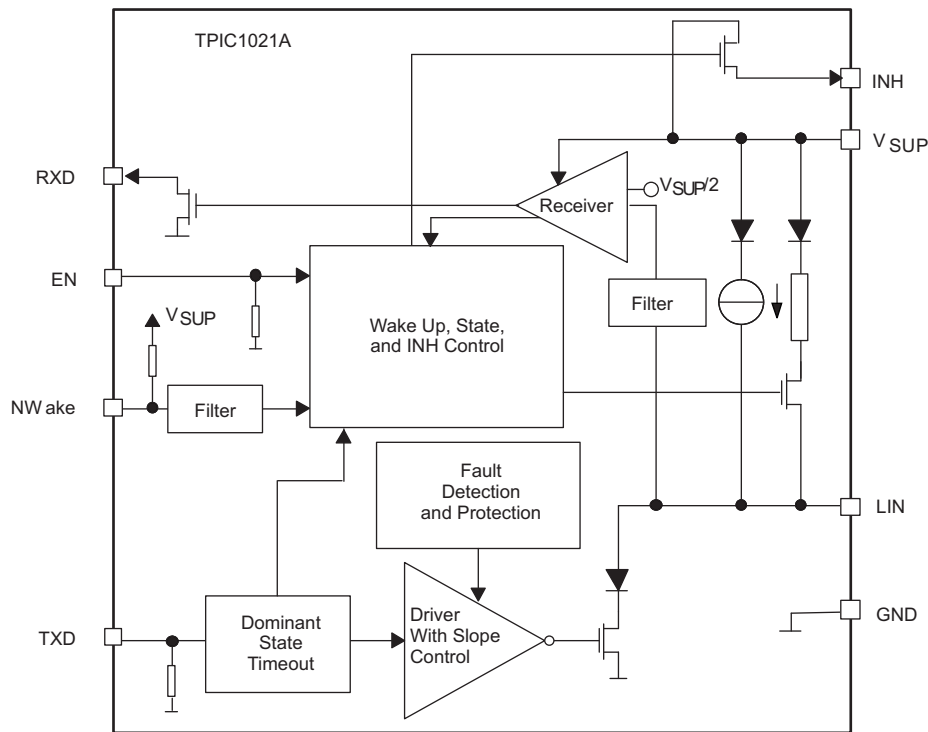

Copyright © 2016, Texas Instruments Incorporated

### 10.3 Feature Description

#### 10.3.1 Local Interconnect Network (LIN) Bus

This I/O pin is the single-wire LIN bus transmitter and receiver.

##### 10.3.1.1 Transmitter Characteristics

The driver is a low-side transistor with internal current limitation and thermal shutdown. There is an internal 30-k $\Omega$  pullup resistor with a serial diode structure to  $V_{SUP}$ , so no external pullup components are required for LIN slave mode applications. An external pullup resistor of 1 k $\Omega$ , plus a series diode to  $V_{SUP}$  must be added when the device is used for master node applications.

Voltage on LIN can go from  $-40$ -V to 40-V dc without any currents other than through the pullup resistance. There are no reverse currents from the LIN bus to supply ( $V_{SUP}$ ), even in the event of a ground shift or loss of supply ( $V_{SUP}$ ).

The LIN thresholds and ac parameters are LIN Protocol Specification Revision 2.0 compliant.

During a thermal shutdown condition, the driver is disabled.

## Feature Description (continued)

### 10.3.1.2 Receiver Characteristics

The receiver's characteristic thresholds are ratio-metric with the device supply pin. Typical thresholds are 50%, with a hysteresis between 5% and 17.5% of supply.

The receiver is capable of receiving higher data rates (>100 kbps) than supported by LIN or SAEJ2602 specifications. This allows the TPIC1021A to be used for high-speed downloads at end-of-line production or other applications. The actual data rates achievable depend on system time constants (bus capacitance and pullup resistance) and driver characteristics used in the system.

### 10.3.2 Transmit Input (TXD)

TXD is the interface to the MCU's LIN protocol controller or SCI/UART used to control the state of the LIN output. When TXD is low, the LIN output is dominant (near ground). When TXD is high, the LIN output is recessive (near battery). The TXD input structure is compatible with microcontrollers with 3.3-V and 5-V I/O. TXD has an internal pulldown resistor.

#### 10.3.2.1 TXD Dominant State Time-Out

If TXD is inadvertently driven permanently low by a hardware or software application failure, the LIN bus is protected by TPIC1021A's dominant state time-out timer. This timer is triggered by a falling edge on TXD. If the low signal remains on TXD for longer than  $t_{DST}$ , the transmitter is disabled, thus allowing the LIN bus to return to the recessive state and communication to resume on the bus. The timer is reset by a rising edge on TXD.

### 10.3.3 Receive Output (RXD)

RXD is the interface to the MCU's LIN protocol controller or SCI/UART, which reports the state of the LIN bus voltage. LIN recessive (near battery) is represented by a high level on RXD and LIN dominant (near ground) is represented by a low level on RXD. The RXD output structure is an open-drain output stage. This allows the TPIC1021A to be used with 3.3-V and 5-V I/O microcontrollers. If the microcontroller's RXD pin does not have an integrated pullup, an external pullup resistor to the microcontroller I/O supply voltage is required.

#### 10.3.3.1 RXD Wake-up Request

When the TPIC1021A has been in low-power mode and encounters a wake-up event from the LIN bus or NWake pin, RXD goes low, while the device enters and remains in standby mode (until EN is reasserted high and the device enters normal mode).

### 10.3.4 Supply Voltage ( $V_{SUP}$ )

$V_{SUP}$  is the TPIC1021A device power supply pin.  $V_{SUP}$  is connected to the battery through an external reverse battery blocking diode. The characterized operating voltage range for the TPIC1021A is from 7 V to 27 V.  $V_{SUP}$  is protected for harsh automotive conditions up to 40 V.

The device contains a reset circuit to avoid false bus messages during undervoltage conditions when  $V_{SUP}$  is less than  $V_{SUP\_UNDER}$ .

### 10.3.5 Ground (GND)

GND is the TPIC1021A device ground connection. The TPIC1021A can operate with a ground shift as long as the ground shift does not reduce  $V_{SUP}$  below the minimum operating voltage. If there is a loss of ground at the ECU level, the TPIC1021A does not have a significant current consumption on LIN bus.

### 10.3.6 Enable Input (EN)

EN controls the operation mode of the TPIC1021A (normal or sleep mode). When EN is high, the TPIC1021A is in normal mode allowing a transmission path from TXD to LIN and from LIN to RXD. When EN is low the device is put into sleep mode and there are no transmission paths available. The device can enter normal mode only after being woken up. EN has an internal pulldown resistor to ensure the device remains in low-power mode even if EN floats.

## Feature Description (continued)

### 10.3.7 NWake Input (NWake)

NWake is a high-voltage input used to wake up the TPIC1021A from low-power mode. NWake is usually connected to an external switch in the application. A low on NWake that is asserted longer than the filter time ( $t_{NWAKE}$ ) results in a local wakeup. NWake provides an internal pullup source to  $V_{SUP}$ .

### 10.3.8 Inhibit Output (INH)

INH is used to control an external voltage regulator that has an inhibit input. When the TPIC1021A is in normal operating mode, the inhibit high-side switch is enabled and the external voltage regulator is activated. When TPIC1021A is in low-power mode, the inhibit switch is turned off, which disables the voltage regulator. A wake-up event on for the TPIC1021A returns INH to  $V_{SUP}$  level. INH can also drive an external transistor connected to an MCU interrupt input.

## 10.4 Device Functional Modes

### 10.4.1 Operating States

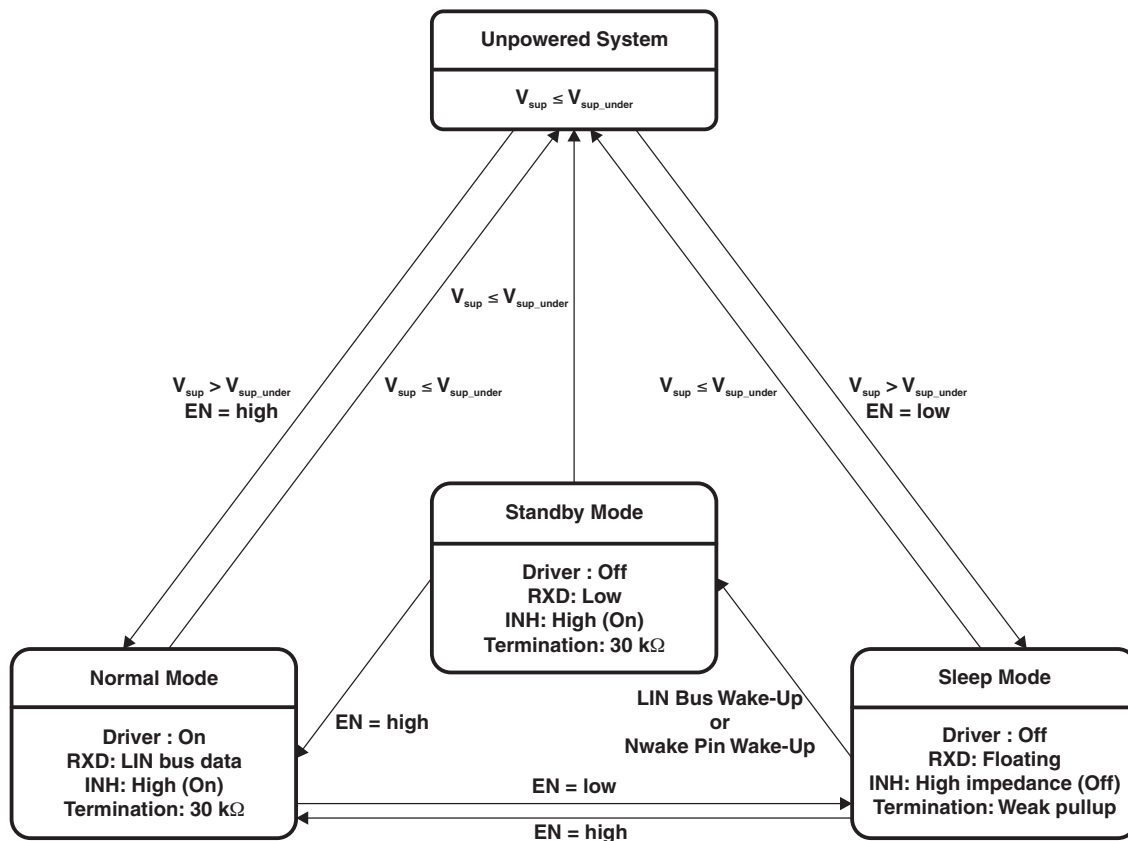

Figure 6. Operating States Diagram

Table 2. Operating Modes

MODE	EN	RXD	LIN BUS TERMINATION	INH	TRANSMITTER	COMMENTS
Sleep	Low	Floating	Weak current pullup	High impedance	Off	
Standby	Low	Low	30 kΩ (typical)	High	Off	Wake-up event detected, waiting on MCU to set EN
Normal	High	LIN bus data	30 kΩ (typical)	High	On	LIN transmission up to 20 kbps

#### 10.4.1.1 Normal Mode

This is the normal operational mode, in which the receiver and driver are active, and LIN transmission up to the LIN specified maximum of 20 kbps is supported. The receiver detects the data stream on the LIN bus and outputs it on RXD for the LIN controller, where recessive on the LIN bus is a digital high, and dominant on the LIN bus is digital low. The driver transmits input data on TXD to the LIN bus. Normal mode is entered as EN transitions high while the TPIC1021A is in sleep or standby mode.

#### 10.4.1.2 Sleep Mode

Sleep mode is the power saving mode for the TPIC1021A and the default state after power up (assuming EN is low during power up). Even with the extremely low current consumption in this mode, the TPIC1021A can still wake up from LIN bus through a wake-up signal, a low on NWake, or if EN is set high. The LIN bus and NWake are filtered to prevent false wake-up events. The wake-up events must be active for their respective time periods ( $t_{\text{LINBUS}}$ ,  $t_{\text{NWake}}$ ).

The sleep mode is entered by setting EN low.

While the device is in sleep mode, the following conditions exist:

- The LIN bus driver is disabled and the internal LIN bus termination is switched off (to minimize power loss if LIN is short circuited to ground). However, the weak current pullup is active to prevent false wake-up events in case an external connection to the LIN bus is lost.
- The normal receiver is disabled.
- INH is high impedance.
- EN input, NWake input, and the LIN wake-up receiver are active.

#### 10.4.1.2.1 Wake-Up Events

There are three ways to wake up the TPIC1021A from sleep mode:

- Remote wakeup through recessive (high) to dominant (low) state transition on LIN bus. The dominant state must be held for  $t_{\text{LINBUS}}$  filter time and then the bus must return to the recessive state (to eliminate false wakeups from disturbances on the LIN bus or if the bus is shorted to ground).
- Local wakeup through a low on NWake, which is asserted low longer than the filter time  $t_{\text{NWake}}$  (to eliminate false wakeups from disturbances on NWake)
- Local wakeup through EN being set high

#### 10.4.1.3 Standby Mode

This mode is entered whenever a wake-up event occurs through LIN bus or NWake while the TPIC1021A is in sleep mode. The LIN bus slave termination circuit and INH are turned on when standby mode is entered. The application system powers up once INH is turned on, assuming the system is using a voltage regulator connected through INH. Standby mode is signaled through a low level on RXD.

When EN is set high while the TPIC1021A is in standby mode the device returns to normal mode and the normal transmission paths from TXD to LIN bus and LIN bus to RXD are enabled.

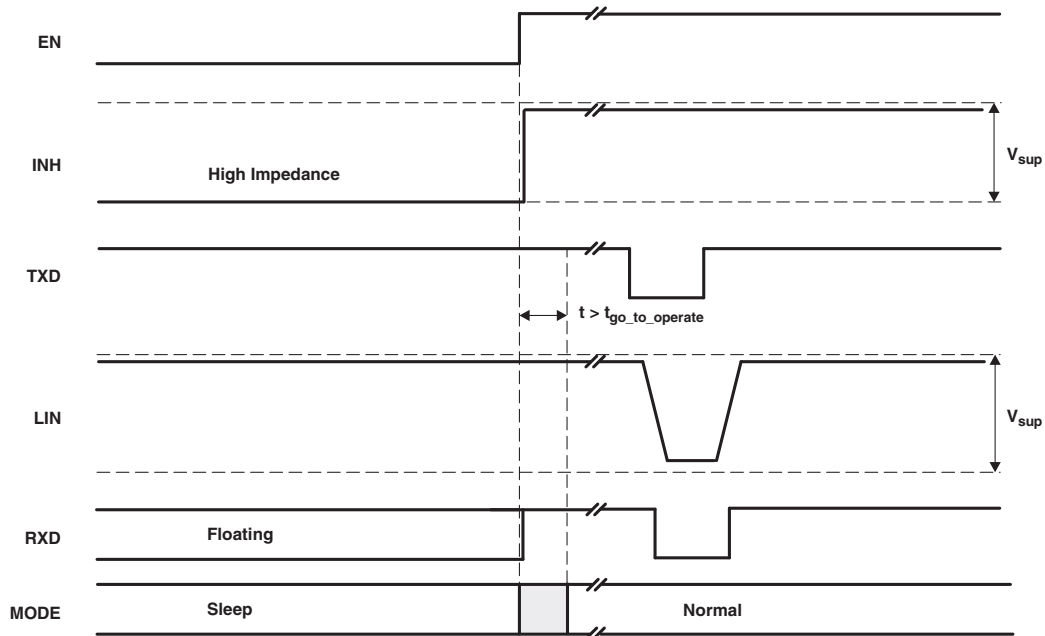

Figure 7. Wakeup Through EN

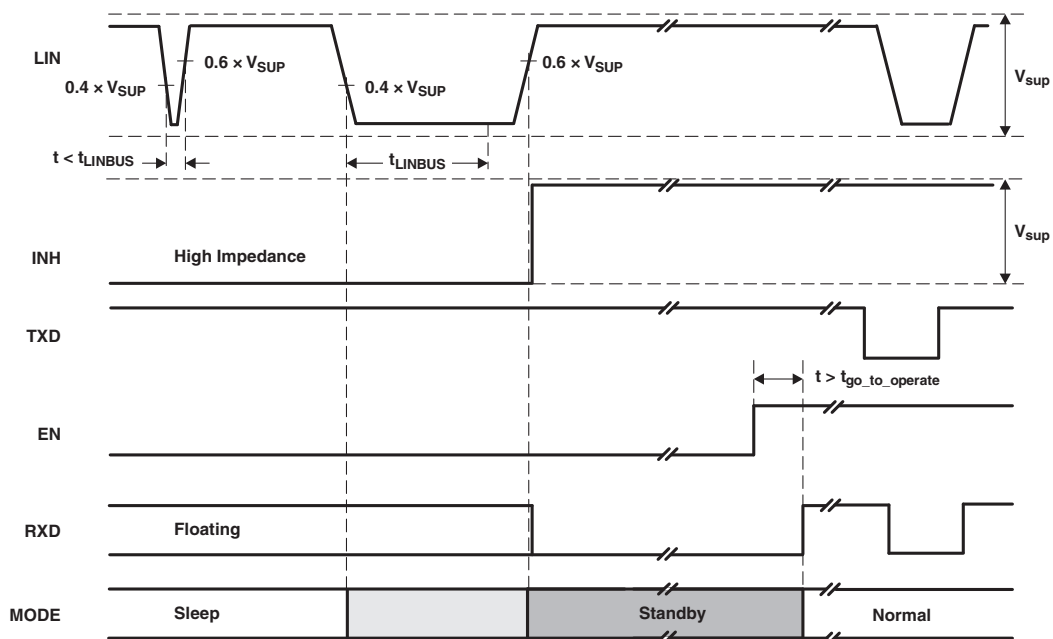
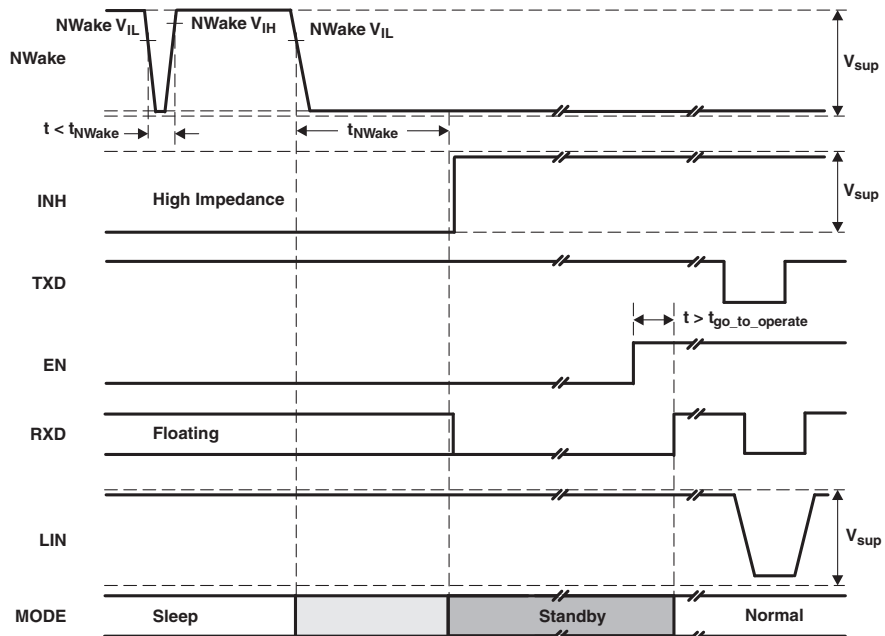

Figure 8. Wakeup Through LIN



**Figure 9. Wakeup Through Nwake**



## 11 Application and Implementation

---

### NOTE

Information in the following applications sections is not part of the TI component specification, and TI does not warrant its accuracy or completeness. TI's customers are responsible for determining suitability of components for their purposes. Customers should validate and test their design implementation to confirm system functionality.

---

### 11.1 Application Information

The TPIC1021A can be used as both a slave device and a master device in a LIN network. It comes with the ability to support both remote wake-up requests and local wake-up requests.

## 11.2 Typical Application

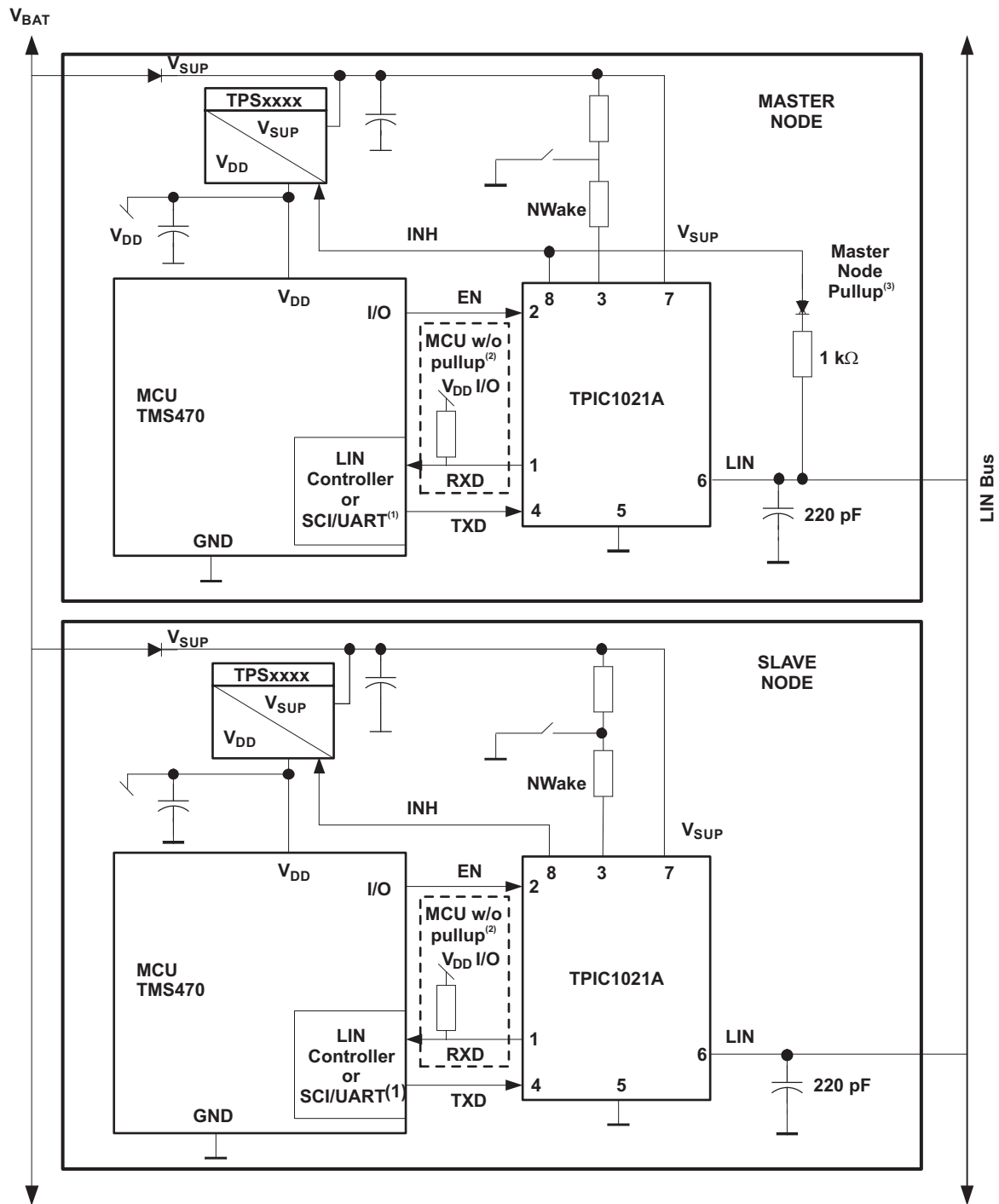

Copyright © 2016, Texas Instruments Incorporated

- (1) RXD on MCU or LIN slave has internal pullup, no external pullup resistor is required.
- (2) RXD on MCU or LIN slave without internal pullup, requires external pullup resistor.
- (3) Master node applications require an external 1-kΩ pullup resistor and serial diode.

**Figure 10. Typical Application Schematic**

## Typical Application (continued)

### 11.2.1 Design Requirements

For this application example, use these requirements:

1. RXD on MCU or LIN Slave has internal pullup, no external pullup resistor is required.
2. RXD on MCU or LIN Slave without internal pullup, requires external pullup resistor.
3. Master Node applications require an external 1-k $\Omega$  pullup resistor and serial diode.

### 11.2.2 Detailed Design Procedure

The RXD output structure is an open-drain output stage. This allows the TPIC1021A to be used with 3.3-V and 5-V I/O microcontrollers. If the RXD pin of the microcontroller does not have an integrated pullup, an external pullup resistor to the microcontroller I/O supply voltage is required.

The V<sub>SUP</sub> pin of the device must be decoupled with a 100-nF capacitor as close to the supply pin of the device as possible.

The NWAKE pin is a high voltage wake-up input to the device. If this pin is not being used it must be tied to V<sub>SUP</sub>.

### 11.2.3 Application Curves

Figure 11 and Figure 12 show the propagation delay from the TXD pin to the LIN pin for both the recessive to dominant and dominant to recessive states under lightly loaded conditions.

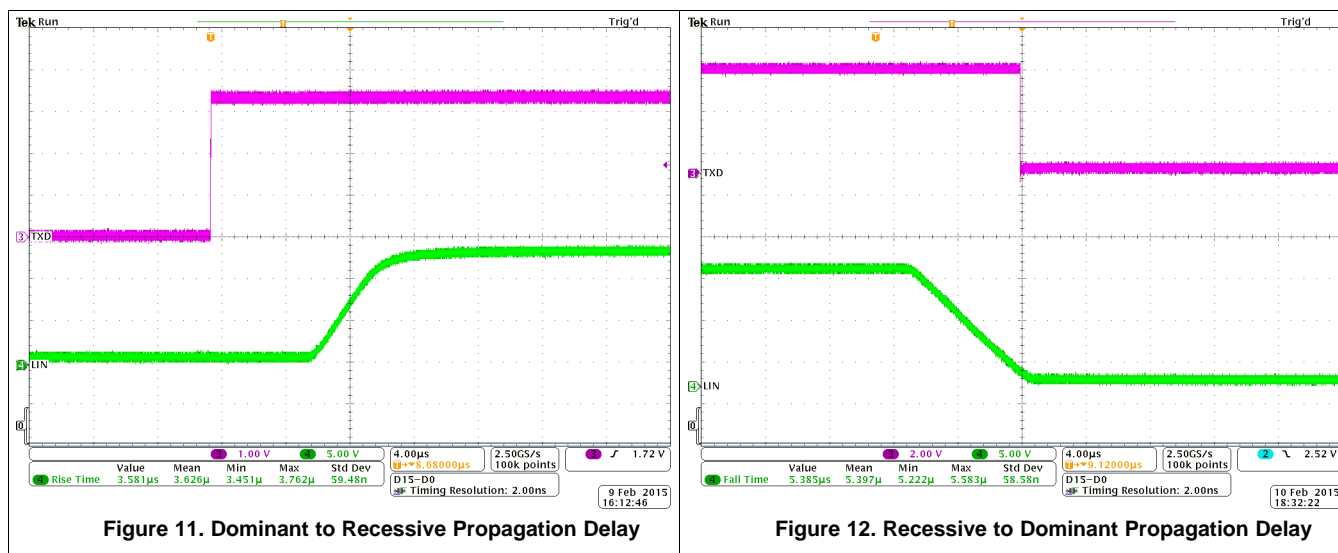

## 12 Power Supply Recommendations

The TPIC1021A was designed to operate directly off car battery, or any other DC supply ranging from 7 V to 27 V. A 100-nF decoupling capacitor must be placed as close to the V<sub>SUP</sub> pin of the device as possible.

## 13 Layout

### 13.1 Layout Guidelines

- Pin 1 is the RXD output of the TPIC1021A. It is an open-drain output and requires an external pullup resistor in the range of 1 to 10 k $\Omega$  to function properly. If the micro-processor paired with the transceiver does not have an integrated pullup, an external resistor must be placed between RXD and the regulated voltage supply for the micro-processor.
- Pin 2 is the EN input pin for the device that is used to place the device in low power sleep mode. If this feature is not used on the device, the pin must be pulled high to the regulated voltage supply of the micro-processor through a series 1-k $\Omega$  to 10-k $\Omega$  series resistor. Additionally, a series resistor may be placed on the pin to limit the current on the digital lines in the case of an overvoltage fault.
- Pin 3 is a high-voltage local wake-up input pin. The device is typically externally controlled by a normally open switch tied between NWAKE and ground. When the momentary switch is pressed the NWAKE pin is pulled to ground signaling a local wake-up event. A series resistor between VBATT and the switch, and NWAKE and the switch must be placed to limit current. If the NWAKE local wake-up feature is not used, the pin can be tied to V<sub>SUP</sub> through a 1-k $\Omega$  to 10-k $\Omega$  pullup resistor.
- Pin 4 is the transmit input signal to the device. A series resistor can be placed to limit the input current to the device in the case of an overvoltage on this pin. Also a capacitor to ground can be placed close to the input pin of the device to filter noise.
- Pin 5 is the ground connection of the device. This pin must be tied to a ground plane through a short trace with the use of two vias to limit total return inductance.
- Pin 6 is the LIN bus connection of the device. For slave applications a 220-pF bus capacitor is implemented. For master applications an additional series resistor and blocking diode must be placed between the LIN pin and the V<sub>SUP</sub> pin.
- Pin 7 is the supply pin for the device. A 100-nF decoupling capacitor must be placed as close to the device as possible.
- Pin 8 is a high-voltage output pin that may be used to control the local power supplies. If this feature is not used the pin may be left floating.

#### NOTE

All ground and power connections must be made as short as possible and use at least two vias to minimize the total loop inductance.

### 13.2 Layout Example

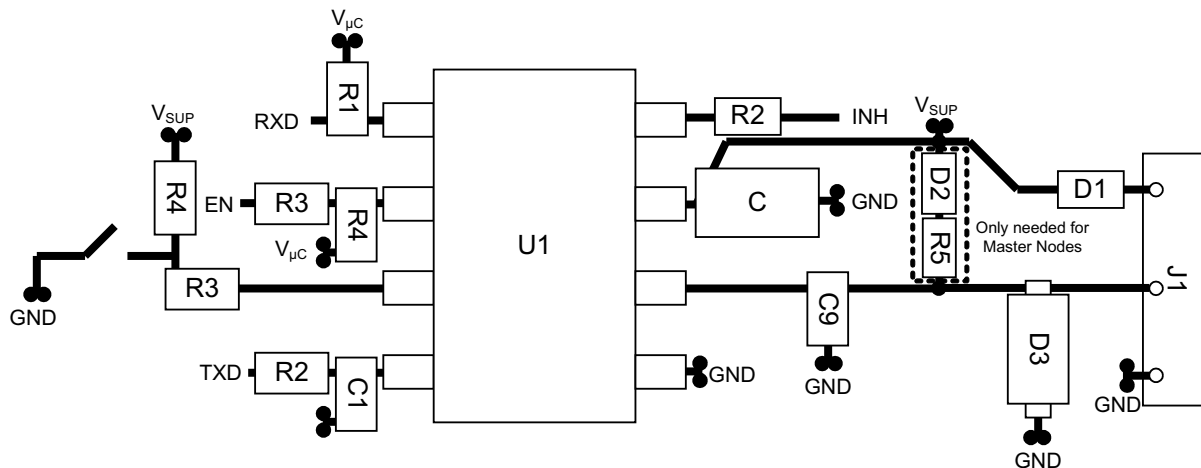

**Figure 13. TPIC1021A-Q1 Layout**

## 14 Device and Documentation Support

### 14.1 Receiving Notification of Documentation Updates

To receive notification of documentation updates, navigate to the device product folder on ti.com. In the upper right corner, click on *Alert me* to register and receive a weekly digest of any product information that has changed. For change details, review the revision history included in any revised document.

### 14.2 Community Resources

The following links connect to TI community resources. Linked contents are provided "AS IS" by the respective contributors. They do not constitute TI specifications and do not necessarily reflect TI's views; see TI's [Terms of Use](#).

**TI E2E™ Online Community** *TI's Engineer-to-Engineer (E2E) Community*. Created to foster collaboration among engineers. At e2e.ti.com, you can ask questions, share knowledge, explore ideas and help solve problems with fellow engineers.

**Design Support** *TI's Design Support* Quickly find helpful E2E forums along with design support tools and contact information for technical support.

### 14.3 Trademarks

E2E is a trademark of Texas Instruments.  
All other trademarks are the property of their respective owners.

### 14.4 Electrostatic Discharge Caution



These devices have limited built-in ESD protection. The leads should be shorted together or the device placed in conductive foam during storage or handling to prevent electrostatic damage to the MOS gates.

### 14.5 Glossary

[SLYZ022](#) — *TI Glossary*.

This glossary lists and explains terms, acronyms, and definitions.

## 15 Mechanical, Packaging, and Orderable Information

The following pages include mechanical, packaging, and orderable information. This information is the most current data available for the designated devices. This data is subject to change without notice and revision of this document. For browser-based versions of this data sheet, refer to the left-hand navigation.

**PACKAGING INFORMATION**

Orderable Device	Status (1)	Package Type	Package Drawing	Pins	Package Qty	Eco Plan (2)	Lead/Ball Finish (6)	MSL Peak Temp (3)	Op Temp (°C)	Device Marking (4/5)	Samples
TPIC1021AQDRQ1	NRND	SOIC	D	8	2500	Green (RoHS & no Sb/Br)	CU NIPDAU	Level-1-260C-UNLIM	-40 to 125	T1021A	

(1) The marketing status values are defined as follows:

**ACTIVE:** Product device recommended for new designs.

**LIFEBUY:** TI has announced that the device will be discontinued, and a lifetime-buy period is in effect.

**NRND:** Not recommended for new designs. Device is in production to support existing customers, but TI does not recommend using this part in a new design.

**PREVIEW:** Device has been announced but is not in production. Samples may or may not be available.

**OBSOLETE:** TI has discontinued the production of the device.

(2) **RoHS:** TI defines "RoHS" to mean semiconductor products that are compliant with the current EU RoHS requirements for all 10 RoHS substances, including the requirement that RoHS substance do not exceed 0.1% by weight in homogeneous materials. Where designed to be soldered at high temperatures, "RoHS" products are suitable for use in specified lead-free processes. TI may reference these types of products as "Pb-Free".

**RoHS Exempt:** TI defines "RoHS Exempt" to mean products that contain lead but are compliant with EU RoHS pursuant to a specific EU RoHS exemption.

**Green:** TI defines "Green" to mean the content of Chlorine (Cl) and Bromine (Br) based flame retardants meet JS709B low halogen requirements of <=1000ppm threshold. Antimony trioxide based flame retardants must also meet the <=1000ppm threshold requirement.

(3) MSL, Peak Temp. - The Moisture Sensitivity Level rating according to the JEDEC industry standard classifications, and peak solder temperature.

(4) There may be additional marking, which relates to the logo, the lot trace code information, or the environmental category on the device.

(5) Multiple Device Markings will be inside parentheses. Only one Device Marking contained in parentheses and separated by a "~" will appear on a device. If a line is indented then it is a continuation of the previous line and the two combined represent the entire Device Marking for that device.

(6) Lead/Ball Finish - Orderable Devices may have multiple material finish options. Finish options are separated by a vertical ruled line. Lead/Ball Finish values may wrap to two lines if the finish value exceeds the maximum column width.

**Important Information and Disclaimer:**The information provided on this page represents TI's knowledge and belief as of the date that it is provided. TI bases its knowledge and belief on information provided by third parties, and makes no representation or warranty as to the accuracy of such information. Efforts are underway to better integrate information from third parties. TI has taken and continues to take reasonable steps to provide representative and accurate information but may not have conducted destructive testing or chemical analysis on incoming materials and chemicals. TI and TI suppliers consider certain information to be proprietary, and thus CAS numbers and other limited information may not be available for release.

In no event shall TI's liability arising out of such information exceed the total purchase price of the TI part(s) at issue in this document sold by TI to Customer on an annual basis.

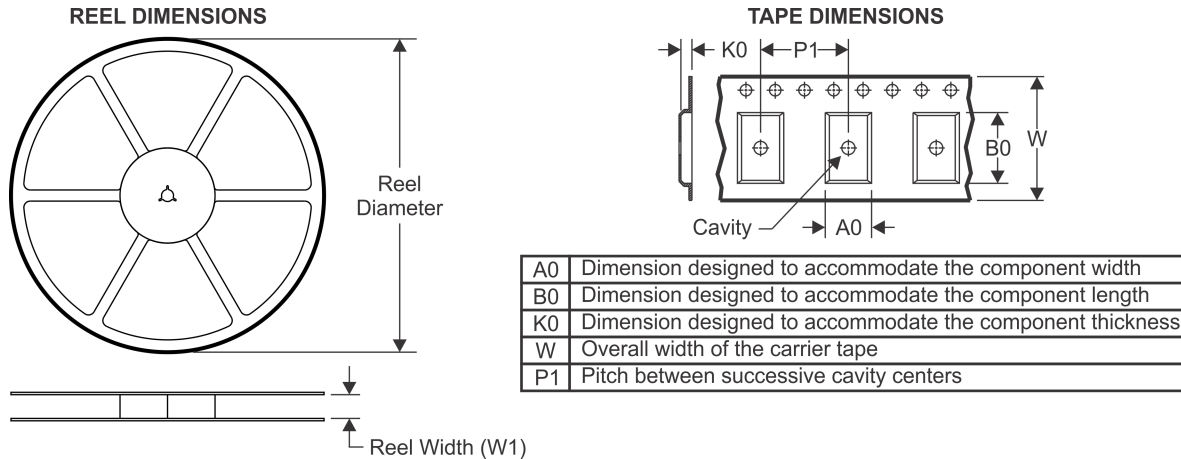
**TAPE AND REEL INFORMATION**

**QUADRANT ASSIGNMENTS FOR PIN 1 ORIENTATION IN TAPE**

\*All dimensions are nominal

Device	Package Type	Package Drawing	Pins	SPQ	Reel Diameter (mm)	Reel Width W1 (mm)	A0 (mm)	B0 (mm)	K0 (mm)	P1 (mm)	W (mm)	Pin1 Quadrant
TPIC1021AQDRQ1	SOIC	D	8	2500	330.0	12.4	6.4	5.2	2.1	8.0	12.0	Q1

TAPE AND REEL BOX DIMENSIONS



\*All dimensions are nominal

Device	Package Type	Package Drawing	Pins	SPQ	Length (mm)	Width (mm)	Height (mm)
TPIC1021AQDRQ1	SOIC	D	8	2500	367.0	367.0	35.0





D0008A

# PACKAGE OUTLINE

SOIC - 1.75 mm max height

SMALL OUTLINE INTEGRATED CIRCUIT



4214825/C 02/2019

NOTES:

- Linear dimensions are in inches [millimeters]. Dimensions in parenthesis are for reference only. Controlling dimensions are in inches. Dimensioning and tolerancing per ASME Y14.5M.
- This drawing is subject to change without notice.
- This dimension does not include mold flash, protrusions, or gate burrs. Mold flash, protrusions, or gate burrs shall not exceed .006 [0.15] per side.
- This dimension does not include interlead flash.
- Reference JEDEC registration MS-012, variation AA.

# EXAMPLE BOARD LAYOUT

D0008A

SOIC - 1.75 mm max height

SMALL OUTLINE INTEGRATED CIRCUIT



LAND PATTERN EXAMPLE  
 EXPOSED METAL SHOWN  
 SCALE:8X



SOLDER MASK DETAILS

4214825/C 02/2019

NOTES: (continued)

- 6. Publication IPC-7351 may have alternate designs.
- 7. Solder mask tolerances between and around signal pads can vary based on board fabrication site.

# EXAMPLE STENCIL DESIGN

D0008A

SOIC - 1.75 mm max height

SMALL OUTLINE INTEGRATED CIRCUIT



SOLDER PASTE EXAMPLE  
BASED ON .005 INCH [0.125 MM] THICK STENCIL  
SCALE:8X

4214825/C 02/2019

NOTES: (continued)

8. Laser cutting apertures with trapezoidal walls and rounded corners may offer better paste release. IPC-7525 may have alternate design recommendations.
9. Board assembly site may have different recommendations for stencil design.

## IMPORTANT NOTICE AND DISCLAIMER

TI PROVIDES TECHNICAL AND RELIABILITY DATA (INCLUDING DATASHEETS), DESIGN RESOURCES (INCLUDING REFERENCE DESIGNS), APPLICATION OR OTHER DESIGN ADVICE, WEB TOOLS, SAFETY INFORMATION, AND OTHER RESOURCES "AS IS" AND WITH ALL FAULTS, AND DISCLAIMS ALL WARRANTIES, EXPRESS AND IMPLIED, INCLUDING WITHOUT LIMITATION ANY IMPLIED WARRANTIES OF MERCHANTABILITY, FITNESS FOR A PARTICULAR PURPOSE OR NON-INFRINGEMENT OF THIRD PARTY INTELLECTUAL PROPERTY RIGHTS.

These resources are intended for skilled developers designing with TI products. You are solely responsible for (1) selecting the appropriate TI products for your application, (2) designing, validating and testing your application, and (3) ensuring your application meets applicable standards, and any other safety, security, or other requirements. These resources are subject to change without notice. TI grants you permission to use these resources only for development of an application that uses the TI products described in the resource. Other reproduction and display of these resources is prohibited. No license is granted to any other TI intellectual property right or to any third party intellectual property right. TI disclaims responsibility for, and you will fully indemnify TI and its representatives against, any claims, damages, costs, losses, and liabilities arising out of your use of these resources.

TI's products are provided subject to TI's Terms of Sale ([www.ti.com/legal/termsofsale.html](http://www.ti.com/legal/termsofsale.html)) or other applicable terms available either on [ti.com](http://ti.com) or provided in conjunction with such TI products. TI's provision of these resources does not expand or otherwise alter TI's applicable warranties or warranty disclaimers for TI products.

Mailing Address: Texas Instruments, Post Office Box 655303, Dallas, Texas 75265  
Copyright © 2019, Texas Instruments Incorporated