

# TPIC1501A QUAD AND HEX POWER DMOS ARRAY

SLIS046A – MAY 1995 – REVISED JUNE 1996

- **Low  $r_{DS(on)}$ :**  
0.1  $\Omega$  Typ (Full H-Bridge)  
0.4  $\Omega$  Typ (Triple Half H-Bridge)
- **Pulsed Current:**  
12 A Per Channel (Full H-Bridge)  
6 A Per Channel (Triple Half H-Bridge)
- **Matched Sense Transistor for Class A-B Linear Operation**
- **Fast Commutation Speed**

## description

The TPIC1501A is a monolithic power array that consists of ten electrically isolated N-channel enhancement-mode power DMOS transistors, four of which are configured as a full H-bridge and six as a triple half H-bridge. The lower stage of the full H-bridge features an integrated sense FET to allow biasing of the bridge in class A-B operation.

The TPIC1501A is offered in a 24-pin wide-body surface-mount (DW) package and is characterized for operation over the case temperature range of  $-40^{\circ}\text{C}$  to  $125^{\circ}\text{C}$ .

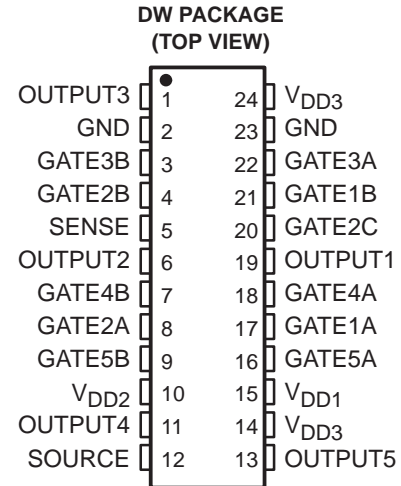

## schematic

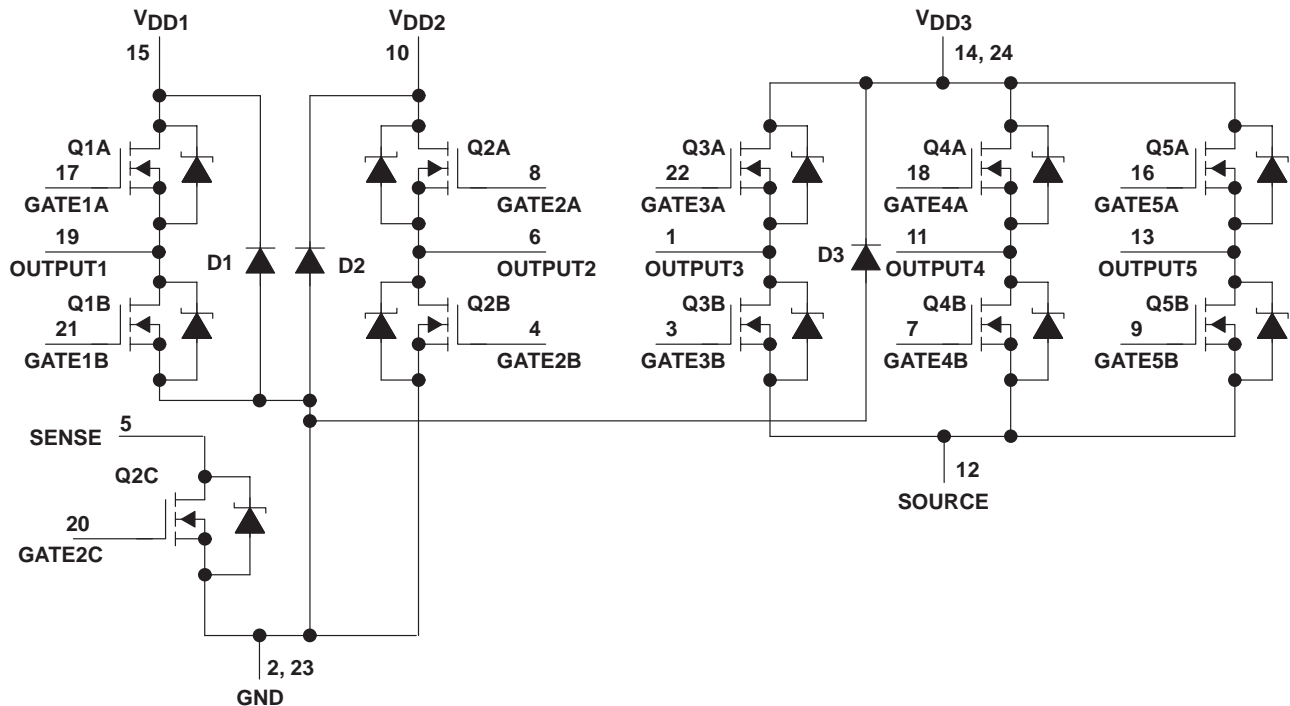

- NOTES: A. Pins 2 and 23 must be externally connected.  
B. Pins 14 and 24 must be externally connected.  
C. No output may be taken greater than 0.5 V below GND.



Please be aware that an important notice concerning availability, standard warranty, and use in critical applications of Texas Instruments semiconductor products and disclaimers thereto appears at the end of this data sheet.

PRODUCTION DATA information is current as of publication date. Products conform to specifications per the terms of Texas Instruments standard warranty. Production processing does not necessarily include testing of all parameters.

**TEXAS  
INSTRUMENTS**

POST OFFICE BOX 655303 • DALLAS, TEXAS 75265

Copyright © 1996, Texas Instruments Incorporated

# TPIC1501A

## QUAD AND HEX POWER DMOS ARRAY

SLIS046A – MAY 1995 – REVISED JUNE 1996

### absolute maximum ratings, $T_C = 25^\circ\text{C}$ (unless otherwise noted)<sup>†</sup>

Supply-to-GND voltage	20 V
Source-to-GND voltage (Q3A, Q4A, Q5A)	20 V
Output-to-GND voltage	20 V
Sense-to-GND voltage	20 V
Gate-to-source voltage range, $V_{GS}$ (Q1A, Q1B, Q2A, Q2B, Q3A, Q3B, Q4A, Q4B, Q5A, Q5B)	$\pm 20$ V
Gate-to-source voltage range, $V_{GS}$ (Q2C)	-0.7 V to 6 V
Continuous drain current, each output (Q1A, Q1B, Q2A, Q2B)	3 A
Continuous drain current, each output (Q3A, Q3B, Q4A, Q4B, Q5A, Q5B)	1.5 A
Continuous drain current (Q2C)	15 mA
Continuous source-to-drain diode current (Q1A, Q1B, Q2A, Q2B)	3 A
Continuous source-to-drain diode current (Q3A, Q3B, Q4A, Q4B, Q5A, Q5B)	1.5 A
Continuous source-to-drain diode current (Q2C)	15 mA
Pulsed drain current, each output, $I_{max}$ (Q1A, Q1B, Q2A, Q2B) (see Note 1 and Figure 24)	12 A
Pulsed drain current, each output, $I_{max}$ (Q3A, Q3B, Q4A, Q4B, Q5A, Q5B) (see Note 1 and Figure 25)	6 A
Pulsed drain current, $I_{max}$ (Q2C) (see Note 1)	60 mA
Continuous total power dissipation, $T_C = 70^\circ\text{C}$ (see Note 2 and Figures 24 and 25)	2.86 W
Operating virtual junction temperature range, $T_J$	$-40^\circ\text{C}$ to $150^\circ\text{C}$
Operating case temperature range, $T_C$	$-40^\circ\text{C}$ to $125^\circ\text{C}$
Storage temperature range, $T_{stg}$	$-65^\circ\text{C}$ to $150^\circ\text{C}$
Lead temperature 1,6 mm (1/16 inch) from case for 10 seconds	$260^\circ\text{C}$

<sup>†</sup> Stresses beyond those listed under "absolute maximum ratings" may cause permanent damage to the device. These are stress ratings only, and functional operation of the device at these or any other conditions beyond those indicated under "recommended operating conditions" is not implied. Exposure to absolute-maximum-rated conditions for extended periods may affect device reliability.

- NOTES: 1. Pulse duration = 10 ms, duty cycle = 2%  
 2. Package is mounted in intimate contact with infinite heat sink.



**TPIC1501A**  
**QUAD AND HEX POWER DMOS ARRAY**

SLIS046A – MAY 1995 – REVISED JUNE 1996

**electrical characteristics, Q1A, Q1B, Q2A, Q2B, T<sub>C</sub> = 25°C (unless otherwise noted)**

PARAMETER		TEST CONDITIONS		MIN	TYP	MAX	UNIT
V <sub>(BR)DSX</sub>	Drain-to-source breakdown voltage	I <sub>D</sub> = 250 μA,	V <sub>GS</sub> = 0	20			V
V <sub>GS(th)</sub>	Gate-to-source threshold voltage	I <sub>D</sub> = 1 mA, See Figure 5	V <sub>DS</sub> = V <sub>GS</sub> ,	1.4	1.7	2.1	V
V <sub>GS(th)match</sub>	Gate-to-source threshold voltage matching	I <sub>D</sub> = 1 mA,	V <sub>DS</sub> = V <sub>GS</sub>	40			mV
V <sub>(BR)</sub>	Reverse drain-to-GND breakdown voltage	Drain-to-GND current = 250 μA (D1, D2)		20			V
V <sub>DS(on)</sub>	Drain-to-source on-state voltage	I <sub>D</sub> = 2 A, See Notes 3 and 4	V <sub>GS</sub> = 10 V,	0.2 0.24			V
V <sub>F</sub>	Forward on-state voltage, GND-to-V <sub>DD1</sub> , GND-to-V <sub>DD2</sub>	I <sub>D</sub> = 3 A (D1, D2) See Notes 3 and 4		1.8			V
V <sub>F(SD)</sub>	Forward on-state voltage, source-to-drain	I <sub>S</sub> = 2 A, V <sub>GS</sub> = 0, See Notes 3 and 4 and Figure 19		0.85	1.05		V
		I <sub>S</sub> = 3 A, V <sub>GS</sub> = 0, See Notes 3 and 4 and Figure 19		0.9	1.1		
I <sub>DSS</sub>	Zero-gate-voltage drain current	V <sub>DS</sub> = 16 V, V <sub>GS</sub> = 0	T <sub>C</sub> = 25°C	0.05	1		μA
			T <sub>C</sub> = 125°C	0.5	10		
I <sub>GSSF</sub>	Forward-gate current, drain short circuited to source	V <sub>GS</sub> = 16 V,	V <sub>DS</sub> = 0	10	100		nA
I <sub>GSSR</sub>	Reverse-gate current, drain short circuited to source	V <sub>SG</sub> = 16 V,	V <sub>DS</sub> = 0	10	100		nA
I <sub>lkg</sub>	Leakage current, V <sub>DD1</sub> -to-GND, V <sub>DD2</sub> -to-GND, gate shorted to source	V <sub>DGND</sub> = 16 V	T <sub>C</sub> = 25°C	0.05	1		μA
			T <sub>C</sub> = 125°C	0.5	10		
r <sub>DS(on)</sub>	Static drain-to-source on-state resistance	V <sub>GS</sub> = 10 V, I <sub>D</sub> = 2 A, See Notes 3 and 4 and Figure 9	T <sub>C</sub> = 25°C	0.1	0.12		Ω
			T <sub>C</sub> = 125°C	0.14	0.18		
			T <sub>C</sub> = 25°C	0.1	0.12		
			T <sub>C</sub> = 125°C	0.14	0.18		
g <sub>fs</sub>	Forward transconductance	V <sub>DS</sub> = 14 V, See Notes 3 and 4	I <sub>D</sub> = 1 A,	1.5	2.5		S
			I <sub>D</sub> = 1.5 A, See Notes 3 and 4 and Figure 13	2	3.1		
C <sub>iss</sub>	Short-circuit input capacitance, common source			240			pF
C <sub>oss</sub>	Short-circuit output capacitance, common source	V <sub>DS</sub> = 14 V, f = 1 MHz,	V <sub>GS</sub> = 0, See Figure 17	170			
C <sub>rss</sub>	Short-circuit reverse transfer capacitance, common source			130			
α <sub>s</sub>	Sense-FET drain current ratio	V <sub>DS</sub> = 6 V,	I <sub>D(Q2C)</sub> = 40 μA	75	130	200	

NOTES: 3. Technique should limit T<sub>J</sub> – T<sub>C</sub> to 10°C maximum.

4. These parameters are measured with voltage-sensing contacts separate from the current-carrying contacts.



# TPIC1501A

## QUAD AND HEX POWER DMOS ARRAY

SLIS046A – MAY 1995 – REVISED JUNE 1996

### source-to-drain diode characteristics, Q1A, Q2A, $T_C = 25^\circ\text{C}$

PARAMETER		TEST CONDITIONS		MIN	TYP	MAX	UNIT
$t_{rr}$	Reverse-recovery time	$I_S = 1.5\text{ A}$ , $V_{DS} = 14\text{ V}$ , See Figures 1 and 23	$V_{GS} = 0$ , $di/dt = 100\text{ A}/\mu\text{s}$ ,		70		ns
$Q_{RR}$	Total diode charge				90		nC
$t_{rr}$	Reverse-recovery time	$I_S = 2\text{ A}$ , $V_{DS} = 14\text{ V}$ ,	$V_{GS} = 0$ , $di/dt = 100\text{ A}/\mu\text{s}$		75		ns
$Q_{RR}$	Total diode charge				110		nC

### resistive-load switching characteristics, Q1A, Q1B, Q2A, Q2B, $T_C = 25^\circ\text{C}$

PARAMETER		TEST CONDITIONS			MIN	TYP	MAX	UNIT
$t_{d(on)}$	Turn-on delay time	$V_{DD} = 14\text{ V}$ , $t_{dis} = 10\text{ ns}$ ,	$R_L = 9.3\ \Omega$ , See Figure 3	$t_{en} = 10\text{ ns}$ ,		20		ns
$t_{d(off)}$	Turn-off delay time					30		
$t_r$	Rise time					15		
$t_f$	Fall time					25		
$Q_g$	Total gate charge	$V_{DS} = 14\text{ V}$ , See Figure 4	$I_D = 1.5\text{ A}$ ,	$V_{GS} = 10\text{ V}$ ,		5.6	7	nC
$Q_{gs(th)}$	Threshold gate-to-source charge					0.8	1	
$Q_{gd}$	Gate-to-drain charge					1.4	1.75	
$L_{(drain)}$	Internal drain inductance					5		nH
$L_{(source)}$	Internal source inductance					5		
$r_{(gate)}$	Internal gate resistance					0.25		$\Omega$



**TPIC1501A**  
**QUAD AND HEX POWER DMOS ARRAY**

SLIS046A – MAY 1995 – REVISED JUNE 1996

**electrical characteristics, Q3A, Q3B, Q4A, Q4B, Q5A, Q5B,  $T_C = 25^\circ\text{C}$  (unless otherwise noted)**

PARAMETER		TEST CONDITIONS		MIN	TYP	MAX	UNIT
$V_{(BR)DSX}$	Drain-to-source breakdown voltage	$I_D = 250\ \mu\text{A}$ ,	$V_{GS} = 0\ \text{V}$	20			V
$V_{GS(th)}$	Gate-to-source threshold voltage	$I_D = 1\ \text{mA}$ , See Figure 6	$V_{DS} = V_{GS}$ ,	1.4	1.7	2.1	V
$V_{GS(th)match}$	Gate-to-source threshold voltage matching	$I_D = 1\ \text{mA}$ ,	$V_{DS} = V_{GS}$	40			mV
$V_{(BR)}$	Reverse drain-to-GND breakdown voltage	Drain-to-GND current = $250\ \mu\text{A}$ (D3)		20			V
$V_{DS(on)}$	Drain-to-source on-state voltage	$I_D = 1.5\ \text{A}$ , See Notes 3 and 4	$V_{GS} = 10\ \text{V}$ ,	0.6 0.68			V
$V_F$	Forward on-state voltage, GND-to- $V_{DD3}$	$I_D = 1.5\ \text{A}$ (D3) See Notes 3 and 4		1.7			V
$V_{F(SD)}$	Forward on-state voltage, source-to-drain	$I_S = 1.5\ \text{A}$ , $V_{GS} = 0$ , See Notes 3 and 4 and Figure 20		1 1.2			V
		$I_S = 2\ \text{A}$ , $V_{GS} = 0$ , See Notes 3 and 4 and Figure 20		1.1 1.3			
$I_{DSS}$	Zero-gate-voltage drain current	$V_{DS} = 16\ \text{V}$ , $V_{GS} = 0$	$T_C = 25^\circ\text{C}$	0.05 1		$\mu\text{A}$	
			$T_C = 125^\circ\text{C}$	0.5 10			
$I_{GSSF}$	Forward-gate current, drain short circuited to source	$V_{GS} = 16\ \text{V}$ ,	$V_{DS} = 0$	10 100		nA	
$I_{GSSR}$	Reverse-gate current, drain short circuited to source	$V_{SG} = 16\ \text{V}$ ,	$V_{DS} = 0$	10 100		nA	
$I_{lkg}$	Leakage current, $V_{DD3}$ -to-GND, gate shorted to source	$V_{DGND} = 16\ \text{V}$	$T_C = 25^\circ\text{C}$	0.05 1		$\mu\text{A}$	
			$T_C = 125^\circ\text{C}$	0.5 10			
$r_{DS(on)}$	Static drain-to-source on-state resistance	$V_{GS} = 10\ \text{V}$ , $I_D = 0.3\ \text{A}$ , See Notes 3 and 4 and Figure 10	$T_C = 25^\circ\text{C}$	0.35 0.39		$\Omega$	
			$T_C = 125^\circ\text{C}$	0.5 0.56			
			$T_C = 25^\circ\text{C}$	0.4 0.45			
			$T_C = 125^\circ\text{C}$	0.56 0.65			
$g_{fs}$	Forward transconductance	$V_{DS} = 14\ \text{V}$ , See Notes 3 and 4	$I_D = 500\ \text{mA}$ ,	0.3 0.8		S	
			$I_D = 750\ \text{mA}$ , See Notes 3 and 4 and Figure 14	0.4 0.93			
$C_{iss}$	Short-circuit input capacitance, common source			96		pF	
$C_{oss}$	Short-circuit output capacitance, common source	$V_{DS} = 14\ \text{V}$ , $f = 1\ \text{MHz}$ ,	$V_{GS} = 0$ , See Figure 18	98			
$C_{rss}$	Short-circuit reverse transfer capacitance, common source			65			

- NOTES: 3. Technique should limit  $T_J - T_C$  to  $10^\circ\text{C}$  maximum.  
4. These parameters are measured with voltage-sensing contacts separate from the current-carrying contacts.



# TPIC1501A

## QUAD AND HEX POWER DMOS ARRAY

SLIS046A – MAY 1995 – REVISED JUNE 1996

### source-to-drain diode characteristics, Q3A, Q4A, Q5A, $T_C = 25^\circ\text{C}$

PARAMETER		TEST CONDITIONS		MIN	TYP	MAX	UNIT
$t_{rr}$	Reverse-recovery time	$I_S = 750\text{ mA}$ , $V_{DS} = 14\text{ V}$ , See Figures 2 and 23	$V_{GS} = 0$ , $di/dt = 100\text{ A}/\mu\text{s}$ ,		60		ns
$Q_{RR}$	Total diode charge				55		nC
$t_{rr}$	Reverse-recovery time	$I_S = 1.5\text{ A}$ , $V_{DS} = 14\text{ V}$ ,	$V_{GS} = 0$ , $di/dt = 100\text{ A}/\mu\text{s}$		120		ns
$Q_{RR}$	Total diode charge				150		nC

### resistive-load switching characteristics, Q3A, Q3B, Q4A, Q4B, Q5A, Q5B, $T_C = 25^\circ\text{C}$

PARAMETER		TEST CONDITIONS			MIN	TYP	MAX	UNIT
$t_{d(on)}$	Turn-on delay time	$V_{DD} = 14\text{ V}$ , $t_{dis} = 10\text{ ns}$ ,	$R_L = 18.7\ \Omega$ , See Figure 3	$t_{en} = 10\text{ ns}$ ,		18		ns
$t_{d(off)}$	Turn-off delay time					25		
$t_r$	Rise time					13		
$t_f$	Fall time					20		
$Q_g$	Total gate charge	$V_{DS} = 14\text{ V}$ , See Figure 4	$I_D = 750\text{ mA}$ ,	$V_{GS} = 10\text{ V}$ ,		1.6	2	nC
$Q_{gs(th)}$	Threshold gate-to-source charge					0.26	0.32	
$Q_{gd}$	Gate-to-drain charge					0.42	0.52	
$L_{(drain)}$	Internal drain inductance					5		nH
$L_{(source)}$	Internal source inductance					5		
$r_{(gate)}$	Internal gate resistance					0.25		$\Omega$

### thermal resistance

PARAMETER		TEST CONDITIONS		MIN	TYP	MAX	UNIT
$R_{\theta JA}$	Junction-to-ambient thermal resistance	See Notes 5 and 8			90		$^\circ\text{C}/\text{W}$
$R_{\theta JB}$	Junction-to-board thermal resistance	See Notes 6 and 8			38		
$R_{\theta JP}$	Junction-to-pin thermal resistance	See Notes 7 and 8			28		

- NOTES:
- Package is mounted on a FR4 printed-circuit board with no heat sink.
  - Package is mounted on a 24 in<sup>2</sup>, 4-layer FR4 printed-circuit board.
  - Package is mounted in intimate contact with infinite heat sink.
  - All outputs have equal power.

PARAMETER MEASUREMENT INFORMATION

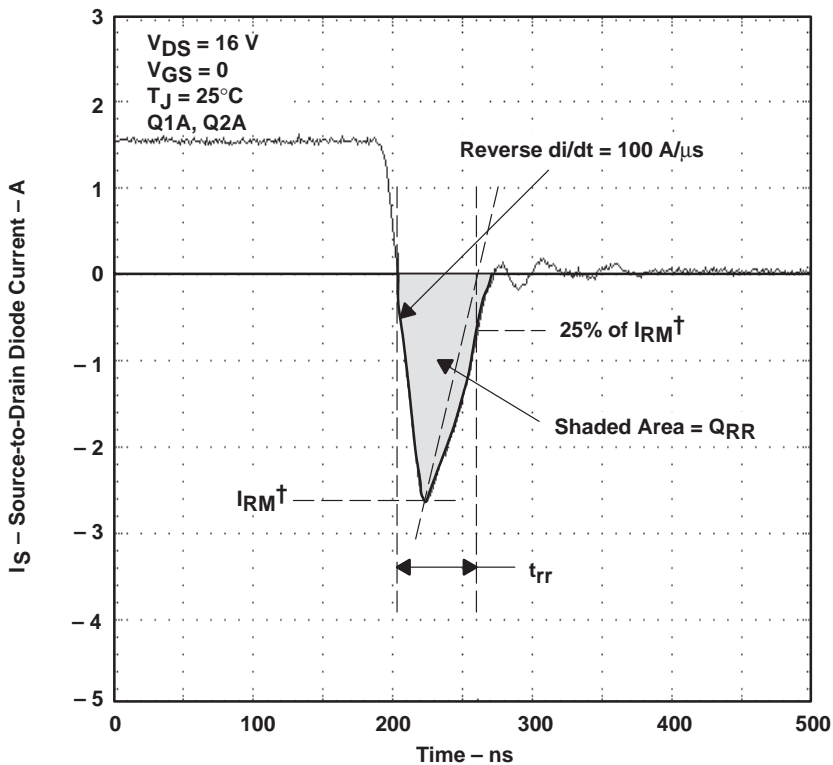

$^\dagger I_{RM}$  = maximum recovery current

Figure 1. Reverse-Recovery-Current Waveform of Source-to-Drain Diodes

# TPIC1501A QUAD AND HEX POWER DMOS ARRAY

SLIS046A – MAY 1995 – REVISED JUNE 1996

## PARAMETER MEASUREMENT INFORMATION

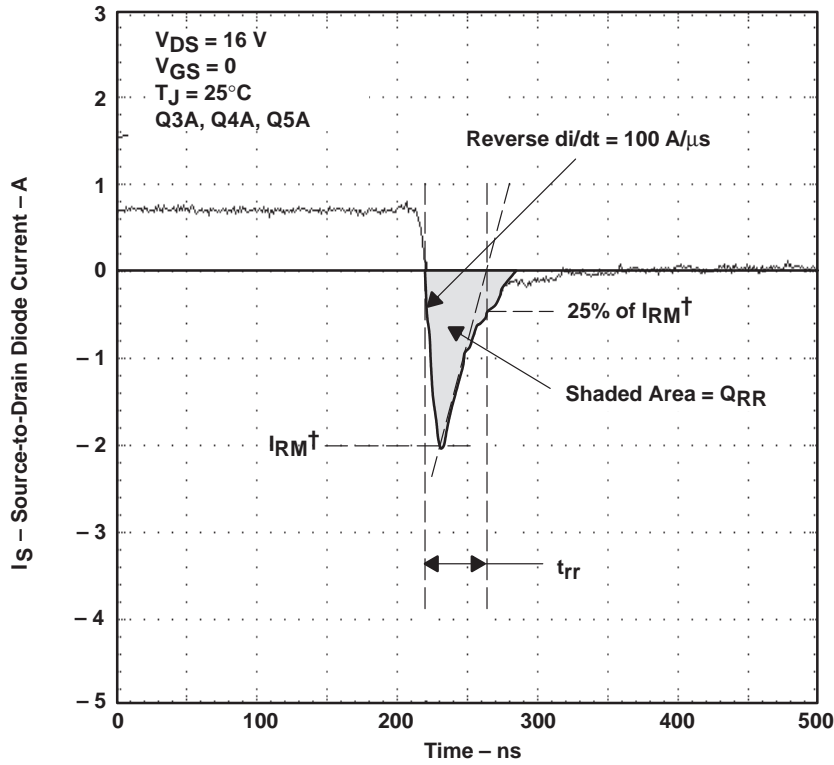

$^\dagger I_{RM}$  = maximum recovery current

Figure 2. Reverse-Recovery-Current Waveform of Source-to-Drain Diodes

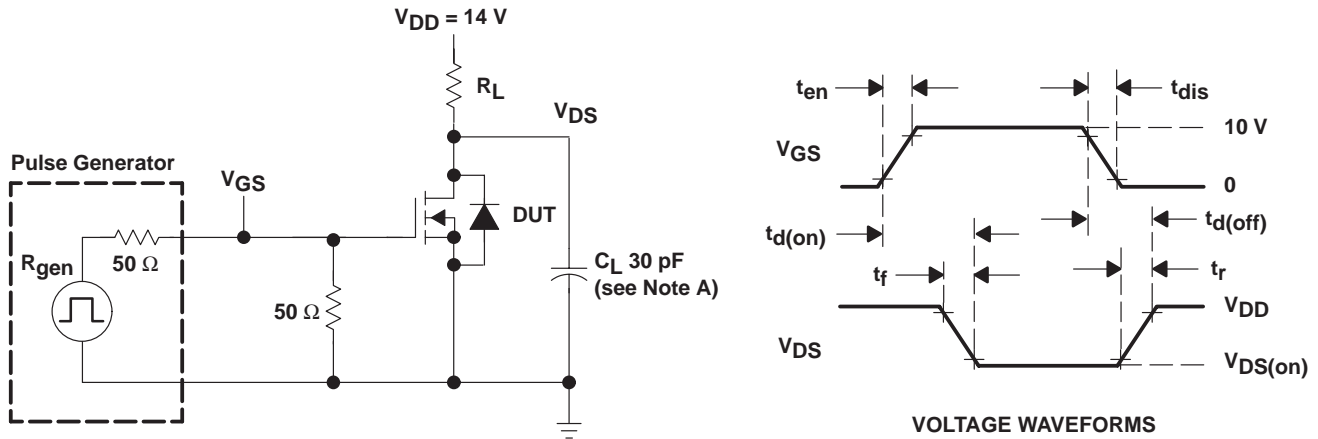

TEST CIRCUIT

NOTE A:  $C_L$  includes probe and jig capacitance.

Figure 3. Resistive-Switching Test Circuit and Voltage Waveforms



PARAMETER MEASUREMENT INFORMATION

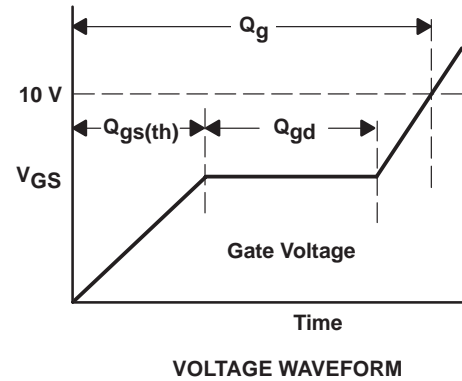
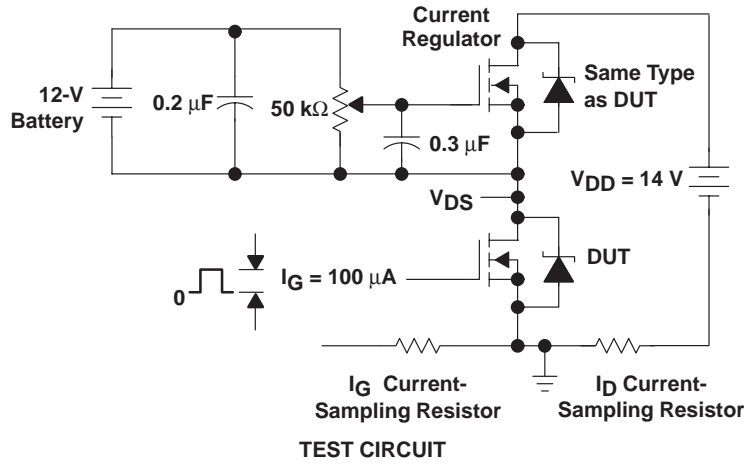

Figure 4. Gate-Charge Test Circuit and Voltage Waveform

TYPICAL CHARACTERISTICS

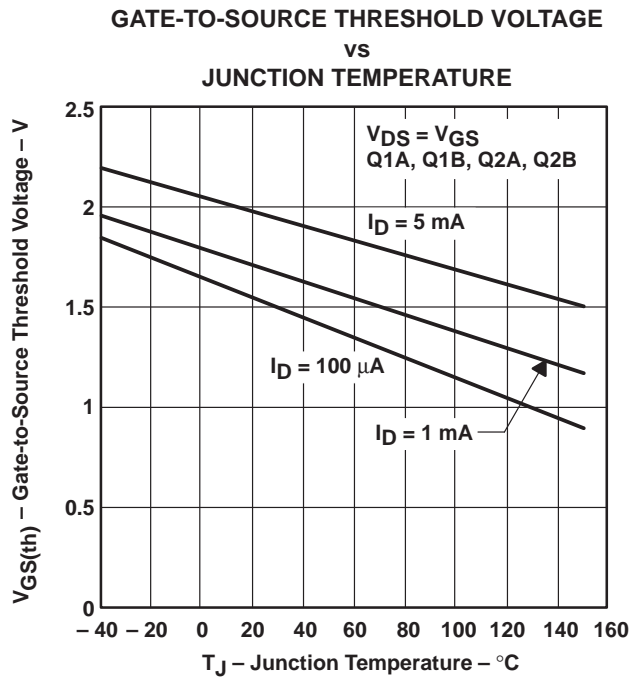

Figure 5

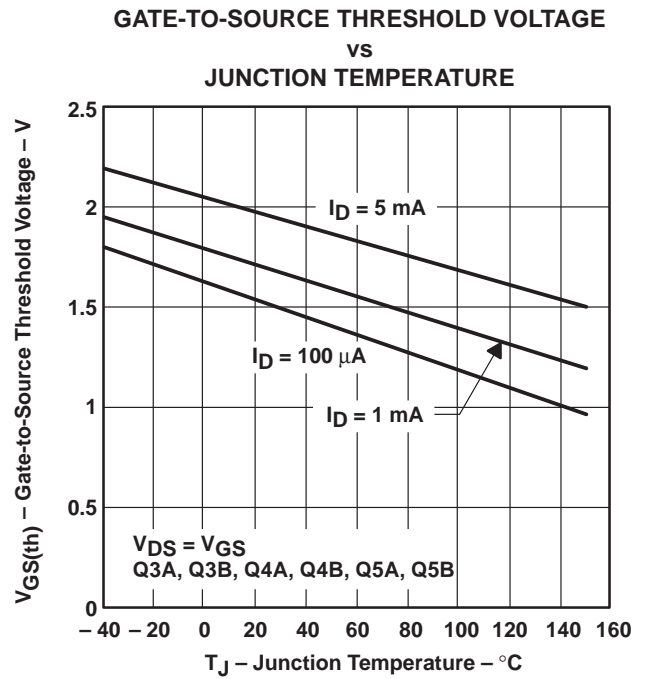

Figure 6

# TPIC1501A QUAD AND HEX POWER DMOS ARRAY

SLIS046A – MAY 1995 – REVISED JUNE 1996

## TYPICAL CHARACTERISTICS

STATIC DRAIN-TO-SOURCE ON-STATE RESISTANCE  
vs  
JUNCTION TEMPERATURE

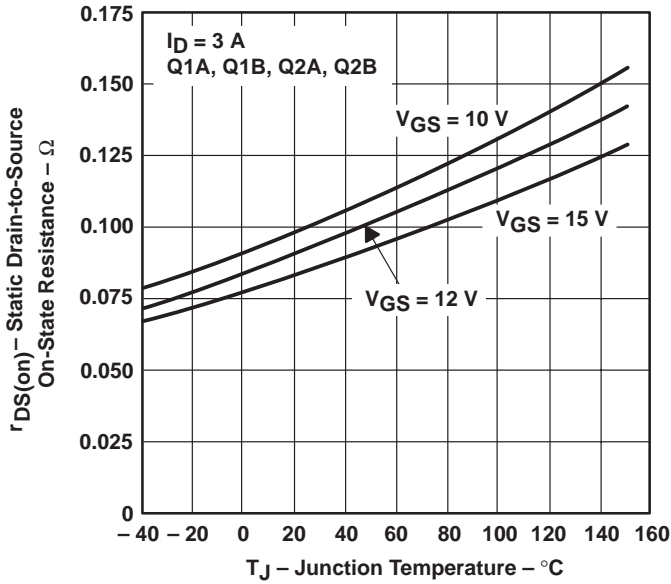

Figure 7

STATIC DRAIN-TO-SOURCE ON-STATE RESISTANCE  
vs  
JUNCTION TEMPERATURE

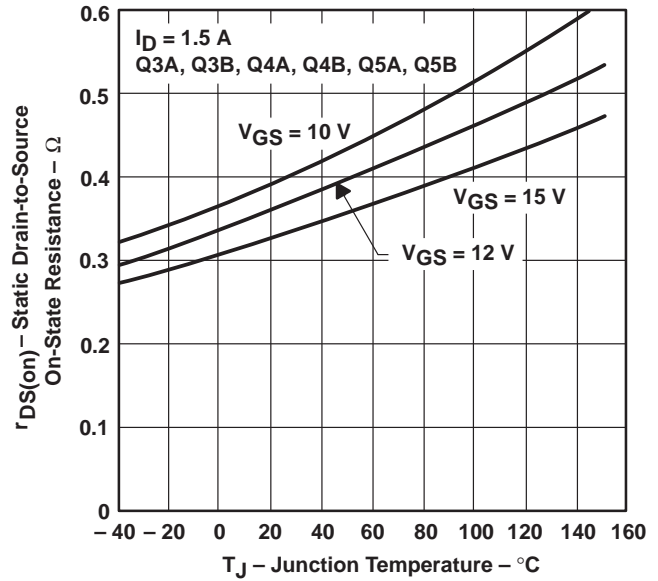

Figure 8

STATIC DRAIN-TO-SOURCE ON-STATE RESISTANCE  
vs  
DRAIN CURRENT

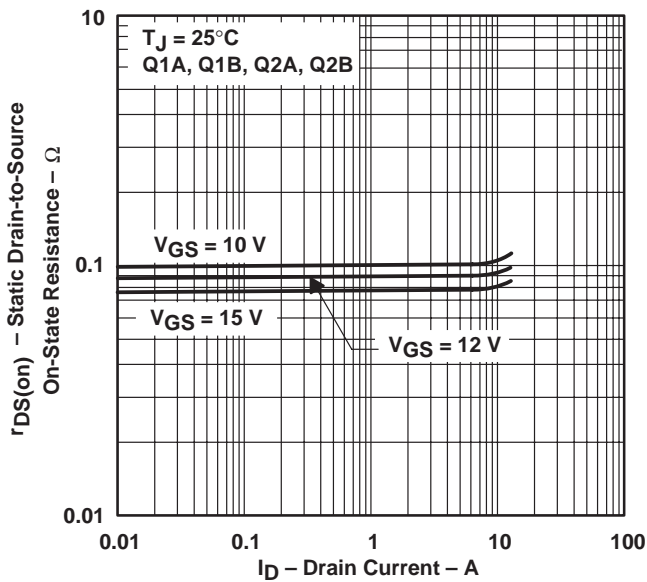

Figure 9

STATIC DRAIN-TO-SOURCE ON-STATE RESISTANCE  
vs  
DRAIN CURRENT

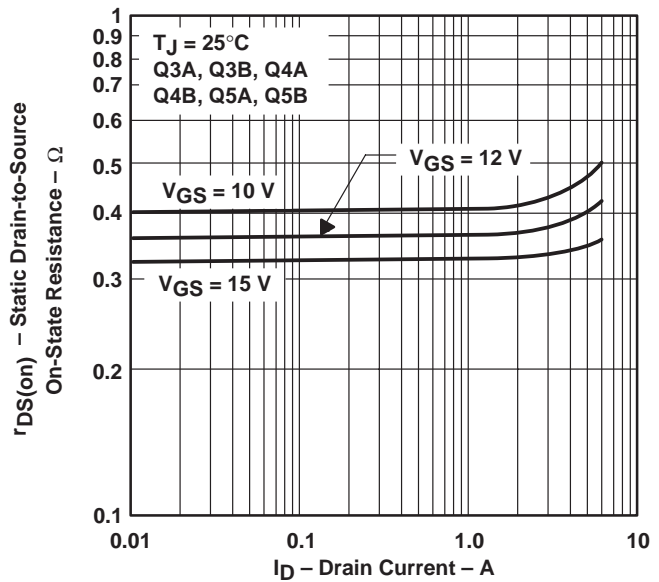

Figure 10

TYPICAL CHARACTERISTICS

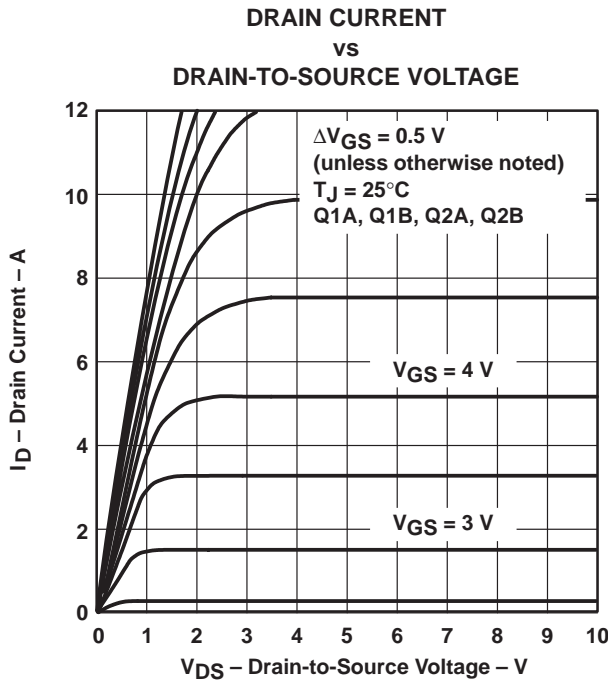

Figure 11

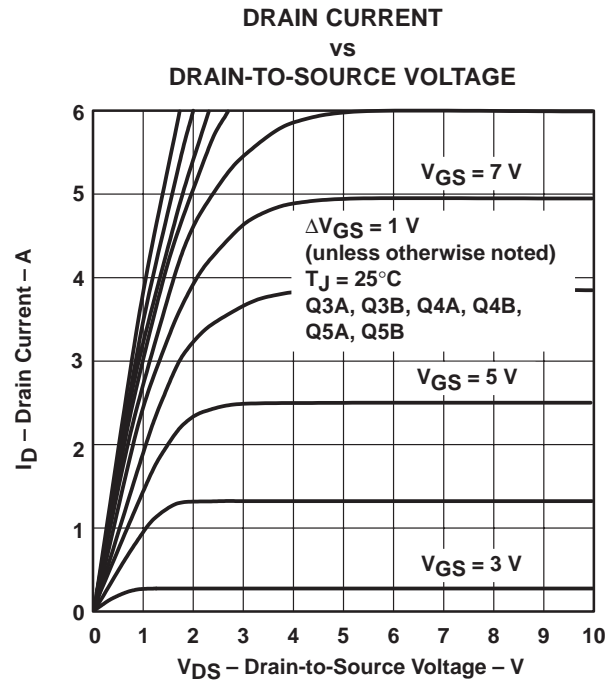

Figure 12

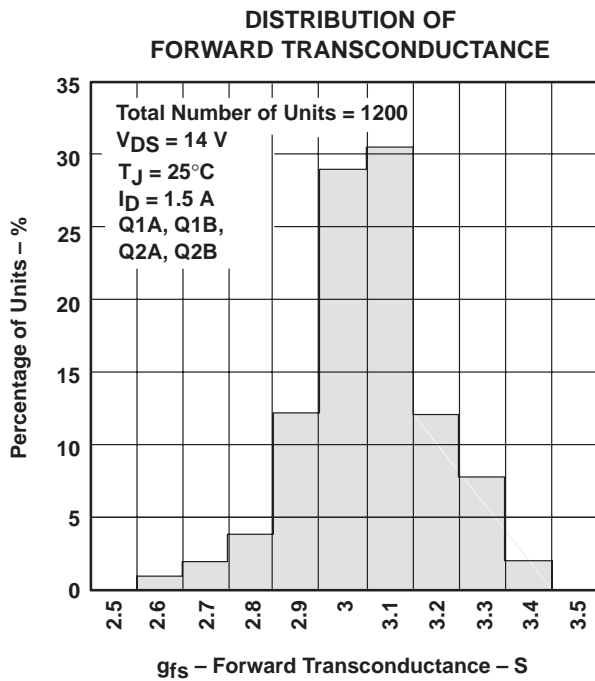

Figure 13

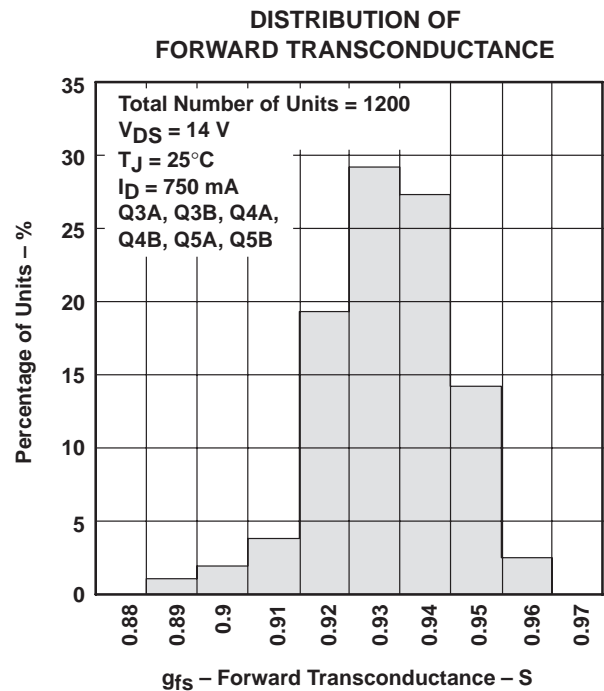

Figure 14

# TPIC1501A QUAD AND HEX POWER DMOS ARRAY

SLIS046A – MAY 1995 – REVISED JUNE 1996

## TYPICAL CHARACTERISTICS

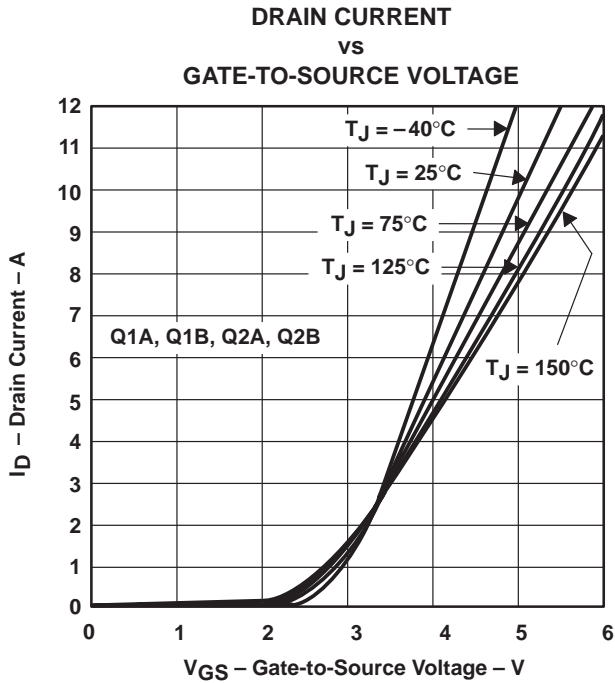

Figure 15

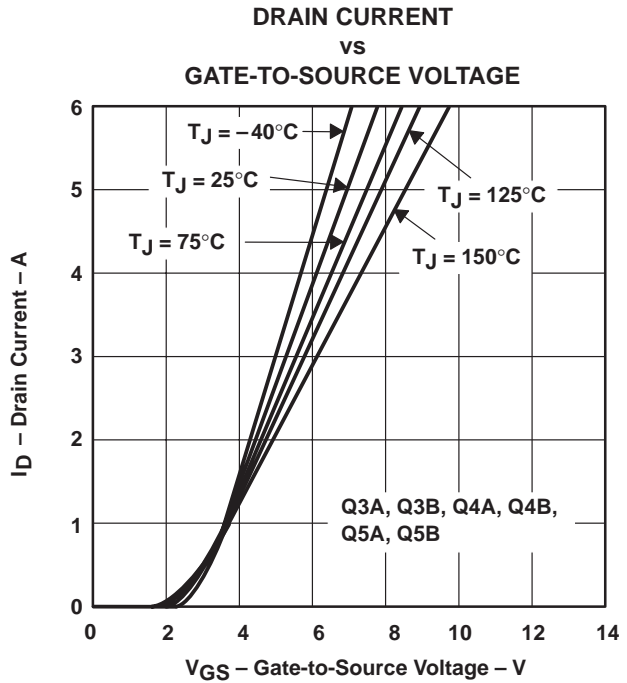

Figure 16

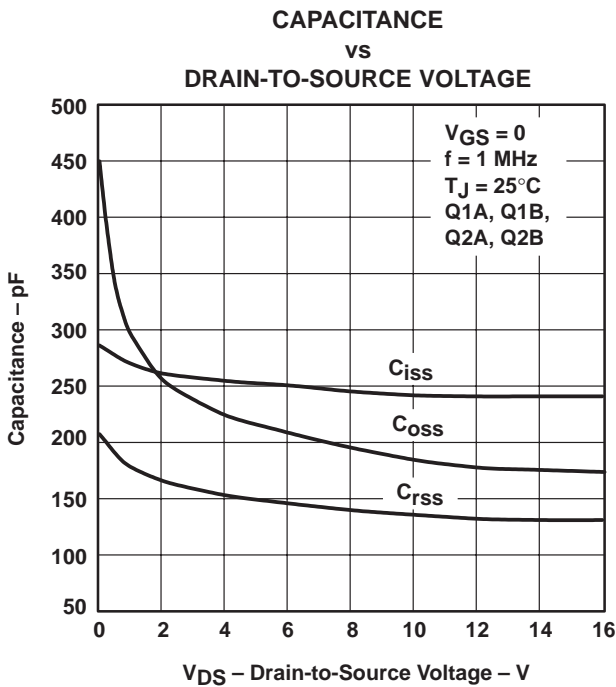

Figure 17

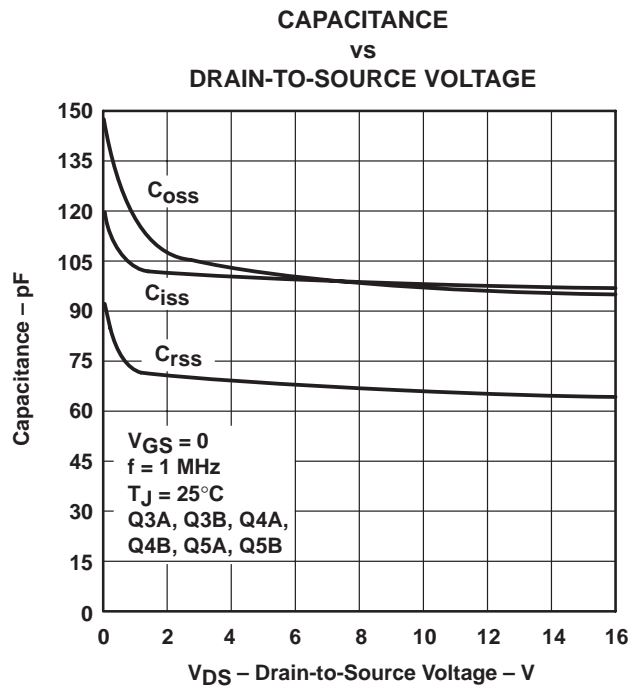

Figure 18



TYPICAL CHARACTERISTICS

SOURCE-TO-DRAIN DIODE CURRENT  
 vs  
 SOURCE-TO-DRAIN VOLTAGE

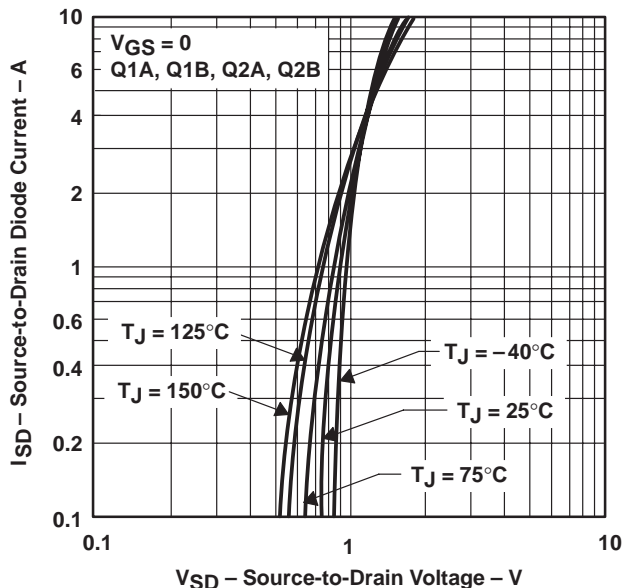

Figure 19

SOURCE-TO-DRAIN DIODE CURRENT  
 vs  
 SOURCE-TO-DRAIN VOLTAGE

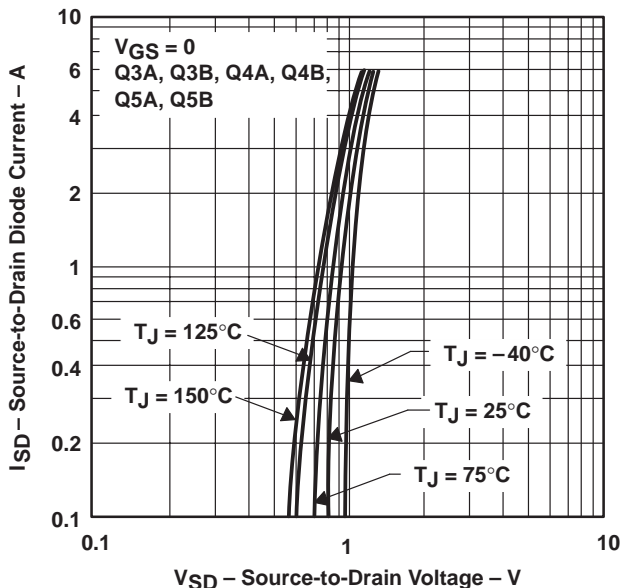

Figure 20

DRAIN-TO-SOURCE VOLTAGE AND  
 GATE-TO-SOURCE VOLTAGE  
 vs  
 GATE CHARGE

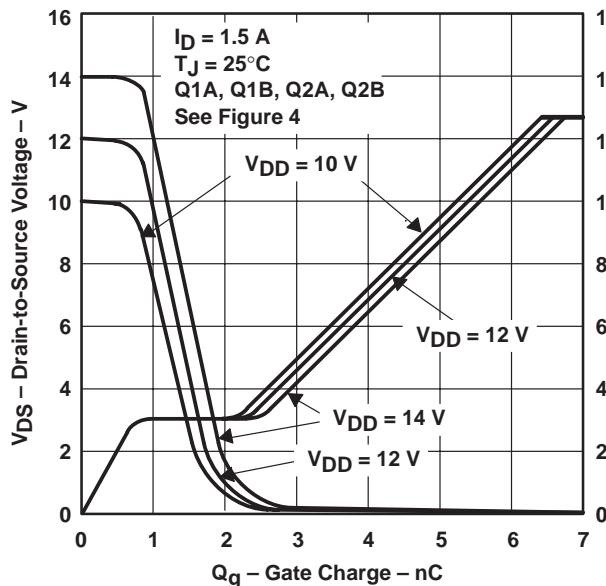

Figure 21

DRAIN-TO-SOURCE VOLTAGE AND  
 GATE-TO-SOURCE VOLTAGE  
 vs  
 GATE CHARGE

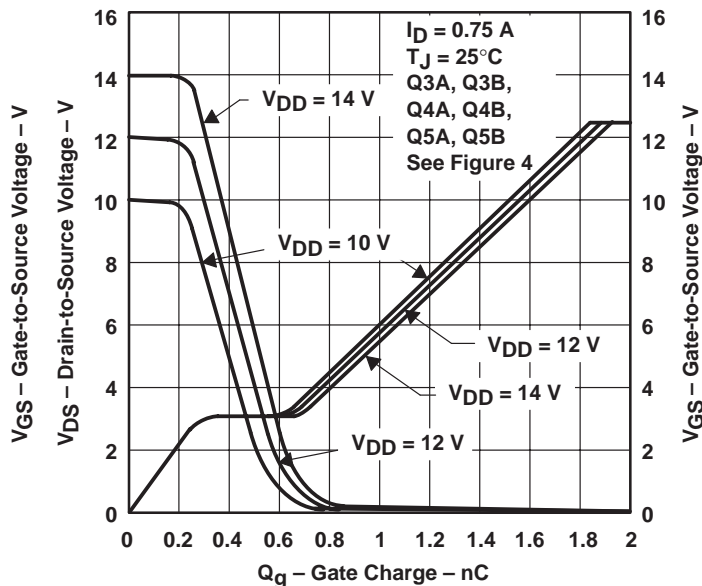

Figure 22

# TPIC1501A QUAD AND HEX POWER DMOS ARRAY

SLIS046A – MAY 1995 – REVISED JUNE 1996

## TYPICAL CHARACTERISTICS

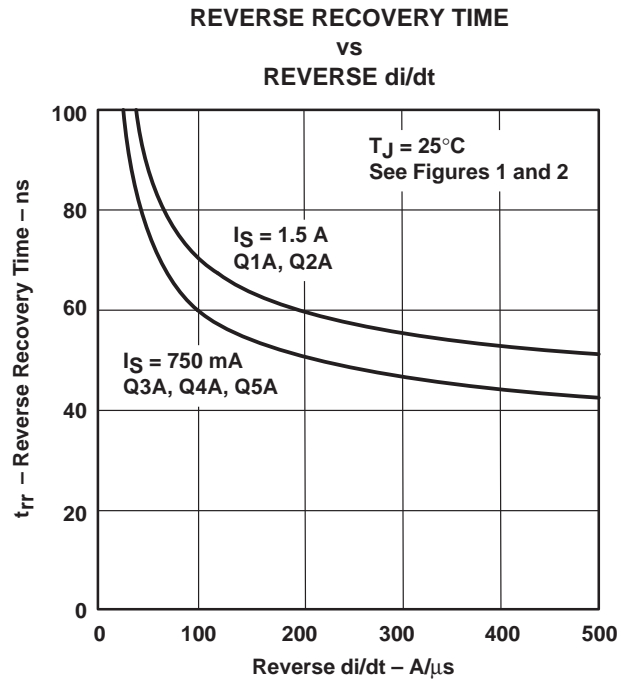

Figure 23

THERMAL INFORMATION

MAXIMUM DRAIN CURRENT  
 vs  
 DRAIN-TO-SOURCE VOLTAGE

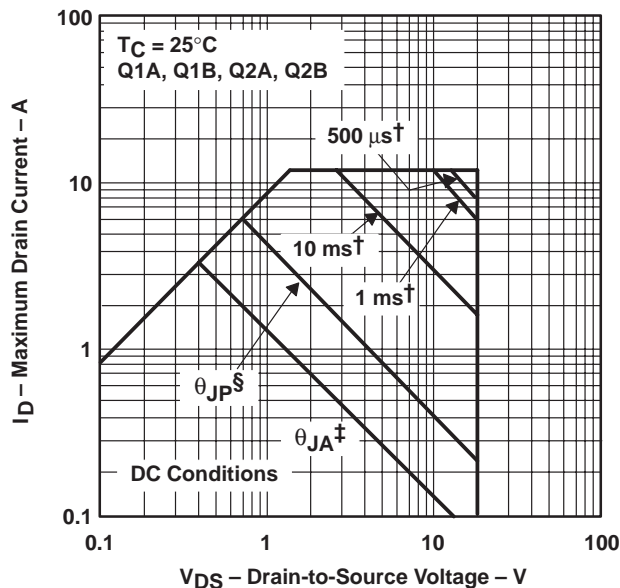

Figure 24

MAXIMUM DRAIN CURRENT  
 vs  
 DRAIN-TO-SOURCE VOLTAGE

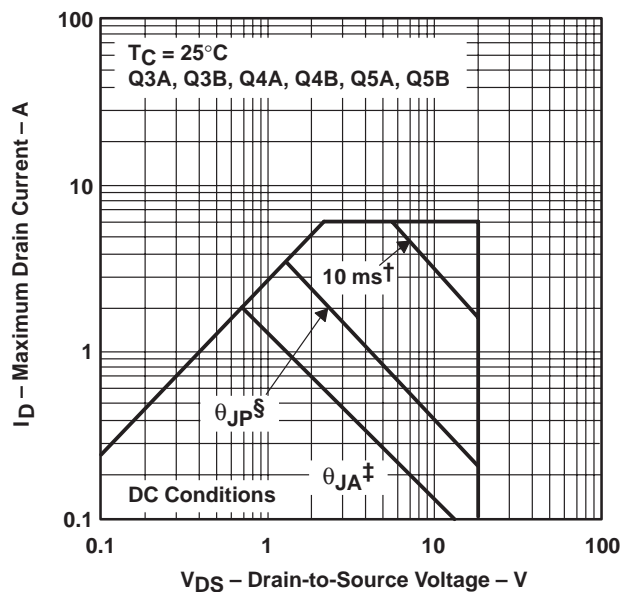

Figure 25

† Less than 10% duty cycle

‡ Device is mounted on a 24 in<sup>2</sup>, 4 layer FR4 printed-circuit board.

§ Device is mounted in intimate contact with infinite heat sink.

# TPIC1501A QUAD AND HEX POWER DMOS ARRAY

SLIS046A – MAY 1995 – REVISED JUNE 1996

## THERMAL INFORMATION DW PACKAGE† JUNCTION-TO-BOARD THERMAL RESISTANCE VS PULSE DURATION

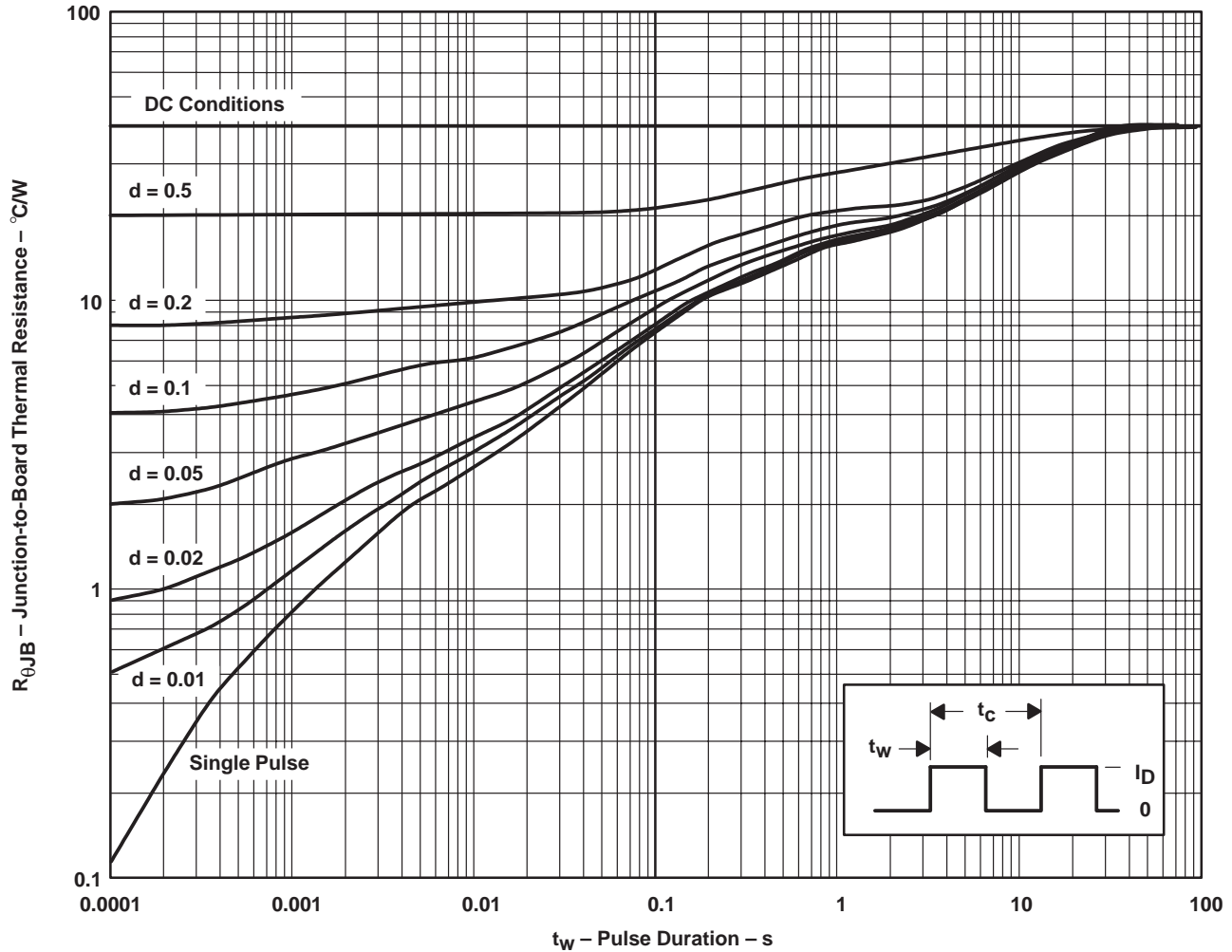

† Device is mounted on 24 in<sup>2</sup>, 4-layer FR4 printed-circuit board with no heat sink.

NOTE A:  $Z_{\theta B}(t) = r(t) R_{\theta JB}$   
 $t_w$  = pulse duration  
 $t_c$  = cycle time  
 $d$  = duty cycle =  $t_w/t_c$

Figure 26



## IMPORTANT NOTICE

Texas Instruments and its subsidiaries (TI) reserve the right to make changes to their products or to discontinue any product or service without notice, and advise customers to obtain the latest version of relevant information to verify, before placing orders, that information being relied on is current and complete. All products are sold subject to the terms and conditions of sale supplied at the time of order acknowledgement, including those pertaining to warranty, patent infringement, and limitation of liability.

TI warrants performance of its semiconductor products to the specifications applicable at the time of sale in accordance with TI's standard warranty. Testing and other quality control techniques are utilized to the extent TI deems necessary to support this warranty. Specific testing of all parameters of each device is not necessarily performed, except those mandated by government requirements.

CERTAIN APPLICATIONS USING SEMICONDUCTOR PRODUCTS MAY INVOLVE POTENTIAL RISKS OF DEATH, PERSONAL INJURY, OR SEVERE PROPERTY OR ENVIRONMENTAL DAMAGE ("CRITICAL APPLICATIONS"). TI SEMICONDUCTOR PRODUCTS ARE NOT DESIGNED, AUTHORIZED, OR WARRANTED TO BE SUITABLE FOR USE IN LIFE-SUPPORT DEVICES OR SYSTEMS OR OTHER CRITICAL APPLICATIONS. INCLUSION OF TI PRODUCTS IN SUCH APPLICATIONS IS UNDERSTOOD TO BE FULLY AT THE CUSTOMER'S RISK.

In order to minimize risks associated with the customer's applications, adequate design and operating safeguards must be provided by the customer to minimize inherent or procedural hazards.

TI assumes no liability for applications assistance or customer product design. TI does not warrant or represent that any license, either express or implied, is granted under any patent right, copyright, mask work right, or other intellectual property right of TI covering or relating to any combination, machine, or process in which such semiconductor products or services might be or are used. TI's publication of information regarding any third party's products or services does not constitute TI's approval, warranty or endorsement thereof.