

TPIC2801 OCTAL INTELLIGENT-POWER SWITCH WITH SERIAL INPUT

SLIS008 – D3282, AUGUST 1989 – REVISED JUNE 1990

- 8-Bit Serial-In Parallel-Out Driver
- 1-A Output Current Capability Per Channel or 8-A Total Current
- Overcurrent Limiting and Out-of-Saturation Voltage Protection on Driver Outputs
- Contains Eight Open-Collector Saturating Sink Outputs With Low On-State Voltage
- High-Impedance Inputs With Hysteresis Are Compatible With TTL or CMOS Levels
- Very Low Standby Power
20 mW Typical
- Status of Output Drivers May Be Monitored at Serial Output
- 3-State Serial Output Permits Serial Cascading or Wire-AND Device Connections
- 25-V Transient Clamping With Inductive Switching on Outputs, 40-mJ Rating Per Driver Output

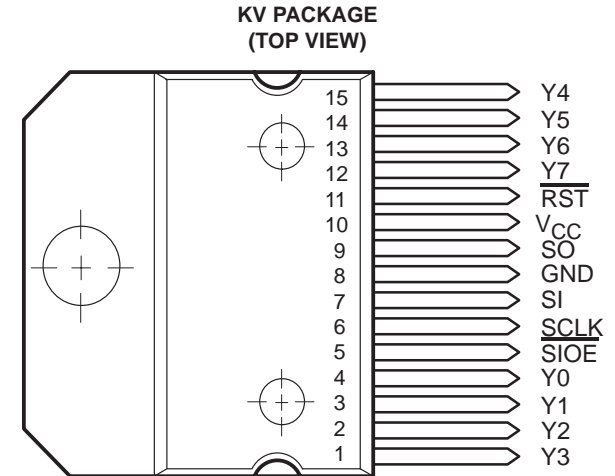

description

The TPIC2801 octal intelligent-power switch is a monolithic BIFMOS† integrated circuit designed to sink currents up to 1 A at 30 V simultaneously at each of eight driver outputs under serial input data control. Status of the individual driver outputs is available in serial data format. The driver outputs have overcurrent limiting and out-of-saturation voltage protection features. Applications include driving solenoids, relays, dc motors, lamps, and other medium-current or high-voltage loads.

The device contains an 8-bit serial-in, parallel-out shift register that feeds an 8-bit parallel latch, which independently controls each of the eight Y-output drivers.

Data is entered into the device serially via the serial input (SI) and goes directly into the lowest bit (0) of the shift register. Using proper timing signals, the input data is passed to the corresponding output latch and output driver. A logic-high bit at SI turns the corresponding output driver (Y_n) off. A logic-low bit at SI turns the corresponding output driver on. Serial data is transferred into SI on the high-to-low transition of serial clock (SCLK) input in 8-bit bytes with data for the Y7 output (most significant bit) first and data for Y0 output (least significant bit) last. Both SI and SCLK are active when serial input-output enable ($\overline{\text{SIOE}}$) input is low and are disabled when $\overline{\text{SIOE}}$ is high.

Each driver output is monitored by a voltage comparator that compares the Y-output voltage level with an internal out-of-saturation threshold voltage reference level. The logic state of the comparator output is dependent upon whether the Y output is greater or smaller than the reference voltage level. An activated driver output is unlatched and turned off when the output voltage exceeds the out-of-saturation threshold voltage level except when the internal unlatch enable is low and disabled. The high-to-low transition of $\overline{\text{SIOE}}$ transfers the logic state of the comparator output to the shift register.

† BIFMOS – Bipolar, double-diffused, N-channel and P-channel MOS transistors on same chip. This is a patented process.

TPIC2801 OCTAL INTELLIGENT-POWER SWITCH WITH SERIAL INPUT

SLIS008 – D3282, AUGUST 1989 – REVISED JUNE 1990

logic symbol†

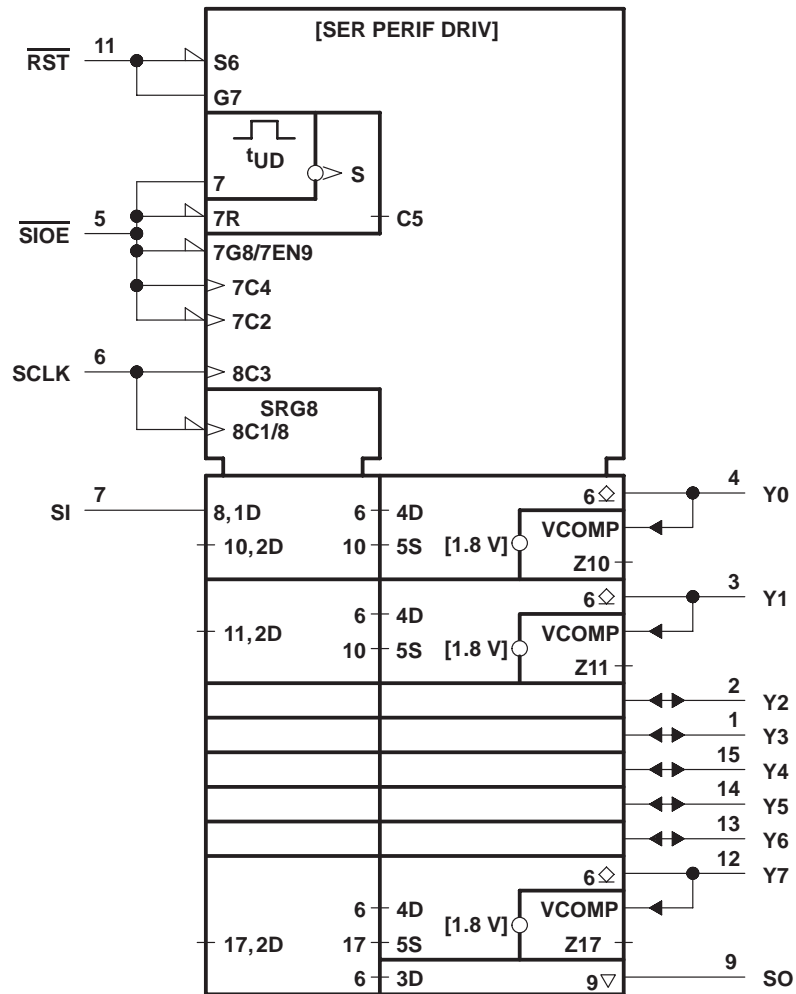

† This symbol is in accordance with ANSI/IEEE Std. 91-1984 and IEC Publication 617-12.

TPIC2801
OCTAL INTELLIGENT-POWER SWITCH
WITH SERIAL INPUT

SLIS008 – D3282, AUGUST 1989 – REVISED JUNE 1990

logic diagram (positive logic)

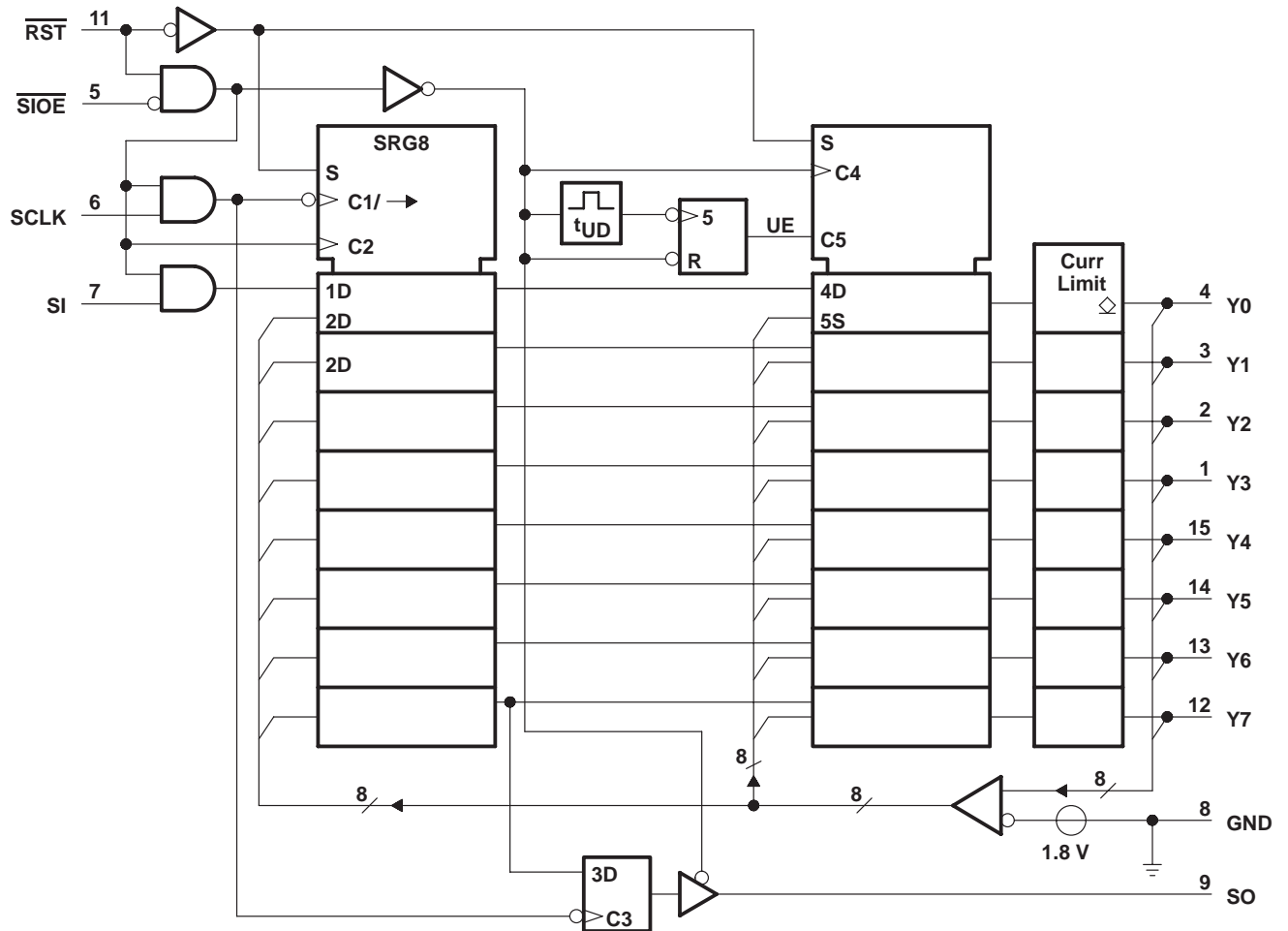

TPIC2801

OCTAL INTELLIGENT-POWER SWITCH WITH SERIAL INPUT

SLIS008 – D3282, AUGUST 1989 – REVISED JUNE 1990

Terminal Functions

PIN NAME NO.	I/O	DESCRIPTION
GND 8		Ground. Common return for entire chip. The current from this terminal is potentially as high as 4 A if all outputs are on. GND is used for both logic and power circuits.
$\overline{\text{RST}}$ 11	I	Reset. An asynchronous reset is provided for the shift register and the parallel latches. This terminal is active when low and has no internal pullup. When active, it causes the power outputs to turn off. A power-on clear can be implemented using an RC network to V_{CC} .
SCLK 6	I	Serial clock. This terminal clocks the shift register. The serial output (SO) changes state on the rising edge of SCLK and serial input (SI) data is accepted on the falling edge.
SI 7	I	Serial input. This terminal is the serial data input. A high on this terminal programs a particular output off, and a low turns it on.
$\overline{\text{SIOE}}$ 5	I	Serial input-output enable. Data is transferred from the shift registers to the power outputs on the rising edge of this signal. The falling edge of this signal parallel loads the output voltage sense bits from the power output stages into the shift register. The output driver for SO is enabled when this terminal is low, provided $\overline{\text{RST}}$ is high.
SO 9	O	Serial output. This terminal is the serial 3-state output from the shift register and is in a high-impedance state when $\overline{\text{SIOE}}$ is high or $\overline{\text{RST}}$ is low. A high for a data bit on this terminal indicates that the corresponding power output (Y_n) is high. This means that the output was programmed to be off the last time a byte was input to the device or that the output faulted and was latched off by the output voltage-sense indicator. A low on this output indicates that the corresponding power output (Y_n) is low (on output stage or open-circuit condition).
V_{CC} 10		5-V supply voltage
Y0 4 Y1 3 Y2 2 Y3 1 Y4 15 Y5 14 Y6 13 Y7 12	O	Power outputs. These outputs are provided with current limiting and voltage sense for fault indication and protection. The nominal load current for these outputs is 500 mA, and the current limiting is set to a minimum of 1.2 A. The active-low outputs also have voltage clamps set at about 35 V for recirculation of inductive load current. Internal 90-k Ω pull-down resistors are provided at each output. These resistors hold the output low during an open-circuit condition.

schematic of inputs and outputs

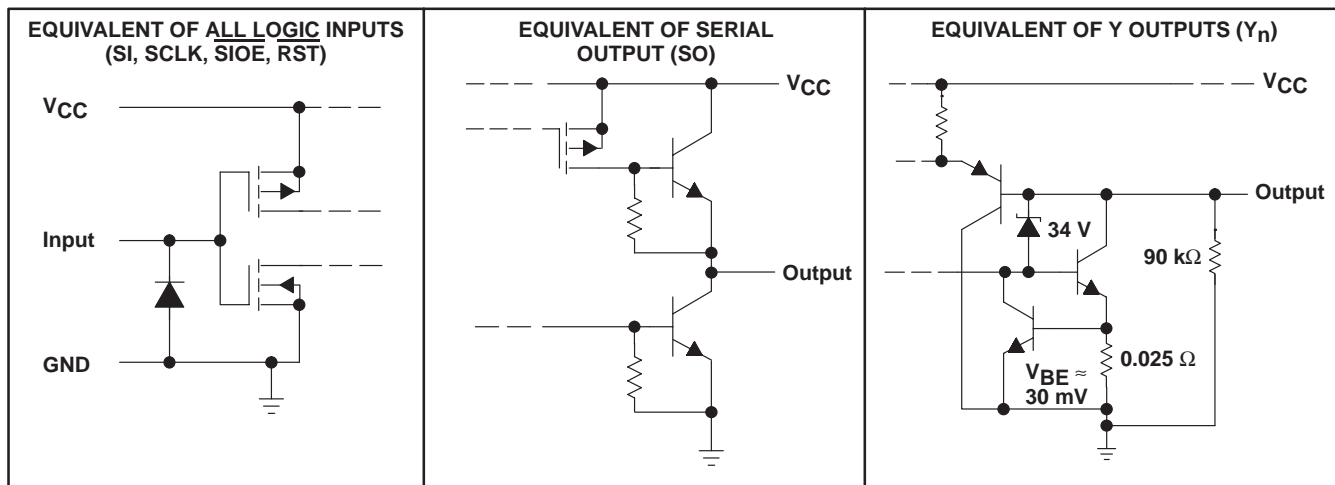

All resistor and voltage values shown are nominal.

TPIC2801
OCTAL INTELLIGENT-POWER SWITCH
WITH SERIAL INPUT

SLIS008 – D3282, AUGUST 1989 – REVISED JUNE 1990

absolute maximum ratings over operating temperature range (unless otherwise noted)

Supply voltage range, V_{CC} (see Note 1)	– 0.3 V to 7 V
Input voltage, V_I	7 V
Output voltage range, V_O	– 0.3 V to 7 V
Input current, I_I	–15 mA
Peak output sink current at Y, I_O repetitive, $t_W = 10$ ms, duty cycle = 50%, (see Notes 2 and 3)	internally limited
Continuous output current at Y, I_O (see Note 3)	1 A
Peak current through GND: Nonrepetitive $t_W = 0.2$ ms	– 8 A
Repetitive, $t_W = 10$ ms, duty cycle = 50%	– 6 A
Continuous current through GND	– 4.5 A
Output clamp energy, E_{OK} (after turning off $I_{O(on)} = 0.5$ A)	40 mJ
Continuous dissipation at (or below) $T_A = 25^\circ\text{C}$ (see Note 4)	3.575 W
Continuous dissipation at (or below) $T_C = 75^\circ\text{C}$ (see Note 4)	25 W
Operating case or virtual junction temperature range	– 55°C to 150°C
Storage temperature range	– 65°C to 150°C
Lead temperature 1, 6 mm (1/16 inch) from case for 10 seconds	260°C

- NOTES: 1. All voltage values are with respect to network GND.
2. Each Y output is individually current limited with a typical overcurrent limit of about 1.4 A.
3. Multiple Y outputs of this device can conduct rated current simultaneously; however, power dissipation (average) over a short time interval must fall within the continuous dissipation range and the GND current must fall within the GND-terminal current range.
4. For operation above 25°C free-air temperature, derate linearly at the rate of 28.6 mW/°C. For operation above 75°C case temperature, derate linearly at the rate of 333 mW/°C. To avoid exceeding the maximum virtual junction temperature, these ratings must not be exceeded.

recommended operating conditions

	MIN	NOM	MAX	UNIT
Supply voltage, V_{CC}	4.75	5	5.25	V
High-level input voltage, V_{IH}	0.7 V_{CC}		5.25	V
Low-level input voltage, V_{IL}	–0.3		0.2 V_{CC}	V
Output voltage, $V_{O(off)}$			30	V
Continuous output current, $I_{O(on)}$			1	A
Operating case temperature, T_C	–40	25	105	°C



TPIC2801

OCTAL INTELLIGENT-POWER SWITCH WITH SERIAL INPUT

SLIS008 – D3282, AUGUST 1989 – REVISED JUNE 1990

electrical characteristics over recommended ranges of supply voltage and operating case temperature (unless otherwise noted)

driver array outputs (Y0 to Y7)

PARAMETER		TEST CONDITIONS	MIN	TYP†	MAX	UNIT	
V_{OK}	Output clamp voltage	$I_O = 0.5$ A, Output programmed off and current shunted to GND	30	36	40	V	
$V_{O(on)}$	On-state output voltage	With output programmed on	$I_{OL} = 0.5$ A		0.4	0.5	V
			$I_{OL} = 0.75$ A		0.6	1	V
			$I_{OL} = 1$ A, During unlatch disable		0.8	1.5	V
V_{TOS}	Out-of-saturation threshold voltage	With output programmed on and an overcurrent fault condition	1.6	1.8	2	V	
$I_{O(off)}$	Off-state output current	$V_O = 24$ V with output programmed off			1	mA	
$I_{O(cl)}$	Output current limit	$V_O = 3$ V with output programmed on	1.05	1.4		A	

shift register (inputs SI, \overline{SIOE} , SCLK, and RST)

PARAMETER		TEST CONDITIONS	MIN	MAX	UNIT
V_{T+}	Positive-going threshold voltage			$0.7 V_{CC}$	V
V_{T-}	Negative-going threshold voltage		$0.2 V_{CC}$		V
V_{hys}	Hysteresis voltage ($V_{T+} - V_{T-}$)		0.85	2.25	V
I_I	Input current	$V_I = 0$ to V_{CC}		± 10	μ A
C_i	Input capacitance	$V_I = 0$ to V_{CC}		20	pF

shift register (output SO)

PARAMETER		TEST CONDITIONS	MIN	TYP†	MAX	UNIT
V_{OL}	Low-level output voltage	$I_O = 1.6$ mA		0.2	0.4	V
V_{OH}	High-level output voltage	$I_O = -0.8$ mA	$V_{CC} - 1.3$			V
I_O	Output current	$V_O = 0$ to V_{CC} , \overline{SIOE} input high			± 10	μ A
I_{CC}	Supply current	All outputs on, $I_O = 0.5$ A at all outputs	$T_J = 105^\circ\text{C}$		150	mA
			$T_J = 25^\circ\text{C}$		200	
			$T_J = -40^\circ\text{C}$		250	
		All outputs off	$T_J = 25^\circ\text{C}$	4	10	
C_O	Output capacitance	$V_O = 0$ to V_{CC} , \overline{SIOE} input high			20	pF

† All typical values are at $V_{CC} = 5$ V, $T_J = 25^\circ\text{C}$.



TPIC2801
OCTAL INTELLIGENT-POWER SWITCH
WITH SERIAL INPUT

SLIS008 – D3282, AUGUST 1989 – REVISED JUNE 1990

timing requirements over recommended ranges of supply voltage and operating case temperature (see Figure 1)

		MIN	MAX	UNIT
f_{clock}	Clock frequency, SCLK	0	500	kHz
$t_{\text{w}}(\text{SCLKH})$	Pulse duration, SCLK high	See Note 5		840
$t_{\text{w}}(\text{SCLKL})$	Pulse duration, SCLK low			840
$t_{\text{w}}(\text{RST})$	Pulse duration, $\overline{\text{RST}}$ low			1000
t_{su1}	Setup time, $\overline{\text{SIOE}}\downarrow$ before SCLK \uparrow	1000		ns
t_{su2}	Setup time, SCLK \downarrow before $\overline{\text{SIOE}}\uparrow$	1000		ns
t_{su3}	Setup time, SI high before SCLK \downarrow	500		ns
t_{h1}	Hold time, SI low after SCLK \downarrow	500		ns
t_{r}	Rise time (SCLK, SI, $\overline{\text{SIOE}}$)		2	μs
t_{f}	Fall time (SCLK, SI, $\overline{\text{SIOE}}$)		2	μs

NOTE 5: For cascaded operation, the clock pulse durations [$t_{\text{w}}(\text{SCLKL})$ and $t_{\text{w}}(\text{SCLKH})$] must be a minimum of 700 ns (giving a maximum clock frequency of 632 kHz).

thermal characteristics

PARAMETER		MIN	MAX	UNIT
$R_{\theta\text{JC}}$	Thermal resistance, junction-to-case temperature		3	$^{\circ}\text{C}/\text{W}$
$R_{\theta\text{JA}}$	Thermal resistance, junction-to-ambient temperature		35	$^{\circ}\text{C}/\text{W}$

switching characteristics over recommended ranges of supply voltage and operating case temperature

PARAMETER	FROM (INPUT)	TO (OUTPUT)	TEST CONDITIONS	MIN	MAX	UNIT	
t_{en}	Enable time	$\overline{\text{SIOE}}\downarrow$	SO	$C_{\text{L}} = 20 \text{ pF}$, $R_{\text{L}} = 2 \text{ k}\Omega$, See Figure 2	1000	ns	
t_{dis}	Disable time	$\overline{\text{SIOE}}\uparrow$	SO	$C_{\text{L}} = 20 \text{ pF}$, $R_{\text{L}} = 2 \text{ k}\Omega$, See Figure 2	1000	ns	
t_{d1}	Delay time, valid data	SCLK \uparrow	SO	$C_{\text{L}} = 200 \text{ pF}$, See Figure 3	740	ns	
t_{d2}	Delay time, unlatch disable	$\overline{\text{SIOE}}\uparrow$	Y_{n}	$C_{\text{L}} = 20 \text{ pF}$, $R_{\text{L}} = 5 \Omega$, See Figure 4	75	250	μs
$t_{\text{r}}(\text{SO})$	Rise time, SO			$C_{\text{L}} = 200 \text{ pF}$, See Figure 3	150	ns	
$t_{\text{f}}(\text{SO})$	Fall time, SO			$C_{\text{L}} = 200 \text{ pF}$, See Figure 3	150	ns	
$t_{\text{d}}(\text{on})$	Delay time, turn on	$\overline{\text{SIOE}}\uparrow$	Y_{n}	$C_{\text{L}} = 20 \text{ pF}$, $R_{\text{L}} = 28 \Omega$, $I_{\text{OL}} = 500 \text{ mA}$, See Figure 5	10	μs	
$t_{\text{d}}(\text{off})$	Delay time, turn off	$\overline{\text{SIOE}}\uparrow$	Y_{n}	$C_{\text{L}} = 20 \text{ pF}$, $R_{\text{L}} = 28 \Omega$, $I_{\text{OL}} = 500 \text{ mA}$, See Figure 5	10	μs	
t_{v}	Valid time, SO output data remains valid after SCLK high	SCLK \uparrow	SO	$C_{\text{L}} = 200 \text{ pF}$, See Figure 3	0	ns	



TPIC2801 OCTAL INTELLIGENT-POWER SWITCH WITH SERIAL INPUT

SLIS008 – D3282, AUGUST 1989 – REVISED JUNE 1990

PARAMETER MEASUREMENT INFORMATION

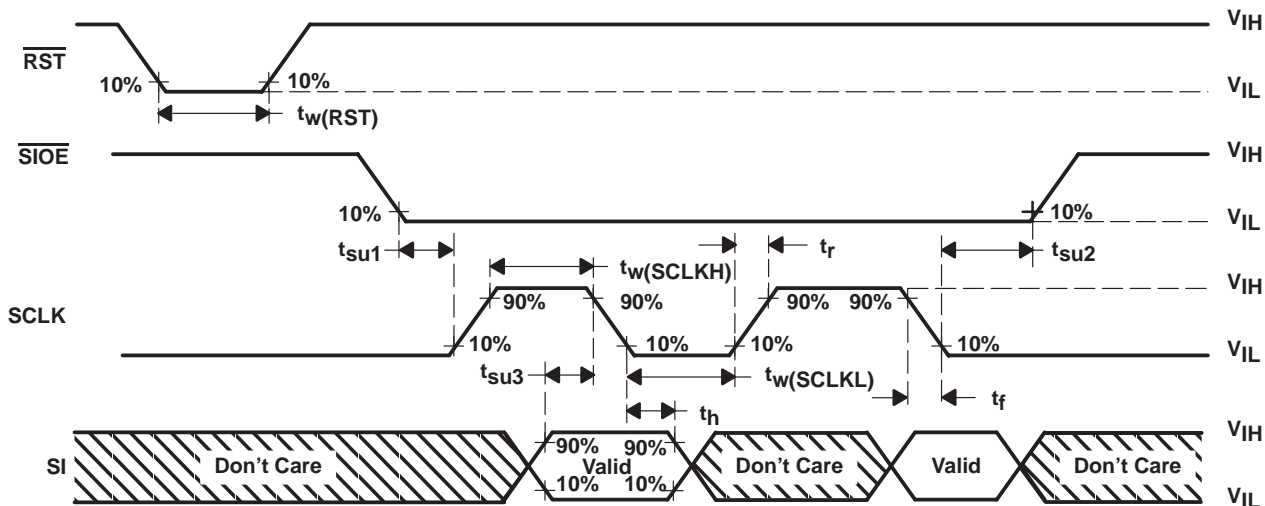
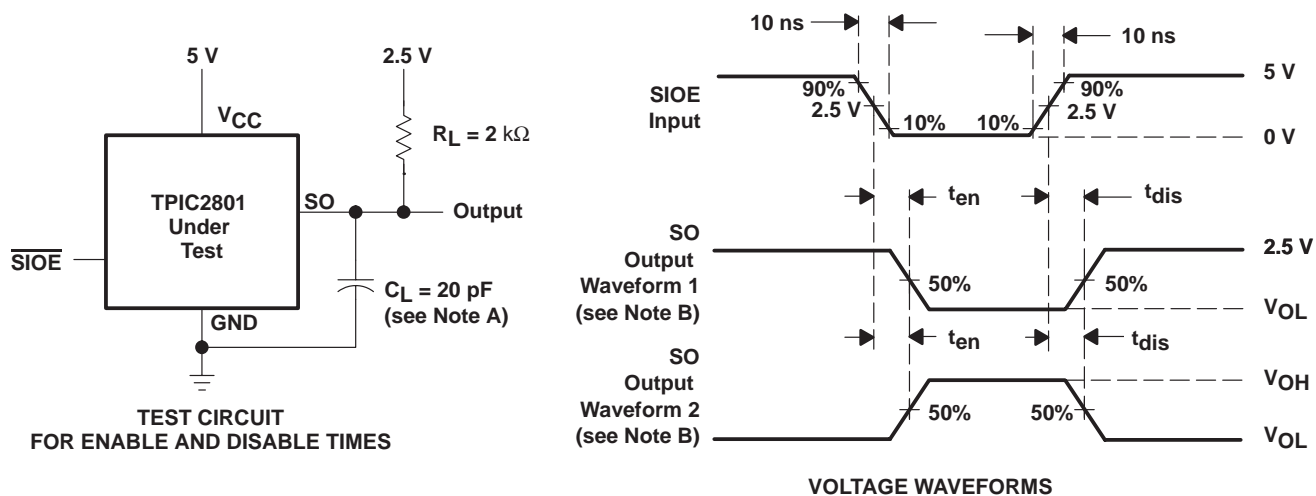

Figure 1. Input Timing Waveforms



NOTES: A. C_L includes probe and jig capacitance.

B. Waveform 1 is for an output with internal conditions such that the output is low except when disabled by the output control when $\overline{\text{SIOE}}$ is high. Waveform 2 is for an output with internal conditions such that the output is high except when disabled by the output control when $\overline{\text{SIOE}}$ is high.

Figure 2. Test Circuit and Voltage Waveforms for Enable and Disable Times

PARAMETER MEASUREMENT INFORMATION

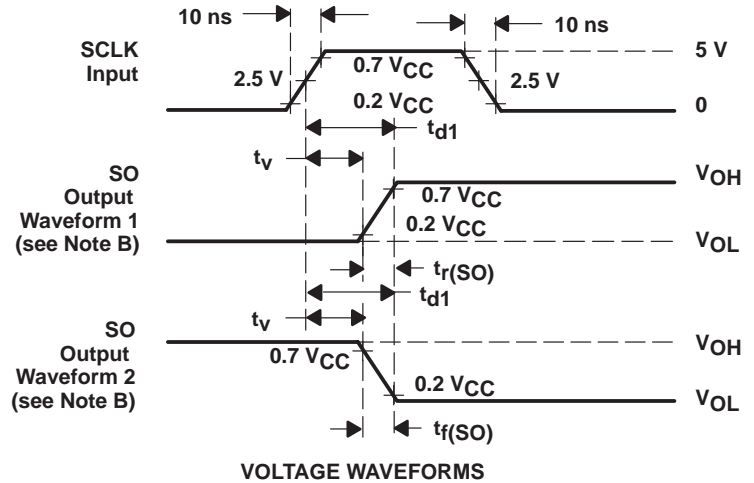
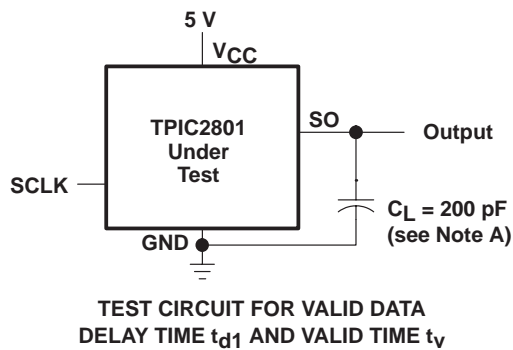

NOTES: A. C_L includes probe and jig capacitance.

B. Waveform 1 is for an output with internal conditions such that the low-to-high transition of SCLK causes the SO output to switch from low to high. Waveform 2 is for an output with internal conditions such that the low-to-high transition of SCLK causes the SO output to switch from high to low.

Figure 3. Test Circuit and Voltage Waveforms for Delay Times

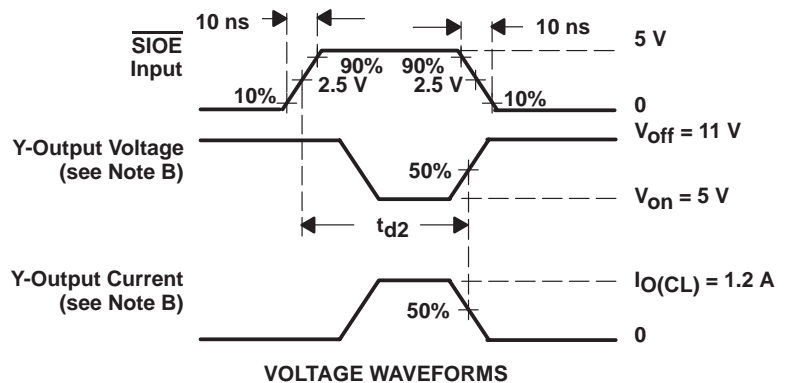
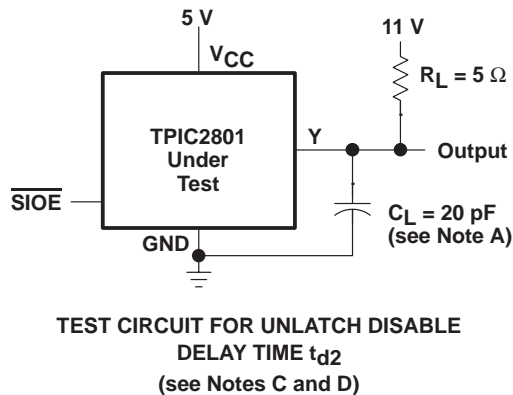

NOTES: A. C_L includes probe and jig capacitance.

B. Output voltage and current waveforms are for an output with internal conditions such that the low-to-high transition of $\overline{\text{SIOE}}$ causes the output to switch from being off to being on.

C. t_{d2} = delay until Y-output current goes off under fault condition.

D. Load voltage V_S and load resistance R_L are selected such that on-state voltage at the Y output under test, V_{On} is greater than the maximum out-of-saturation hold voltage, V_{TOS} . Thus $V_{OL} = V_{On} > V_{TOS(max)} = 1.98 \text{ V}$.

Figure 4. Test Circuit and Voltage and Current Waveforms for Unlatch Disable Delay

TPIC2801 OCTAL INTELLIGENT-POWER SWITCH WITH SERIAL INPUT

SLIS008 – D3282, AUGUST 1989 – REVISED JUNE 1990

PARAMETER MEASUREMENT INFORMATION

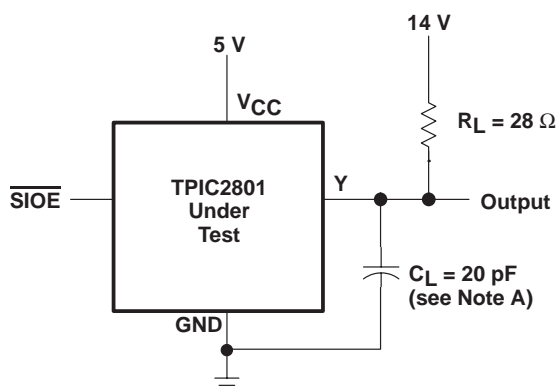

TEST CIRCUIT FOR TURN-OFF $t_{d(off)}$ AND
TURN-ON $t_{d(on)}$ DELAY TIMES
(see Note C)

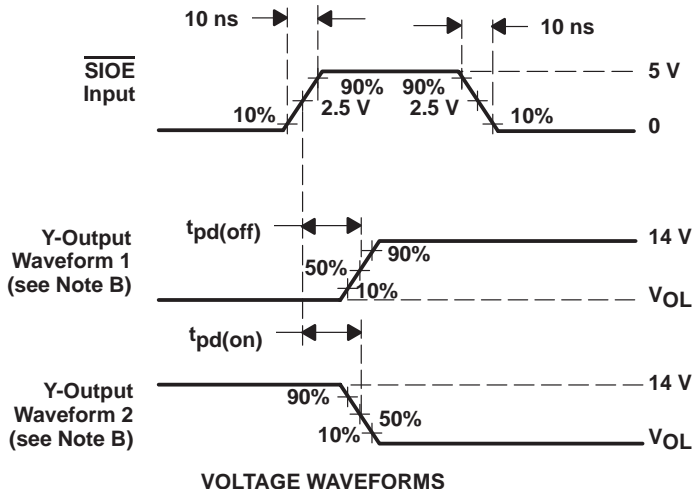

NOTES: A. C_L includes probe and jig capacitance.

B. Waveform 1 is for an output with internal conditions such that the low-to-high transition of \overline{SIOE} causes the output to switch from on to off. Waveform 2 is for an output with internal conditions such that the low-to-high transition of \overline{SIOE} causes the output to switch from off to on.

C. $t_{d(off)} = t_{PLH}$, $t_{d(on)} = t_{PHL}$.

Figure 5. Test Circuit and Voltage Waveforms for Turn-Off and Turn-On Delay Times

APPLICATION INFORMATION

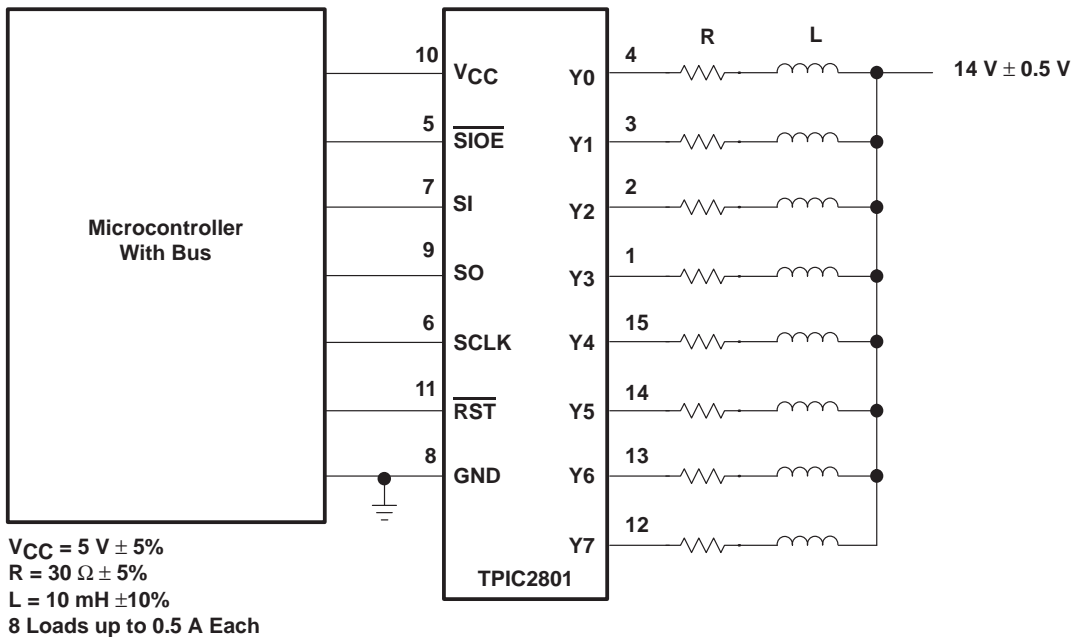

Figure 6. Microcontroller Driving Eight Loads Using a TPIC2801 for Load Interface

PRINCIPLES OF OPERATION

timing data transfer

Figure 7 shows the overall 8-bit data-byte transfer to and from the TPIC2801 interface bus. The logic state of the eight output drivers, Y0 through Y7, is latched into the shift register at time t_0 on the high-to-low transition of $\overline{\text{SIOE}}$. Therefore, the SO output data (DY0, DY1 . . .) represent the conditions at the Y-driver outputs at time t_0 . The data at the SO output is updated on the low-to-high transition of SCLK.

Input data present at the SI input is clocked into the shift register on the high-to-low transition of SCLK. As shown in Figure 6 on the SI input, input data DI7 is clocked at time t_1 , DI6 is clocked at time t_2 , etc. Eight SCLK pulses are used to serially load the eight bits of new data into the device. After all the new data is serially loaded, the low-to-high transition of $\overline{\text{SIOE}}$ parallel loads the new data to the eight driver output latches, which in turn directly control the eight Y-driver outputs.

An unlimited amount of data can be shifted through the shift register (into the SI and out the SO), and this allows other devices to be cascaded in a daisy chain with the TPIC2801. Once the last data bit is shifted into the TPIC2801, the $\overline{\text{SIOE}}$ input is pulled high. The clock (SCLK) input is low at both transitions of the $\overline{\text{SIOE}}$ input to avoid any false clocking of the shift register. The SCLK input is gated by the $\overline{\text{SIOE}}$ input, so the SCLK input is ignored whenever $\overline{\text{SIOE}}$ is high. At the rising edge of $\overline{\text{SIOE}}$, the shift register data is latched into the parallel latch and the output stages are actuated by the new data. An internal 100- μs delay timer is also started on this rising edge. During the time delay, the outputs are protected only by the analog current-limiting circuits, since the resetting of the parallel latches by fault conditions are inhibited during this time period. This allows the device to overcome any high switching currents that can flow during turn on. Once the delay ends, the output voltages are sensed by the comparators and any output voltages higher than nominally 1.8 V are latched off.

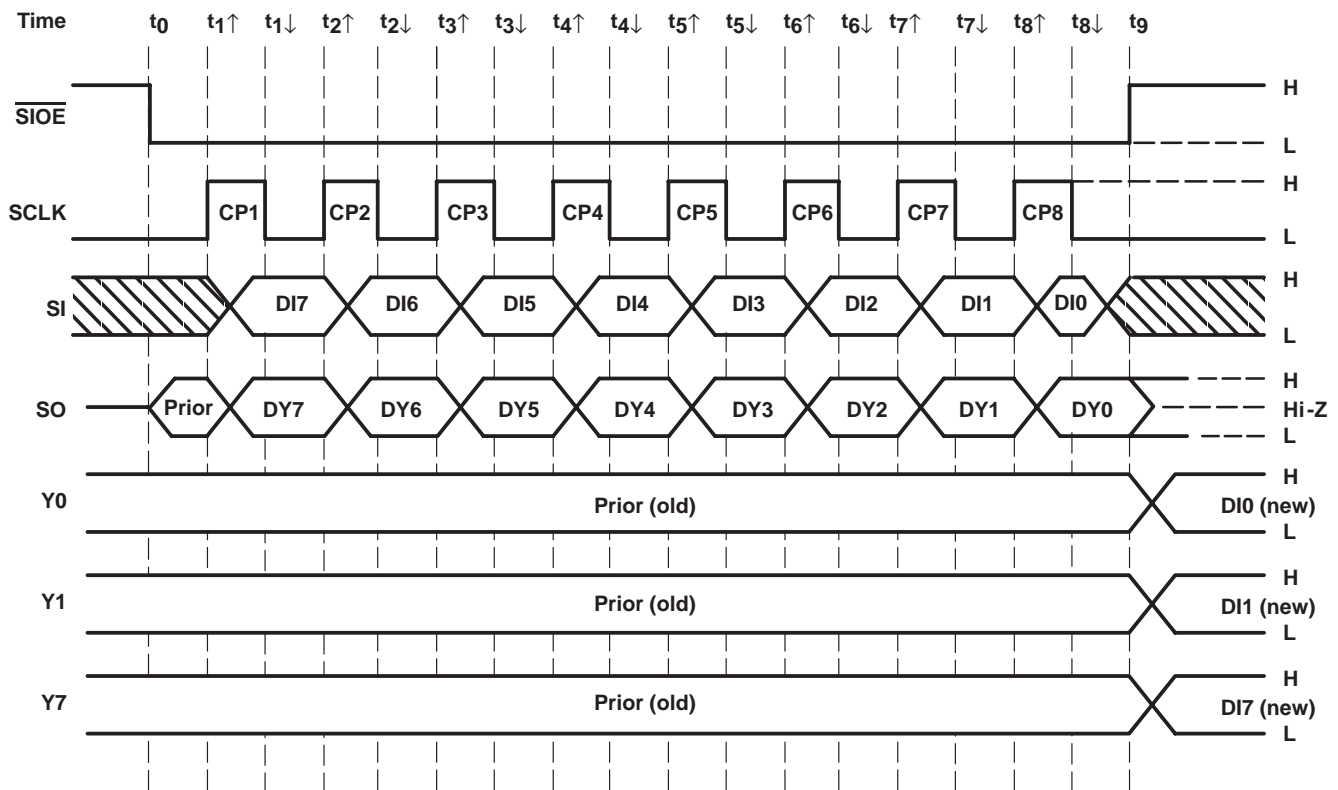

Figure 7. Data-Byte Transfer Timing

TPIC2801 OCTAL INTELLIGENT-POWER SWITCH WITH SERIAL INPUT

SLIS008 – D3282, AUGUST 1989 – REVISED JUNE 1990

PRINCIPLES OF OPERATION

fault-conditions check

Open-circuit conditions on any output can be monitored or checked by programming that output off. After a short delay (microseconds), another control byte can be clocked into the device. If the diagnostic bit for that output comes back as a low, it indicates that the output is low and open circuited. A current overload condition can be detected by programming an output on. After waiting an appropriate length of time, another byte is clocked into the TPIC2801. The diagnostic bit clocked back from the TPIC2801 in the subsequent data transfer indicates a low output. If a high returns, a current overload is indicated. A quick overall check is done by clocking in a test control byte. After a sufficient time delay, clock in another control byte (same byte is used). The diagnostic data is exclusive ORed with the original control byte. If a fault condition exists, a high results from the subsequent exclusive OR.

IMPORTANT NOTICE

Texas Instruments Incorporated and its subsidiaries (TI) reserve the right to make corrections, modifications, enhancements, improvements, and other changes to its products and services at any time and to discontinue any product or service without notice. Customers should obtain the latest relevant information before placing orders and should verify that such information is current and complete. All products are sold subject to TI's terms and conditions of sale supplied at the time of order acknowledgment.

TI warrants performance of its hardware products to the specifications applicable at the time of sale in accordance with TI's standard warranty. Testing and other quality control techniques are used to the extent TI deems necessary to support this warranty. Except where mandated by government requirements, testing of all parameters of each product is not necessarily performed.

TI assumes no liability for applications assistance or customer product design. Customers are responsible for their products and applications using TI components. To minimize the risks associated with customer products and applications, customers should provide adequate design and operating safeguards.

TI does not warrant or represent that any license, either express or implied, is granted under any TI patent right, copyright, mask work right, or other TI intellectual property right relating to any combination, machine, or process in which TI products or services are used. Information published by TI regarding third-party products or services does not constitute a license from TI to use such products or services or a warranty or endorsement thereof. Use of such information may require a license from a third party under the patents or other intellectual property of the third party, or a license from TI under the patents or other intellectual property of TI.

Reproduction of TI information in TI data books or data sheets is permissible only if reproduction is without alteration and is accompanied by all associated warranties, conditions, limitations, and notices. Reproduction of this information with alteration is an unfair and deceptive business practice. TI is not responsible or liable for such altered documentation. Information of third parties may be subject to additional restrictions.

Resale of TI products or services with statements different from or beyond the parameters stated by TI for that product or service voids all express and any implied warranties for the associated TI product or service and is an unfair and deceptive business practice. TI is not responsible or liable for any such statements.

TI products are not authorized for use in safety-critical applications (such as life support) where a failure of the TI product would reasonably be expected to cause severe personal injury or death, unless officers of the parties have executed an agreement specifically governing such use. Buyers represent that they have all necessary expertise in the safety and regulatory ramifications of their applications, and acknowledge and agree that they are solely responsible for all legal, regulatory and safety-related requirements concerning their products and any use of TI products in such safety-critical applications, notwithstanding any applications-related information or support that may be provided by TI. Further, Buyers must fully indemnify TI and its representatives against any damages arising out of the use of TI products in such safety-critical applications.

TI products are neither designed nor intended for use in military/aerospace applications or environments unless the TI products are specifically designated by TI as military-grade or "enhanced plastic." Only products designated by TI as military-grade meet military specifications. Buyers acknowledge and agree that any such use of TI products which TI has not designated as military-grade is solely at the Buyer's risk, and that they are solely responsible for compliance with all legal and regulatory requirements in connection with such use.

TI products are neither designed nor intended for use in automotive applications or environments unless the specific TI products are designated by TI as compliant with ISO/TS 16949 requirements. Buyers acknowledge and agree that, if they use any non-designated products in automotive applications, TI will not be responsible for any failure to meet such requirements.

Following are URLs where you can obtain information on other Texas Instruments products and application solutions:

Products

Amplifiers	amplifier.ti.com
Data Converters	dataconverter.ti.com
DSP	dsp.ti.com
Clocks and Timers	www.ti.com/clocks
Interface	interface.ti.com
Logic	logic.ti.com
Power Mgmt	power.ti.com
Microcontrollers	microcontroller.ti.com
RFID	www.ti-rfid.com
RF/IF and ZigBee® Solutions	www.ti.com/lprf

Applications

Audio	www.ti.com/audio
Automotive	www.ti.com/automotive
Broadband	www.ti.com/broadband
Digital Control	www.ti.com/digitalcontrol
Medical	www.ti.com/medical
Military	www.ti.com/military
Optical Networking	www.ti.com/opticalnetwork
Security	www.ti.com/security
Telephony	www.ti.com/telephony
Video & Imaging	www.ti.com/video
Wireless	www.ti.com/wireless

Mailing Address: Texas Instruments, Post Office Box 655303, Dallas, Texas 75265
Copyright © 2008, Texas Instruments Incorporated