

Thermopile Sensor

TPS 232 / 3214

Revision - Date: 2007/11/12

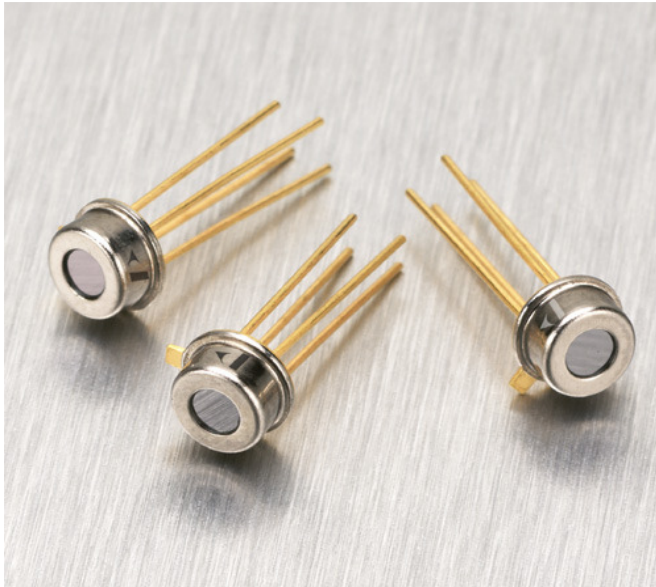

Introduction

PerkinElmer introduces the new TPS 232 as part of the TPS 23x family for low-cost remote temperature measurement applications. It consists of a silicon (Si) based thermopile chip in a metal housing with IR transmissive filter. The Si-chip carries a series of thermoelements, forming a sensitive area covered by an IR absorbing material.

With its optimized output signal, the TPS 23x family replaces the TPS 43x series by offering better performance at a lower cost.

The thermopile sensing principle allows for broadband IR measurements. PerkinElmer Optoelectronics thermopile sensors are equipped with a MEMS / MOEMS state-of-the art sensing element and an optical filter that defines the sensitive spectral range of the sensor and at the same time serves as device window.

Properties of TPS 232

The TPS 232 is a small thermopile sensor TO-46 (4.7 mm cap diameter) housing. It is especially suited for ear thermometer solutions. The sensor employs a very small thermopile chip with a 0.5 mm round active area allowing small spot sizes in pyrometer applications. The chip is optimized for a large output signal.

The round window is equipped with a PerkinElmer's standard IR longpass filter with 5.5 μm cut-on wavelength. The frequency behavior corresponds to a low pass characteristic.

A 100 k Ω thermistor inside the TO-housing serves as the ambient temperature reference.

Features and Benefits

- Miniature TO-46 housing (4.7 mm \varnothing)
- Small and perfectly round measurement spot
- Large output voltage
- Large field of view of 115°
- High signal to noise ratio
- 5.5 μm IR longpass filter
- Stable signal in the case of ambient thermal shock due to the small TO-46 housing
- RoHS compliant – Si-chip made by standard CMOS processes

Applications

- High precision temperature sensing
- Ear thermometer
- Infrared pyrometry

Table of Contents

1	General Characteristics	3
1.1	Absolute Maximum Ratings	3
1.2	Handling Requirements	3
2	Type Characteristics	3
2.1	Design Characteristics	3
2.2	Electrical Characteristics	3
2.3	Optical Characteristics	6
2.4	Mechanical Drawing	7
3	Quality Statement.....	7
3.1	Liability Policy	7

List of Figures

Figure 1:	Typical output voltage versus object temperature with sensor at 25 ° C.....	4
Figure 2:	Field of View Curve.....	6
Figure 3:	Transmission Curve for PerkinElmer Standard Filter	6
Figure 4:	Mechanical Drawing of the TPS 232	7

List of Tables

Table 1:	Absolute Maximum Ratings	3
Table 2:	Design Characteristics	3
Table 3:	Thermopile sensor characteristics	3
Table 4:	Typical numerical data of Thermopile's output voltage (sensor at 25 ° C).....	4
Table 5:	Thermistor 100 kΩ	5
Table 6:	Tabulated Thermistor Data	5
Table 7:	Optical Characteristics	6
Table 8:	Filter Parameters	6

1 General Characteristics

1.1 Absolute Maximum Ratings

Table 1: Absolute Maximum Ratings

Symbol	Parameter	Min	Typ	Max	Unit	Conditions
T _A	Ambient temperature range	-20		100	°C	Operation
T _A	Ambient temperature range	-40		100	°C	Storage

1.2 Handling Requirements

Stresses above the absolute maximum ratings may cause damages to the device. Do not expose the sensor to aggressive detergents such as Freon, Trichloroethylene, etc. Windows may be cleaned with alcohol and cotton swab. Hand soldering and wave soldering may be applied by a maximum temperature of 260 °C for a dwell time less than 10 s. Avoid heat exposure to the top and the window of the detector. Reflow soldering is not recommended.

2 Type Characteristics

2.1 Design Characteristics

The Sensor TPS 232 is a lead-free component and fully complies with the RoHS regulations.

Table 2: Design Characteristics

Parameter	Description
Cap	Metal cap with integrated IR window
Header	TO-46
Leads	(3 isolated + 1 ground) pins with solderable gold coating
Filter type	Si-based interference IR longpass filter
Temperature reference	Thermistor 100 kΩ
Insulation gas sealing	The sensor is sealed in a dry nitrogen environment and gross leak proof
Device marking	PerkinElmer Logo "P" + device number xxxx + 3 digits date code YWW

2.2 Electrical Characteristics

Table 3: Thermopile sensor characteristics

Symbol	Parameter	Min	Typ	Max	Unit	Conditions
	Sensitive area		0.2		mm ²	Absorber area
R _{TP}	Resistance	80		135	kΩ	
S _V	Responsivity		42		V/W	T _{obj} = 500 K (=227 °C), T _{amb} = 298 K (=25 °C) 1Hz,
ΔU / ΔT	Average sensitivity		42		μV/K	T _{obj} = 313 K (=40 °C), T _{amb} = 298 K (=25 °C)
ΔU / ΔT	Average sensitivity		56		μV/K	T _{obj} = 373 K (=100 °C), T _{amb} = 298 K (=25 °C)
τ	Time constant		15		ms	
V _{RMS}	Noise voltage		40		nV/√Hz	
	TC of resistance		0.03		%/K	
	TC of sensitivity		-0.05		%/K	

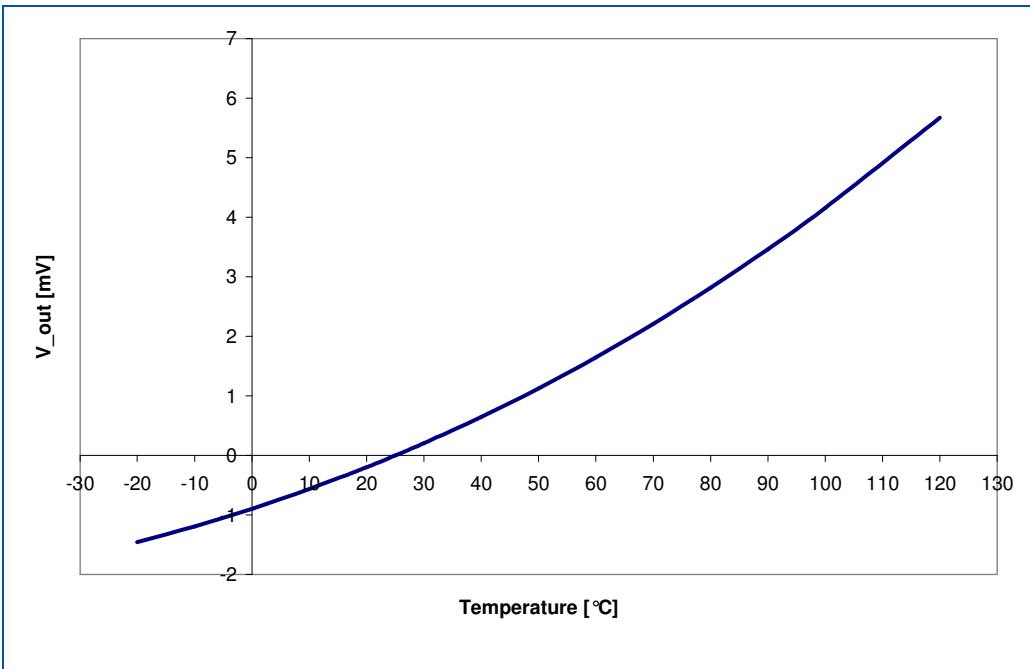

Figure 1: Typical output voltage versus object temperature with sensor at 25 °C.

Table 4: Typical numerical data of Thermopile’s output voltage (sensor at 25 °C)

Object Temp. °C	V _{out} mV
-20	-1.45
-10	-1.19
0	-0.89
10	-0.56
20	-0.20
25	0.00
30	0.21
40	0.65
50	1.13
60	1.65
70	2.21
80	2.82
90	3.46
100	4.16
120	5.67

Table 5: Thermistor 100 kΩ

Symbol	Parameter	Min	Typ	Max	Unit	Conditions
R25	Base resistance	95	100	105	kΩ	T _{amb} = 25 °C
β	BETA -value		3964		K	Defined at 25 °C/100 °C
β	BETA - tolerance			± 0.3	%	

Table 6: Tabulated Thermistor Data

Temp.	R _{min1}	R _{min2}	R _{nom}	R _{max2}	R _{max1}
°C	Ω	Ω	Ω	Ω	Ω
-20	862756	909418	915479	921581	968201
-15	655207	690548	694575	698625	733944
-10	501697	528693	531349	534018	561001
-5	387196	407985	409715	411452	432234
0	301098	317232	318336	319444	335574
5	235852	248468	249149	249832	262445
10	186038	195972	196369	196767	206701
15	147731	155608	155815	156022	163900
20	118070	124357	124439	124521	130808
25	95000	100000	100000	100000	105000
30	76707	80791	80843	80895	84978
35	62328	65649	65732	65815	69137
40	50926	53643	53743	53843	56559
45	41833	44067	44175	44283	46516
50	34541	36387	36497	36608	38453
55	28662	30195	30303	30412	31944
60	23898	25176	25280	25385	26663
65	20017	21089	21187	21286	22357
70	16842	17744	17836	17928	18830
75	14231	14994	15079	15165	15927
80	12075	12721	12800	12879	13526
85	10286	10838	10910	10983	11534
90	8796	9268	9334	9401	9872
95	7550	7956	8016	8077	8481
100	6504	6853	6908	6964	7313

- R_{min1} : Minimum Thermistor Resistance resulting from the Total Tolerance
- R_{min2} : Minimum Thermistor Resistance resulting from the BETA-Tolerance
- R_{nom} : Typical Thermistor Resistance
- R_{max1} : Maximum Thermistor Resistance resulting from the Total Tolerance
- R_{max2} : Maximum Thermistor Resistance resulting from the BETA-Tolerance

2.3 Optical Characteristics

Table 7: Optical Characteristics

Symbol	Parameter	Min	Typ	Max	Unit	Conditions
	Field of view		120		degree	At 50% target signal
	Optical axis		0	+/- 10	degree	

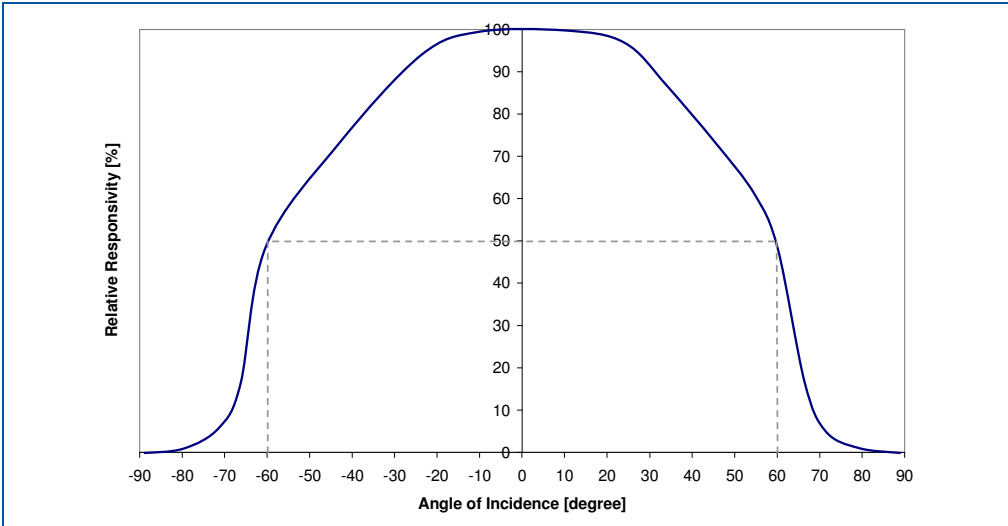

Figure 2:Field of View Curve

Table 8: Filter Parameters

Symbol	Parameter	Min	Typ	Max	Unit	Conditions
TA	Average transmittance	75	> 77		%	Wavelength range from 7.5 μm to 13.5 μm
TA	Average transmittance			< 0.5	%	Wavelength range < 5 μm
λ (5 %)	Cut on wavelength	5.2	5.5	5.8	μm	At 25° C

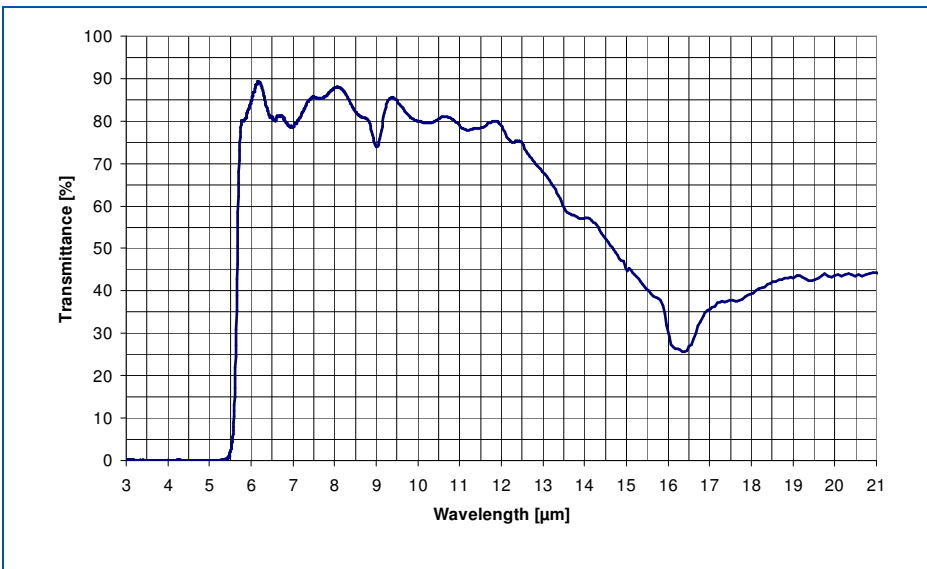

Figure 3:Transmission Curve for PerkinElmer Standard Filter

2.4 Mechanical Drawing

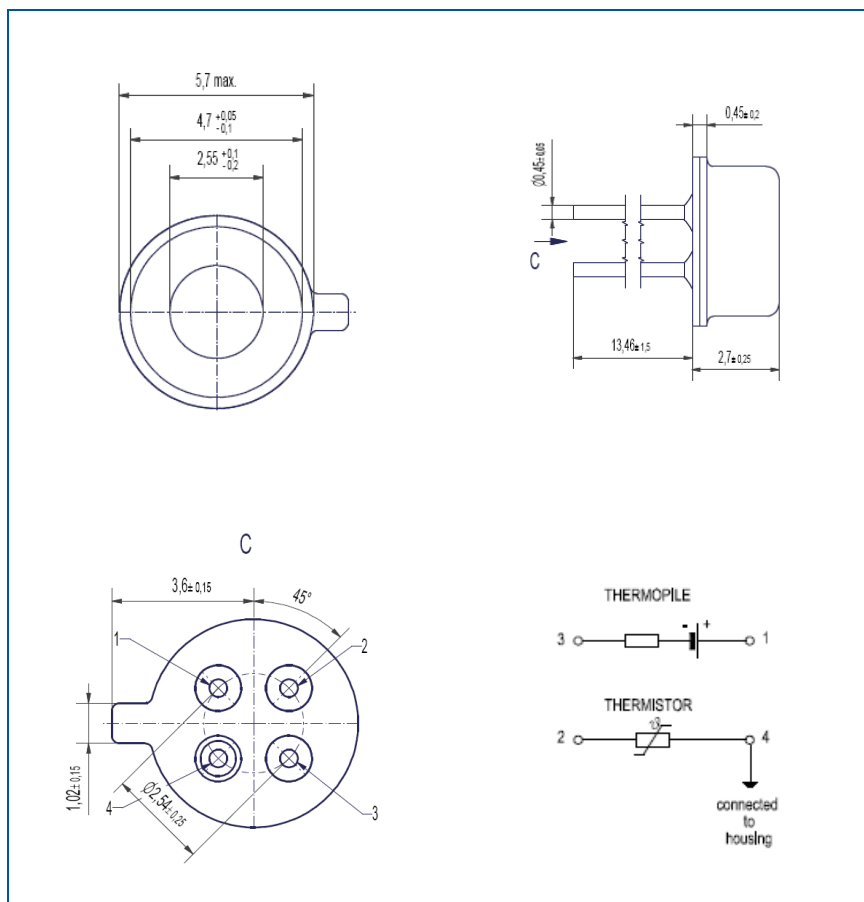

Figure 4: Mechanical Drawing of the TPS 232

3 Quality Statement

PerkinElmer Optoelectronics is an ISO 9001:2002 and ISO/TS 16949:2002 certified manufacturer. All devices employing PCB assemblies are manufactured according to IPC-A-610 guidelines.

3.1 Liability Policy

The contents of this document are subject to change without notice and customers should consult with PerkinElmer Optoelectronics sales representative before ordering. Customers considering the use of PerkinElmer Optoelectronics thermopile devices in applications where failure may cause personal injury or property damage, or where extremely high levels of reliability are demanded, are requested to discuss their concerns with PerkinElmer Optoelectronics sales representatives before such use. The Company's responsibility for damages will be limited to the repair or replacement of defective product. As with any semiconductor device, thermopile sensors or modules have a certain inherent rate of failure. To protect against injury, damage or loss from such failures, customers are advised to incorporate appropriate safety design measures into their product.

North America Customer Support Hub
PerkinElmer Optoelectronics
 22001 Dumberry Road
 Vaudreuil-Dorion, Québec
 Canada J7V 8P7
 Telephone: +1 450-424-3300, (+1) 866-574-6786 (toll-free)
 Fax: +1 450-424-3345
 Email: opto@perkinelmer.com
www.optoelectronics.perkinelmer.com

European Headquarters
PerkinElmer Optoelectronics
 Wenzel-Jaksch-Str. 31
 65199 Wiesbaden, Germany
 Telephone: (+49) 611-492-247
 Fax: (+49) 611-492-170
 Email: opto.Europe@perkinelmer.com

Asia Headquarters
PerkinElmer Optoelectronics
 47 Ayer Rajah Crescent #06-12
 Singapore 139947
 Telephone: (+65) 6775-2022
 Fax: (+65) 6775-1008
 Email: opto.Asia@perkinelmer.com



For a complete listing of our global offices, visit www.optoelectronics.perkinelmer.com

©2007 PerkinElmer, Inc. All rights reserved. The PerkinElmer logo and design are registered trademarks of PerkinElmer, Inc. All other trademarks not owned by PerkinElmer, Inc. or its subsidiaries that are depicted herein are the property of their respective owners. PerkinElmer reserves the right to change this document at any time without notice and disclaims liability for editorial, pictorial or typographical errors.
 600236_01 DTS1107