



## PC POWER-SUPPLY SUPERVISORS

### FEATURES

- Over-Voltage Protection and Lockout: 12V, 5V, and 3.3V Supplies
- Over-Current Protection and Lockout: 12V, 5V, and 3.3V Supplies
- Under-Voltage Protection and Lockout: 12V Supplies
- Under-Voltage Detect: 5V and 3.3V Supplies
- Fault-Protection Output with Open-Drain Output Stage
- Open-Drain, Power-Good Output Signal: Monitors Power-Good Signal Input 3.3V and 5V Supplies
- 300ms Power-Good Delay
- 75ms Delay: 5V, 3.3V Power-Supply Short-Circuit Turn-On Protection
- 2.3ms  $\overline{\text{PSON}}$  Control To  $\overline{\text{FPO}}$  Turn-Off Delay
- 38ms  $\overline{\text{PSON}}$  Control Debounce
- Wide Supply Voltage Range: 4.5V to 15V

### DESCRIPTION

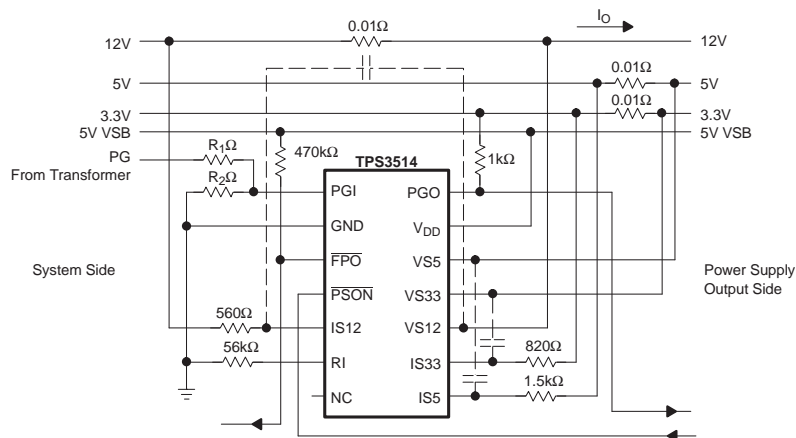
The TPS3514 is a PC switching power-supply system monitor with minimum external components. It provides under-voltage lockout (UVLO), over-voltage (OV), under-voltage (UV), over-current (OC) protection circuits, power-good indicator, and on/off control.

UVLO thresholds are 4.45V (on) and 3.65V (off). Over-current protection (OCP) and over-voltage protection (OVP) monitor 3.3V, 5V, and 12V supplies. When an OC or OV condition is detected, the power-good output (PGO) is asserted low and the fault protection output ( $\overline{\text{FPO}}$ ) is latched high.  $\overline{\text{PSON}}$  from low-to-high resets the latch. The OCP function will be enabled 75ms after  $\overline{\text{PSON}}$  goes LOW with PGI HIGH and a debounce of typically 38ms. A built-in 2.3ms delay with 38ms debounce from  $\overline{\text{PSON}}$  to  $\overline{\text{FPO}}$  output is enabled at turn-off.

An external resistor is connected between the RI pin and the GND pin. This will program a precise  $I_{(\text{REF})}$  for OCP function. The programmable  $I_{(\text{REF})}$  range is from 12.5 $\mu\text{A}$  to 62.5 $\mu\text{A}$ . Three OCP comparators and the  $I_{(\text{REF})}$  section are supplied by VS12. The current draw from the VS12 pin is less than 1mA.

The power-good feature monitors PGI, the 3.3V and 5V supplies, and issues a power-good signal when the output is ready.

The TPS3514 is characterized for operation from  $-40^{\circ}\text{C}$  to  $+85^{\circ}\text{C}$ . The TPS3514 is available in DIP-14 and SO-14 packages.



Please be aware that an important notice concerning availability, standard warranty, and use in critical applications of Texas Instruments semiconductor products and disclaimers thereto appears at the end of this data sheet.

All trademarks are the property of their respective owners.



This integrated circuit can be damaged by ESD. Texas Instruments recommends that all integrated circuits be handled with appropriate precautions. Failure to observe proper handling and installation procedures can cause damage.

ESD damage can range from subtle performance degradation to complete device failure. Precision integrated circuits may be more susceptible to damage because very small parametric changes could cause the device not to meet its published specifications.

### PACKAGE/ORDERING INFORMATION

PRODUCT	PACKAGE-LEAD	PACKAGE DESIGNATOR <sup>(1)</sup>	SPECIFIED TEMPERATURE RANGE	PACKAGE MARKING	ORDERING NUMBER	TRANSPORT MEDIA, QUANTITY
TPS3514	SO-14	D	40°C to +85°C	TPS3514	TPS3514D	Rails, 50
	DIP-14	N			TPS3514DR	Tape and Reel, 2500
					TPS3514N	Rails, 25

(1) For the most current package and ordering information see the Package Option Addendum at the end of this document, or see the TI web site at [www.ti.com](http://www.ti.com).

### ABSOLUTE MAXIMUM RATINGS

over operating free-air temperature range (unless otherwise noted)<sup>(1)(2)</sup>

	UNIT
Supply Voltage, VDD	16V
Voltage on $\overline{\text{PSON}}$ , IS5, IS33, PGI	8V
Voltage on VS33, VS5	16V
Voltage on $\overline{\text{FPO}}$	16V
Voltage on PGO	8V
All Other Pins	-0.3V to 16V
Continuous Total Power Dissipation	See <a href="#">Dissipation Ratings Table</a>
Operating Free-Air Temperature Range, T <sub>A</sub>	-40°C to +85°C
Storage Temperature Range, T <sub>stg</sub>	-65°C to +150°C
Soldering Temperature	260°C

- (1) Stresses beyond those listed under *Absolute Maximum Ratings* may cause permanent damage to the device. These are stress ratings only, and functional operation of the device at these or any other conditions beyond those indicated under *Recommended Operating Conditions* is not implied. Exposure to absolute-maximum-rated conditions for extended periods may affect device reliability.
- (2) All voltage values are with respect to GND.

## RECOMMENDED OPERATING CONDITIONS

At specified temperature range.

PARAMETER		MIN	MAX	UNIT
Supply Voltage	$V_{DD}$	4.5	15	V
Inputs	$V_I$			
PS0N, VS5, VS33, IS5, IS33			7	V
VS12, IS12			15	V
PGI			$V_{DD} + 0.3V$ (max = 7V)	V
Outputs	$V_O$			
FPO			15	V
PGO			7	V
Sink Current	$I_{O(SINK)}$			
FPO			20	mA
PGO			10	mA
Supply Voltage Rising Time	$t_R^{(1)}$	1		ms
OCP Reference Source	$I_{(REF)}$	12.5	62.5	$\mu A$
Operating Free-Air Temperature Range	$T_A$	-40	+85	$^{\circ}C$

(1)  $V_{DD}$  rising and falling slew rate must be less than 14V/ms.

## DISSIPATION RATINGS TABLE

PACKAGE	$T_A \leq +25^{\circ}C$ POWER RATING	DERATING FACTOR ABOVE $T_A = +25^{\circ}C$	$T_A = +70^{\circ}C$ POWER RATING	$T_A = +85^{\circ}C$ POWER RATING
D	956mW	7.65mW/ $^{\circ}C$	612mW	497mW
N	1512mW	12.1mW/ $^{\circ}C$	968mW	786mW

## OVER-CURRENT PROTECTION

	MAX OUTPUT CURRENT	OVER-CURRENT PROTECTION TRIP POINT <sup>(1)</sup>
12V	6A	9.2A
5V	16A	24.6A
3.3V	9A	13.5A

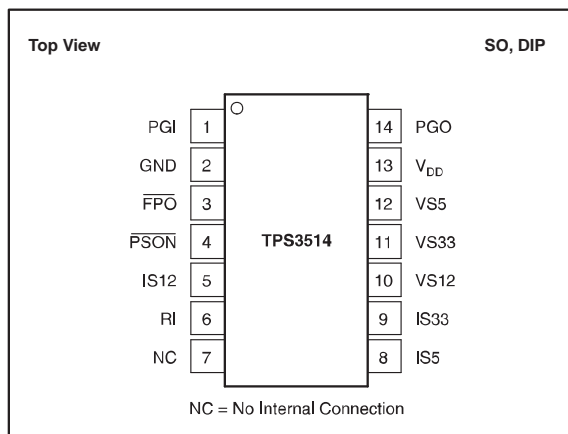
(1) Over-current protection trip point can be programmable.

**ELECTRICAL CHARACTERISTICS**

Limits apply over operating free-air temperature range,  $T_A = -40^{\circ}\text{C}$  to  $+85^{\circ}\text{C}$ , unless otherwise noted.

PARAMETER	CONDITIONS	TPS3514			UNIT
		MIN	TYP	MAX	
<b>OVER-VOLTAGE AND OVER-CURRENT PROTECTION</b>					
Over-Voltage Threshold					
VS33		3.7	3.9	4.1	V
VS5		5.7	6.1	6.5	V
VS12		13.2	13.8	14.4	V
Ratio of Current Sense Sink Current to Current Sense Setting Pin (RI) Source Current, $I_{(REF)}$	C	Resistor at $R_I = 30\text{k}\Omega$ , 0.1% Resistor		8.4	
Leakage Current ( $\overline{FPO}$ )	$I_{(kg)}$	$V_{(\overline{FPO})} = 5\text{V}$		5	$\mu\text{A}$
Low-Level Output Voltage ( $\overline{FPO}$ )	$V_{(OL)}$	$I_{(SINK)} = 20\text{mA}$ , $V_{DD} = 5\text{V}$		0.7	V
Noise Deglitch Time (OVP)		$V_{DD} = 5\text{V}$		110	$\mu\text{s}$
Current Source Reference Voltage	$V_{(RI)}$	$V_{DD} = 5\text{V}$		1.2	V
<b>UNDER-VOLTAGE LOCKOUT</b>					
Start Threshold Voltage				4.45	V
Minimum Operating Voltage After Start-Up		3.65			V
<b>PGI AND PGO</b>					
Input Threshold	$V_{IT(PGI)}$	0.9 x typ	1.15	1.01 x typ	V
Under-Voltage Threshold					
VS33		2	2.2	2.4	V
VS5		3.3	3.5	3.7	V
VS12		8.5	9	9.5	V
Input Offset Voltage for OCP Comparators				5	mV
Leakage Current (PGO)	$I_{(kg)}$	PGO = 5V		5	$\mu\text{A}$
Low-Level Output Voltage (PGO)	$V_{(OL)}$	$I_{(SINK)} = 10\text{mA}$ , $V_{DD} = 4.5\text{V}$		0.4	V
Short-Circuit Protection Delay	3.3V, 5V	49	75	114	ms
Delay Time	$t_{(d)(1)}$				
PGI to PGO		$V_{DD} = 5\text{V}$		450	ms
PGI to $\overline{FPO}$		$V_{DD} = 5\text{V}$		7.2	ms
Noise Deglitch Time					
PGI to PGO		$V_{DD} = 5\text{V}$		225	$\mu\text{s}$
12V UVP to $\overline{FPO}$		$V_{DD} = 5\text{V}$		225	$\mu\text{s}$
<b>PSON CONTROL</b>					
Input Pull-Up Current	$I_I$	$\overline{PSON} = 0\text{V}$		-120	$\mu\text{A}$
High-Level Input Voltage	$V_{IH}$	2.4			V
Low-Level Input Voltage	$V_{IL}$			1.2	V
Debounce Time ( $\overline{PSON}$ )	$t_{(b)}$	$V_{DD} = 5\text{V}$		50	ms
Delay Time ( $\overline{PSON}$ to $\overline{FPO}$ )	$t_{(d)(2)}$	$V_{DD} = 5\text{V}$		$t_b + 4$	ms
<b>TOTAL DEVICE</b>					
Supply Current	$I_{DD}$	$\overline{PSON} = 5\text{V}$		1	mA

**PIN CONFIGURATION**



**PIN ASSIGNMENTS**

PIN	NAME	FUNCTION
3	FPO	Inverted Fault Protection output. Open-drain output stage.
2	GND	Ground
5	IS12	12V Over-Current Protection Input
8	IS5	5V Over-Current Protection Input
9	IS33	3.3V Over-Current Protection Input
7	NC	No Internal Connection
1	PGI	Power-Good Input
14	PGO	Power-Good Output. Open-drain output stage.
4	PSON	On/Off Control Input
6	RI	OCF Reference Source
13	VDD	Supply Voltage
10	VS12	12V Over-Voltage/Under-Voltage Protection Input
11	VS33	3.3V Over-Voltage/Under-Voltage Protection Input
12	VS5	5V Over-Voltage/Under-Voltage Protection Input

**FUNCTION TABLE<sup>(1)</sup>**

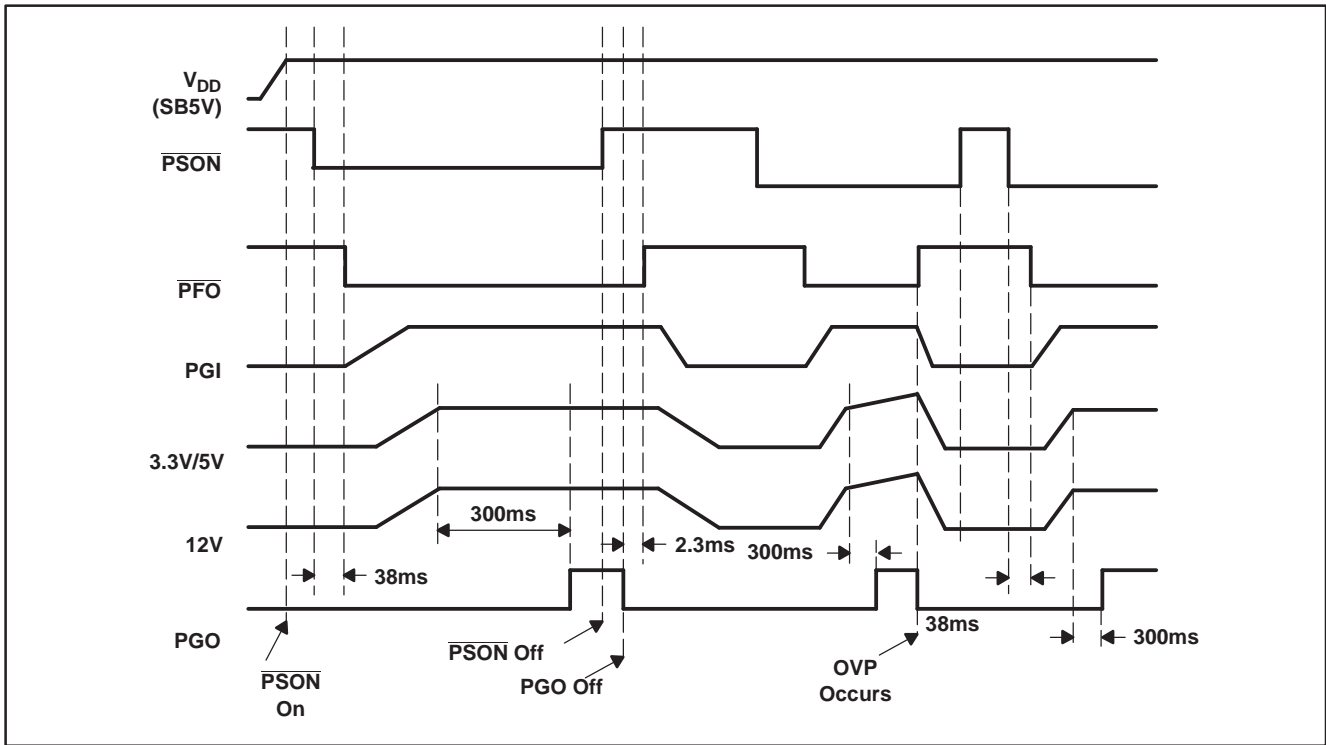
PGI	PSON	UV CONDITION 3.3V/5V	OV CONDITIONS	UV CONDITION 12V OC CONDITIONS	FPO <sup>(2)</sup>	PGO <sup>(3)</sup>
< 0.9V	L	No	No	No	L	L
< 0.9V	L	No	No	Yes	L	L
< 0.9V	L	No	Yes	No	H	L
< 0.9V	L	No	Yes	Yes	H	L
< 0.9V	L	Yes	No	No	L	L
< 0.9V	L	Yes	No	Yes	L	L
< 0.9V	L	Yes	Yes	No	H	L
< 0.9V	L	Yes	Yes	Yes	H	L
> 1.2V	L	No	No	No	L	H
> 1.2V	L	No	No	Yes	H	L
> 1.2V	L	No	Yes	No	H	L
> 1.2V	L	No	Yes	Yes	H	L
> 1.2V	L	Yes	No	No	H	L
> 1.2V	L	Yes	No	Yes	H	L
> 1.2V	L	Yes	Yes	No	H	L
> 1.2V	L	Yes	Yes	Yes	H	L
x	H	x	x	x	H	L

(1) x = Don't Care.

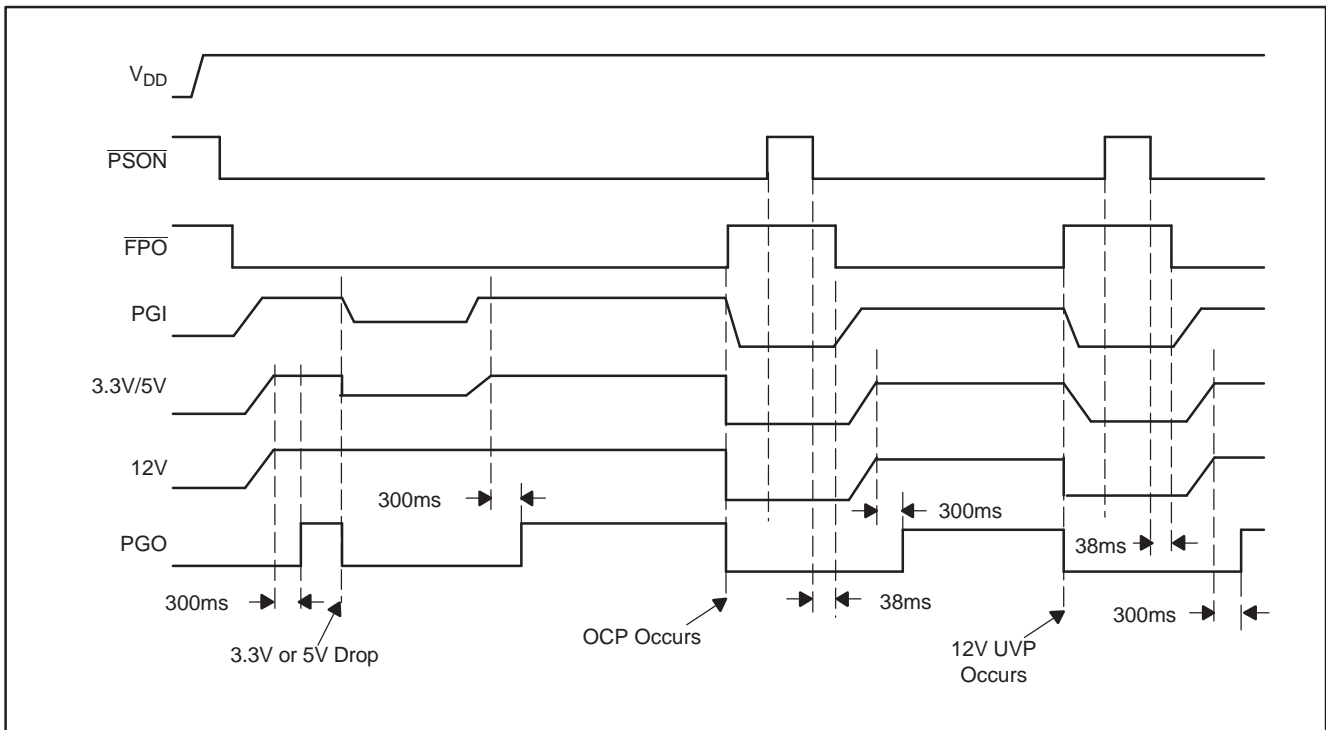
(2) For FPO, L = Fault is not latched. H = Fault is latched.

(3) For PGO, L = Fault. H = No Fault.

**TIMING DIAGRAMS**

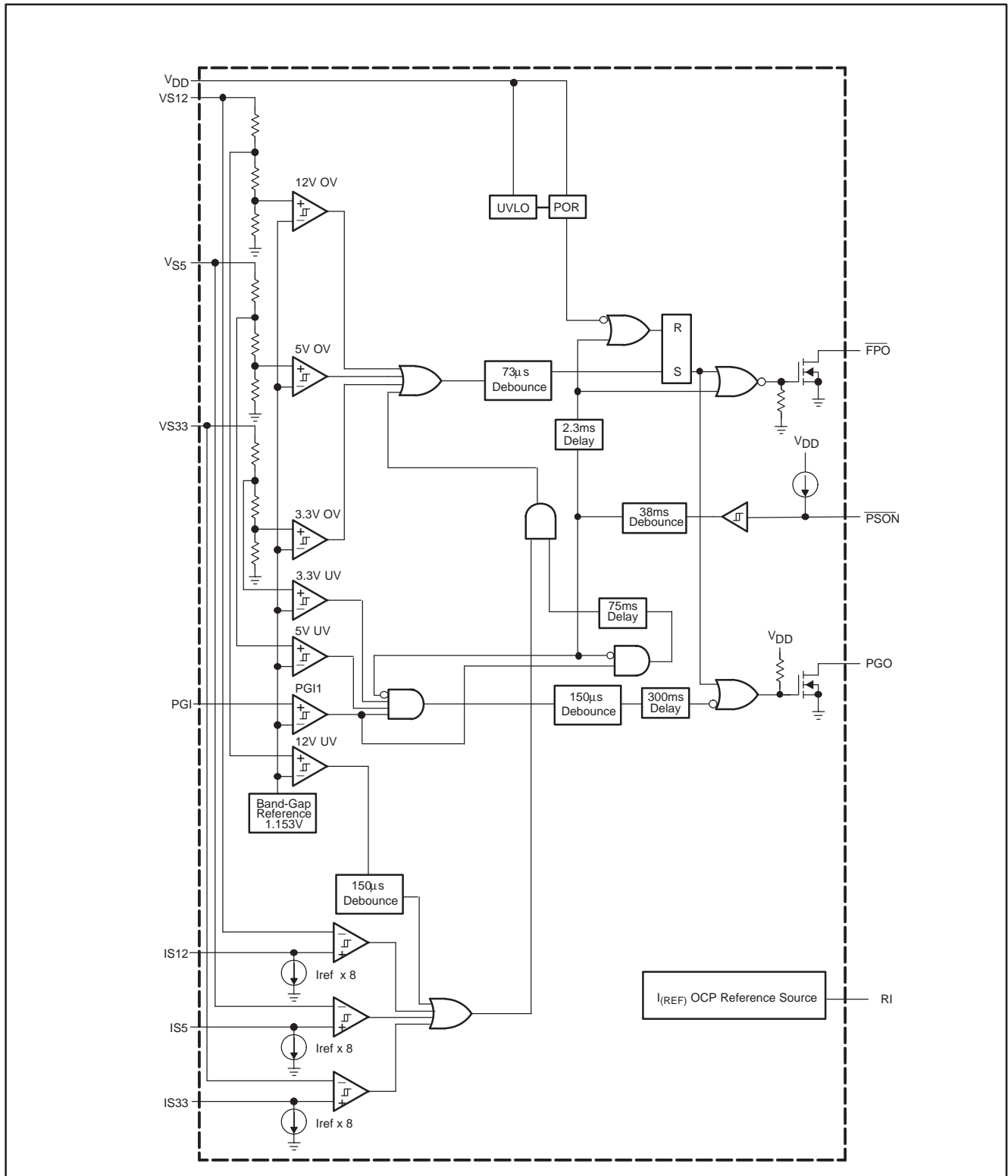


**Figure 1. AC Turn-On and Over-Voltage Protect**



**Figure 2. Over-Current and Under-Voltage Detect/Protect**

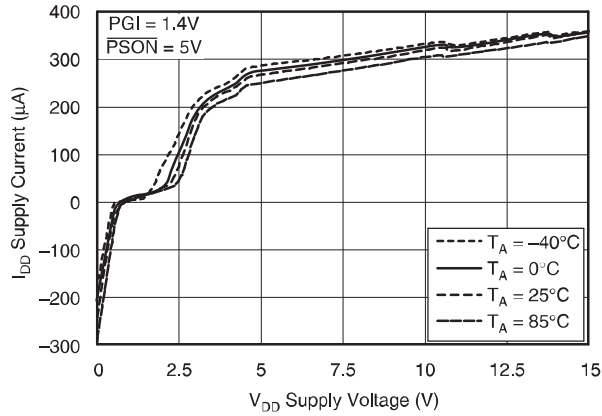
**SCHEMATIC**



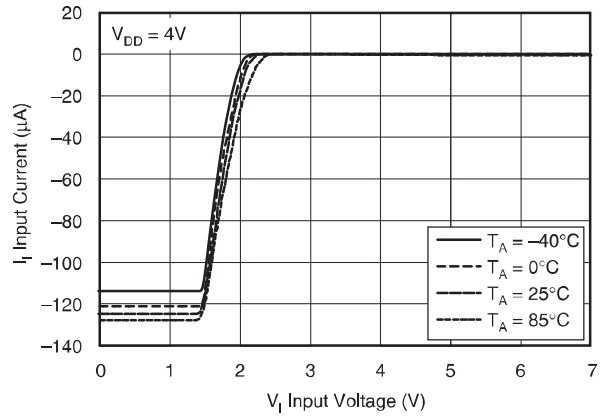
**TYPICAL CHARACTERISTICS**

$T_A = +25^\circ\text{C}$ , unless otherwise noted.

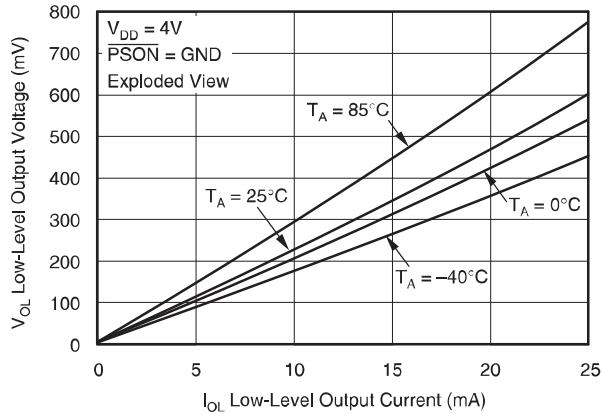
**SUPPLY CURRENT  
vs  
SUPPLY VOLTAGE**



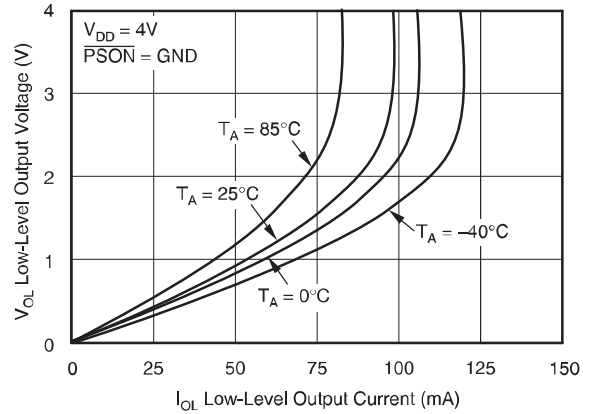
**INPUT CURRENT ( $\overline{\text{PSON}}$ )  
vs  
INPUT VOLTAGE ( $\overline{\text{PSON}}$ )**



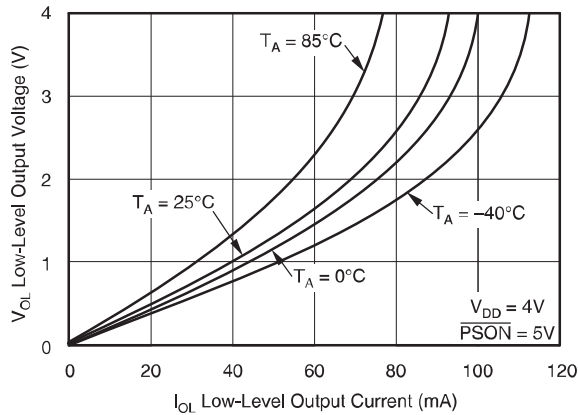
**LOW-LEVEL OUTPUT VOLTAGE ( $\overline{\text{FPO}}$ )  
vs  
LOW-LEVEL OUTPUT CURRENT ( $\overline{\text{FPO}}$ )**



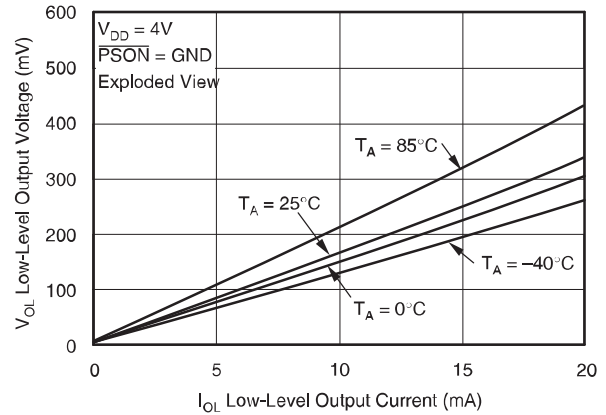
**LOW-LEVEL OUTPUT VOLTAGE ( $\overline{\text{FPO}}$ )  
vs  
LOW-LEVEL OUTPUT CURRENT ( $\overline{\text{FPO}}$ )**



**LOW-LEVEL OUTPUT VOLTAGE ( $\overline{\text{PGO}}$ )  
vs  
LOW-LEVEL OUTPUT CURRENT ( $\overline{\text{PGO}}$ )**



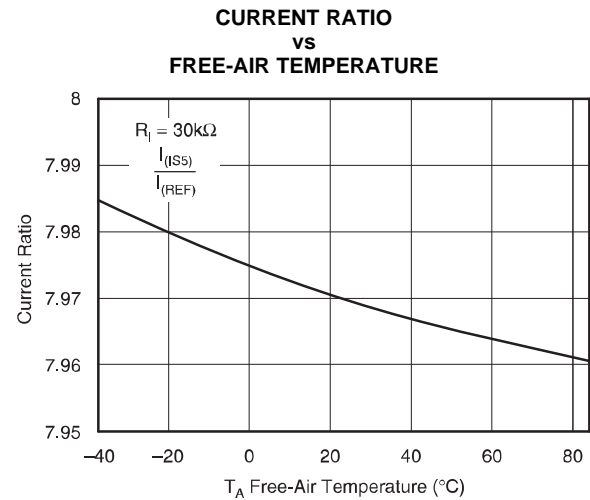
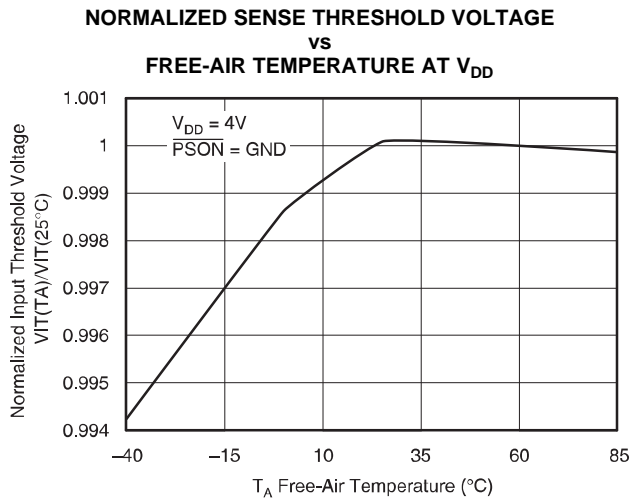
**LOW-LEVEL OUTPUT VOLTAGE ( $\overline{\text{PGO}}$ )  
vs  
LOW-LEVEL OUTPUT CURRENT ( $\overline{\text{PGO}}$ )**





## TYPICAL CHARACTERISTICS (continued)

$T_A = +25^\circ\text{C}$ , unless otherwise noted.



## DETAILED DESCRIPTION

### Power-Good and Power-Good Delay

A PC power supply is commonly designed to provide a power-good signal, which is defined by the computer manufacturers. Power-Good Output (PGO) is a power-good indicator and should be asserted high by the PC power supply to indicate that the 5VDC and 3.3VDC outputs are above the under-voltage threshold limit. At this time, the supply should be able to provide enough power to assure continuous operation within the specification.

Conversely, when either the 5VDC or the 3.3VDC output voltages fall below the under-voltage threshold, or when main power has been removed for a sufficiently long time so that power-supply operation is no longer assured, PGO should be deasserted to a low state. The power-good, DC enable ( $\overline{\text{PSON}}$ ), and the 5V/3.3V supply rails are shown in Figure 3.

Although there is no requirement to meet specific timing parameters, the following signal timings are recommended:

$$2\text{ms} \leq t_2 \leq 20\text{ms}, \quad 100\text{ms} < t_3 < 2000\text{ms}, \quad t_4 > 1\text{ms}, \quad t_5 \leq 10\text{ms}$$

Furthermore, motherboards should be designed to comply with the above recommended timing. If timings other than these are implemented or required, this information should be clearly specified.

The TPS3514 family of power-supply supervisors provides a PGO for the 3.3V and 5V supply voltage rails and a separate Power-Good Input (PGI). An internal timer is used to generate a 300ms power-good delay.

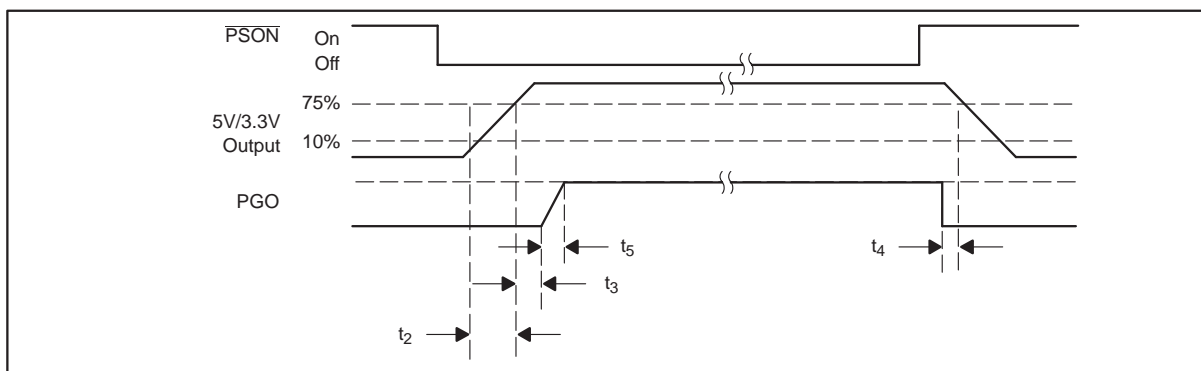


Figure 3. Timing of  $\overline{\text{PSON}}$  and PGO

If the voltage signals at PGI, VS33, and VS5 rise above the under-voltage threshold, the open-drain PGO will go high after a delay of 300ms. When the PGI voltage or any of the 3.3V/5V rail drops below the under-voltage threshold, PGO will be disabled immediately.

### Power-Supply Remote On/Off ( $\overline{\text{PSON}}$ ) And Fault Protect Output ( $\overline{\text{FPO}}$ )

Since the latest personal computer generation focuses on easy turn-on and power-saving functions, the PC power supply will require two characteristics. One is a DC power-supply remote on/off function; the other is standby voltage to achieve very low power consumption of the PC system. Thus, requiring the main power supply to be shut down.

The power-supply remote on/off ( $\overline{\text{PSON}}$ ) is an active-low signal that turns on all of the main power rails including the 3.3V, 5V, -5V, and -12V power rails. When this signal is held high by the PC motherboard or left open-circuited, the signal of the Fault Protect Output ( $\overline{\text{FPO}}$ ) also goes high. In this condition, the main power rails should not deliver current and should be held at 0V.

When the  $\overline{\text{FPO}}$  signal is held high due to an occurring fault condition, the fault status will be latched and the outputs of the main power rails should not deliver current and should be held at 0V. Toggling  $\overline{\text{PSON}}$  from low to high will reset the fault protection latch. During this fault condition, only the standby power is not affected.

When  $\overline{\text{PSON}}$  goes from high to low or low to high, the 38ms debounce block will prevent a glitch on the input from disabling/enabling the  $\overline{\text{FPO}}$  output. During the HIGH to LOW transition, the under-voltage function is disabled to prevent turn-on failure.

Power should be delivered to the rails only if the  $\overline{\text{PSON}}$  signal is held at ground potential, thus,  $\overline{\text{FPO}}$  is active low. The  $\overline{\text{FPO}}$  pin can be connected to 5VDC (or up to 15VDC) through a pull-up resistor.

### Under-Voltage Protection (UVP)

The TPS3514 provides Under-Voltage Protection (UVP) for the 12V rail and Under-Voltage Detect (UVD) for the 3.3V and 5V rails. When an under-voltage condition appears at the VS12 input pin for more than 150 $\mu$ s, the  $\overline{\text{FPO}}$  output goes high and PGO goes low. Also, this fault condition will be latched until  $\overline{\text{PSON}}$  is toggled from low to high or  $V_{\text{DD}}$  is removed.

### Over-Current Protection (OCP)

In bridge, or forward type, off-line switching power supplies, usually designed for medium to large power, the overload protection design needs to be very precise. Most of these types of power supplies sense the output current for an overload condition. The trigger-point needs to be set higher than the maximum load in order to prevent false turn-on.

The TPS3514 provides Over-Current Protection (OCP) for the 3.3V, 5V, and 12V rails. When an over-current condition appears at the OCP comparator input pins for more than 73 $\mu$ s, the  $\overline{\text{FPO}}$  output goes high and PGO goes low. Also, this fault condition will be latched until  $\overline{\text{PSON}}$  is toggled from low to high or  $V_{\text{DD}}$  is removed.

The resistor connected between the RI pin and the GND pin will create a precise  $I_{\text{(REF)}}$  for the OCP function. The formula for choosing the RI resistor is  $V_{\text{(RI)}}/I_{\text{(REF)}}$ . The  $I_{\text{(REF)}}$  range is from 12.5 $\mu$ A to 62.5 $\mu$ A. Three OCP comparators and the  $I_{\text{(REF)}}$  section are supplied through the V12 pin. Current drawn from the VS12 pin is less than 1mA.

Following is an example on calculating OCP for the 12V rail:

$$RI = V_{\text{(RI)}}/I_{\text{(REF)}} = 1.15\text{V}/20\mu\text{A} = 56\text{k}\Omega$$

$$I_{\text{(REF)}} \cdot C \cdot R_{\text{(IS12)}} = R_{\text{(SENSE)}} \cdot I_{\text{(OCP\_TRIP)}}$$

$$I_{\text{(OCP\_TRIP)}} = 20\mu\text{A} \cdot 8 \cdot 560\Omega / 0.01\Omega = 9.2\text{A}$$

$$C = \text{Current Ratio (typically} = 8)$$

### Over-Voltage Protection (OVP)

The Over-Voltage Protection (OVP) of the TPS3514 monitors 3.3V, 5V, and 12V. When an over-voltage condition appears at one of the 3.3V, 5V, or 12V input pins for more than 73 $\mu$ s, the  $\overline{\text{FPO}}$  output goes high and PGO goes low. Also, this fault condition will be latched until  $\overline{\text{PSON}}$  is toggled from low-to-high or  $V_{\text{DD}}$  is removed.

During fault conditions, most power supplies have the potential to deliver higher output voltages than those normally specified or required. In unprotected equipment, it is possible for output voltages to be high enough to cause internal or external damage of the system. To protect the system under these abnormal conditions, it is common practice to provide over-voltage protection within the power supply.

**PACKAGING INFORMATION**

Orderable Device	Status (1)	Package Type	Package Drawing	Pins	Package Qty	Eco Plan (2)	Lead/Ball Finish (6)	MSL Peak Temp (3)	Op Temp (°C)	Device Marking (4/5)	Samples
TPS3514D	ACTIVE	SOIC	D	14	50	Green (RoHS & no Sb/Br)	CU NIPDAU	Level-1-260C-UNLIM	-40 to 85	TPS3514D	<a href="#">Samples</a>
TPS3514DR	ACTIVE	SOIC	D	14	2500	Green (RoHS & no Sb/Br)	CU NIPDAU	Level-1-260C-UNLIM	-40 to 85	TPS3514D	<a href="#">Samples</a>
TPS3514N	ACTIVE	PDIP	N	14	25	Green (RoHS & no Sb/Br)	CU NIPDAU	N / A for Pkg Type	-40 to 85	TPS3514N	<a href="#">Samples</a>

(1) The marketing status values are defined as follows:

**ACTIVE:** Product device recommended for new designs.

**LIFEBUY:** TI has announced that the device will be discontinued, and a lifetime-buy period is in effect.

**NRND:** Not recommended for new designs. Device is in production to support existing customers, but TI does not recommend using this part in a new design.

**PREVIEW:** Device has been announced but is not in production. Samples may or may not be available.

**OBSOLETE:** TI has discontinued the production of the device.

(2) **RoHS:** TI defines "RoHS" to mean semiconductor products that are compliant with the current EU RoHS requirements for all 10 RoHS substances, including the requirement that RoHS substance do not exceed 0.1% by weight in homogeneous materials. Where designed to be soldered at high temperatures, "RoHS" products are suitable for use in specified lead-free processes. TI may reference these types of products as "Pb-Free".

**RoHS Exempt:** TI defines "RoHS Exempt" to mean products that contain lead but are compliant with EU RoHS pursuant to a specific EU RoHS exemption.

**Green:** TI defines "Green" to mean the content of Chlorine (Cl) and Bromine (Br) based flame retardants meet JS709B low halogen requirements of <=1000ppm threshold. Antimony trioxide based flame retardants must also meet the <=1000ppm threshold requirement.

(3) MSL, Peak Temp. - The Moisture Sensitivity Level rating according to the JEDEC industry standard classifications, and peak solder temperature.

(4) There may be additional marking, which relates to the logo, the lot trace code information, or the environmental category on the device.

(5) Multiple Device Markings will be inside parentheses. Only one Device Marking contained in parentheses and separated by a "-" will appear on a device. If a line is indented then it is a continuation of the previous line and the two combined represent the entire Device Marking for that device.

(6) Lead/Ball Finish - Orderable Devices may have multiple material finish options. Finish options are separated by a vertical ruled line. Lead/Ball Finish values may wrap to two lines if the finish value exceeds the maximum column width.

**Important Information and Disclaimer:**The information provided on this page represents TI's knowledge and belief as of the date that it is provided. TI bases its knowledge and belief on information provided by third parties, and makes no representation or warranty as to the accuracy of such information. Efforts are underway to better integrate information from third parties. TI has taken and continues to take reasonable steps to provide representative and accurate information but may not have conducted destructive testing or chemical analysis on incoming materials and chemicals. TI and TI suppliers consider certain information to be proprietary, and thus CAS numbers and other limited information may not be available for release.

In no event shall TI's liability arising out of such information exceed the total purchase price of the TI part(s) at issue in this document sold by TI to Customer on an annual basis.

**TAPE AND REEL INFORMATION**



**QUADRANT ASSIGNMENTS FOR PIN 1 ORIENTATION IN TAPE**



\*All dimensions are nominal

Device	Package Type	Package Drawing	Pins	SPQ	Reel Diameter (mm)	Reel Width W1 (mm)	A0 (mm)	B0 (mm)	K0 (mm)	P1 (mm)	W (mm)	Pin1 Quadrant
TPS3514DR	SOIC	D	14	2500	330.0	16.4	6.5	9.0	2.1	8.0	16.0	Q1

**TAPE AND REEL BOX DIMENSIONS**



\*All dimensions are nominal

Device	Package Type	Package Drawing	Pins	SPQ	Length (mm)	Width (mm)	Height (mm)
TPS3514DR	SOIC	D	14	2500	333.2	345.9	28.6

N (R-PDIP-T\*\*)

PLASTIC DUAL-IN-LINE PACKAGE

16 PINS SHOWN



- NOTES:
- A. All linear dimensions are in inches (millimeters).
  - B. This drawing is subject to change without notice.
  - Falls within JEDEC MS-001, except 18 and 20 pin minimum body length (Dim A).
  - The 20 pin end lead shoulder width is a vendor option, either half or full width.

D (R-PDSO-G14)

PLASTIC SMALL OUTLINE



4040047-5/M 06/11

- NOTES:
- A. All linear dimensions are in inches (millimeters).
  - B. This drawing is subject to change without notice.
  -  Body length does not include mold flash, protrusions, or gate burrs. Mold flash, protrusions, or gate burrs shall not exceed 0.006 (0,15) each side.
  -  Body width does not include interlead flash. Interlead flash shall not exceed 0.017 (0,43) each side.
  - E. Reference JEDEC MS-012 variation AB.



D (R-PDSO-G14)

PLASTIC SMALL OUTLINE



4211283-3/E 08/12

- NOTES:
- All linear dimensions are in millimeters.
  - This drawing is subject to change without notice.
  - Publication IPC-7351 is recommended for alternate designs.
  - Laser cutting apertures with trapezoidal walls and also rounding corners will offer better paste release. Customers should contact their board assembly site for stencil design recommendations. Refer to IPC-7525 for other stencil recommendations.
  - Customers should contact their board fabrication site for solder mask tolerances between and around signal pads.

## IMPORTANT NOTICE

Texas Instruments Incorporated (TI) reserves the right to make corrections, enhancements, improvements and other changes to its semiconductor products and services per JESD46, latest issue, and to discontinue any product or service per JESD48, latest issue. Buyers should obtain the latest relevant information before placing orders and should verify that such information is current and complete.

TI's published terms of sale for semiconductor products (<http://www.ti.com/sc/docs/stdterms.htm>) apply to the sale of packaged integrated circuit products that TI has qualified and released to market. Additional terms may apply to the use or sale of other types of TI products and services.

Reproduction of significant portions of TI information in TI data sheets is permissible only if reproduction is without alteration and is accompanied by all associated warranties, conditions, limitations, and notices. TI is not responsible or liable for such reproduced documentation. Information of third parties may be subject to additional restrictions. Resale of TI products or services with statements different from or beyond the parameters stated by TI for that product or service voids all express and any implied warranties for the associated TI product or service and is an unfair and deceptive business practice. TI is not responsible or liable for any such statements.

Buyers and others who are developing systems that incorporate TI products (collectively, "Designers") understand and agree that Designers remain responsible for using their independent analysis, evaluation and judgment in designing their applications and that Designers have full and exclusive responsibility to assure the safety of Designers' applications and compliance of their applications (and of all TI products used in or for Designers' applications) with all applicable regulations, laws and other applicable requirements. Designer represents that, with respect to their applications, Designer has all the necessary expertise to create and implement safeguards that (1) anticipate dangerous consequences of failures, (2) monitor failures and their consequences, and (3) lessen the likelihood of failures that might cause harm and take appropriate actions. Designer agrees that prior to using or distributing any applications that include TI products, Designer will thoroughly test such applications and the functionality of such TI products as used in such applications.

TI's provision of technical, application or other design advice, quality characterization, reliability data or other services or information, including, but not limited to, reference designs and materials relating to evaluation modules, (collectively, "TI Resources") are intended to assist designers who are developing applications that incorporate TI products; by downloading, accessing or using TI Resources in any way, Designer (individually or, if Designer is acting on behalf of a company, Designer's company) agrees to use any particular TI Resource solely for this purpose and subject to the terms of this Notice.

TI's provision of TI Resources does not expand or otherwise alter TI's applicable published warranties or warranty disclaimers for TI products, and no additional obligations or liabilities arise from TI providing such TI Resources. TI reserves the right to make corrections, enhancements, improvements and other changes to its TI Resources. TI has not conducted any testing other than that specifically described in the published documentation for a particular TI Resource.

Designer is authorized to use, copy and modify any individual TI Resource only in connection with the development of applications that include the TI product(s) identified in such TI Resource. NO OTHER LICENSE, EXPRESS OR IMPLIED, BY ESTOPPEL OR OTHERWISE TO ANY OTHER TI INTELLECTUAL PROPERTY RIGHT, AND NO LICENSE TO ANY TECHNOLOGY OR INTELLECTUAL PROPERTY RIGHT OF TI OR ANY THIRD PARTY IS GRANTED HEREIN, including but not limited to any patent right, copyright, mask work right, or other intellectual property right relating to any combination, machine, or process in which TI products or services are used. Information regarding or referencing third-party products or services does not constitute a license to use such products or services, or a warranty or endorsement thereof. Use of TI Resources may require a license from a third party under the patents or other intellectual property of the third party, or a license from TI under the patents or other intellectual property of TI.

TI RESOURCES ARE PROVIDED "AS IS" AND WITH ALL FAULTS. TI DISCLAIMS ALL OTHER WARRANTIES OR REPRESENTATIONS, EXPRESS OR IMPLIED, REGARDING RESOURCES OR USE THEREOF, INCLUDING BUT NOT LIMITED TO ACCURACY OR COMPLETENESS, TITLE, ANY EPIDEMIC FAILURE WARRANTY AND ANY IMPLIED WARRANTIES OF MERCHANTABILITY, FITNESS FOR A PARTICULAR PURPOSE, AND NON-INFRINGEMENT OF ANY THIRD PARTY INTELLECTUAL PROPERTY RIGHTS. TI SHALL NOT BE LIABLE FOR AND SHALL NOT DEFEND OR INDEMNIFY DESIGNER AGAINST ANY CLAIM, INCLUDING BUT NOT LIMITED TO ANY INFRINGEMENT CLAIM THAT RELATES TO OR IS BASED ON ANY COMBINATION OF PRODUCTS EVEN IF DESCRIBED IN TI RESOURCES OR OTHERWISE. IN NO EVENT SHALL TI BE LIABLE FOR ANY ACTUAL, DIRECT, SPECIAL, COLLATERAL, INDIRECT, PUNITIVE, INCIDENTAL, CONSEQUENTIAL OR EXEMPLARY DAMAGES IN CONNECTION WITH OR ARISING OUT OF TI RESOURCES OR USE THEREOF, AND REGARDLESS OF WHETHER TI HAS BEEN ADVISED OF THE POSSIBILITY OF SUCH DAMAGES.

Unless TI has explicitly designated an individual product as meeting the requirements of a particular industry standard (e.g., ISO/TS 16949 and ISO 26262), TI is not responsible for any failure to meet such industry standard requirements.

Where TI specifically promotes products as facilitating functional safety or as compliant with industry functional safety standards, such products are intended to help enable customers to design and create their own applications that meet applicable functional safety standards and requirements. Using products in an application does not by itself establish any safety features in the application. Designers must ensure compliance with safety-related requirements and standards applicable to their applications. Designer may not use any TI products in life-critical medical equipment unless authorized officers of the parties have executed a special contract specifically governing such use. Life-critical medical equipment is medical equipment where failure of such equipment would cause serious bodily injury or death (e.g., life support, pacemakers, defibrillators, heart pumps, neurostimulators, and implantables). Such equipment includes, without limitation, all medical devices identified by the U.S. Food and Drug Administration as Class III devices and equivalent classifications outside the U.S.

TI may expressly designate certain products as completing a particular qualification (e.g., Q100, Military Grade, or Enhanced Product). Designers agree that it has the necessary expertise to select the product with the appropriate qualification designation for their applications and that proper product selection is at Designers' own risk. Designers are solely responsible for compliance with all legal and regulatory requirements in connection with such selection.

Designer will fully indemnify TI and its representatives against any damages, costs, losses, and/or liabilities arising out of Designer's non-compliance with the terms and provisions of this Notice.