

## 3.8V-36V Vin, 5A, High Efficiency Synchronous Step-down DCDC Converter with Programmable Frequency

### FEATURES

- Wide Input Range: 3.8V-36V
- Up to 5A Continuous Output Current
- Integrated 45mΩ High-Side and 20mΩ Low-Side Power MOSFETs
- Feedback Reference Voltage: 0.8V ±1%
- Adjustable Frequency 100KHz to 1.1MHz
- Precision Enable Threshold for Programmable Input Voltage Under-voltage Lock Out Protection (UVLO) Threshold and Hysteresis
- Minimum On-time: 100ns
- Internal Soft-start Time: 4ms
- Over-voltage and Over-Temperature Protection
- Pulse Skipping Mode (PSM) with 25uA Quiescent Current in Sleep Mode
- External Clock Synchronization
- Low Dropout Mode Operation
- Derivable Inverting Voltage Regulator
- Frequency Spread Spectrum (FSS) Modulation for EMI Reduction
- Available in an ESOP-8 Package

### APPLICATIONS

- Battery Pack Powered System - Cordless Power Tools, Cordless Home Appliance, Drone, Aero Modeling, GPS Tracker etc.
- Cigarette Lighter Adapters, Chargers
- LCD Display
- USB Type-C Power Delivery, USB Charging
- Industrial and Medical Distributed Power Supplies
- Optical Communication and Networking System
- Automotive System

### DESCRIPTION

The TPS54540D is 5A synchronous buck converters with wide input voltage, ranging from 3.8V to 36V, which integrates a 45mΩ high-side MOSFET and a 20mΩ low-side MOSFET. The TPS54540D, adopting the peak current mode control, supports the Pulse Skipping Modulation (PSM) with typical 25uA low quiescent current which assists the converter on achieving high efficiency at light load or standby condition.

The TPS54540D features programmable switching frequency from 100 kHz to 1.1 MHz with an external resistor, which provides the flexibility to optimize either efficiency or external component size. The converter supports external clock synchronization with a frequency band from 100kHz to 1.1MHz. The TPS54540D allows power conversion from high input voltage to low output voltage with a minimum 100ns on-time of highside MOSFET, and support Low Dropout Mode Operation(LDO).

The TPS54540D is an Electromagnetic Interference (EMI) friendly buck converter with internal integration Frequency Spread Spectrum(FSS) for EMI reduction.

The TPS54540D offers cycle-by-cycle current limit and hiccup over current protection, thermal shutdown protection, output over-voltage protection and input voltage under-voltage protection. The device is available in an 8-pin thermally enhanced ESOP-8 package.

## FUNCTIONAL BLOCK DIAGRAM

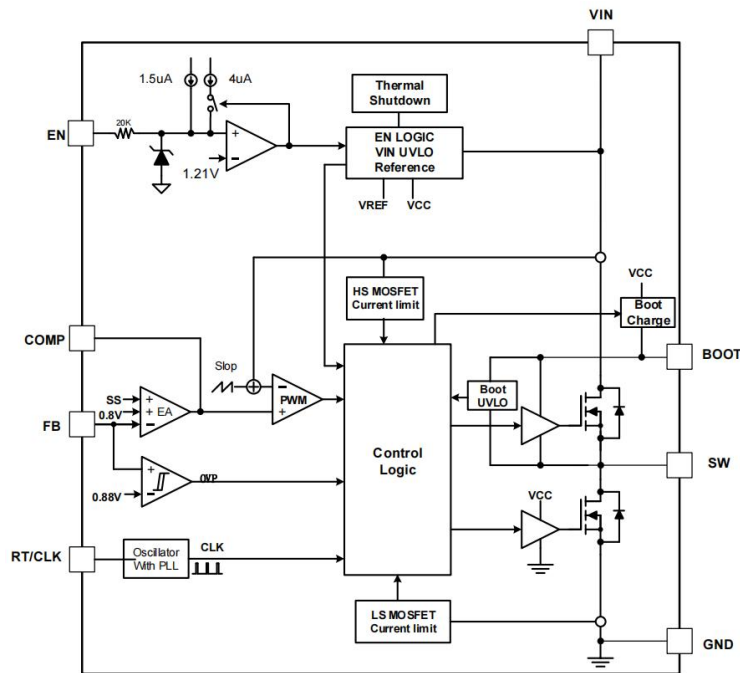

Figure 1. Functional Block Diagram

## ELECTRICAL CHARACTERISTICS

$V_{IN}=24V$ ,  $T_J=-40 \sim +125^{\circ}C$ , typical value is tested under  $25^{\circ}C$

SYMBOL	PARAMETER	TEST CONDITION	MIN	TYP	MAX	UNIT
$V_{IN}$	Operating input voltage		3.8		36	V
$V_{IN\_UVLO}$	Input UVLO Threshold	$V_{IN}$ rising		3.5	3.7	V
	Hysteresis			400		mV
$I_{SD}$	Shutdown current from $V_{IN}$ pin	EN=0V, no load		1	3	$\mu A$
$I_Q$	Quiescent current from $V_{IN}$ pin	ENfloating, no load, $V_{BST}-V_{SW}=5V$		25		$\mu A$
$R_{DSON\_H}$	High-side MOSFET on-resistance	$V_{BST}-V_{SW}=5V$		45		m $\Omega$
$R_{DSON\_L}$	Low-side MOSFET on-resistance			20		m $\Omega$
$V_{REF}$	Reference voltage of FB		0.792	0.80	0.808	V
$G_{EA}$	Error amplifier trans-conductance	$2\mu A < I_{COMP} < 2\mu A$ , $V_{COMP}=1V$		300		$\mu S$
$I_{COMP\_SRC}$	EA maximum source current	$V_{FB}=V_{REF}-100mV$ , $V_{COMP}=1V$		30		$\mu A$
$I_{COMP\_SNK}$	EA maximum sink current	$V_{FB}=V_{REF}+100mV$ , $V_{COMP}=1V$		30		$\mu A$
$V_{COMP\_H}$	COMP high clamp			3		V
$V_{COMP\_L}$	COMP low clamp			0.4		V
$I_{LIM\_HS}$	High-side power MOSFET peak current limit threshold		6.8	8	9.2	A
$I_{LIM\_LSSRC}$	Low-side power MOSFET sourcing current limit threshold			9		A
$t_{HIC\_W}$	Over current protection hiccup wait time			512		cycles

$t_{HIC\_R}$	Over current protection hiccup restart time			8192		cycles
$V_{EN\_H}$	Enable high threshold			1.18	1.25	V
$V_{EN\_L}$	Enable low threshold		1.03	1.1		V
$I_{EN\_L}$	Enable pin pull-up current	EN=1V	1	1.5	2	$\mu$ A
$I_{EN\_H}$	Enable pin pull-up current	EN=1.5V		5.5		$\mu$ A
$t_{ss}$	Internal soft start time			4		ms
$F_{RANGE\_RT}$	Frequency range using RT mode		100		1100	KHz
$F_{SW}$	Switching frequency	$R_{RT}=200\text{ k}\Omega(1\%)$	400	450	500	KHz
$F_{RANGE\_CLK}$	Frequency range using CLK mode		100		1100	KHz
$F_{JITTER}$	Frequency spread spectrum in percentage of Fsw			$\pm 6$		%
$t_{ON\_MIN}$	Minimum on-time	$V_{IN}=24V$		100		ns
$V_{OVP}$	Feedback overvoltage with respect to reference voltage	$V_{FB}/V_{REF}$ rising		110		%
		$V_{FB}/V_{REF}$ falling		105		%
$V_{BOOTUV}$	BOOT-SW UVLO threshold	$V_{BST}-V_{SW}$ rising		2.36		V
	Hysteresis	$V_{BST}-V_{SW}$ falling		300		mV
$T_{SD}$	Thermal shutdown threshold	$T_J$ rising		170		$^{\circ}$ C
	Hysteresis			25		$^{\circ}$ C

### ABSOLUTE MAXIMUM RATINGS

DESCRIPTION	VALUE	UNIT
$V_{IN}, V_{EN}$	38	V
$V_{BOOT}$	44	V
$V_{SW}$	38	V
$V_{FB}, V_{COMP}, V_{RT/CLK}$	6	V
$V_{BOOT}-V_{SW}$	6	V
Operating junction temperature $T_J$	-40 ~ +150	$^{\circ}$ C
Storage temperature $T_S$	-65 ~ +150	$^{\circ}$ C

### RECOMMENDED OPERATING CONDITIONS

DESCRIPTION	VALUE	UNIT
Input voltage range $V_{IN}$	3.8~36	V
Output voltage range $V_{OUT}$	0.8~35	V
Operating junction temperature $T_J$	-40 ~ +125	$^{\circ}$ C

### ESD RATINGS

DESCRIPTION	VALUE	UNIT
Human Body Model(HBM), ANSI-JEDEC-JS-001-2014	-2~+2	KV
Charged Device Model(CDM), ANSI-JEDEC-JS-002-2014	-0.5~+0.5	KV

## TYPICAL CHARACTERISTICS

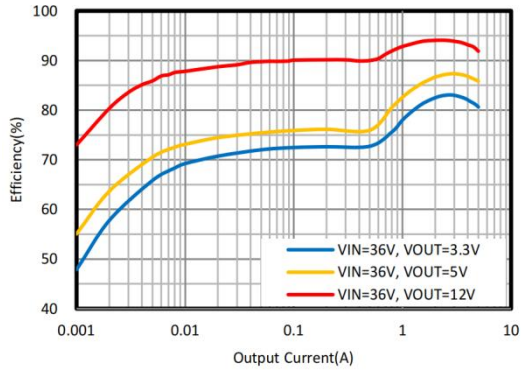

Figure 2. Efficiency vs Load Current,  $V_{in}=36V$

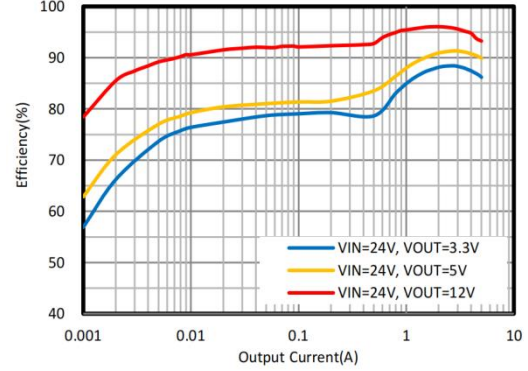

Figure 3. Efficiency vs Load Current,  $V_{in}=24V$

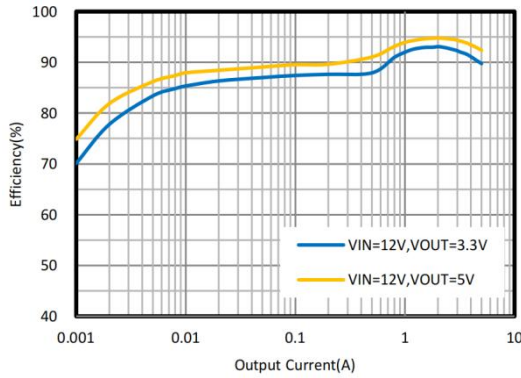

Figure 4. Efficiency vs Load Current,  $V_{in}=12V$

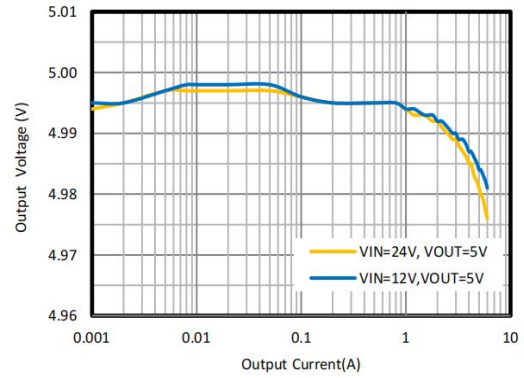

Figure 5. Load Regulation ( $V_{out}=5V$ )

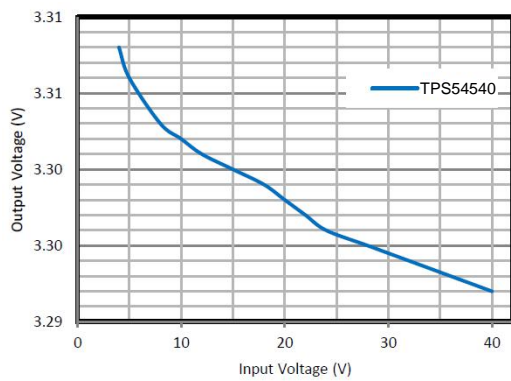

Figure 6. Line Regulation  $V_{OUT}=3.3V$ ,  $I_{LOAD}=5A$

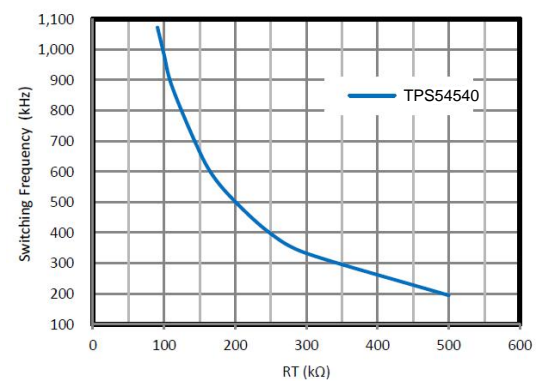

Figure 7. Clock Frequency vs  $R_T/CLK$  Resistor

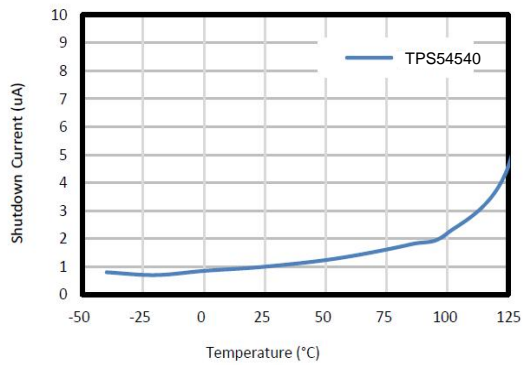

Figure 8. Shutdown Current vs Temperature

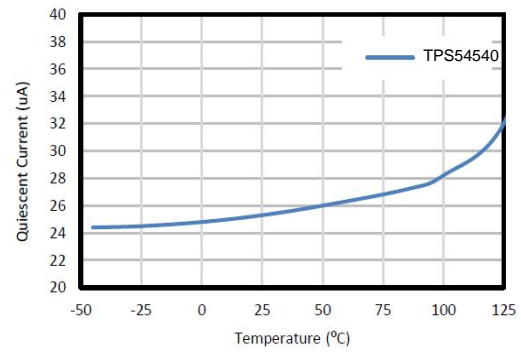

Figure 9. Quiescent Current vs Temperature

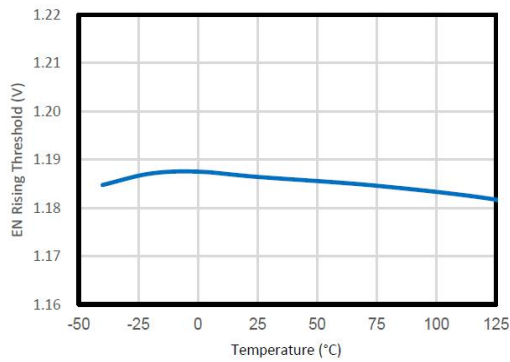

Figure 10. EN Threshold vs Temperature

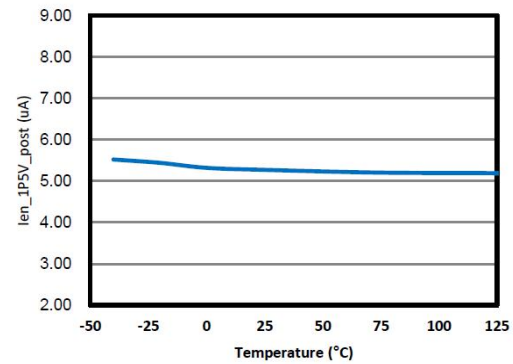

Figure 11. EN Pull-up Current vs Temperature

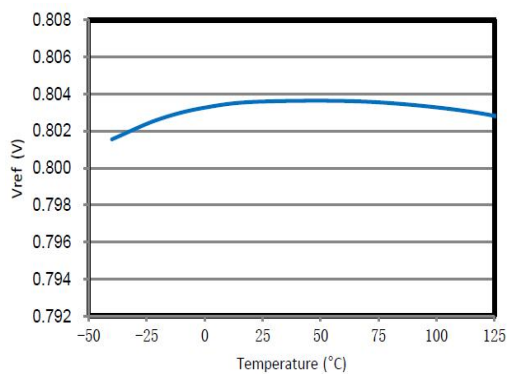

Figure 12. Reference Voltage vs Temperature

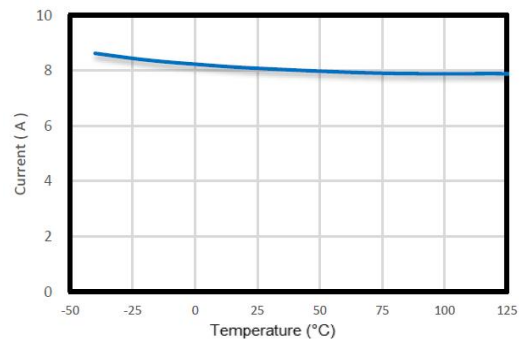

Figure 13. Peak Current Limit vs Temperature

## PIN CONFIGURATION

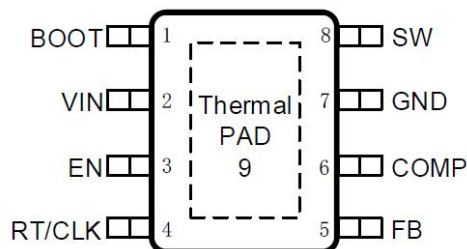

Figure 14. 8-Lead Plastic E-SOP

NO.	NAME	PIN FUNCTION
1	BOOT	Power supply bias for high-side power MOSFET gate driver. Connect a 0.1uF capacitor from BOOT pin to SW pin. Bootstrap capacitor is charged when low-side power MOSFET is on or SW voltage is low.
2	VIN	Input supply voltage. Connect a local bypass capacitor from VIN pin to GND pin. Path from VIN pin to high frequency bypass capacitor and GND must be as short as possible.
3	EN	Enable pin to the regulator with internal pull-up current source. Pull below 1.1V to disable the converter. Float or connect to VIN to enable the converter. The tap of resistor divider from VIN to GND connecting EN pin can adjust the input voltage lockout threshold.
4	RT/CLK	Set the 20internal oscillator clock frequency or synchronize to an external clock. Connect a resistor from this pin to ground to set switching frequency. An external clock can be input directly to the RT/CLK pin. The internal oscillator synchronizes to the external clock frequency with PLL. If detected clocking edges stops, the operation mode automatically returns to resistor programmed frequency.
5	FB	Inverting input of the trans-conductance error amplifier. The tap of external feedback resistor divider from the output to GND sets the output voltage. The device regulates FB voltage to the internal reference value of 0.8V typical.
6	COMP	Error amplifier output. Connect to frequency loop compensation network.
7	GND	Ground.
8	SW	Regulator switching output. Connect SW to an external power inductor.
9	Thermal Pad	Heat dissipation path of die. Electrically connection to GND pin. Must be connected to ground plane on PCB for proper operation and optimized thermal performance.

## TYPICAL APPLICATION

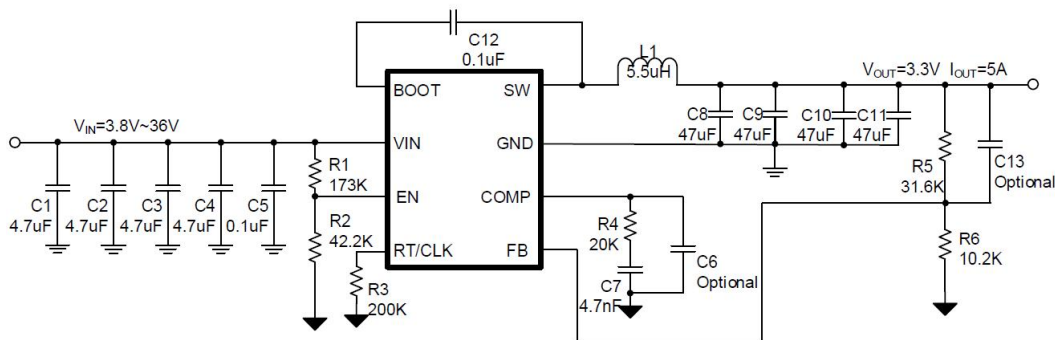

Figure 15. TPS54540D Design Example: 3.3V/3.5A Output, Switching frequency 500KHz

### Output Voltage:

$$V_{OUT} = 0.8 \cdot \frac{R_5 + R_6}{R_6}$$

### Switching Frequency:

$$f_{SW} (kHz) = \frac{100000}{R_3 (k\Omega)}$$

**Under Voltage Lock-Out:**

$$V_{rise} = 1.18 \times \left( 1 + \frac{R_1}{R_2} \right) - 1.5 \mu A \times R_1$$

$$V_{fall} = 1.10 \times \left( 1 + \frac{R_1}{R_2} \right) - 5.5 \mu A \times R_1$$

Compensation Values for Typical Output Voltage/Capacitor Combinations at fsw=500KHz:

Vout	L1	COUT	R4	C7	C6
1.8V	3.3uH	4*47uF	12.1K	6.8nF	100pF(optional)
2.5V	4.7uH	4*47uF	16.9K	4.7nF	68pF (optional)
3.3V	5.5uH	4*47uF	20K	4.7 nF	47pF (optional)
5V	7.8uH	4*47uF	34K	3.3nF	22pF (optional)
12V	10uH	4*47uF	54.9K	1nF	220pF

**Inverting Power application**

The TPS54540D can be used to convert a positive input voltage to a negative output voltage. Typical applications are amplifiers requiring a negative power supply.

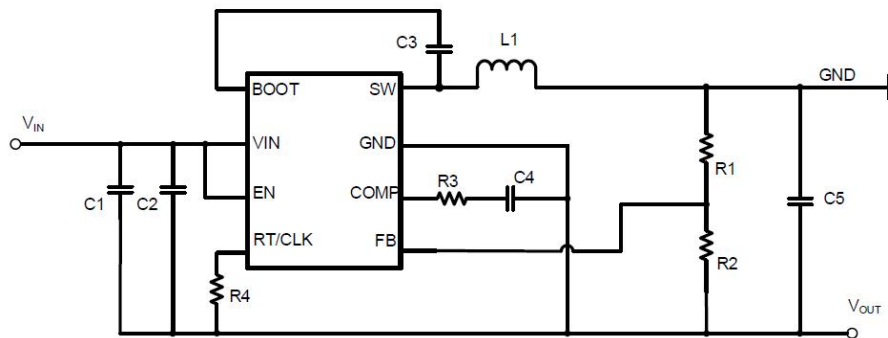
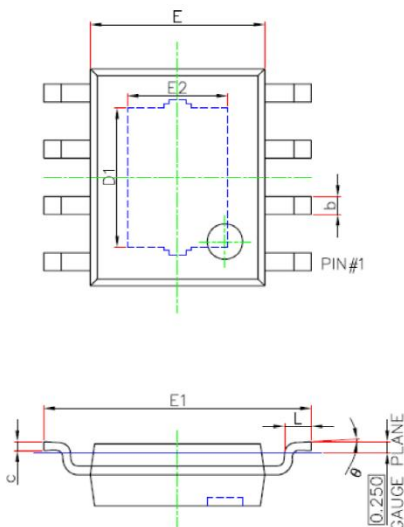

Figure 16. TPS54540D Inverting Power Supply

**PACKAGE INFORMATION**

Symbol	Dimensions in Millimeters	
	Min.	Max.
A	1.300	1.700
A1	0.000	0.100
A2	1.350	1.550
b	0.330	0.510
c	0.170	0.250
D	4.700	5.100
D1	3.050	3.250
E	3.800	4.000
E1	5.800	6.200
E2	2.160	2.360
e	1.270(BSC)	
L	0.400	1.270
θ	0°	8°

Figure 17. Package Outline Dimensions Of TPS54540D