

- Over Voltage Protection and Lock Out for 5 V, 3.3 V, and 12 V
- Under Voltage Protection and Lock Out for 5 V and 3.3 V
- Fault Protection Output with Open Drain Output Stage
- Open Drain Power Good Output Signal for Power Good Input, 5 V and 3.3 V
- 300 ms Power Good Delay
- 75 ms Delay for 5-V and 3.3-V Short-Circuit Turn On Protection
- 38 ms  $\overline{\text{PSON}}$  Control Debounce
- 73  $\mu\text{s}$  Width Noise Deglitches
- Wide Power Supply Voltage Range from 4 V to 15 V

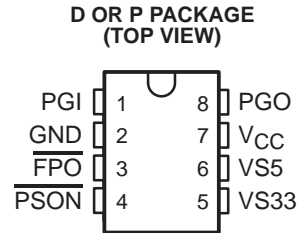

## description

The TPS5510 is designed to minimize external components of personal computer switching power supply systems. It provides protection circuits, power good indicator, fault protection output ( $\overline{\text{FPO}}$ ), and a  $\overline{\text{PSON}}$  control.

OVP (Over Voltage Protection) monitors 5 V, 3.3 V, and 12 V (12 V OV detects via V<sub>CC</sub> terminal). UVP (Under Voltage Protection) monitors 5 V and 3.3 V. When an OV or UV condition is detected, the PGO (power good output) is asserted low and  $\overline{\text{FPO}}$  is latched high.  $\overline{\text{PSON}}$  from low to high resets the protection latch. UVP function will be enabled 75 ms after  $\overline{\text{PSON}}$  is set low and debounced.

Power good feature monitors PGI, 5 V and 3.3 V and issues a power good signal when they are ready.

The TPS5510 is characterised for operation from T<sub>J</sub> = -40°C to 125°C junction temperature.

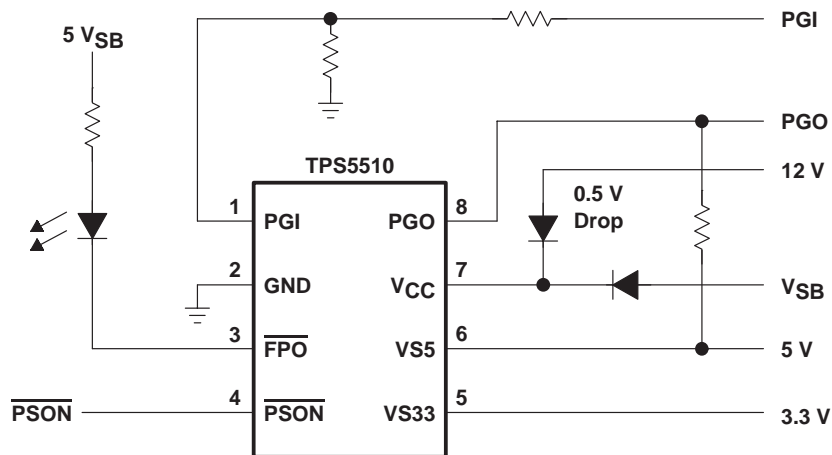

**Figure 1. TPS5510 Typical Application**



Please be aware that an important notice concerning availability, standard warranty, and use in critical applications of Texas Instruments semiconductor products and disclaimers thereto appears at the end of this data sheet.

# TPS5510

## 3-CHANNEL POWER SUPPLY SUPERVISOR

SLVS168 – JULY 1998

### functional block diagram

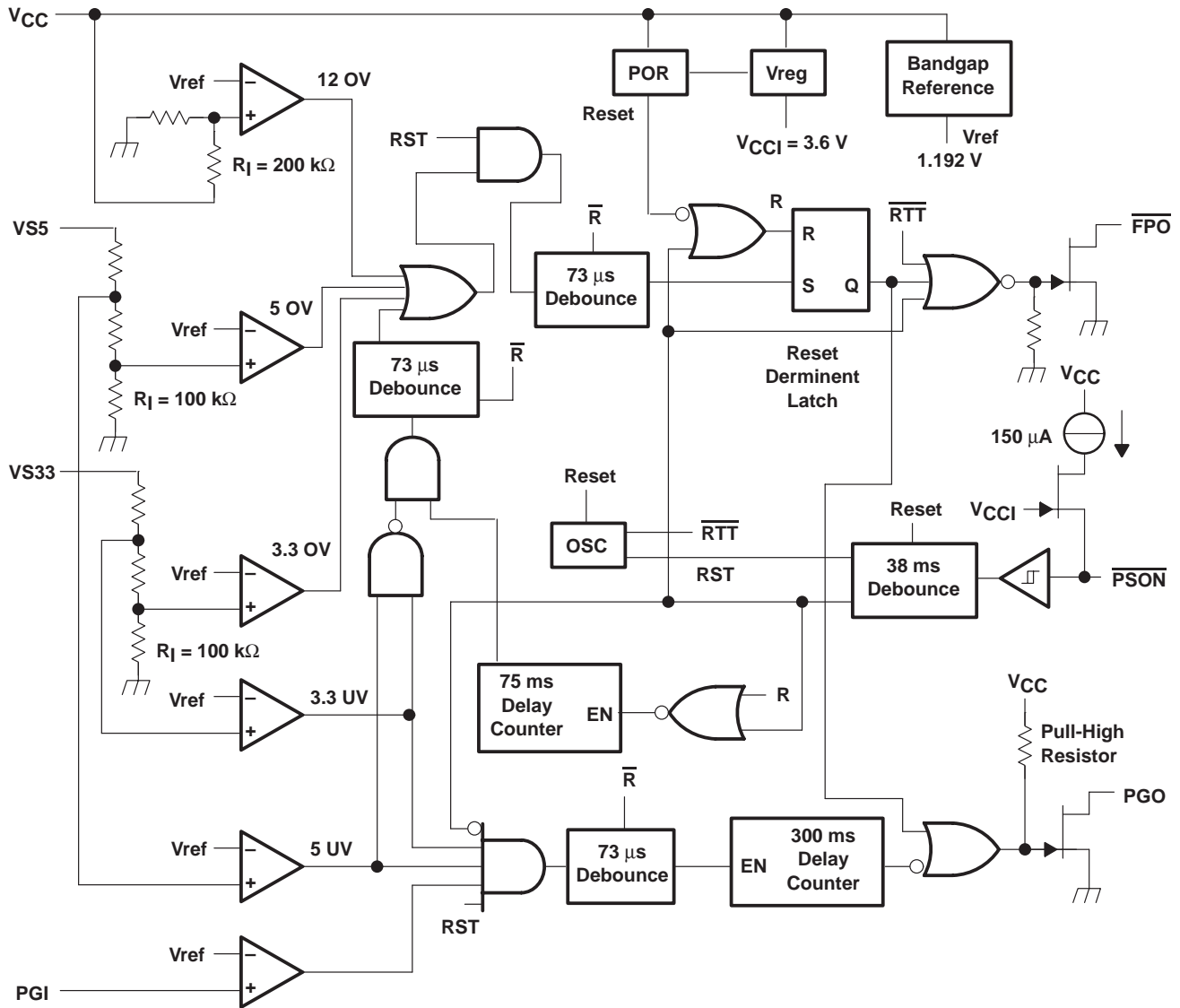

### Terminal Functions

TERMINAL NAME	NO.	I/O	DESCRIPTION
VS33	5	I	3.3 V over/under voltage protection input pin
VS5	6	I	5 V over/under voltage protection input pin
GND	2		Ground
$\overline{\text{FPO}}$	3	O	Inverted fault protection output, open drain output stage
PGI	1	I	Power good input signal pin
PGO	8	O	Power good output signal pin, open drain output stage
$\overline{\text{PSON}}$	4	I	ON/OFF control input pin
V <sub>CC</sub>	7	I	Supply voltage/12 V over voltage protection input pin

**DISSIPATION RATING TABLE**

PACKAGE	T <sub>A</sub> ≤ 25°C POWER RATING	OPERATING FACTOR ABOVE T <sub>A</sub> = 25°C	T <sub>A</sub> = 125°C POWER RATING
P	1092 mW	8.74 mW/°C	218 mW
D	730 mW	5.84 mW/°C	146 mW

### absolute maximum ratings over operating free-air temperature (unless otherwise noted)†

Supply voltage, V <sub>CC</sub> , (see Note 1)	16 V
Output voltage, V <sub>O</sub> (FPO)	16 V
Output voltage, V <sub>O</sub> (PGO)	8 V
Supply current, I <sub>CC</sub>	1 mA
Continuous total power dissipation	see Dissipation Rating Table
Operating junction temperature range, T <sub>J</sub>	–40°C to 125°C
Storage temperature range, T <sub>stg</sub>	–65°C to 150°C
Lead temperature, 1,6 mm (1/16 inch) from case for 10 seconds	260°C

† Stresses beyond those listed under “absolute maximum ratings” may cause permanent damage to the device. These are stress ratings only, and functional operation of the device at these or any other conditions beyond those indicated under “recommended operating conditions” is not implied. Exposure to absolute-maximum-rated conditions for extended periods may affect device reliability.

NOTE 1: All voltages are with respect to the device GND terminal.

### recommended operating conditions

	TEST CONDITIONS	MIN	TYP	MAX	UNIT
Supply voltage, V <sub>CC</sub>		4		15	V
Input voltage, V <sub>I</sub>	$\overline{\text{PSON}}$ , VS5, VS33, PGI			7	V
Output voltage, V <sub>O</sub>	$\overline{\text{FPO}}$			15	V
	PGO			7	V
Operating junction temperature, T <sub>J</sub>		–40		125	°C
Output sink current, I <sub>O(sink)</sub>	$\overline{\text{FPO}}$			30	mA
	PGO			10	mA
Supply voltage rising time, t <sub>r</sub>	See Note 2	1			ms

NOTE 2: V<sub>CC</sub> rising and falling slew rate must be less than 14 V/ms.

# TPS5510

## 3-CHANNEL POWER SUPPLY SUPERVISOR

SLVS168 – JULY 1998

electrical characteristics,  $V_{CC} = 5\text{ V}$ ,  $T_J = \text{full range}$ . (unless otherwise specified)

### over voltage protection

PARAMETER		TEST CONDITIONS	MIN	TYP	MAX	UNIT
Over-voltage threshold	VS33		3.9	4.1	4.3	V
	VS5		5.7	6.1	6.5	
	V <sub>CC</sub>		13.3	13.8	14.3	
I <sub>LKG</sub>	Leakage current ( $\overline{FPO}$ )	V( $\overline{FPO}$ ) = 5 V			5	μA
V <sub>OL</sub>	Low level output voltage ( $\overline{FPO}$ )	I <sub>sink</sub> = 10 mA			0.3	V
		I <sub>sink</sub> = 30 mA			0.7	

### PGI and PGO

PARAMETER		TEST CONDITIONS	MIN	TYP	MAX	UNIT
Input threshold voltage (PGI)			1.141	1.192	1.242	V
Under-voltage threshold	VS33		2.71	2.83	2.95	V
	VS5		4.1	4.3	4.47	
Short circuit protection delay time		3.3 V, 5 V	49	75	114	ms
I <sub>LKG</sub>	Leakage current (PGO)	PGO = 5 V			5	μA
V <sub>OL</sub>	Low level output voltage (PGO)	Sink current = 10 mA			0.4	V

### PSON control

PARAMETER		TEST CONDITIONS	MIN	TYP	MAX	UNIT
Input pull-up current		$\overline{PSON} = 0\text{ V}$		150		μA
High-level input voltage			2.4			V
Low-level input voltage					1.2	V

### total device

PARAMETER		TEST CONDITIONS	MIN	TYP	MAX	UNIT
I <sub>CC</sub>	Supply current	$\overline{PSON} = 5\text{ V}$			1	mA

### switching characteristics, $V_{CC} = 5\text{ V}$ , $T_J = \text{full range}$

PARAMETER		TEST CONDITIONS	MIN	TYP	MAX	UNIT
t <sub>d</sub>	Delay time (PGI to PGO)		200	300	450	ms
t <sub>b</sub>	De-bounce time ( $\overline{PSON}$ )		24	38	57	ms
Noise deglitch time			47	73	110	μs



timing chart

