

- Over Voltage Protection and Lock Out for 5 V, 3.3 V, and 12 V
- Fault Protection Output with Open Drain Output Stage
- Open Drain Power Good Output Signal for Power Good Input, 5 V and 3.3 V
- 300 ms Power Good Delay
- 2.3 ms $\overline{\text{PSON}}$ Control to $\overline{\text{FPO}}$ Turn-Off Delay
- 38 ms $\overline{\text{PSON}}$ Control Debounce
- 73 μs Width Noise Deglitches
- Wide Power Supply Voltage Range from 4 V to 15 V

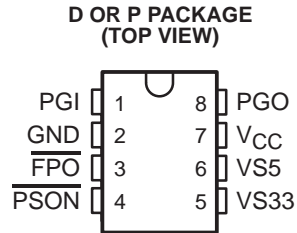

description

The TPS5511 is designed to minimize the external components of personal-computer switching power supply systems. It provides protection circuits, power good indicator, fault protection output ($\overline{\text{FPO}}$), and $\overline{\text{PSON}}$ control.

OVP (over voltage protection) monitors 5 V, 3.3 V, and 12 V (12 V OV detects via V_{CC} terminal). When an OV condition is detected, the PGO (power good output) is asserted low and $\overline{\text{FPO}}$ is latched high. $\overline{\text{PSON}}$ from low to high resets the protection latch. There is a 2.3-ms turn-off delay from $\overline{\text{PSON}}$ to $\overline{\text{FPO}}$. There is no delay during turn on.

Power good feature monitors PGI, 5 V and 3.3 V under voltages and issues a power good signal when they are ready.

The TPS5511 is characterized for operation from T_J = -40°C to 125°C junction temperature.

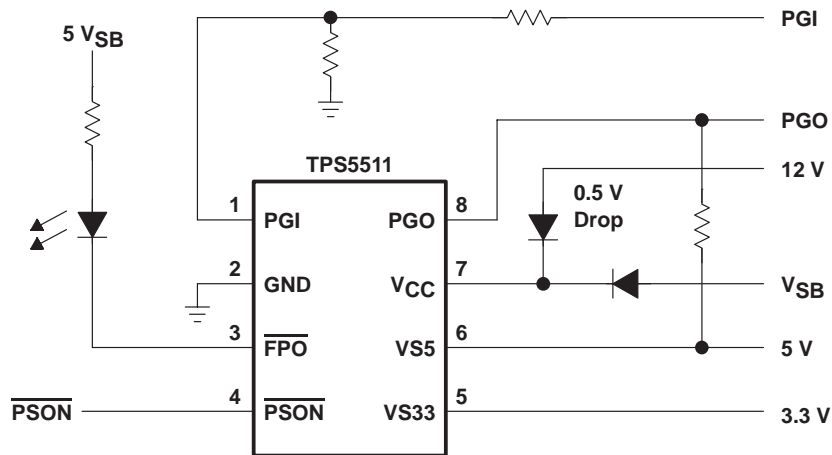

Figure 1. TPS5511 Typical Application



Please be aware that an important notice concerning availability, standard warranty, and use in critical applications of Texas Instruments semiconductor products and disclaimers thereto appears at the end of this data sheet.

Terminal Functions

TERMINAL NAME	NO.	I/O	DESCRIPTION
VS33	5	I	3.3 V over/under voltage protection input pin
VS5	6	I	5 V over/under voltage protection input pin
GND	2		Ground
$\overline{\text{FPO}}$	3	O	Inverted fault protection output, open drain output stage
PGI	1	I	Power good input signal pin
PGO	8	O	Power good output signal pin, open drain output stage
$\overline{\text{PSON}}$	4	I	ON/OFF control input pin
V _{CC}	7	I	Supply voltage/12 V over voltage protection input pin

DISSIPATION RATING TABLE

PACKAGE	T _A ≤ 25°C POWER RATING	OPERATING FACTOR ABOVE T _A = 25°C	T _A = 125°C POWER RATING
P	1092 mW	8.74 mW/°C	218 mW
D	730 mW	5.84 mW/°C	146 mW

absolute maximum ratings over operating free-air temperature (unless otherwise noted)†

Supply voltage, V _{CC} , (see Note 1)	16 V
Output voltage, V _O (FPO)	16 V
Output voltage, V _O (PGO)	8 V
Supply current, I _{CC}	1 mA
Continuous total power dissipation	see Dissipation Rating Table
Operating junction temperature range, T _J	–40°C to 125°C
Storage temperature range, T _{stg}	–65°C to 150°C
Lead temperature, 1,6 mm (1/16 inch) from case for 10 seconds	260°C

† Stresses beyond those listed under “absolute maximum ratings” may cause permanent damage to the device. These are stress ratings only, and functional operation of the device at these or any other conditions beyond those indicated under “recommended operating conditions” is not implied. Exposure to absolute-maximum-rated conditions for extended periods may affect device reliability.

NOTE 1: All voltages are with respect to the device GND terminal.

recommended operating conditions

	TEST CONDITIONS	MIN	TYP	MAX	UNIT
Supply voltage, V _{CC}		4		15	V
Input voltage, V _I	$\overline{\text{PSON}}$, VS5, VS33, PGI			7	V
Output voltage, V _O	$\overline{\text{FPO}}$			15	V
	PGO			7	V
Operating junction temperature, T _J		–40		125	°C
Output sink current, I _{O(sink)}	$\overline{\text{FPO}}$			30	mA
	PGO			10	mA
Supply voltage rising time, t _r	See Note 2	1			ms

NOTE 2: V_{CC} rising and falling slew rate must be less than 14 V/ms.

TPS5511

3-CHANNEL POWER SUPPLY SUPERVISOR

SLVS170 – AUGUST 1998

electrical characteristics, $V_{CC} = 5\text{ V}$, $T_J = \text{full range}$. (unless otherwise specified)

over voltage protection

PARAMETER		TEST CONDITIONS	MIN	TYP	MAX	UNIT
Over-voltage threshold	VS33		3.9	4.1	4.3	V
	VS5		5.7	6.1	6.5	
	V _{CC}		13.3	13.8	14.3	
I _{LKG}	Leakage current (\overline{FPO})	$V(\overline{FPO}) = 5\text{ V}$			5	μA
V _{OL}	Low level output voltage (\overline{FPO})	I _{sink} = 10 mA			0.3	V
		I _{sink} = 30 mA			0.7	

PGI and PGO

PARAMETER		TEST CONDITIONS	MIN	TYP	MAX	UNIT
Input threshold voltage (PGI)			1.141	1.192	1.242	V
Under-voltage threshold	VS33		2.71	2.83	2.95	V
	VS5		4.1	4.3	4.47	
I _{LKG}	Leakage current (PGO)	PGO = 5 V			5	μA
V _{OL}	Low level output voltage (PGO)	Sink current = 10 mA			0.4	V

PSON control

PARAMETER		TEST CONDITIONS	MIN	TYP	MAX	UNIT
Input pull-up current		$\overline{PSON} = 0\text{ V}$		150		μA
High-level input voltage			2.4			V
Low-level input voltage					1.2	V

total device

PARAMETER		TEST CONDITIONS	MIN	TYP	MAX	UNIT
I _{CC}	Supply current	$\overline{PSON} = 5\text{ V}$			1	mA

switching characteristics, $V_{CC} = 5\text{ V}$, $T_J = \text{full range}$

PARAMETER		TEST CONDITIONS	MIN	TYP	MAX	UNIT
t _{d1}	Delay time (PGI to PGO)		200	300	450	ms
t _b	De-bounce time (\overline{PSON})		24	38	57	ms
Noise deglitch time			47	73	110	μs
t _{d2}	\overline{PSON} to \overline{FPO} delay time		t _b + 1.1	t _b + 2.3	t _b + 4	ms



timing chart

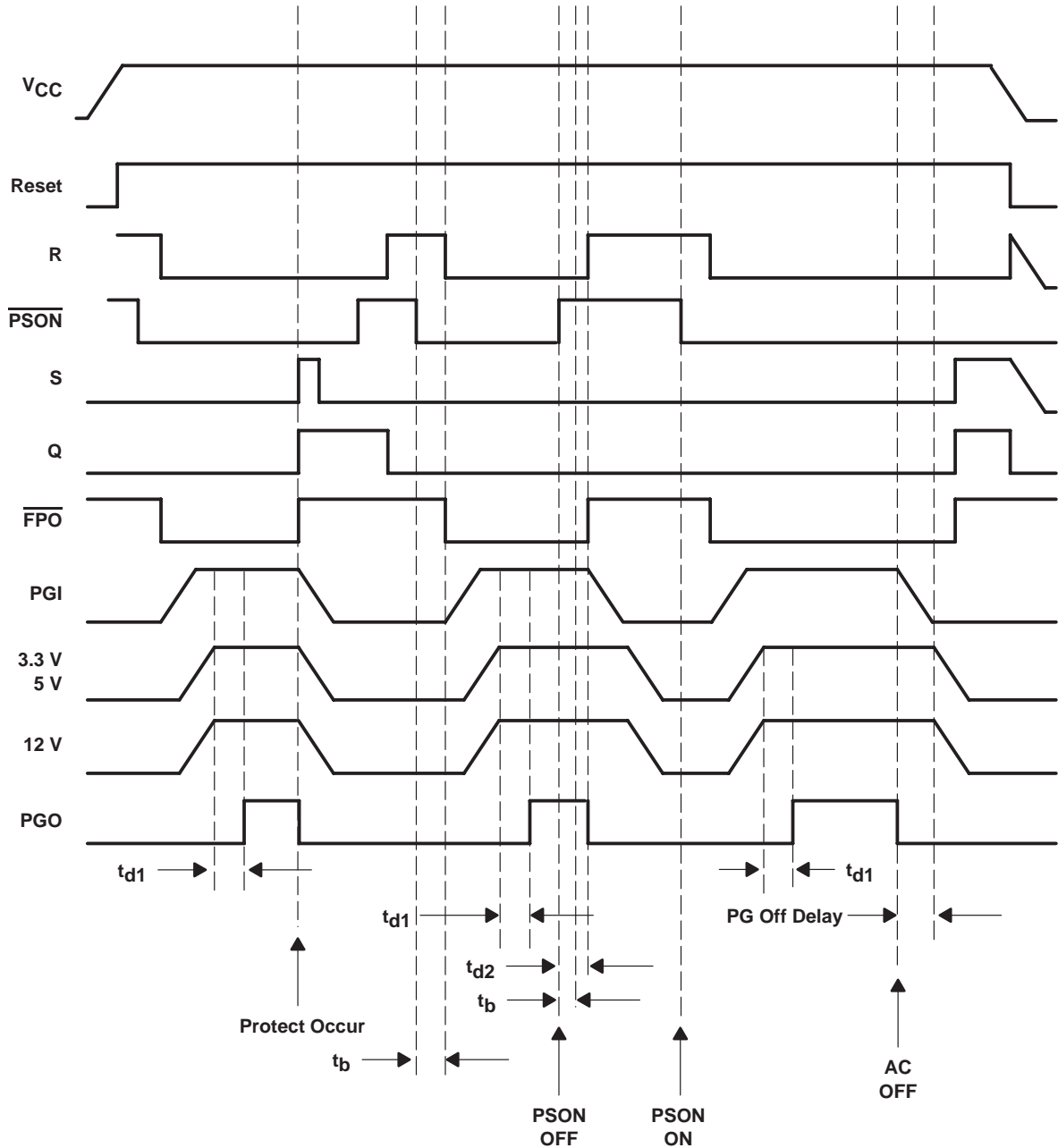

TPS5511 3-CHANNEL POWER SUPPLY SUPERVISOR

SLVS170 – AUGUST 1998

MECHANICAL DATA

D (R-PDSO-G**)

PLASTIC SMALL-OUTLINE PACKAGE

14 PIN SHOWN

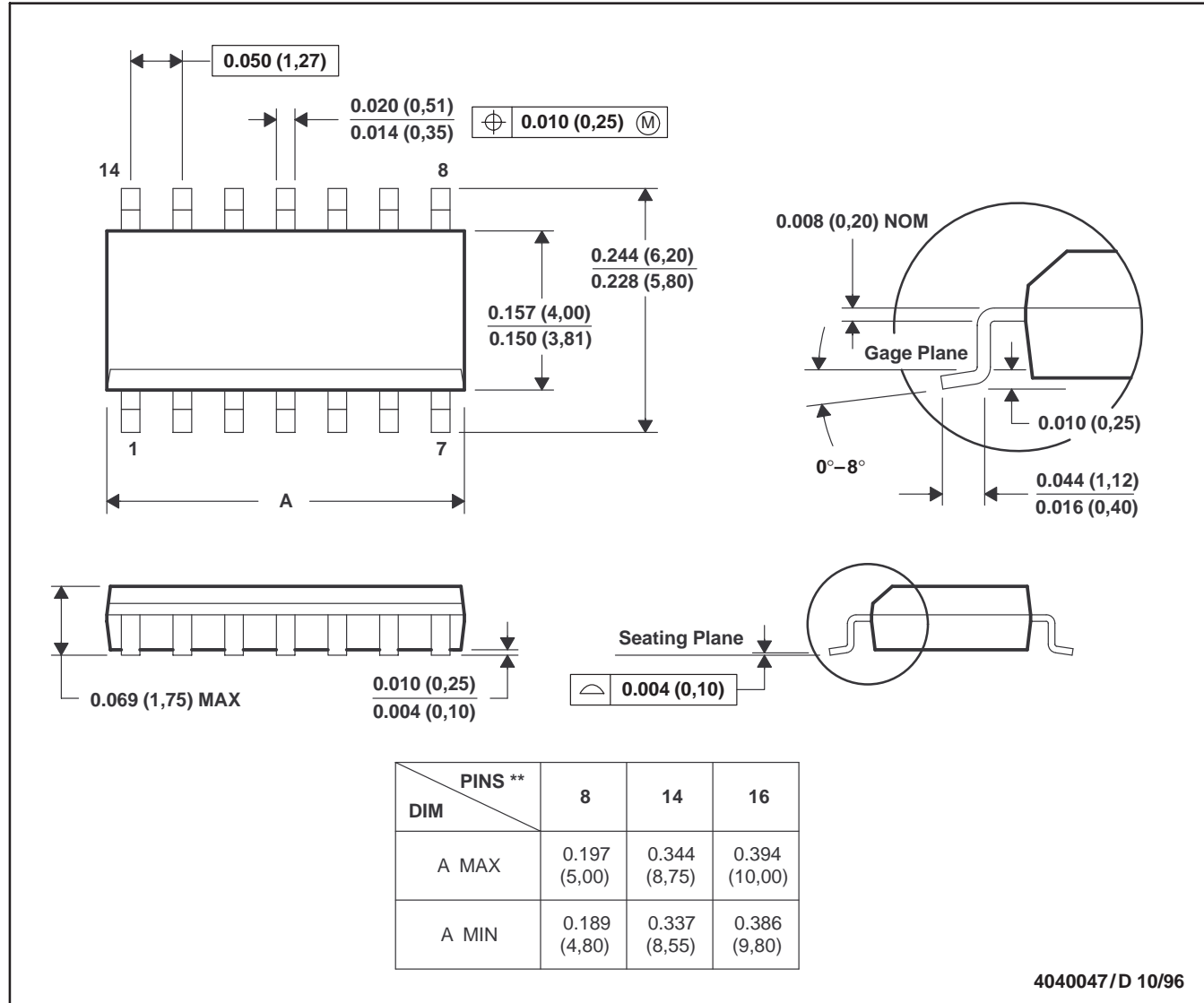

- NOTES: A. All linear dimensions are in inches (millimeters).
 B. This drawing is subject to change without notice.
 C. Body dimensions do not include mold flash or protrusion, not to exceed 0.006 (0,15).
 D. Falls within JEDEC MS-012

MECHANICAL DATA

P (R-PDIP-T8)

PLASTIC DUAL-IN-LINE PACKAGE

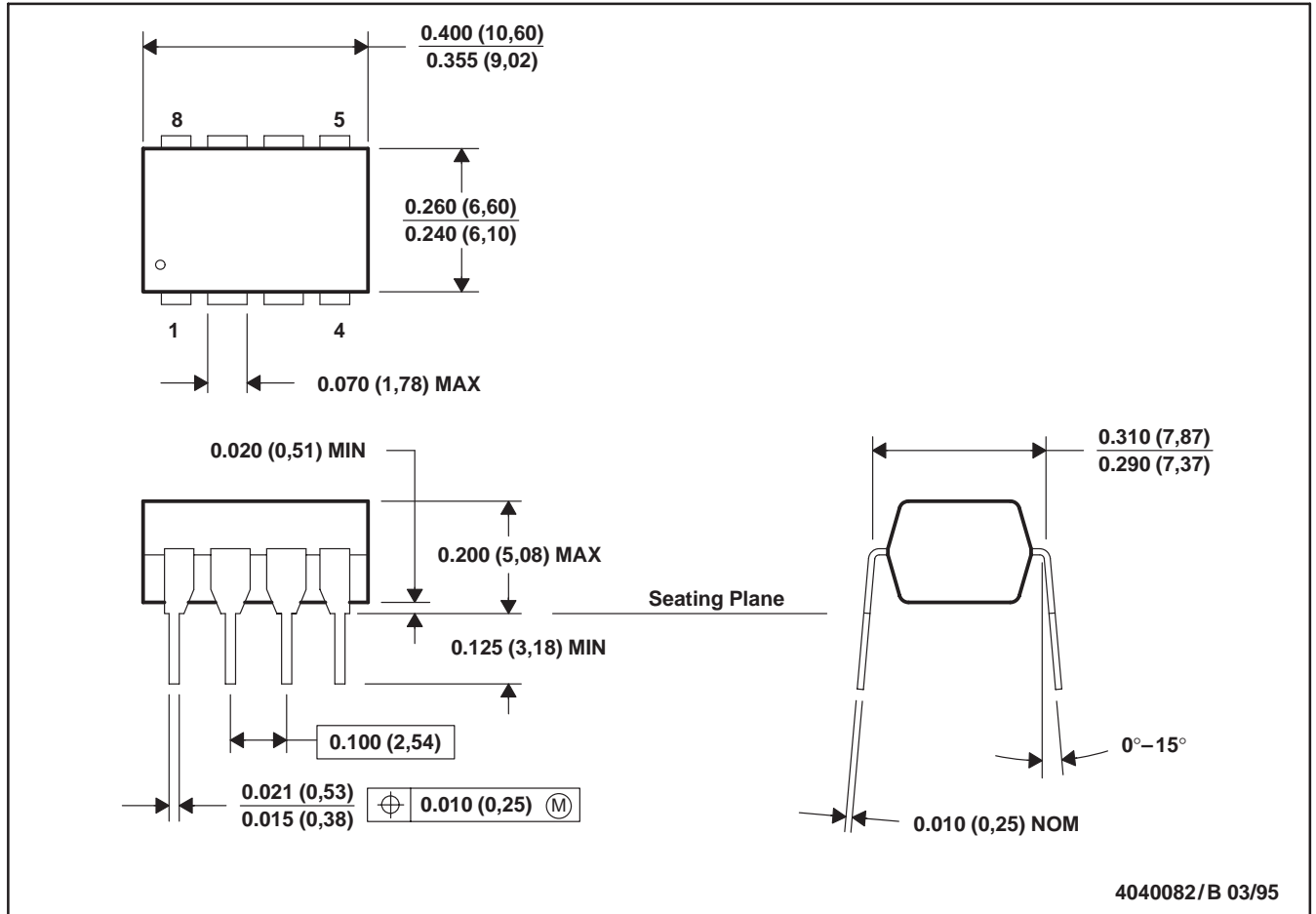

- NOTES: A. All linear dimensions are in inches (millimeters).
 B. This drawing is subject to change without notice.
 C. Falls within JEDEC MS-001