

GSM850/900 and DCS1800/PCS1900 Tx – Bandpass Filter

Features:

- Low insertion loss
- High suppression of 2nd, 3rd, 4th harmonics
- High selectivity
- Balanced to single-ended operation
- GSM Input: 310 Ohm balanced
PCN/PCS Input: 80 Ohm balanced
- 50 Ω single-ended output impedances.
- Integrated DC-biasing to input
- MLP 10L 3x3 package (3x3mm²)

Package Outline:

Dimensions in mm

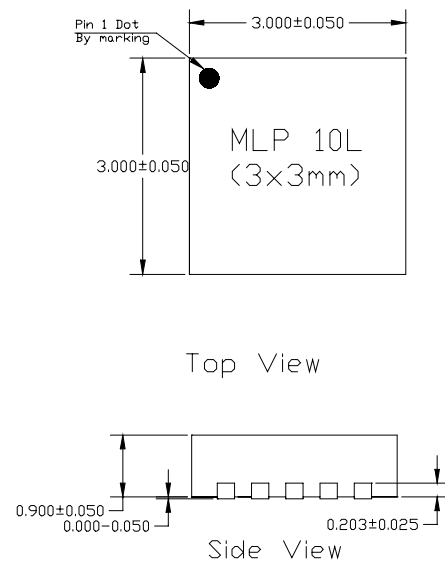

Application:

TX H2,H3,H4-Bandpass Filter / Balun for GSM850/900 and DCS/PCS systems

Description:

TQ1422 is a quadband capable TX bandpass filter for GSM850/E-GSM/DCS1800/PCS1900 applications. The integrated passive filter provides an optimum interface between the TQM7M4011/4012/4014 Power Amplifier Modules and direct conversion transceiver with balanced outputs. TQ1422 replaces up to 17 surface-mount components [including 2 Baluns and/or SAW filter] typically required on the phone board to provide similar functionality. High value inductors to supply open collector modulators are integrated.

Absolute Maximum Ratings:

Parameter	Min	Max	Unit
Maximum input power		25	dBm
Maximum bias current GSM		50mA($R_{max}=20\Omega$)	mA
Maximum bias current PCN/PCS		50mA($R_{max}=1.50\Omega$)	mA
Operation temperature range	-40	+85	°C
Storage temperature range	-60	+150	°C

Schematic:

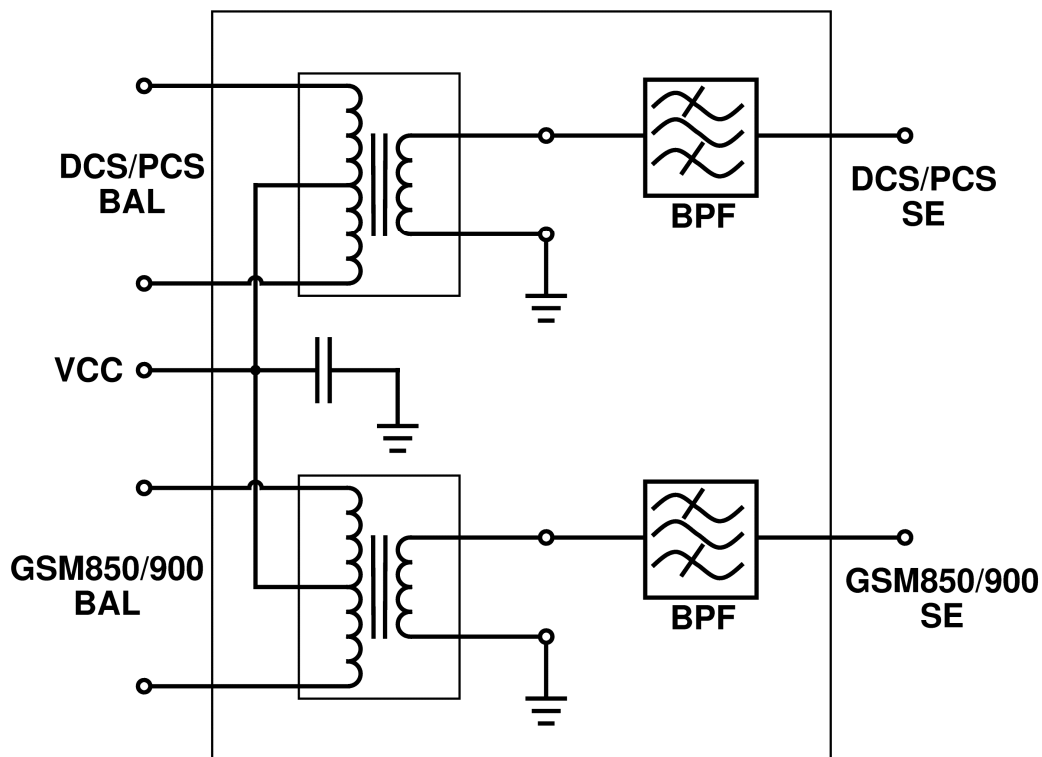

Electrical Specifications Low Band GSM850 / E-GSM

(T= 25°C)

Passband Parameter	Min.	Typ.	Max.	Unit
Passband		824-915		MHz
Insertion attenuation		1.90	2.1	dB
Insertion attenuation T= 85°C			2.25	dB
Ripple in Passband [any 40MHz]		0.075	0.20	dB
Differential input conductance		1 / 310		S
Differential input susceptance		-0.85		pF
Single ended output impedance		50		Ω
Amplitude balance		0.15		dB
Phase balance		180		deg
Inband VSWR Input		1.2	1.4	
Inband VSWR Output		1.6	1.8	

Stopband Parameter ($Z_{DIFF}=310\Omega -0.85pF; Z_{COMMON}=50\Omega; Z_{OUTPUT}=50\Omega$)				
Attenuation Differential Mode	Min.	Typ.	Max.	Unit
Dc ... 300 MHz	5	10		dB
1648 ... 1668 MHz	10	15		dB
1760 ... 1850 MHz	17	22		dB
2472 ... 2547 MHz [3x850]	40	45		dB
2640 ... 2775 MHz [3x900]	40	45		dB
3296 ... 3770 MHz [4xfc]	30	35		dB
2775 ... 8000 MHz	20	25		dB
Attenuation Common Mode	Min.	Typ.	Max.	Unit
100 ... 1400 MHz	30	35		dB
1648 ... 1668 MHz	30	35		dB
1760 ... 1850 MHz	30	35		dB
2472 ... 2547 MHz [3x850]	30	35		dB
2640 ... 2775 MHz [3x900]	25	30		dB
3296 ... 3770 MHz [4xfc]	17	22		dB
2775 ... 5000 MHz	17	22		dB
5000 ... 8000 MHz	5	10		dB

(T= 25°C)

Passband Parameter	Min.	Typ.	Max.	Unit
Passband		1710-1910		MHz
Insertion attenuation		2.6	3.1	dB
Insertion attenuation T= 85°C			3.3	dB
Ripple in Passband [any 80MHz]		0.25	0.35	dB
Differential input conductance		1 / 80		S
Differential input susceptance		-0.8		pF
Single ended output impedance		50		Ω
Amplitude balance		0.8		dB
Phase balance		175		deg
Inband VSWR Input		1.2	1.4	
Inband VSWR Output		1.4	1.6	

Stopband Parameter ($Z_{DIFF}=80\Omega -0.80pF;Z_{COMMON}=50\Omega;Z_{OUTPUT}=50\Omega$)				
Attenuation Differential Mode	Min.	Typ.	Max.	Unit
Dc ... 600 MHz	5	7		dB
3420 ... 5130 MHz	20	25		dB
5130 ... 5730 MHz [3xfc]	33	40		dB
5730 ... 10000 MHz	25	32		dB
Attenuation Common Mode	Min.	Typ.	Max.	Unit
100 ... 1710 MHz	8	13		dB
1710 ... 1910 MHz	15	20		dB
1910 ... 3420 MHz	25	30		dB
3420 ... 3820 MHz [2xfc]	28	33		dB
3820 ... 6840 MHz	28	33		dB
6840 ... 7640 MHz [4xfc]	18	25		dB
7640 ... 10000 MHz	5	10		dB

Pin Out:

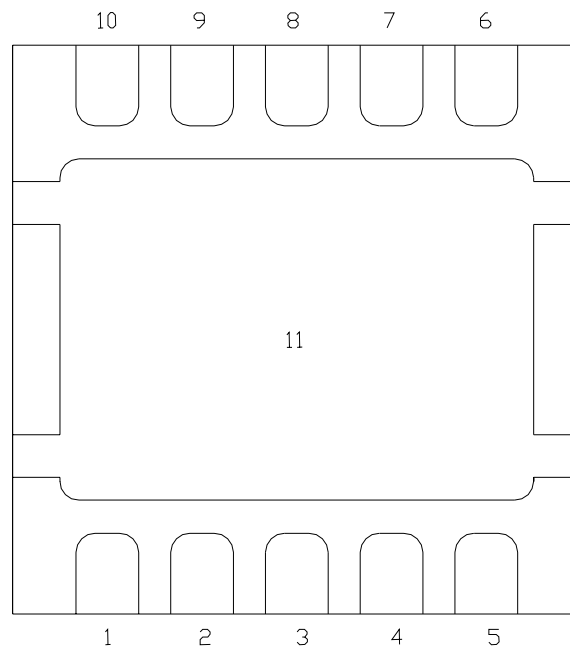

Pin #	Description	Function
1	DCS_IN1	DCS balanced input , 80Ohm -0.8pF @ 1810MHz
2	DCS_IN2	
3	VCC1	Input bias voltage *) ¹
4	GSM_IN1	GSM balanced input, 310Ohm -0.85pF @ 875MHz
5	GSM_IN2	
6	GSM_OUT	GSM single ended output, 50Ohm
7	GND	GSM isolated GND *) ²
8	VCC2	Input bias voltage *) ¹
9	GND	DCS isolated GND *) ²
10	DCS_OUT	DCS single ended output, 50Ohm
(11)	<i>Heat sink</i>	Common GND

*)¹ Either VCC1 or VCC2 needs to be connected. VCC1 and VCC2 are alternate inputs short-circuited on TQ1422.

*)² Isolated GND pins must not be connected to the heat sink directly. Use (separated) vias to connect to the PCB RF ground plane as close as possible !

Typical Performance

- GSM 850 / E-GSM:

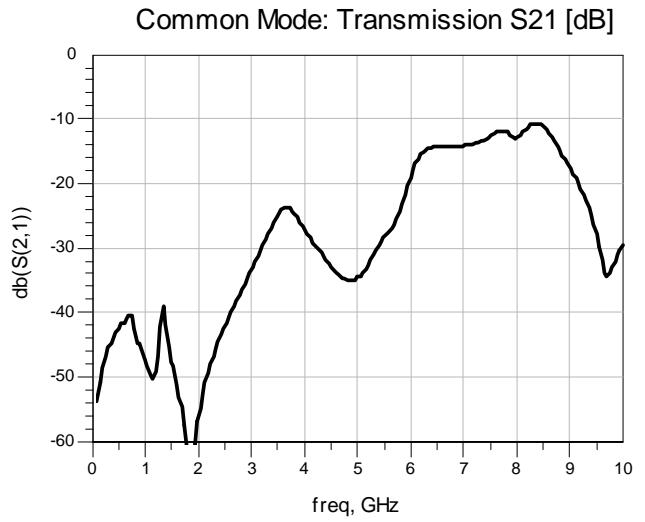
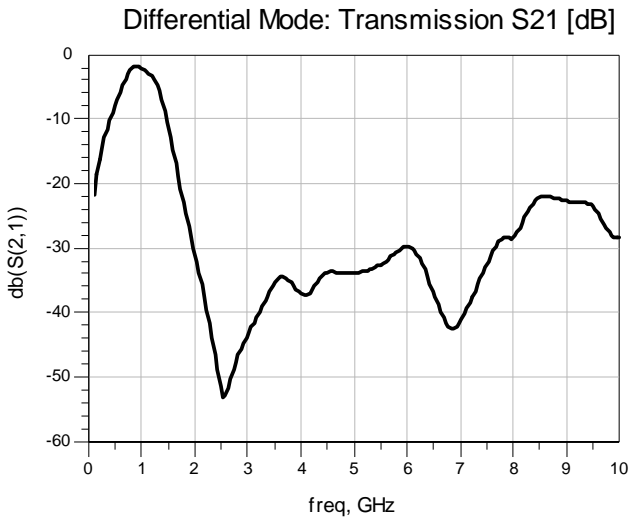

- DCS1800 / PCS1900:

