

**WCDMA / HSUPA Band IV Tritium III PA Duplexer Module™**

**Functional Block Diagram**

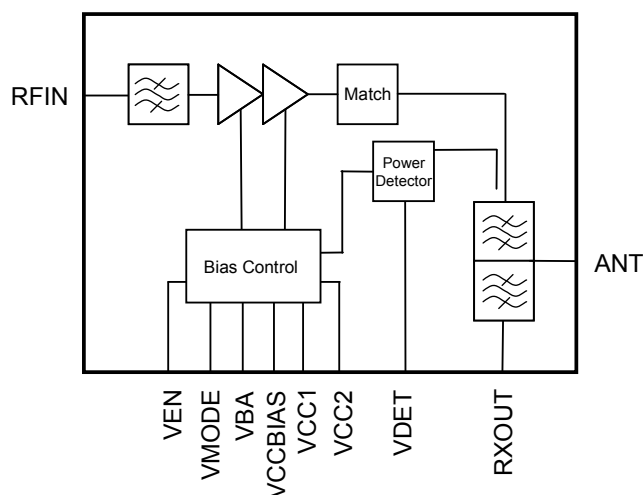

**Product Description**

The Tritium III PAD™ is an integrated 3V Linear Power Amplifier, Duplexer and Transmit Filter Module including a highly accurate Output Power Detector designed for mobile UMTS handset applications, supporting HSUPA operation with transmission data-rates up to 10Mb/s.

It features 2 output power modes, additional continuous bias in low power mode, low off and standby currents, and a separate pin for module enable. RF input and output matching is included within the module; therefore, minimal external circuitry is required. The Tritium III PAD™ gives excellent RF performance with low current consumption resulting in longer talk times in portable applications. The tiny 7x4x1.1 mm<sup>3</sup> surface mount package is ideal for new generation slim, small and light phones.

**Electrical Specifications**

Parameter	Min	Typ	Max	Units
Frequency	1710		1755	MHz
Linear P <sub>OUT</sub> (HSUPA) high power mode	25.0			dBm
Typical current high power mode		400		mA
Idle current low power mode		16		mA
ACPR (HSUPA) 5 MHz		-43		dBc
ALPR (HSUPA) 10 MHz		-60		dBc
Ant-to-RX Insertion Loss		2.2		dB

Test Conditions: V<sub>CC1</sub> = V<sub>CC2</sub> = 3.8 V, T<sub>a</sub> = 25°C

**Data Sheet**

For additional information and latest specifications, see our website: [www.triquint.com](http://www.triquint.com)  
Revision C, Oct 15, 2010

**Features**

- Handset Tritium III PAD™ (PA-Duplexer) Module for UMTS Band IV
- Specified for HSUPA Modulation
- Integrates Power Amplifier, Highly Accurate Output Power Detector, Transmit Filter and Duplexer
- No Regulated Voltage Required
- Separate 'Module Enable' Pin
- All RF Ports Matched to 50 Ω
- Low Current Consumption:
  - 2 Power Modes
  - Continuous Bias in Low Power Mode
  - Low Idle Current (16mA typ.) in Low Power Mode
- Compatible for Low Collector Voltage Operation with DC-DC-Converters

**Applications**

- 3G UMTS Handsets and Data-Cards

**Package Style**

- Compact 7 x 4 x 1.1 mm<sup>3</sup> 16-Pin LGA Package

