

Applications

- GSM/GPRS Handsets and Modems
- GPRS Class 12 Compatible

Product Features

- Ultra Compact Size – 5.0x6.0x1.0mm.
- High System Efficiency – GSM850/900 48 to 47% , DCS/PCS 44 to 43%
- Integrated Power Control
- Integrated SP4T Control and pHEMT Switch
- Free choice of Rx ports for band selection
- Integrated Low Pass Tx Harmonics Filter
- Positive Supply Voltage 3.0 to 4.5 V.
- 50 Ohms Input and Output Impedances.
- CMOS Compatible Module Control Inputs.
- High-Reliability InGaP HBT Technology
- Ruggedness 20:1
- 260°C RoHS compliant

General Description

The advanced dual-band (Broadband Tx) **Transmit Module** designed for GSM850/900/DCS/PCS mobile handset applications provides full RF transmit functionality in a size of only 30 mm². The GSM850/900 and DCS/PCS power amplifier blocks including power control are combined with a low insertion loss dual-band pHEMT switch, Tx harmonics filtering, integrated switch decoder, two receive ports, and ESD protection. This architecture eliminates the need for any PA-to-switch design effort for phone designers. Both Rx ports are frequency independent and allow flexible routing to the transceiver. Fabricated in high-reliability InGaP HBT /pHEMT technology, the module supports GPRS class 12 operation and provides 50 Ohms input and output impedances at all RF input and output ports. The module control inputs are CMOS compatible and have **no need for an external reference voltage**. With excellent efficiency performance in each band, the power amplifier and switch module contributes to overall talk-time targets in next generation mobile handset designs.

Functional Block Diagram

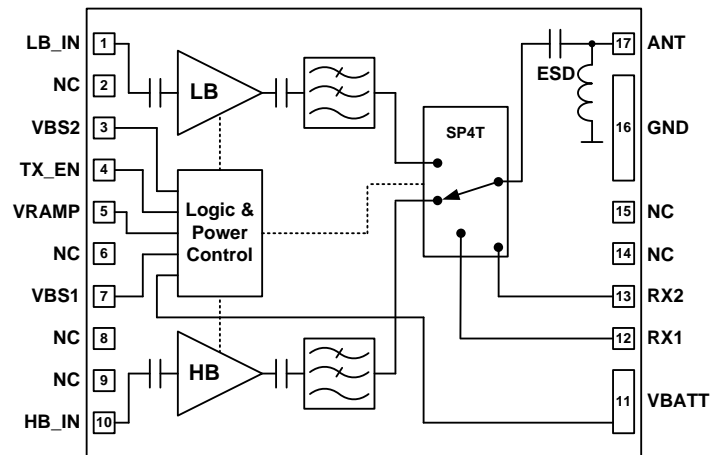

Pin Out & Assignments

Pin#	Pin Name	Function
1	LB_IN	GSM 850/900 RF Input
2	NC	Not Connected
3	V _{BS2}	Digital Control Signal
4	TX_EN	Digital Control Signal
5	V _{RAMP}	DAC Control Signal
6	NC	Not Connected
7	V _{BS1}	Digital Control Signal
8	NC	Not Connected
9	NC	Not Connected
10	HB_IN	DCS1800/PCS1900 RF Input
11	V _{BATT}	Battery Supply Voltage
12	RX1	RX1 Output
13	RX2	RX2 Output
14	NC	Not Connected
15	NC	Not Connected
16	GND	Ground
17	ANT	Antenna port
18	GND	Ground