

3V Quad-Band GSM850/GSM900/DCS/PCS Power Amplifier Module

Functional Block Diagram

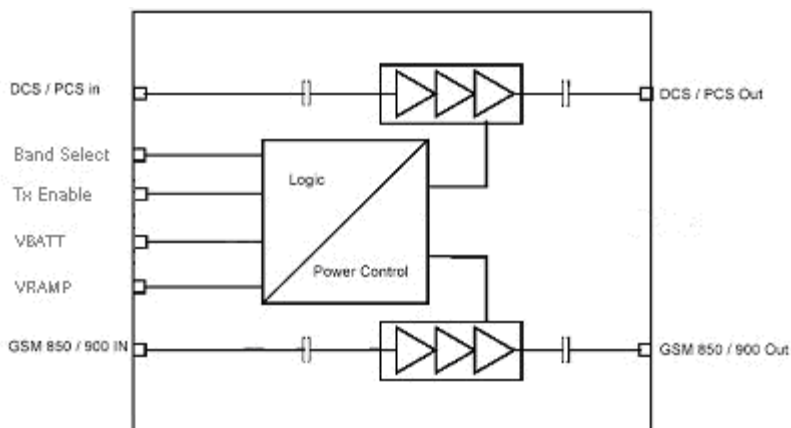

Product Description

The TQM7M5022 is a ultra-small (5x5mm), GSM/EDGE Polar PAM for handset applications. This module has been optimized for excellent EDGE efficiency, Rx band noise performance, ACPR and EVM in an open loop polar modulation environment at EDGE class E2+ operation while maintaining high GSM/GPRS efficiency.

High reliability is assured by utilizing TriQuint's 3rd generation InGaP HBT technology and by TriQuint's proven module design techniques. The low profile, ultra-small package is enabled via TriQuint's CuFlip™ technology.

Electrical Specifications

Parameter	850 Band	900 Band	DCS Band	PCS Band	Units
	Typ	Typ	Typ	Typ	
GSM Pout	35	35	33	33	dBm
Efficiency	55	55	50	50	%
Pin	6	6	6	6	dBm
EDGE Pout	29	29	28	28	dBm
Efficiency	27	27	27	27	%
Pin	6	6	6	6	dBm

Features

- Ultra-small 5x5mm form factor
- Halogen-Free, Antimony-Free
- GSM/EDGE Multi-Mode Capability
- - 87 dBm Typical Rx Noise
- - 38 dBc Typical ACPR (200KHz)
- - 66 dBc Typical ACPR (400 KHz)
- - 76 dBc Typical ACPR (600 KHz)
- 1% Typical EVM rms
- > 50 dB Typical Dynamic Range
- GPRS Class 12
- Internally Matched Input and Output
- RoHS, MSL260C pending

Applications

- GSM/EDGE/WEDGE Handsets
- GSM/EDGE/WEDGE Wireless Cards

Package Style

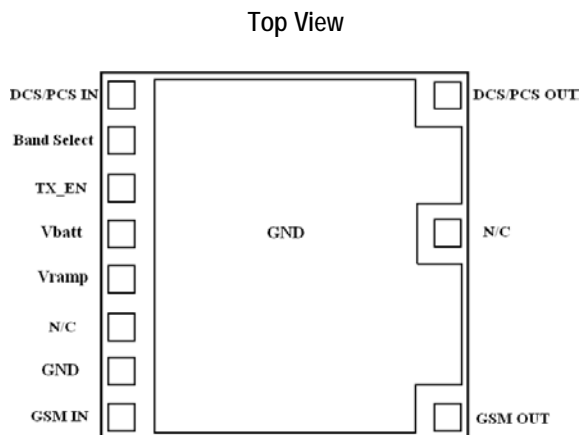

Package Size: LGA 5 x 5 x 1 mm

Data Sheet

For additional information and latest specifications, see our website: www.triquint.com
Revision E, May 13, 2011

