

TQP3M6005

Mid Band Dual LNA (1700-2000 MHz)



Applications

- Base Station receivers
- Tower-mounted amplifiers

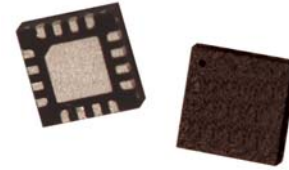

16-pin 4x4mm leadless SMT package

Product Features

- 0.36 dB Noise Figure (single channel)
- 1700-2000 MHz
- 17.9 dB Gain (single channel)
- +13.4 dBm IIP3 (single channel)
- Compact 4 x 4 mm package
- RoHS compliant, Pb-free

General Description

The TQP3M6005 is a low noise dual pHEMT discrete device operating from 1700 - 2000 MHz. Noise figure is typically 0.36 dB per channel and 0.54 dB when used in a balanced configuration with a balun.

The TQP3M6005 consists of a single monolithic GaAs die mounted in a compact 4 x 4 QFN package. This device is a dual discrete LNA intended to be used as a balanced pair in wireless networks applications. The TQP3M6005 is packaged in a Pb-free / RoHS-compliant, compact 4x4 mm surface-mount leadless package.

The TQP3M6005 is useful in a number of different applications, and is particularly well suited for cellular or WiMAX base station or tower-mounted amplifier products.

Functional Block Diagram

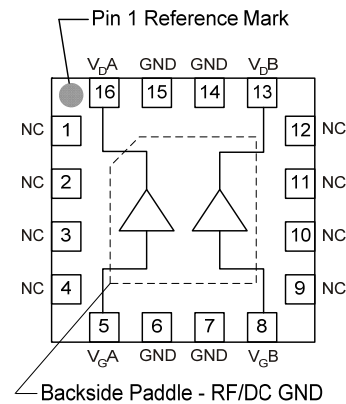

Pin Configuration

Pin #	Symbol
1, 2, 3, 4, 9, 10, 11, 12	NC (No Connect)
6, 7, 14, 15	GND (Ground)
5	V _{GA}
8	V _{GB}
13	V _{DB}
16	V _{DA}
Backside Paddle	RF/DC Ground

Ordering Information

Part No.	Description
TQP3M6005	Mid Band Dual LNA

Standard T/R size = 2500 pieces on a 7" reel.

TQP3M6005

Mid Band Dual LNA (1700-2000 MHz)



Specifications

Absolute Maximum Ratings

Parameter	Rating
Storage Temperature	-65 to 150 °C
Drain Voltage	+5 V
Gate Voltage	-1.0 to +0.5 V
Drain Current (per channel)	330 mA
Gate Current (per channel)	5 mA
RF Input Power (balanced)	+10 dBm
Power Dissipation	1.1 W
Operating Channel Temperature	150 °C
Mounting Temperature (10 seconds)	260 °C

Operation of this device outside the parameter ranges given above may cause permanent damage.

Recommended Operating Conditions

Parameter	Min	Typ	Max	Units
V_d		4.5		V
I_d (per channel)		50		mA
Operating Temp. Range	-35		+85	°C

Electrical specifications are measured at specified test conditions. Specifications are not guaranteed over all recommended operating conditions.

Electrical Specifications

Test conditions unless otherwise noted: $V_d=4.5$ V, Freq.= 1850 MHz, $I_d=50$ mA per channel, $T_A=25^\circ\text{C}$

Parameter	Conditions	Min	Typical	Max	Units
Operational Frequency Range		1700		2000	MHz
Drain Voltage ⁽¹⁾ , V_d		2	4.5	5	V
Gain dual channel ⁽²⁾		16.0	17.7		dB
Noise Figure dual channel ⁽²⁾			0.54	0.72	dB
Noise Figure per channel			0.36	0.50	dB
Reverse Isolation		20	22		dB
Output P1dB dual channel ⁽²⁾			21.6		dBm
Input IP3 dual channel ^(2,3)	F=1700 MHz	12	14		dBm
Input IP3 dual channel ^(2,3)	F=1850 MHz		15		dBm
Input IP3 per channel ⁽³⁾	F=1700 MHz		9.5		dBm
Input IP3 per channel ⁽³⁾	F=1850 MHz		13.4		dBm
Isolation between Gate 1 and Gate 2			26		dB
Isolation between Drain 1 and Drain 2			24		dB
Thermal Resistance (jnc. to case) θ_{jc}				146	°C/W

Notes:

1. V_d is set based on a 1.5 ohm resistor in the drain path. See test diagram or schematic.
2. Balanced pair, with baluns
3. Pin/tone = -13 dBm, 8 MHz tone spacing

TQP3M6005

Mid Band Dual LNA (1700-2000 MHz)



Reference Design 1700-2000 MHz

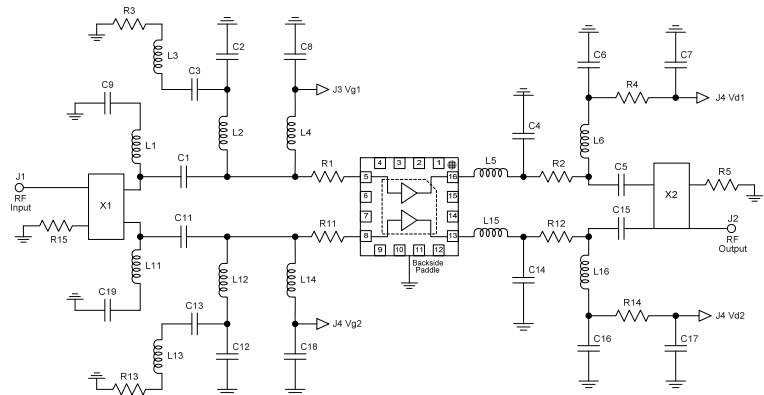
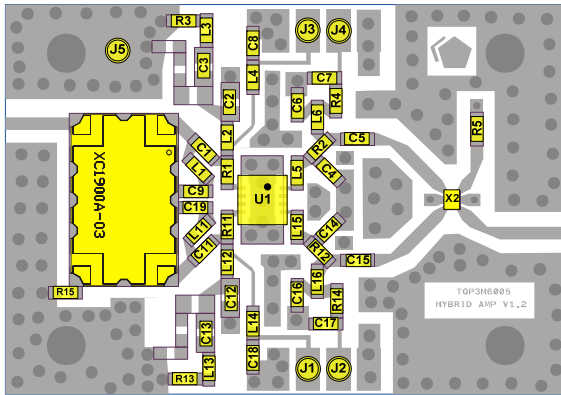

Notes:

1. See PC Board Layout, page 4 for more information.
2. Zero ohm jumpers may be replaced with copper traces in the target application layout.
3. Though not shown on reference design, grounding recommended on pins 6, 7, 14 & 15 for optimal isolation between amp A and B.

Bill of Material

Ref Des	Value	Description	Manufacturer	Part Number
U1	N/A	Mid Band Dual LNA	TriQuint	TQP3M6005
C1, C10	2.4 pF	Capacitor, 0603, +/-0.1 pF NPO	Various	
C2, C12	10 pF	Capacitor, 0603, 5%, NPO	Various	
C3, C13	22 pF	Capacitor, 0603, 5%, NPO	Various	
C4, C14	1.2 pF	Capacitor, 0603, +/-0.1 pF NPO	Various	
C5, C15	12 pF	Capacitor, 0603, 5%, NPO	Various	
C6, C16	2.2 pF	Capacitor, 0603, +/-0.1 pF NPO	Various	
C7, C17	1 uF	Capacitor, 0603, 10%, X5R	Various	
C8, C18	10 uF	Capacitor, 0603, 20%, X5R	Various	
C9, C19	0.01 uF	Capacitor, 0603, 10%, X7R	Various	
R1, R2, R11, R12	0 Ohm	Resistor, 0603, 5%, 1/16W	Various	
R3, R13	8.2 Ohm	Resistor, 0603, 5%, 1/16W	Various	
R4, R14	1.5 Ohm	Resistor, 0603, 5%, 1/16W	Various	
R5, R15	50 Ohm	Resistor, 0603, 5%, 1/16W	Various	
L1, L11	10 nH	Inductor, 0603, 5%	Coilcraft	0603CS-10NXJLW
L2, L12	3.6 nH	Inductor, 0603, 5%	Coilcraft	0603CS-3N6XJLW
L3, L13	2.2 nH	Inductor, 0603, 5%	Coilcraft	0603CS-2N2XJLW
L4, L14	33 nH	Inductor, 0603, 5%	Coilcraft	0603CS-33NXJLW
L5, L15	1.2 nH	Inductor, 0402, 5%	Coilcraft	0402CS-1N2XJLW
L6, L16	43 nH	Inductor, 0603, 5%	Coilcraft	0603CS-43NXJLW

TQP3M6005

Mid Band Dual LNA (1700-2000 MHz)



Typical Performance 1700-2000 MHz (Balanced Configuration)

Test conditions unless otherwise noted: $V_d=4.5$ V, $I_d=50$ mA per channel, $T_A=25^\circ\text{C}$

Frequency	MHz	1700	1850	2000
Gain	dB	18.7	17.7	16.8
Input Return Loss	dB	-18	-20	-18
Output Return Loss	dB	-23	-26	-38
Output P1dB	dBm	+21.5	+21.6	+21.7
Input IP3 at -13 dBm Pin/tone, 8 MHz tone spacing	dBm	+14	+15	+15.9
Noise Figure	dB	0.5	0.54	0.58

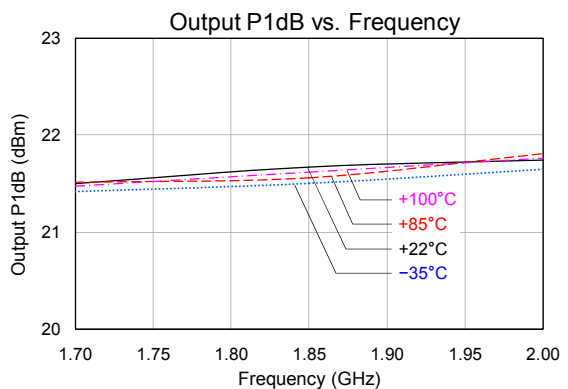
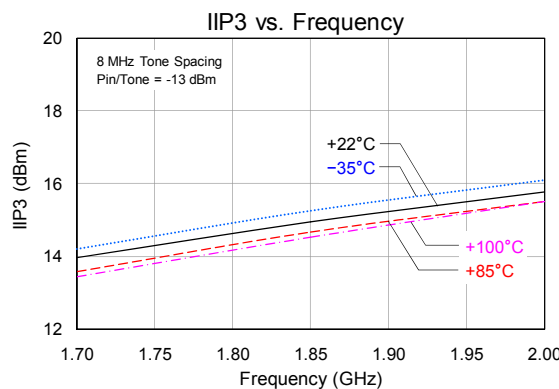
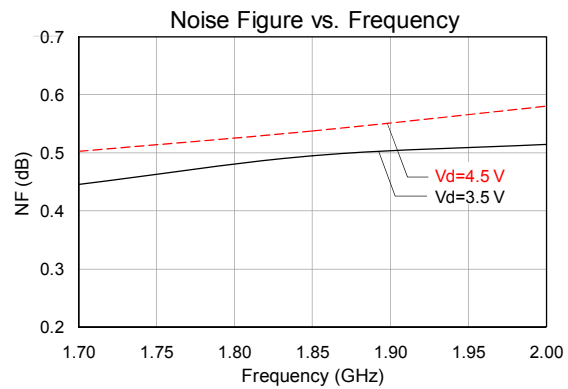
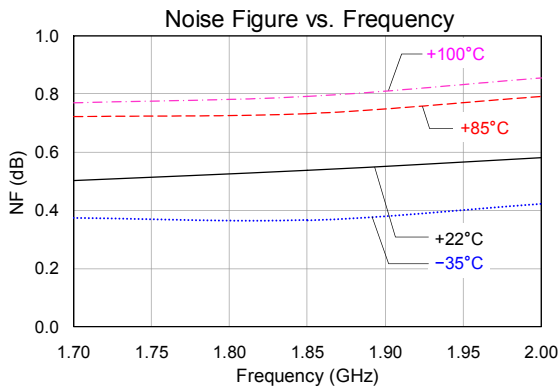
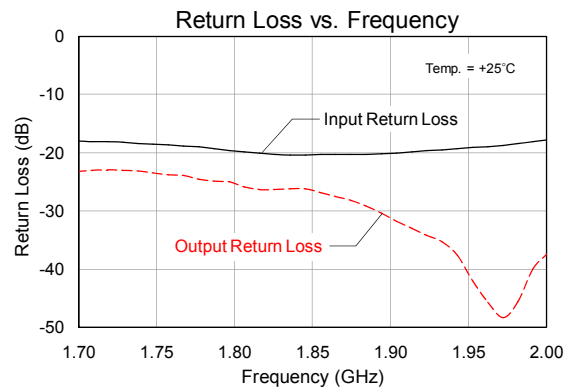
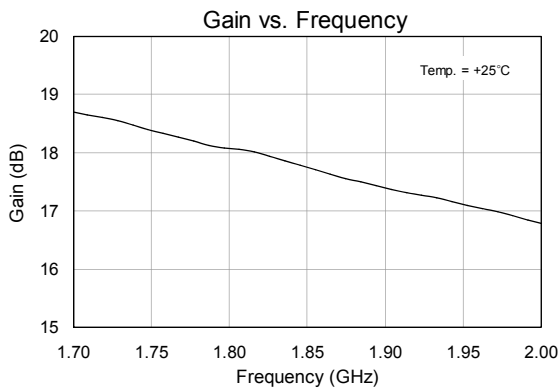

TQP3M6005

Mid Band Dual LNA (1700-2000 MHz)

Pin Description

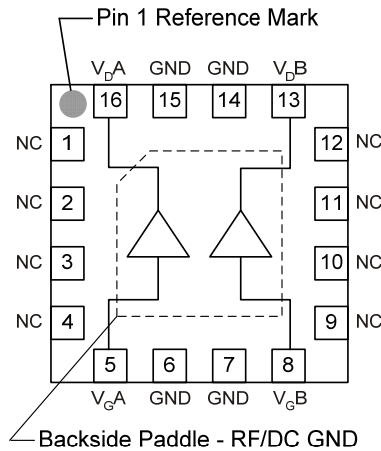

Pin #	Symbol	Description
1, 2, 3, 4, 9, 10, 11, 12	NC (No Connect)	No electrical connection. Land pads should be provided for PCB mounting integrity.
6, 7, 14, 15	GND (Ground)	Grounding recommended for optimal isolation between amp A and B
5	V _{GA}	RF Input – Channel A
8	V _{GB}	RF Input – Channel B
13	V _{DB}	RF Output – Channel B
16	V _{DA}	RF Output – Channel A
Backside Paddle	RF/DC Ground	RF/DC ground. Provide recommended via pattern and ensure good solder attach for best thermal and electrical performance.

Applications Information

PC Board Layout

PCB Material (stackup)
 Single-layer, 20 mil thick Rogers RO4350B
 2.8 mil copper top and bottom

The pad pattern shown has been developed and tested for optimized assembly at TriQuint Semiconductor. The PCB land pattern has been developed to accommodate lead and package tolerances. Since surface mount processes vary from company to company, careful process development is recommended.

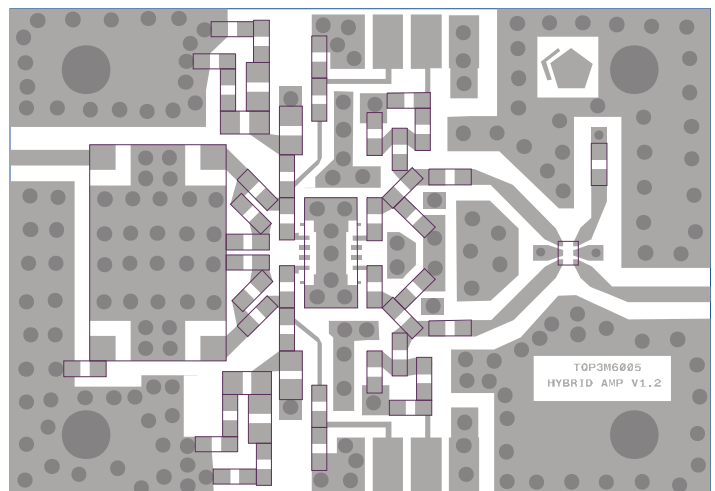

TQP3M6005

Mid Band Dual LNA (1700-2000 MHz)

Mechanical Information

Package Information and Dimensions

Material:

Lead-free/Green/RoHS-compliant.
Contact plating: ENIG

Package Marking:

Part number – 6005
Assembly code - XXXX
Year, week - YYWW

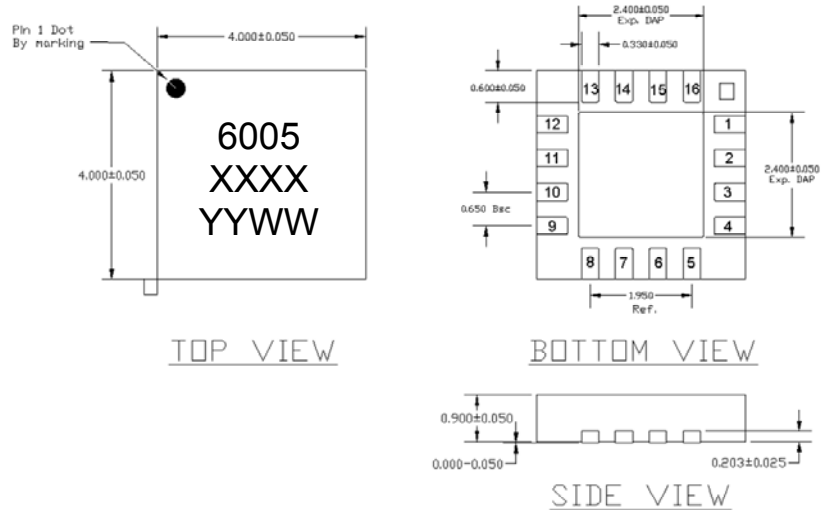

Mounting Configuration

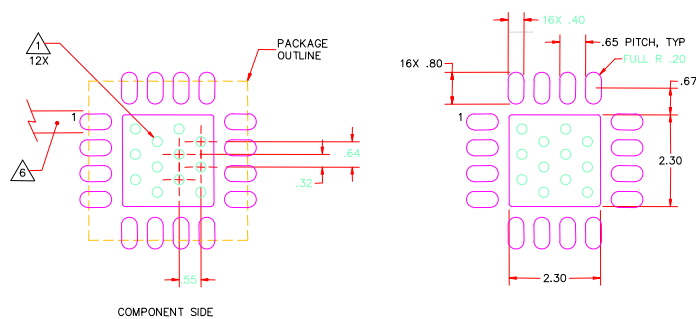

NOTES:

1. GROUND/THERMAL VIAS ARE CRITICAL FOR THE PROPER PERFORMANCE OF THIS DEVICE. VIAS SHOULD USE A .35mm (#30/.0135") DIAMETER DRILL AND HAVE A FINAL, PLATED THRU DIAMETER OF .25mm (.010").
2. ADD AS MUCH COPPER AS POSSIBLE TO INNER AND OUTER LAYERS NEAR THE PART TO ENSURE OPTIMAL THERMAL PERFORMANCE.
3. TO ENSURE RELIABLE OPERATION, DEVICE GROUND PADDLE-TO-GROUND PAD SOLDER JOINT IS CRITICAL.
4. ADD MOUNTING SCREWS NEAR THE PART TO FASTEN THE BOARD TO A HEATSINK. ENSURE THAT THE GROUND/THERMAL VIA REGION CONTACTS THE HEATSINK.
5. DO NOT PUT SOLDER MASK ON THE BACK SIDE OF THE PC BOARD IN THE REGION WHERE THE BOARD CONTACTS THE HEATSINK.
6. RF TRACE WIDTH DEPENDS UPON THE PC BOARD MATERIAL AND CONSTRUCTION.
7. USE 1 OZ. COPPER MINIMUM.
8. ALL DIMENSIONS ARE IN MILLIMETERS. ANGLES ARE IN DEGREES.

TQP3M6005

Mid Band Dual LNA (1700-2000 MHz)

Product Compliance Information

ESD Information



Caution! ESD-Sensitive Device

ESD Rating: Class 1A
Value: $\geq 250V$ to $< 500V$
Test: Human Body Model (HBM)
Standard: JEDEC Standard JESD22-A114

ESD Rating: Class III
Value: $\geq 500V$ to $< 1000V$
Test: Charged Device Model (CDM)
Standard: JEDEC Standard JESD22-C101

MSL Rating

Level 3 at +260 °C convection reflow per JEDEC standard IPC/JEDEC J-STD-020.

Solderability

Compatible with both J-STD-020 lead-free (maximum 260 °C reflow temperature) and lead (maximum 245 °C reflow temperature) soldering processes.

This part is compliant with EU 2002/95/EC RoHS directive (Restrictions on the Use of Certain Hazardous Substances in Electrical and Electronic Equipment).

This product also has the following attributes:

- Lead Free
- Halogen Free (Chlorine, Bromine)
- Antimony Free
- TBBP-A ($C_{15}H_{12}Br_4O_2$) Free
- PFOS Free
- SVHC Free

Contact Information

For the latest specifications, additional product information, worldwide sales and distribution locations, and information about TriQuint:

Web: www.triquint.com
Email: info_wireless@tqs.com

Tel: +1.503.615.9000
Fax: +1.503.615.8902

For technical questions and application information:

Email: info_wireless@tqs.com

Important Notice

The information contained herein is believed to be reliable. TriQuint makes no warranties regarding the information contained herein. TriQuint assumes no responsibility or liability whatsoever for any of the information contained herein. TriQuint assumes no responsibility or liability whatsoever for the use of the information contained herein. The information contained herein is provided "AS IS, WHERE IS" and with all faults, and the entire risk associated with such information is entirely with the user. All information contained herein is subject to change without notice. Customers should obtain and verify the latest relevant information before placing orders for TriQuint products. The information contained herein or any use of such information does not grant, explicitly or implicitly, to any party any patent rights, licenses, or any other intellectual property rights, whether with regard to such information itself or anything described by such information.

TriQuint products are not warranted or authorized for use as critical components in medical, life-saving, or life-sustaining applications, or other applications where a failure would reasonably be expected to cause severe personal injury or death.