

**SP4T High Power GSM-EDGE Antenna Switch With Decoder**

**Functional Block Diagram**

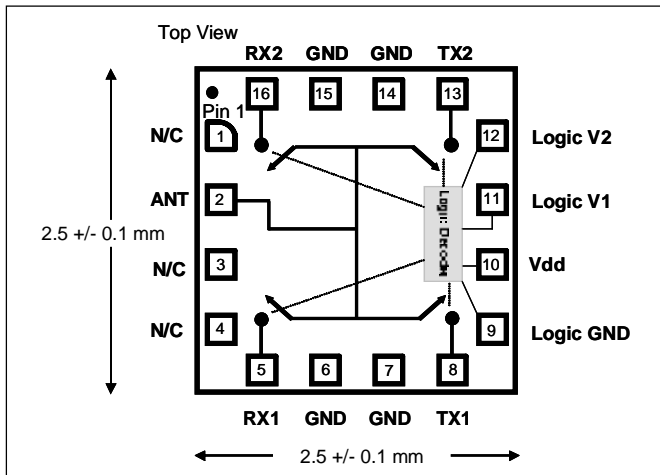

**Product Description**

TriQuint's TQP4M4010 is a high power antenna switch in a single pole four throw (SP4T) configuration. The die utilizes TriQuint's E/D-PHEMT MMIC switch process to provide optimized harmonic performance with built-in 2-line logic decoder for use in GSM-EDGE applications. PHEMT Switches are a very low DC current replacement for classic PIN diode based switches. This product is ideally suited to applications where the antenna of a GSM-EDGE handset is to be routed to the Rx or Tx path, requiring only 2 logic control lines. The Small Low Integrated Molded (SLIM) package is ideal for height critical applications. The design is asymmetric between Tx and Rx paths. Each path is broadband allowing the user to assign GSM850/900 or DCS/PCS to either of the Tx or Rx ports as desired.

**Electrical Specifications<sup>1</sup>**

Parameter	Min	Typ	Max	Units
GSM850/900 Tx Insertion Loss		0.54	0.65	dB
DCS/PCS Tx Insertion Loss		0.63	0.75	dB
GSM850/900 Rx Insertion Loss		0.49	0.65	dB
DCS/PCS Rx Insertion Loss		0.60	0.80	dB
Rx to Rx Isolation, Rx on	30	33		dB
Tx to Rx Isolation, Tx on	30	32		dB
Tx to Tx isolation, Tx on	30	34		dB
Return Loss	18	25		dB

Note 1: Test Conditions  $Z_0 = 50 \text{ ohms}$ ;  $V_{dd} = +2.7V$ ;  $T_c = 25^\circ C$ .

**Features**

- pHEMT GaAs MMIC Die
- Integrated Logic Decoder with 2 Control Lines
- Excellent Harmonic Performance  
2H: -78 dBc Typ @ GSM850/900, +35 dBm  
2H: -75 dBc @ DCS/PCS, +33 dBm  
3H: -72 dBc Typ @ GSM850/900, +35 dBm  
3H: -73 dBc @ DCS/PCS, +33 dBm
- Excellent ESD Rating:  
250V HBM, 750V CDM
- Low Control Decoder Current:  
110  $\mu A$  typ at  $V_{dd} = +2.7V$  under TX RF Drive  
75  $\mu A$  typ at  $V_{dd} = +2.7V$  in Rx state
- High Isolation: 33dB typ
- SLIM-17 Package
- Small Footprint 2.5 x 2.5 mm
- Very Low Profile: 0.6mm max height

**Applications**

- GSM-EDGE Antenna Switch Modules (ASM) and Front-End Modules (FEM).

**Package Style**

SLIM-17 2.5 x 2.5 x 0.6mm Package:



## SP4T High Power GSM-EDGE Antenna Switch With Decoder

### Absolute Maximum Ratings

Symbol	Parameter	Absolute Maximum Value	Units
P <sub>IN Max</sub>	Maximum Input Power	+37	dBm
V <sub>dd</sub>	Supply Voltage	-0.5 to +6.0	V
T <sub>c</sub>	Case Temperature, Survival	-40 to +85	°C
T <sub>STG</sub>	Storage Temperature	-40 to +150	°C

Note: The part may not survive all maximums applied simultaneously.

### Electrical Characteristics<sup>1,2</sup>

Parameter	Test Conditions	Units	Min	Typ	Max
Tx Insertion Loss	GSM850/900	dB		0.54	0.65
Tx Insertion Loss	DCS/PCS	dB		0.63	0.75
Rx Insertion Loss	GSM850/900	dB		0.49	0.65
Rx Insertion Loss	DCS/PCS	dB		0.60	0.80
Rx to Rx Isolation	All bands, RX1 or RX2 on.	dB	30	33	
Tx to Rx Isolation	All bands, TX1 or TX2 on.	dB	30	32	
Tx to Tx isolation	All bands, TX1 or TX2 on.	dB	30	34	
Return Loss	All bands	dB	18	25	
P0.1dB	TX1 or TX2 path, GSM850/900	dBm	36.5	38	
P0.1dB	TX1 or TX2 path, DCS/PCS	dBm	36.5	38	
2 <sup>nd</sup> Harmonic	GSM850/900; @ +35 dBm input	dBc	-70	-78	
2 <sup>nd</sup> Harmonic	DCS/PCS; @ +33 dBm input	dBc	-70	-75	
3 <sup>rd</sup> Harmonic	GSM850/900; @ +35 dBm input	dBc	-70	-72	
3 <sup>rd</sup> Harmonic	DCS/PCS; @ +33 dBm input	dBc	-70	-73	
V <sub>dd</sub> Logic Supply Current	TX1 or TX2 on, under Tx drive power +35dBm GSM850/900 or +33dBm DCS/PCS, V <sub>dd</sub> = +2.7V	μA		110	170
V <sub>dd</sub> Logic Supply Current	All paths, no Tx drive power in TX1 or TX2 path, V <sub>dd</sub> = +2.7V	μA		75	110
Trise, Tfall	10% to 90% RF, 90% to 10% RF	μS			1
Ton, Toff	50% control to 90% RF, and 50% control to 10% RF	μS			1

**Note 1:** External DC Blocking capacitors are required at all RF ports.

**Note 2:** Test Conditions Z<sub>0</sub> = 50 ohms; V<sub>dd</sub> = +2.7V, T<sub>c</sub> = 25°C.

**SP4T High Power GSM-EDGE Antenna Switch With Decoder**

*Application Examples*

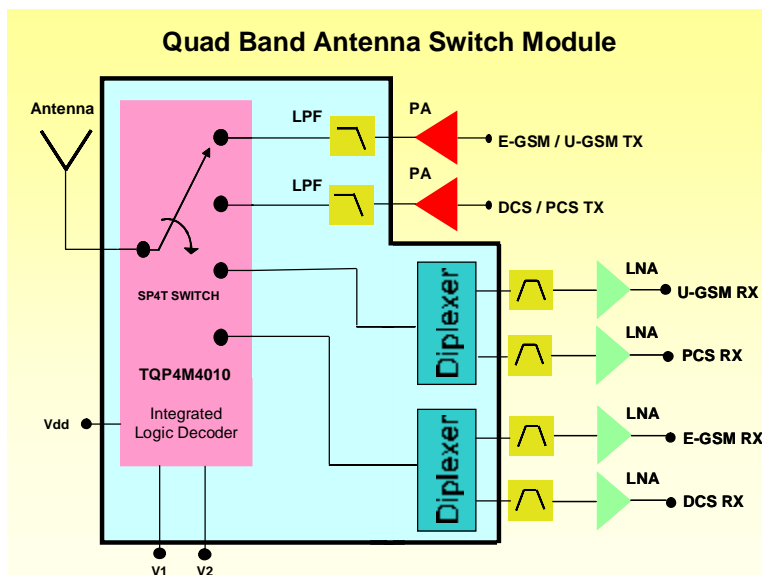
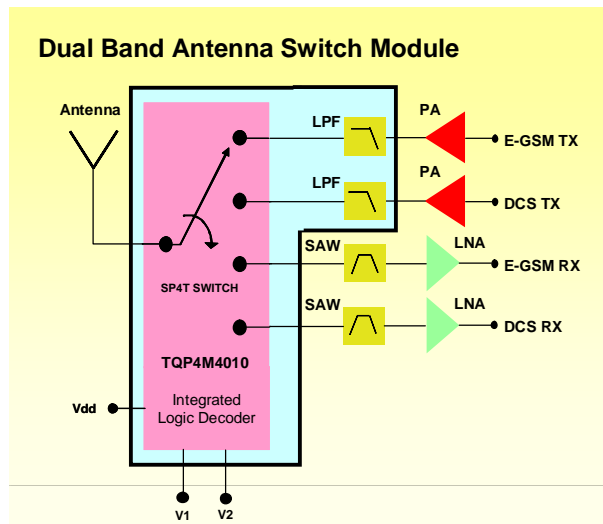

**SP4T High Power GSM-EDGE Antenna Switch With Decoder**

**Truth Table 1,2,3,4.**

V1	V2	ANT-RX1	ANT-RX2	ANT-TX1	ANT-TX2
0	0	On	Off	Off	Off
0	1	Off	On	Off	Off
1	0	Off	Off	On	Off
1	1	Off	Off	Off	On

Note 1: Logic Supply Vdd = +2.7V nominal; operating Limits Vdd = +2.5V to +5.0V  
 Note 2: Logic High State V1, V2 = 2.5V nominal; operating limits +1.75V to +5.0V  
 Note 3: Logic Low State V1, V2 = 0.2V nominal; operating limits 0V to +0.75V  
 Note 4: Vdd must be turned on and V1, V2 in the TX state before applying Tx power; Tx power should be off before removing Vdd.

**Pin Descriptions:**

Pad Number	Pad Name	Description
1	N/C	No Connection
2	ANT	ANTENNA
3	N/C	No Connection
4	N/C	No Connection
5	RX1	RX Port 1
6	GND	Ground
7	GND	Ground
8	TX1	TX port 1
9	Logic GND	Logic Ground
10	Vdd	Decoder Supply
11	V1	Logic Bit V1 Input
12	V2	Logic Bit V1 Input
13	TX2	TX Port 2
14	GND	Ground
15	GND	Ground
16	RX2	RX Port 2

**Typical Performance** Test Conditions (Unless Otherwise Specified): Zo = 50 ohms: Vdd = 2.7V, Tc=25°C

**Insertion Loss and Match**

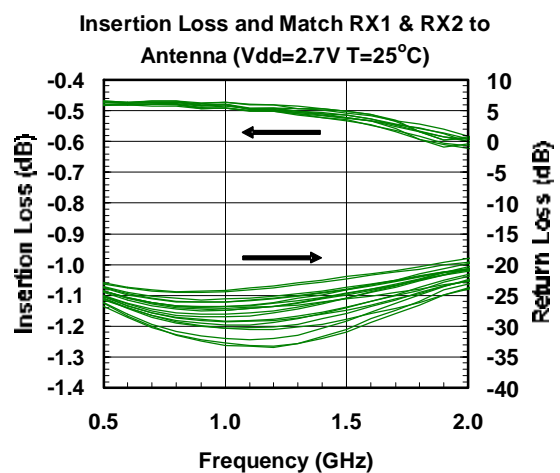
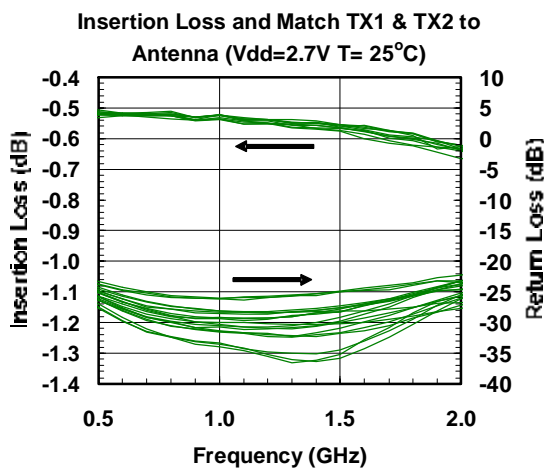

**SP4T High Power GSM-EDGE Antenna Switch With Decoder**

*Isolation*

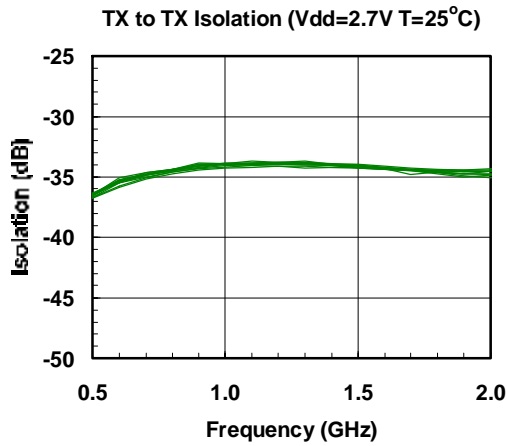
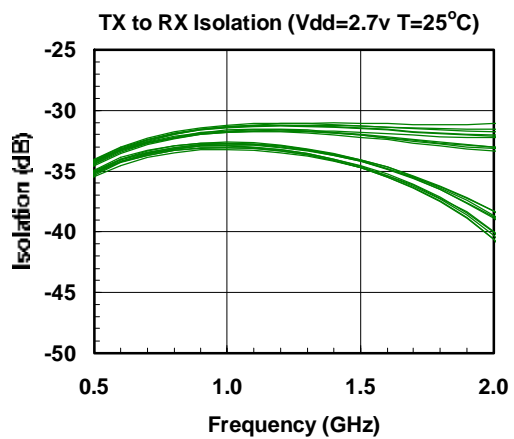
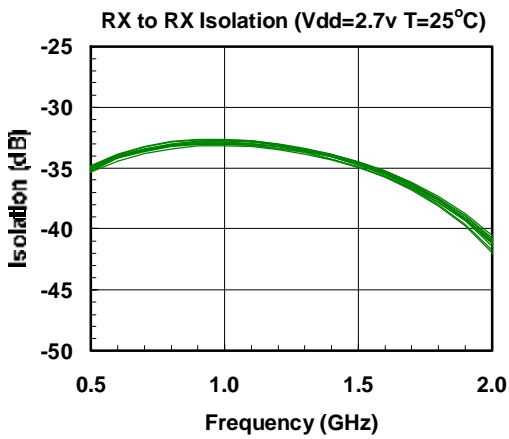

**SP4T High Power GSM-EDGE Antenna Switch With Decoder**

*Harmonics*

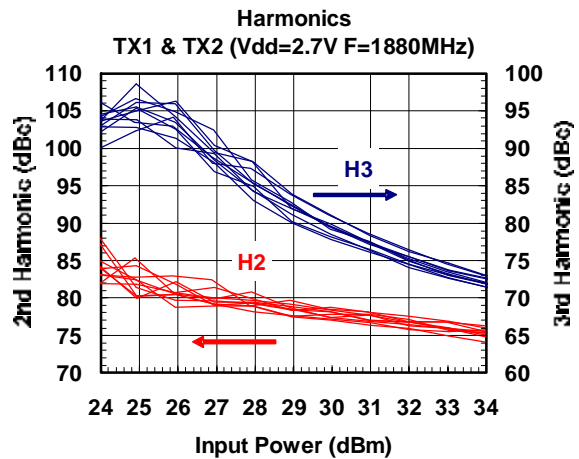
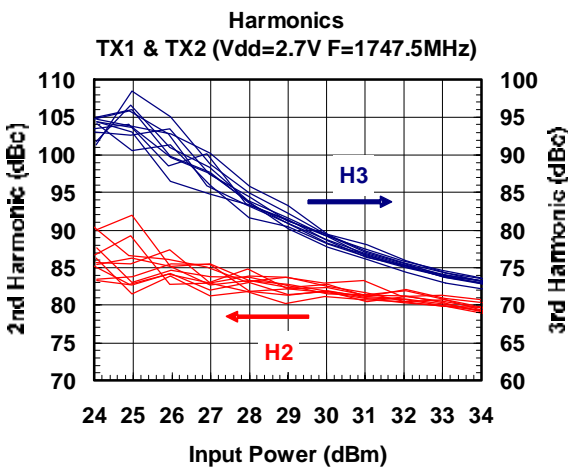
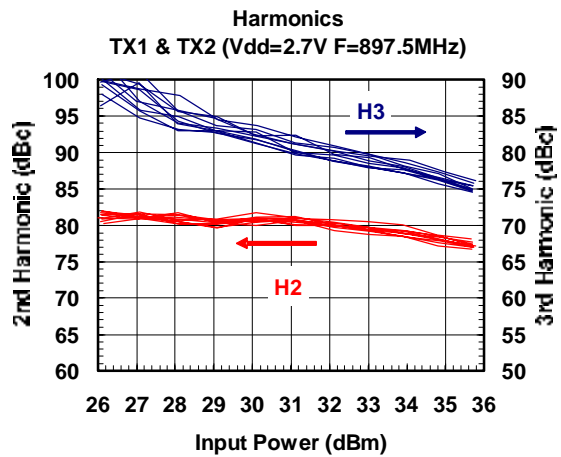
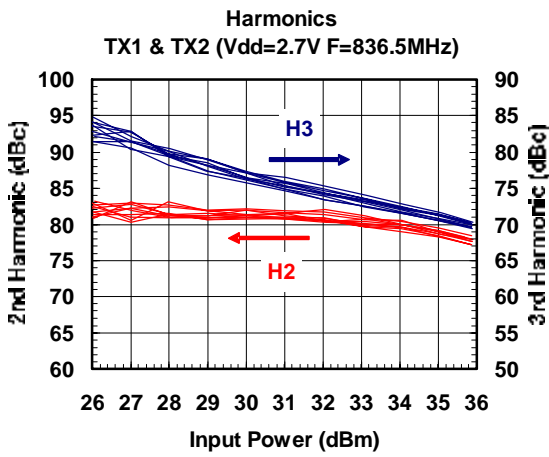

**SP4T High Power GSM-EDGE Antenna Switch With Decoder**

*Decoder Current*

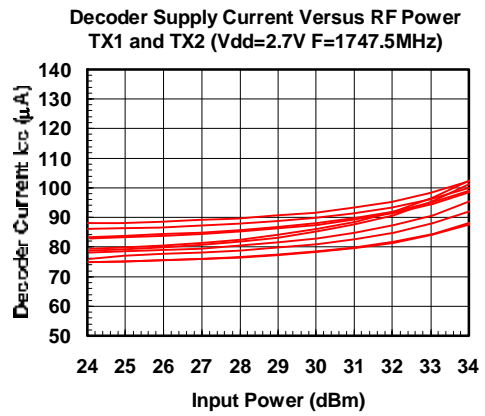
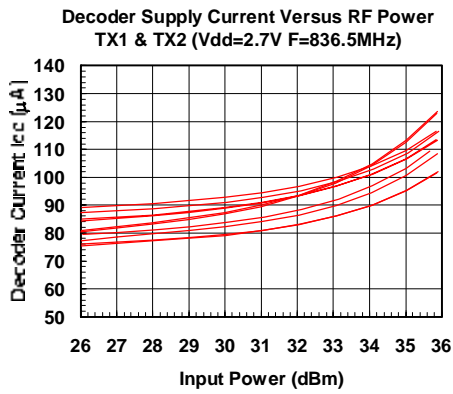

*Typical Test Circuit*

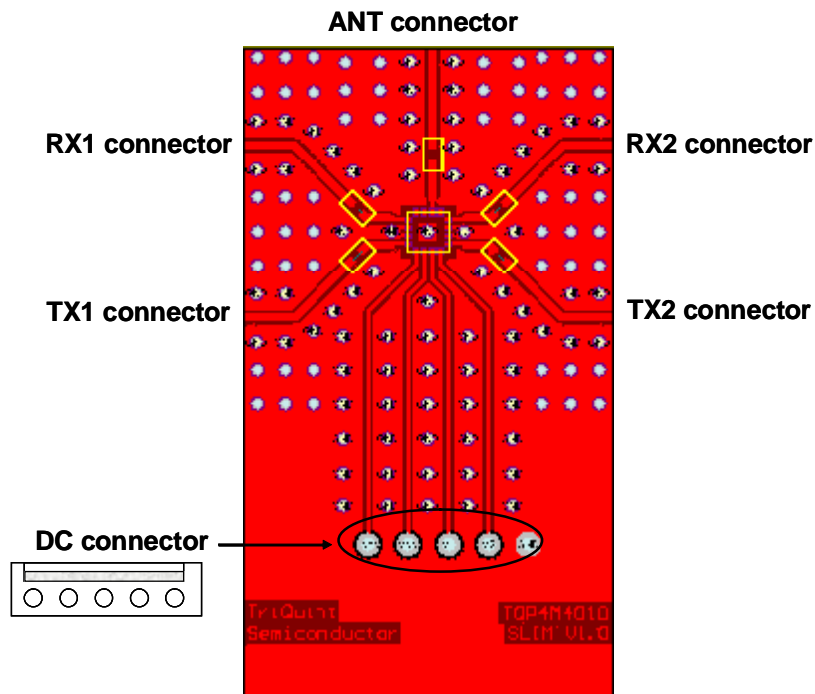

**SP4T High Power GSM-EDGE Antenna Switch With Decoder**

**Application Board Capacitors and Locations:**

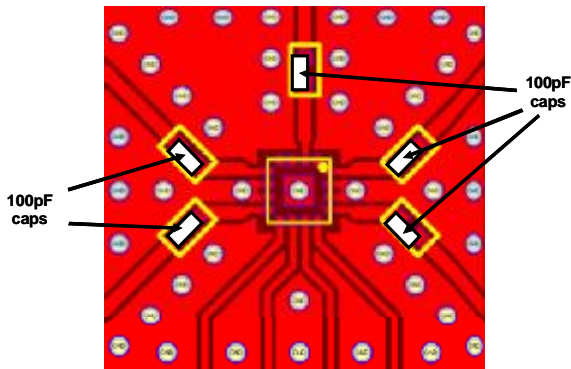

**Package Configuration on Board:**

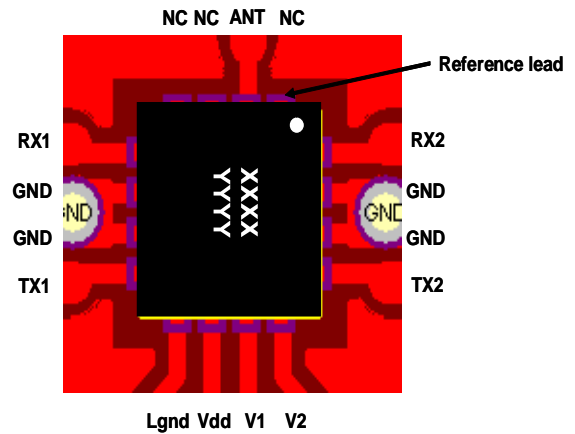

Signal Frequency RF Decoupling Capacitor is built into the switch die on the Vdd line. External low frequency decoupling capacitors can be added externally on the Vdd, V1, and V2 lines if required.

**Applications information; tuning procedures; board layout precautions**

**Recommended PCB Footprint:**

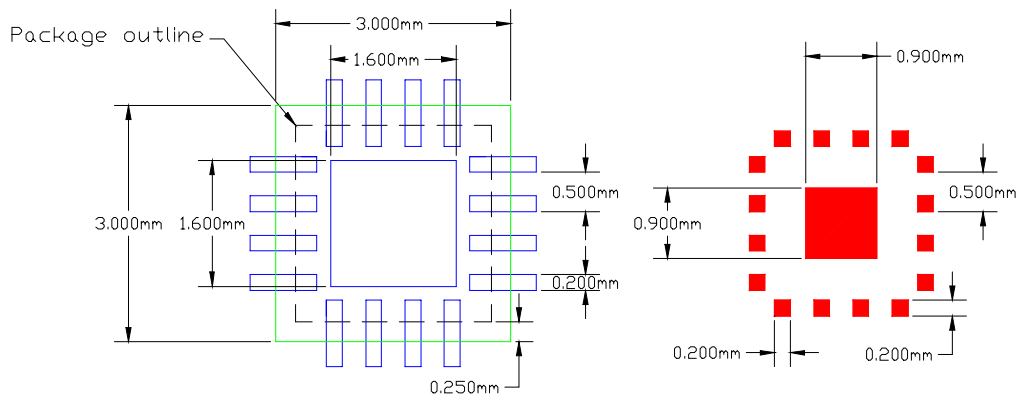

**PCB Layout:**

Leads are to extend away from the pads – these should be the same shape and size to ensure equal solder coverage.

Center pad is to be the same size as the package center pad.

**Solder mask:**

The solder mask opening should be offset from the package edges by 250um.

**Solder stencil:**

Solder stencil openings for pads are to be same size as package pads.

Center pad opening is about 30% of PCB pad size.

■ PCB

■ Solder mask opening

■ Solder stencil apertures



**SP4T High Power GSM-EDGE Antenna Switch With Decoder**

**Application Board Loss De-Embedding Curve:**

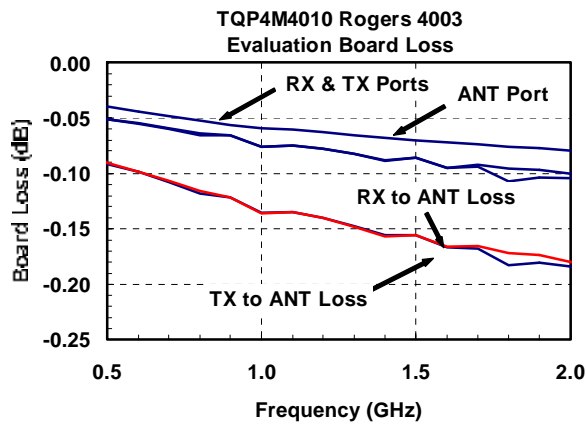

**Part Marking Information:**

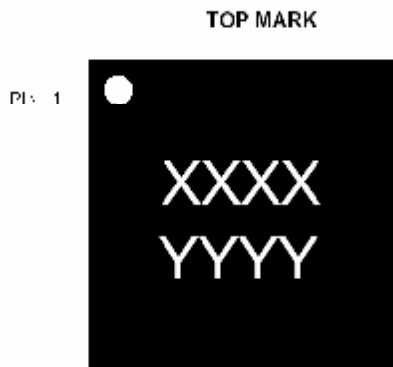

WHITE INK OR LASER MARK .

Line 1: XXXX-Last 4 digits of TQ5 lot number

Line 2: YYYY- 4 digit date code

**SP4T High Power GSM-EDGE Antenna Switch With Decoder**

**Tape and Reel Information:**

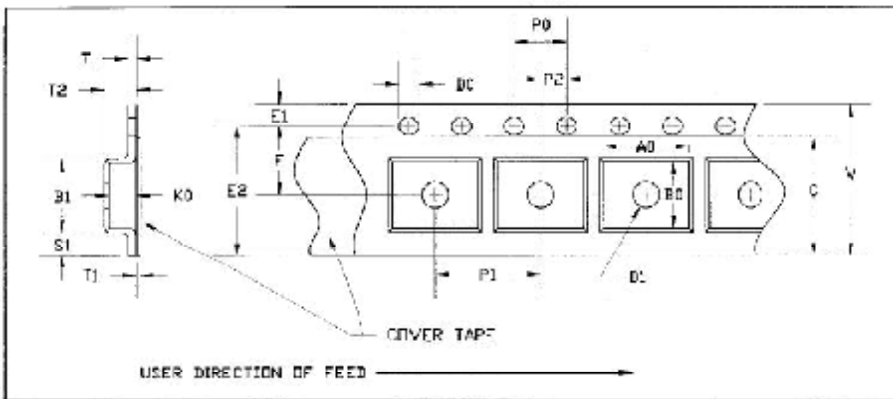

**FIXED CARRIER AND COVER TAPE DIMENSIONS**

PART	FEATURE	SYMBOL	SIZE (in)	SIZE (mm)
CAVITY	BOTTOM HOLE DIAMETER	D1	0.059	1.50
PERFORATION	DIAMETER	D0	0.059	1.50
	PITCH	P0	0.157	4.00
	POSITION	E1	0.069	1.75
CARRIER TAPE	THICKNESS	T	0.012	0.30
COVER TAPE	THICKNESS	T1	0.002	0.056

**SLIM-17 CARRIER AND COVER TAPE DIMENSIONS**

PART	FEATURE	SYMBOL	SIZE (in)	SIZE (mm)
CAVITY	LENGTH	A0	0.107	2.73
	WIDTH	B0	0.107	2.73
	DEPTH	K0	0.031	0.80
	PITCH	P1	0.157	4.00
DISTANCE BETWEEN CENTERLINE	CAVITY TO PERFORATION LENGTH DIRECTION	P2	0.079	2.00
	CAVITY TO PERFORATION WIDTH DIRECTION	F	0.138	3.50
COVER TAPE	WIDTH	C	0.213	5.40
CARRIER TAPE	WIDTH	W	0.315	8.00

**SP4T High Power GSM-EDGE Antenna Switch With Decoder**

**Packaging and Ordering Information**

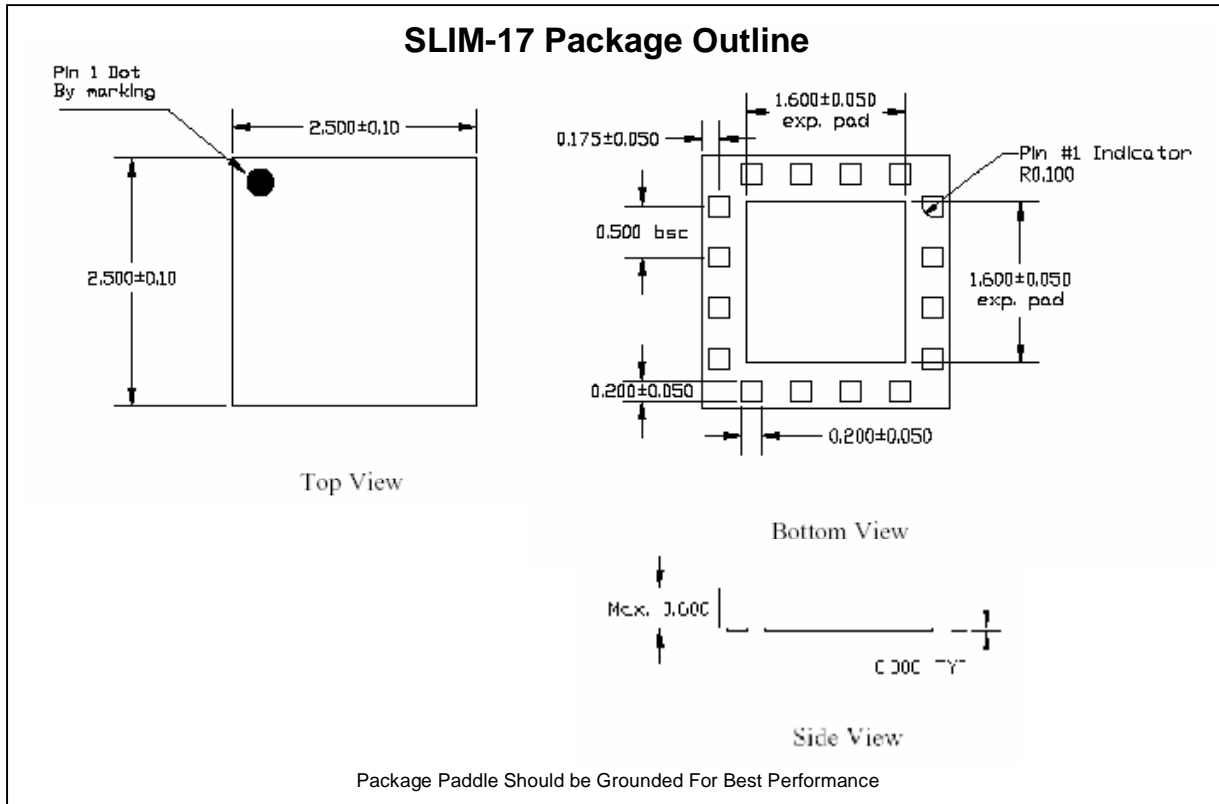

**Additional Information**<sup>1</sup>

<sup>1</sup> For latest specifications, additional product information, worldwide sales and distribution locations, and information about TriQuint:

Web: [www.triquint.com](http://www.triquint.com) Tel: (503) 615-9000  
 Email: [info\\_wireless@tqs.com](mailto:info_wireless@tqs.com) Fax: (503) 615-8902

For technical questions and additional information on specific applications:

Email: [info\\_wireless@tqs.com](mailto:info_wireless@tqs.com)

The information provided herein is believed to be reliable; TriQuint assumes no liability for inaccuracies or omissions. TriQuint assumes no responsibility for the use of this information, and all such information shall be entirely at the user's own risk. Prices and specifications are subject to change without notice. No patent rights or licenses to any of the circuits described herein are implied or granted to any third party.

TriQuint does not authorize or warrant any TriQuint product for use in life-support devices and/or systems.

Copyright © 2005 TriQuint Semiconductor, Inc. All rights reserved.