

TQP4M9083

High Linearity 7-Bit, 31.75dB Digital Step Attenuator



Applications

- Mobile Infrastructure
- LTE / WCDMA / CDMA / EDGE
- Test Equipment and Sensors
- IF and RF Applications
- General Purpose Wireless

Product Features

- 0.4 – 3.5 GHz
- 0.25 dB LSB Steps to 31.75 dB
- +55 dBm Input IP3
- 1.7 dB Insertion Loss @ 2.5 GHz
- CMOS compatible Serial Control Interface
- Max attenuation state at initial power up
- 50 Ω Impedance
- +5V Supply Voltage

General Description

The TQP4M9083 is a high linearity, low insertion loss, 7-bit, 31.75 dB Digital Step Attenuator (DSA) operating over the 0.4–3.5GHz frequency range. The digital step attenuator uses a single positive 5V supply and has a serial periphery interface (SPI™) for changing attenuation states. This product maintains high attenuation accuracy over frequency and temperature. No external matching components are needed for the DSA.

The TQP4M9083 is available in a standard lead-free /green/RoHS-compliant 24-pin 4x4mm QFN package. The TQP4M9071 and TQP4M9072 are also available from TriQuint as a footprint and pin compatible 6-bit, 31.5dB DSA with a parallel control interface and serial control interface respectively.

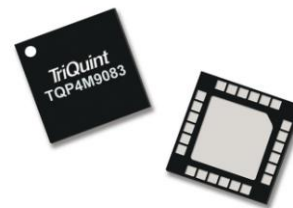

24-pin 4x4mm leadless QFN package

Functional Block Diagram

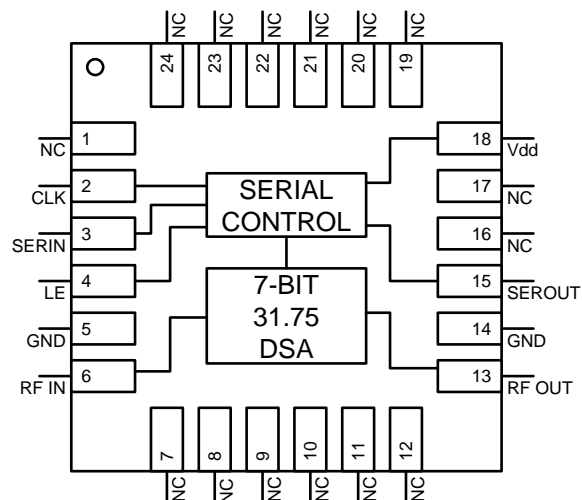

Pin Configuration

Pin #	Symbol
2	CLK
3	SERIN
4	LE
6	RF IN
13	RF OUT
15	SEROUT
18	Vdd
5, 14	GND
Backside Paddle	Ground

All other pins are N/C

Ordering Information

Part No.	Description
TQP4M9083	7-Bit, 31.75 dB DSA
TQP4M9083-PCB	0.4-3.5GHz Evaluation Board

PCB includes USB control interface board, EVH.

Standard T/R size = 2500 pieces on a 13" reel.

TQP4M9083

High Linearity 7-Bit, 31.75dB Digital Step Attenuator



Specifications

Absolute Maximum Ratings

Parameter	Rating
Storage Temperature	-55 to 150 °C
Junction Temperature	150 °C
RF Input Power, 50Ω, T = 85°C	+28 dBm
V _{dd} , Power Supply Voltage	+6.0 V
Digital Input Voltage	V _{dd} + 0.5V

Operation of this device outside the parameter ranges given above may cause permanent damage.

Recommended Operating Conditions

Parameter	Min	yp	Max	Units
V _{dd}	4.75	5	5.25	V
T (case)	-40		85	°C

Electrical specifications are measured at specified test conditions. Specifications are not guaranteed over all recommended operating conditions.

Electrical Specifications

Test conditions: 25°C, V_{dd} = +5V, 50Ω system

Parameter	Conditions	Min	Typical	Max	Units
Operational Frequency Range		400		3500	MHz
Insertion Loss	1.0 GHz		1.1		dB
	2.0 GHz		1.5		dB
	2.5 GHz		1.7	2.3	dB
	3.0 GHz		2.0		dB
Return Loss	All States		17		dB
Accuracy Error	0.4-3.5 GHz, 0.25dB State	0.25 ±0.15			dB
	0.4-3.0 GHz, 0.5dB – 31.75dB State	± (0.3 + 3% of Atten. Setting) Max			dB
	3.0-3.5 GHz, 0.5dB – 31.75dB State	± (0.4 + 4% of Atten. Setting) Max			dB
Input IP3	Input = +15dBm / tone, All States		+55		dBm
Input P0.1dB	All States		+30		dBm
Time _{rise / fall}	10% / 90% RF		90		ns
Time _{On} , Time _{Off}	50% CTL to 10% / 90% RF		118		ns
Supply Voltage, V _{dd}			+5		V
Supply Current, I _{dd}			2.0		mA

TQP4M9083

High Linearity 7-Bit, 31.75dB Digital Step Attenuator



Serial Control Interface

The TQP4M9083 has a CMOS SPI™ input compatible serial interface. The input is 3-wire: Clock (CLK), Latch Enable (LE) and Serial Input (SERIN). At power up, the serial control interface resets device attenuation state to 31.75dB. The 7-bit SERIN word is loaded into the register on rising edge of the CLK, MSB first. Serial Output (SEROUT) is propagated on rising clock edge through an internal 7-bit register. MSB, the first data to be loaded on SERIN, will appear on SEROUT after the 7th rising clock edge cycle.

When LE is high, CLK is internally disabled.

SERIN (MSB in First 7-Bit Word) Control Logic Truth Table

7-Bit Control Word to DSA							Attenuation State	
MSB	D6	D5	D4	D3	D2	LSB		
	D6	D5	D4	D3	D2	D1	D0	
	1	1	1	1	1	1	1	Reference : IL
	1	1	1	1	1	1	0	0.25 dB
	1	1	1	1	1	0	1	0.5 dB
	1	1	1	1	0	1	1	1 dB
	1	1	1	0	1	1	1	2 dB
	1	1	0	1	1	1	1	4 dB
	1	0	1	1	1	1	1	8 dB
	0	1	1	1	1	1	1	16 dB
	0	0	0	0	0	0	0	31.75 dB

Any combination of the possible 128 states will provide an attenuation of approximately the sum of bits selected

Serial Control Interface Timing Diagram

CLK is disabled when LE is high

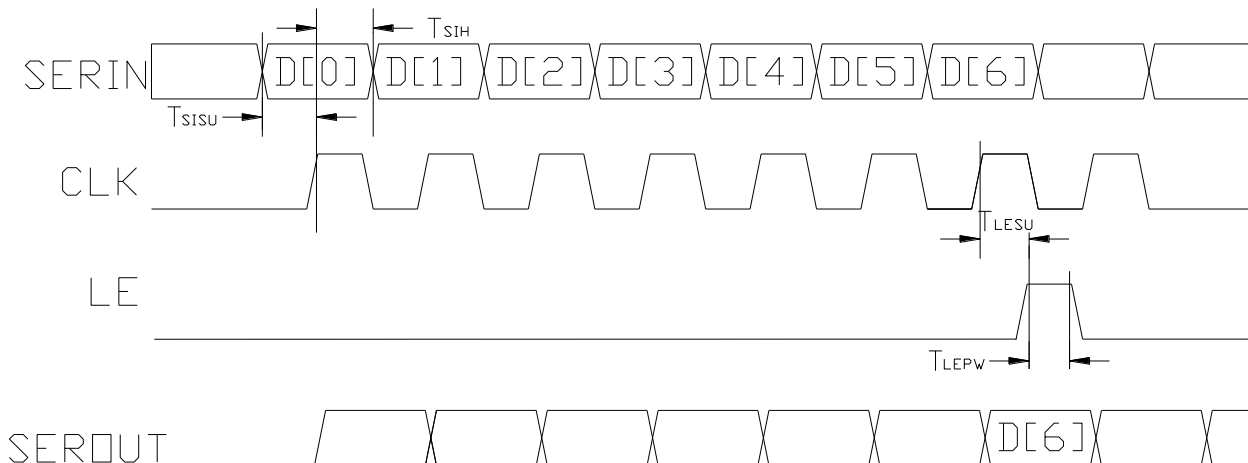

TQP4M9083

High Linearity 7-Bit, 31.75dB Digital Step Attenuator



Serial Control Timing Characteristics

Test conditions: 25°C, $V_{dd} = +5V$

Parameter	Condition	Min	Max	Units
Clock Frequency	50% Duty Cycle		10	MHz
LE Setup Time, t_{LESU}	after last CLK rising edge	10		ns
LE Pulse Width, t_{LEPW}		30		ns
SERIN set-up time, t_{SISU}	before CLK rising edge	10		ns
SERIN hold-time, t_{SIH}	after CLK rising edge	10		ns
LE Pulse Spacing t_{LE}	LE to LE pulse spacing	730		ns

Serial Control DC Logic Characteristics

Test conditions: 25°C, $V_{dd} = +5V$

Parameter	Condition	Min	Max	Units
Input Low Voltage, V_{IL}		0	0.8	V
Input High Voltage, V_{IH}		2.3	V_{dd}	V
Output High Voltage, V_{OHmin}	On SEROUT	2.0	V_{dd}	V
Output Low Voltage, V_{OLmax}	On SEROUT	0	0.8	V
Input Current, I_{IH} / I_{IL}	On SERIN, LE and CLK	-10	+10	μA

TQP4M9083

High Linearity 7-Bit, 31.75dB Digital Step Attenuator



Typical Performance Data

Performance plots data is measured using Bias Tee on RF ports.

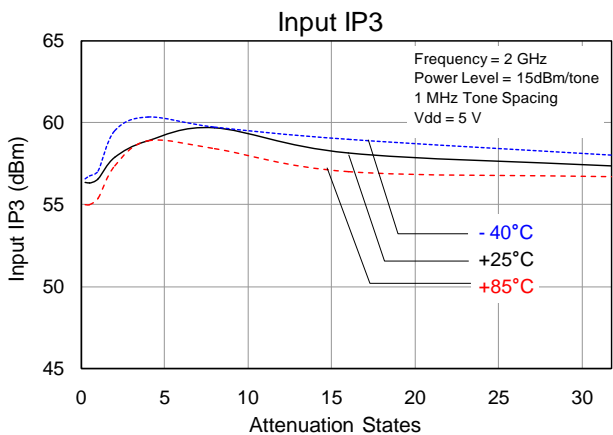
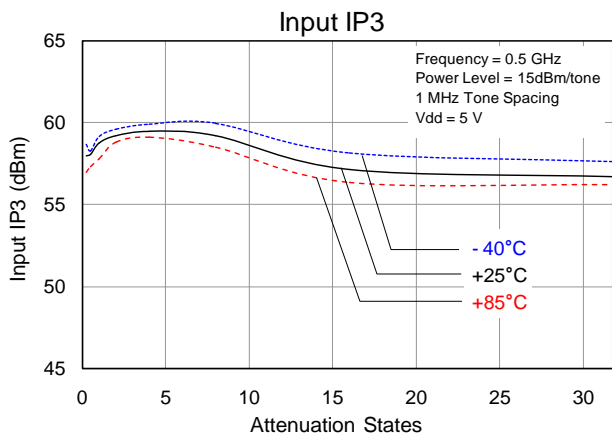
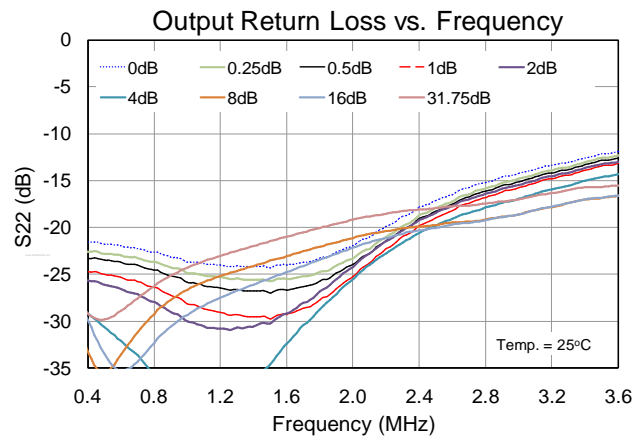
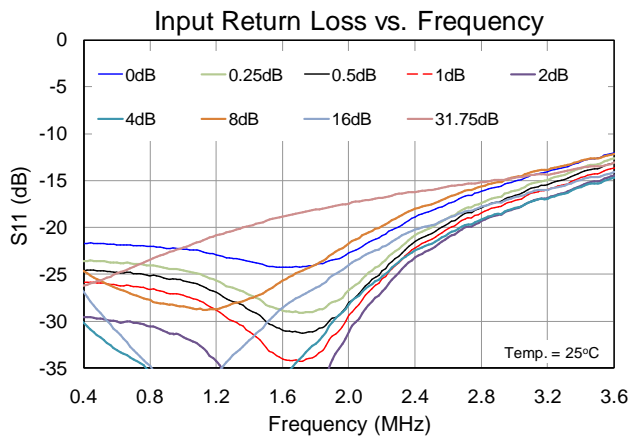
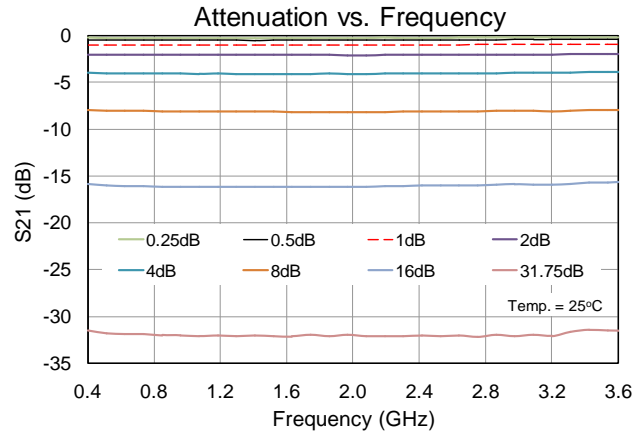
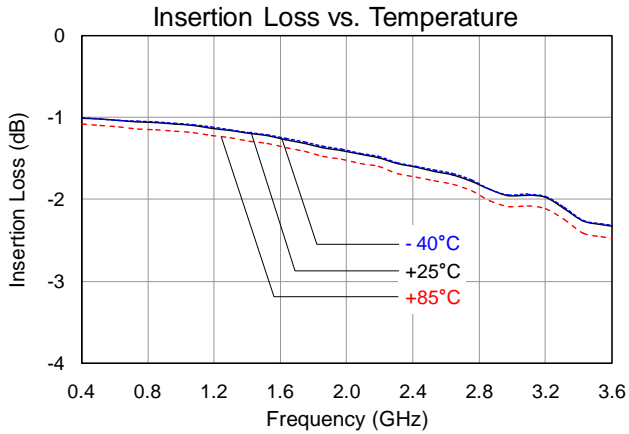

TQP4M9083

High Linearity 7-Bit, 31.75dB Digital Step Attenuator



Typical Performance Data

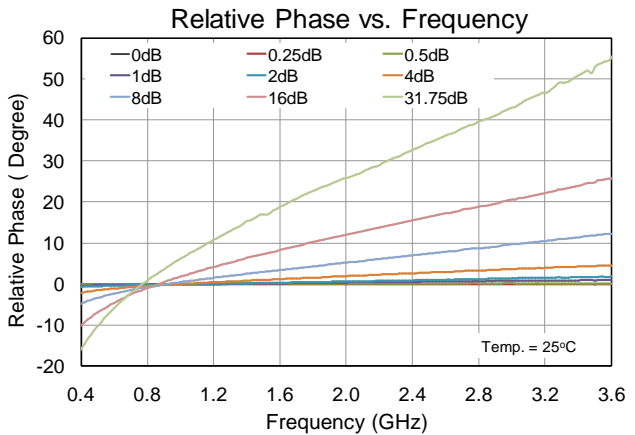
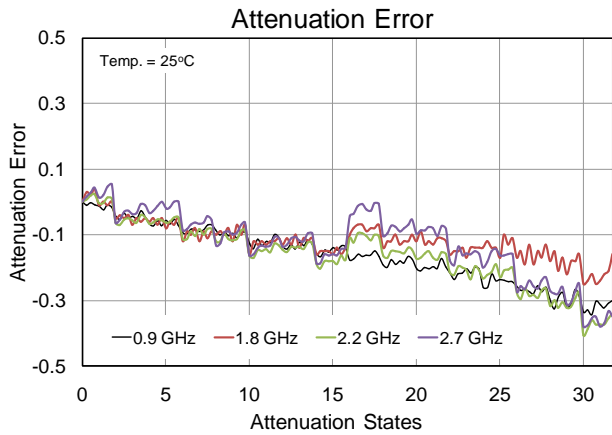

Detailed Device Description

The TQP4M9083 is a high linearity, low insertion loss, wideband, 7-bit, 31.75 dB digital step attenuator. The digital step attenuator uses a single 5V supply and has a CMOS SPI™ controller. This product maintains high attenuation accuracy over frequency and temperature.

Further assistance may be requested from TriQuint Applications Engineering, sjapplications.engineering@tqs.com.

Functional Schematic Diagram

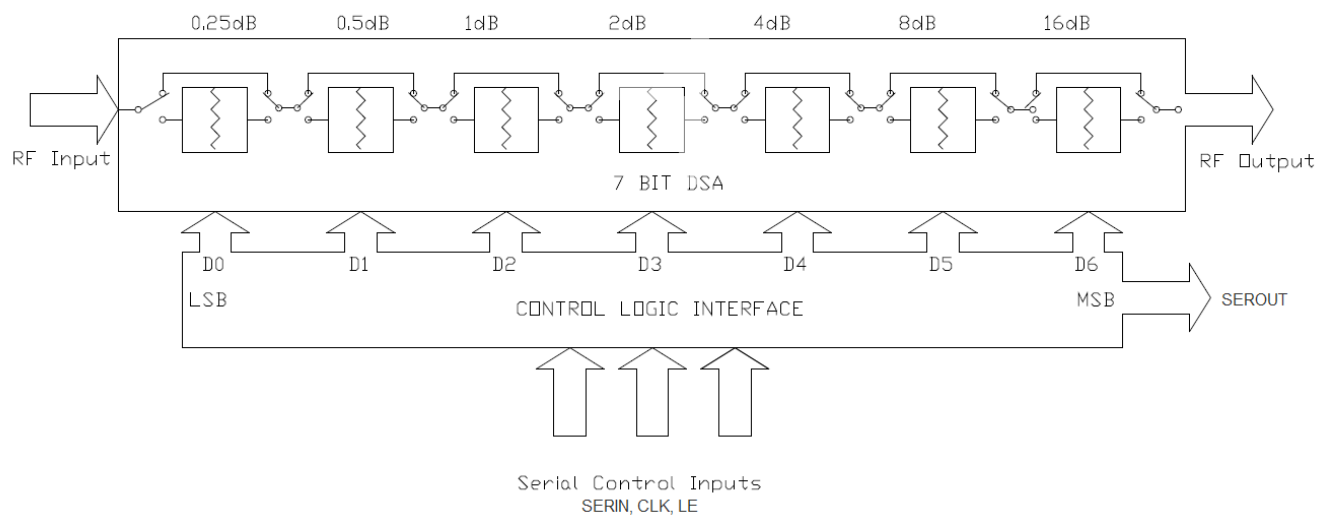

TQP4M9083

High Linearity 7-Bit, 31.75dB Digital Step Attenuator



Pin Description

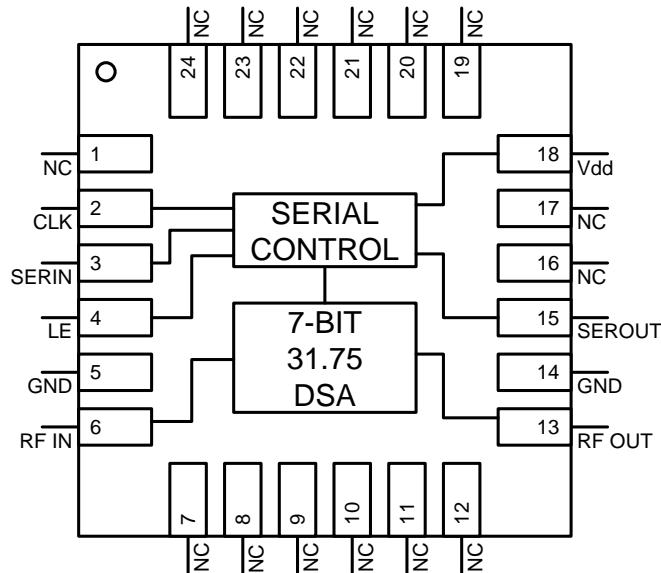

Pin	Symbol	Description
2	CLK	Clock. This serial clock is used to clock in the serial data to the registers. The data is latched on the CLK rising edge. This input is a high impedance CMOS input.
3	SERIN	Serial Input Data. The 7-bit serial data is loaded MSB first. This input is a high impedance CMOS input.
4	LE	Latch Enable, When LE goes high, 7-bit data in the serial input register is transferred to the attenuator. When LE is high, CLK is disabled
6	RF IN	RF Input, DC voltage present, blocking capacitor required. Can be used for Input or Output.
13	RF OUT	RF Output, DC voltage present, blocking capacitor required. Can be used for Input or Output.
15	SEROUT	Serial Output Data
18	V _{dd}	Supply Voltage. Bypass capacitor required close to the pin. Dropping resistor highly recommended ensuring compatibility with different power supplies.
5, 14	GND	These pins must be connected to RF/DC ground
1, 7, 8, 9, 10, 11, 12, 16, 17, 19, 20, 21, 22, 23, 24	N/C	These pins are not connected internally but can be grounded on the PCB
Backside Paddle	GND	Multiple vias should be employed for proper performance; see page 10 for suggested footprint

TQP4M9083

High Linearity 7-Bit, 31.75dB Digital Step Attenuator



Applications Information

PC Board Layout

Top RF layer is .020” Rogers-4003, $\epsilon_r = 3.45$, 4 total layers (0.062” thick) for mechanical rigidity. Metal layers are 1-oz copper. Microstrip line details: width = .040”, spacing = .020”.

External DC blocking capacitors (C1 and C3) are required on RFin and RFout pins of the device. The supply voltage for the DSA is supplied externally through pin Vdd. Frequency bypassing for this pin is supplied by surface mount capacitor 0.1 uF (C4). This capacitor is placed close to the device pin in the board layout. To ensure application circuit is compatible with different standard power supplies, 15 Ω (R4) dropping resistor is highly recommended on Vdd supply line.

RF layout is critical for getting the best performance. RF trace impedance needs to be 50 ohm. For measuring the actual device performance on connectorized PC board, input losses due to RF traces need to be subtracted from the data measured through SMA connectors. The calibration microstrip line J6-J7 estimates the PCB insertion loss for removal from the evaluation board measured data. All data shown on the datasheet are de-embedded up to the device input/output pins.

The PC board is designed to test using USB control interface board, Evaluation Board Host (EVH). Each TQP4M9083 evaluation board is supplied with the EVH board, USB cable and EVH graphical user interface (EVH GUI) to change attenuation states. Manual for using EVH and Application note describing the EVH are also available. Refer to TriQuint’s website for more information

The pad pattern shown has been developed and tested for optimized assembly at TriQuint Semiconductor. The PCB land pattern has been developed to accommodate lead and package tolerances. Since surface mount processes vary from company to company, careful process development is recommended.

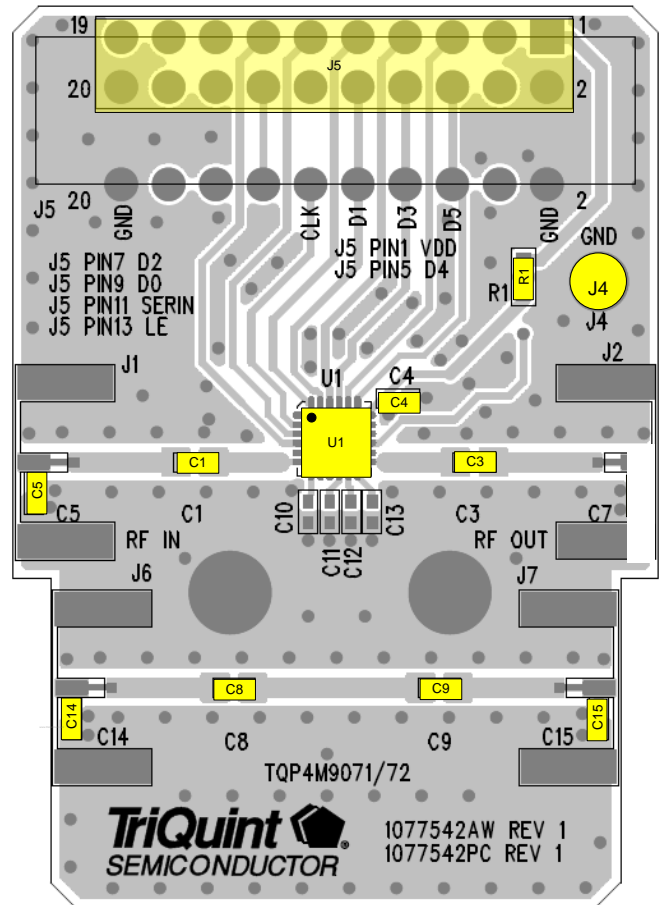

Bill of Material: TQP4M9083-PCB

Reference Desg.	Value	Description	Manufacturer	Part Number
U1		High Linearity 7-Bit, 31.5dB, DSA	TriQuint	TQP4M9083
C1,C3,C8, C9	1000 pF	Cap, Chip, 0402, 50V, X7R, 10%	various	
C4	0.1 uF	Cap, Chip, 0402, 50V, X7R, 10%	various	
R1	15 Ω	Res, Chip, 0402, 1/16W, 5%	various	
C10, C11, C12, C13	DNP	Do Not Place	various	

TQP4M9083

High Linearity 7-Bit, 31.75dB Digital Step Attenuator



Applications Information

PC Board Schematic

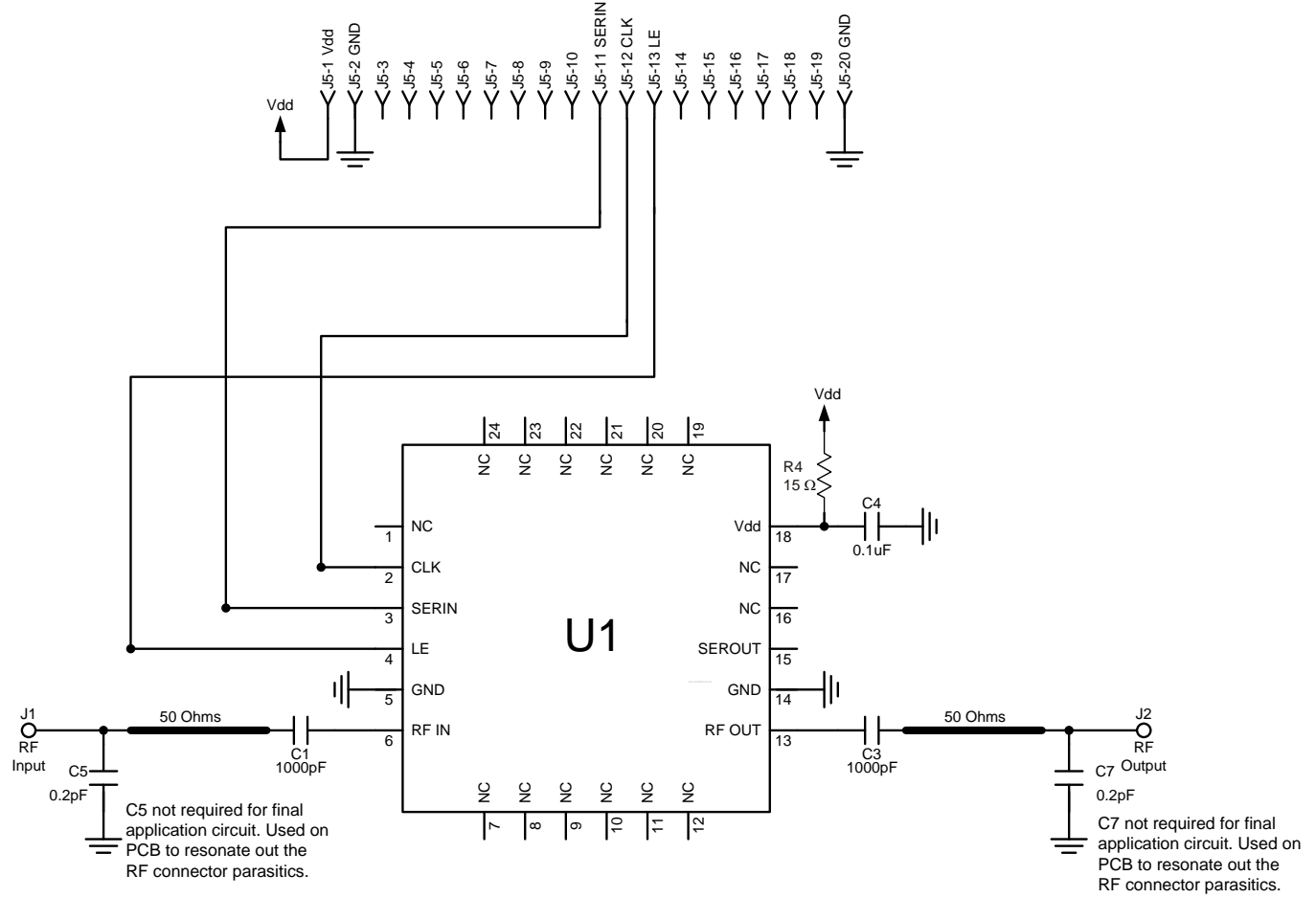

Thru Calibration Line

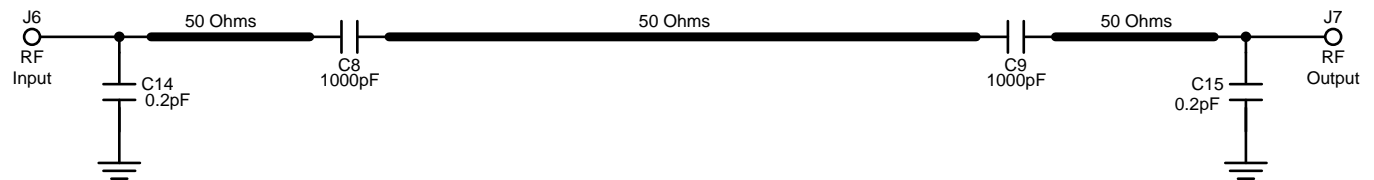

TQP4M9083

High Linearity 7-Bit, 31.75dB Digital Step Attenuator



Mechanical Information

Package Information and Dimensions

This package is lead-free, RoHS-compliant, and green. The plating material on the pins is annealed matte tin over copper. It is compatible with both lead-free (maximum 260 °C reflow temperature) and leaded (maximum 245 °C reflow temperature) soldering processes.

The component will be laser marked with “4M9083” product label with an alphanumeric lot code on the top surface of the package.

NOTES:

- EXCEPT WHERE NOTED, THIS PART OUTLINE CONFORMS TO JEDEC STANDARD MO-220, ISSUE E (VARIATION VGGC) FOR THERMALLY ENHANCED PLASTIC VERY THIN FINE PITCH QUAD FLAT NO LEAD PACKAGE (QFN).
- DIMENSIONING & TOLERANCING CONFORM TO ASME Y14.4M-1994.
- ALL DIMENSIONS ARE IN MILLIMETERS. ANGLES ARE IN DEGREES.
- THE TERMINAL #1 IDENTIFIER AND TERMINAL NUMBERING CONVENTION CONFORM TO JESD 95-1 SPP-012.
- COPLANARITY APPLIES TO THE EXPOSED GROUND/THERMAL PAD AS WELL AS THE TERMINALS.
- PACKAGE BODY LENGTH/WIDTH DOES NOT INCLUDE PLASTIC FLASH PROTRUSION ACROSS MOLD PARTING LINE.
- DEVIATION FROM JEDEC STANDARD MO-229, ISSUE C, 12 LEAD COUNT NOT I

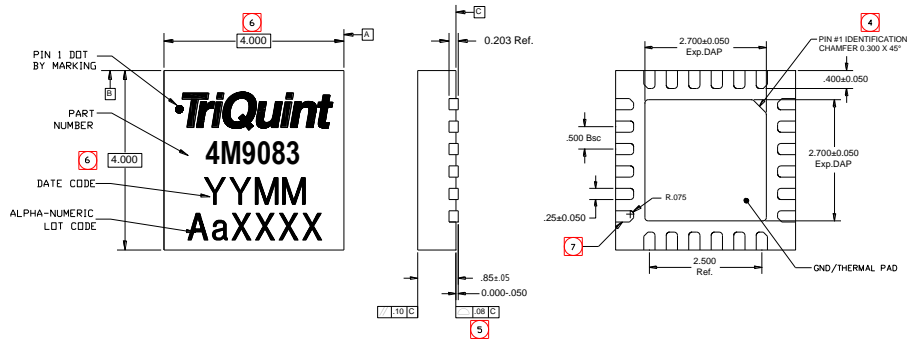

Mounting Configuration

All dimensions are in millimeters (inches). Angles are in degrees.

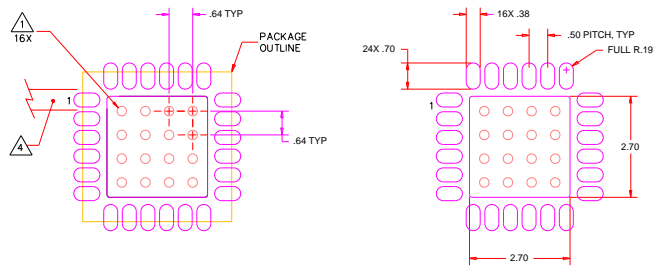

All dimensions are in millimeters (inches). Angles are in degrees.

Notes:

- Ground vias are critical for the proper RF performance of this device. Vias should use a .35mm (#80 / .0135”) diameter drill and have a final plated thru diameter of .25 mm (.010”).
- Add as much copper as possible to inner and outer layers near the part to ensure optimal thermal performance.

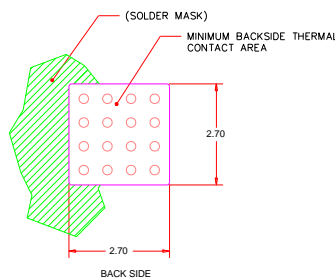

NOTES:

- GROUND/THERMAL VIAS ARE CRITICAL FOR THE PROPER PERFORMANCE OF THIS DEVICE. VIAS SHOULD USE A .35mm (#80/.0135”) DIAMETER DRILL AND HAVE A FINAL, PLATED THRU DIAMETER OF .25mm (.010”).
- ADD AS MUCH COPPER AS POSSIBLE TO INNER AND OUTER LAYERS NEAR THE PART TO ENSURE OPTIMAL THERMAL PERFORMANCE.
- TO ENSURE RELIABLE OPERATION, DEVICE GROUND PADDLE-TO-GROUND PAD SOLDER JOINT IS CRITICAL.
- RF TRACE WIDTH DEPENDS UPON THE PC BOARD MATERIAL AND CONSTRUCTION.
- USE 1 OZ. COPPER MINIMUM.
- ALL DIMENSIONS ARE IN MILLIMETERS. ANGLES ARE IN DEGREES.

TQP4M9083

High Linearity 7-Bit, 31.75dB Digital Step Attenuator



Product Compliance Information

ESD Information



Caution! ESD-Sensitive Device

ESD Rating: Class 1C
Value: Passes ≥ 1000 V to < 2000 V
Test: Human Body Model (HBM)
Standard: JEDEC Standard JESD22-A114

ESD Rating: Class IV
Value: Passes ≥ 1000 V
Test: Charged Device Model (CDM)
Standard: JEDEC Standard JESD22-C101

MSL Rating

MSL 1 at +260 °C convection reflow
The part is rated Moisture Sensitivity Level 1 at 260°C per JEDEC standard IPC/JEDEC J-STD-020.

Solderability

The plating material on the pins is annealed matte tin over copper. It is compatible with both lead-free (maximum 260 °C reflow temperature) and leaded (maximum 245 °C reflow temperature) soldering processes.

This part is compliant with EU 2002/95/EC RoHS directive (Restrictions on the Use of Certain Hazardous Substances in Electrical and Electronic Equipment).

This product also has the following attributes:

- Lead Free
- Halogen Free (Chlorine, Bromine)
- Antimony Free
- TBBP-A (C₁₅H₁₂Br₄O₂) Free
- PFOS Free
- SVHC Free

Contact Information

For the latest specifications, additional product information, worldwide sales and distribution locations, and information about TriQuint:

Web: www.triquint.com
Email: info-sales@tqs.com

Tel: +1.503.615.9000
Fax: +1.503.615.8902

For technical questions and application information:

Email: sjapplications.engineering@tqs.com

Important Notice

The information contained herein is believed to be reliable. TriQuint makes no warranties regarding the information contained herein. TriQuint assumes no responsibility or liability whatsoever for any of the information contained herein. TriQuint assumes no responsibility or liability whatsoever for the use of the information contained herein. The information contained herein is provided "AS IS, WHERE IS" and with all faults, and the entire risk associated with such information is entirely with the user. All information contained herein is subject to change without notice. Customers should obtain and verify the latest relevant information before placing orders for TriQuint products. The information contained herein or any use of such information does not grant, explicitly or implicitly, to any party any patent rights, licenses, or any other intellectual property rights, whether with regard to such information itself or anything described by such information.

TriQuint products are not warranted or authorized for use as critical components in medical, life-saving, or life-sustaining applications, or other applications where a failure would reasonably be expected to cause severe personal injury or death.