



www.DataSheet4U.com

# TS1117I

## 800mA Low Dropout Positive Voltage Regulator

TO-220



TO-263



TO-252



SOT-223



Pin assignment:  
 1. Ground / Adj  
 2. Output  
 3. Input

**Low Dropout Voltage 1.3V max.**

### General Description

The TS1117I Series are high performance positive voltage regulators are designed for use in applications requiring low dropout performance at full rated current, Additionally, the TS1117I Series provides excellent regulation over variations due to changes in line, load and temperature. Outstanding features include low dropout performance at rated current, fast transient response, internal current limiting and thermal shutdown protection of the output device. The TS1117I Series are three terminal regulators with fixed and adjustable voltage options available in popular packages.

This series is offered in 3-pin TO-263, TO-220, TO-252 and SOT-223 package.

### Features

- ✧ Low dropout performance 1.3V max.
- ✧ Full current rating over line and temperature.
- ✧ Fast transient response
- ✧  $\pm 2\%$  Total output regulation over line, load and temperature
- ✧ Adjust pin current max  $90 \mu A$  over temperature
- ✧ Line regulation typical 0.015%.
- ✧ Load regulation typical 0.05%.
- ✧ Fixed/adjustable output voltage
- ✧ TO-220, TO-263 TO-252 and SOT-223 package

### Block Diagram

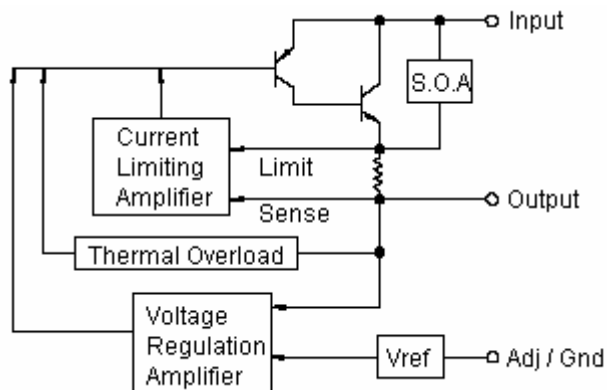

### Ordering Information

| Part No.     | Operating Temp. (Ambient) | Package |
|--------------|---------------------------|---------|
| TS1117ICZ-xx | -40 ~ +85 °C              | TO-220  |
| TS1117ICM-xx |                           | TO-263  |
| TS1117ICP-xx |                           | TO-252  |
| TS1117ICW-xx |                           | SOT-223 |

Note: Where xx denotes voltage option, available are 5.0V, 3.3V, 2.5V and 1.8V. Leave blank for adjustable version. Contact factory for additional voltage options.

### Absolute Maximum Rating

|                                      |                           |                    |    |
|--------------------------------------|---------------------------|--------------------|----|
| Input Supply Voltage                 | V <sub>in</sub>           | 12                 | V  |
| Operation Input Supply Voltage       | V <sub>in (operate)</sub> | 7                  | V  |
| Power Dissipation                    | P <sub>D</sub>            | Internally Limited | W  |
| Operating Junction Temperature Range | T <sub>J</sub>            | -25 ~ +150         | °C |
| Storage Temperature Range            | T <sub>STG</sub>          | -65 ~ +150         | °C |
| Lead Soldering Temperature (260 °C)  |                           |                    |    |
| TO-220 / TO-263 Package              |                           | 10                 | S  |
| TO-252 / SOT-223 Package             |                           | 5                  |    |

| <b>Electrical Characteristics</b>   |  |          |           |          |      |
|---|--|----------|-----------|----------|------|
| Ta = 25 °C, unless otherwise specified. Adjustable version test with Vout = 2.5V. |  |          |           |          |      |
| Parameter   | Conditions                                   | Min      | Typ       | Max      | Unit |
| Output Voltage  | Vout+1.5V ≤ Vin ≤ 7V, Io=10mA                | 0.990 Vo | 5.0 / 3.3 | 1.010 Vo | V    |
|   | Vout+1.5V ≤ Vin ≤ 7V, Io=800mA               | 0.980 Vo | 2.5 / 1.8 | 1.020 Vo | V    |
| Reference Voltage   | (Vin-out) =1.5V, Io=10mA                     | 0.990 Vo | 1.25      | 1.010 Vo | V    |
|   | (Vin-out) =1.5V, Io=800mA                    | 0.980 Vo |           | 1.020 Vo | V    |
| Input Supply Voltage  |  | --       | --        | 7        | V    |
| Line Regulation   | Vout+1.5V ≤ Vin ≤ 7V, Io=10mA                | --       | 0.015     | 0.2      | %    |
| Load Regulation (note 1,2)  | Vin=Vout+1.5V,<br>10mA ≤ Io ≤ 800mA          | --       | 0.05      | 1.0      | %    |
|   |  |          |           |          | %    |
| Dropout Voltage   | Io=1A, ΔVout=1%Vout                          | --       | 1.3       | 1.4      | V    |
| Minimum Load Current  | Vin=5V                                       | --       | 8         | 10       | mA   |
| Adjustable Pin Current  |  | --       | 90        | --       | uA   |
| Current Limit   | Vin - Vout=3V                                | 1.1      | --        | --       | A    |
| Temperature Stability   | Io=10mA                                      | --       | 0.5       | --       | %    |
| Ripple Rejection  | F = 120Hz, Io=1A Cout=25uF,<br>Vin=Vout + 3V | --       | 60        | 70       | dB   |

| <b>Thermal Performance</b>                |              |     |      |
|---|--------------|-----|------|
| Condition                                 | Package type | Typ | Unit |
| Thermal Resistance<br>Junction to Ambient | TO-220       | 85  | °C/W |
|   | TO-263       | 85  |      |
|   | TO-252       | 105 |      |
|   | SOT-223      | 110 |      |

Note 1: See thermal regulation specification for changes in output voltage due to heating effects. Line and load regulation are measured at a constant junction temperature by low duty cycle pulse testing. Load regulation is measured at the output lead = 1/18" from the package.

Note 2: Line and load regulation are guaranteed up to the maximum power dissipation of 15W. Power dissipation is determined by the input / output voltage difference and the output current. Guaranteed maximum power dissipation will not be available over the full input / output voltage range.

Note 3: Quiescent current is defined as the minimum output current required to maintain the regulation.

**Typical Application Circuit**

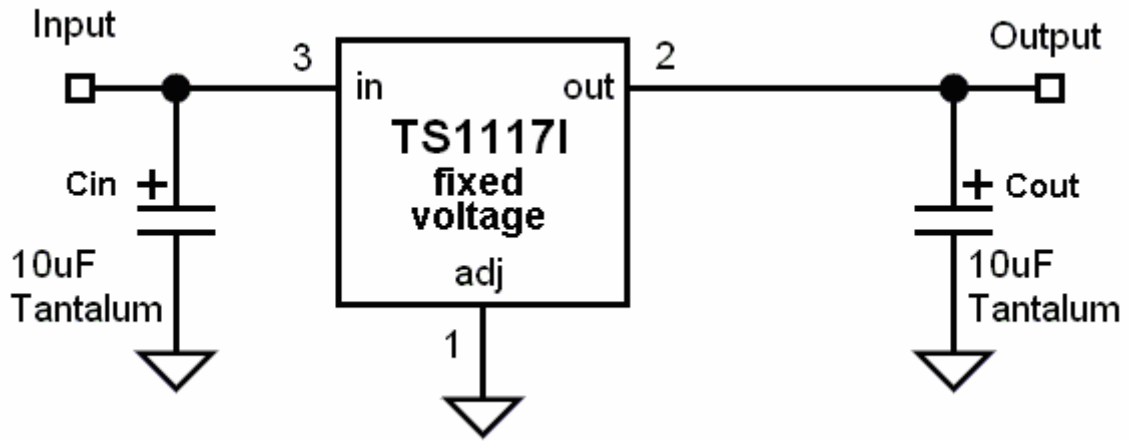

**Fixed output voltage version**

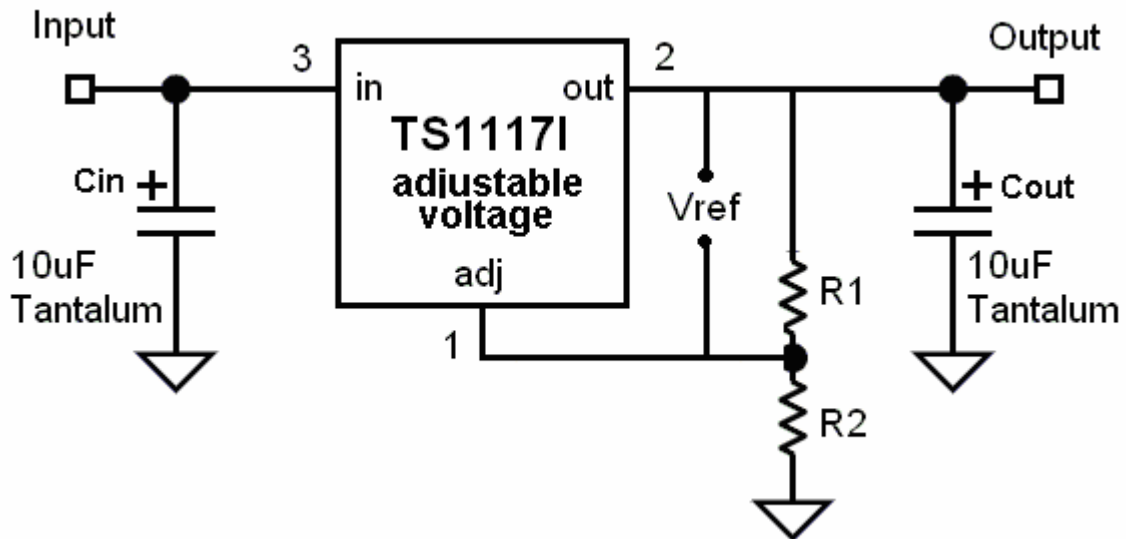

$$V_{out} = V_{ref} * (1 + R2 / R1)$$

\*  $C_{in}$  is requested if regulator is located Far from power supply filter

\*\* Design  $C_{out}$  as close to  $V_{out}$  pin as possible

**Adjustable output voltage version**

## Electrical Characteristics Curve

**Figure 1: dropout voltage v.s. output current**

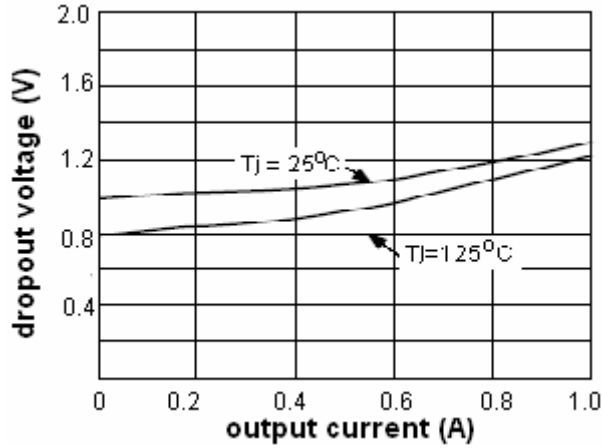

**Figure 2: load regulation v.s. temp.**

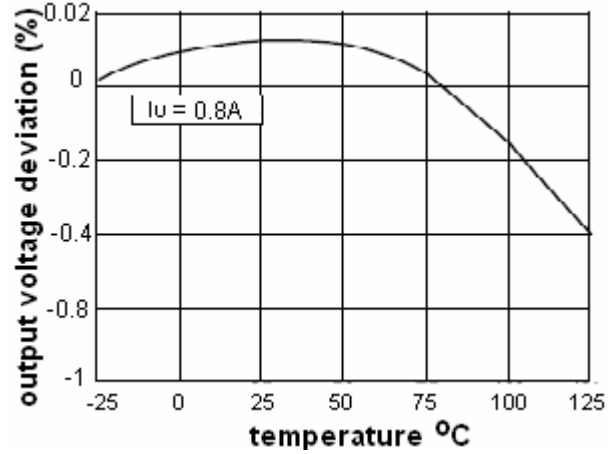

**Figure 3: output change v.s. temp.**

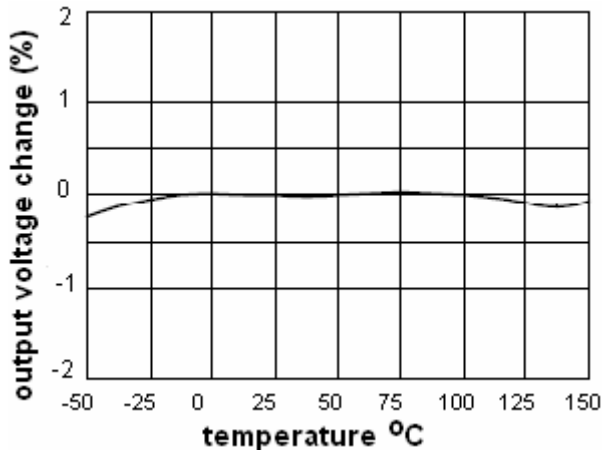

**Figure 4: line regulation**

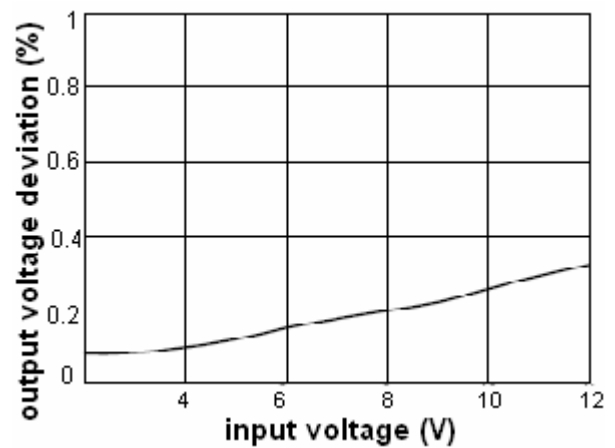

**Figure 5: line transient response**

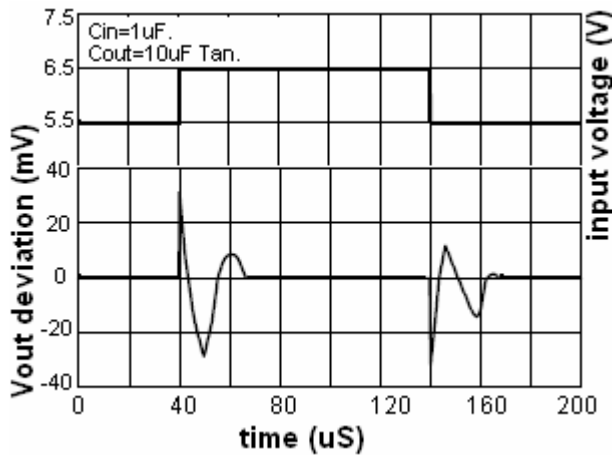

**Figure 6: load transient response**

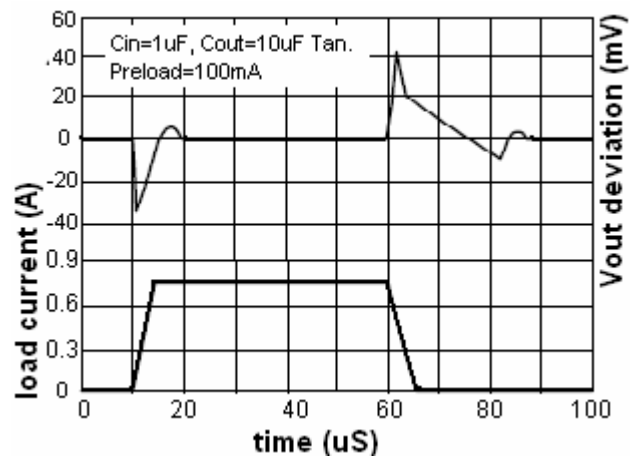

## TO-220 Mechanical Drawing

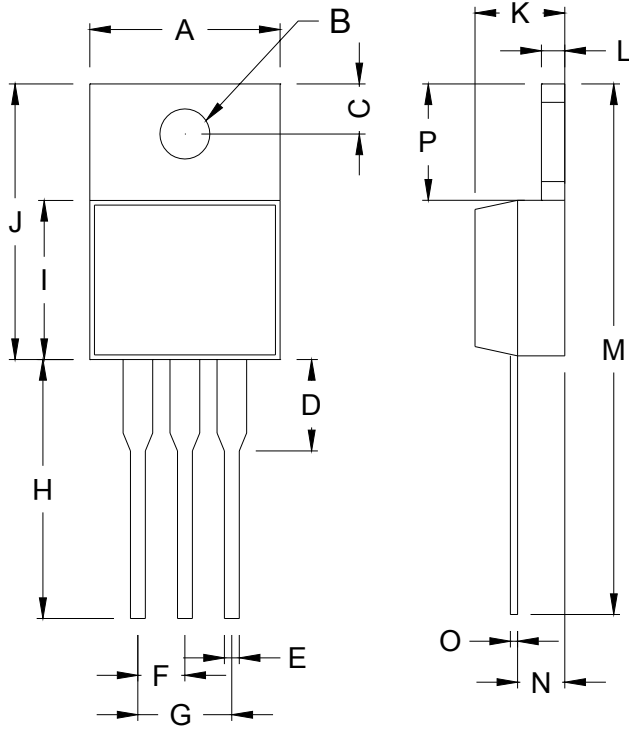

| TO-220 DIMENSION |             |        |        |       |
|------------------|-------------|--------|--------|-------|
| DIM              | MILLIMETERS |        | INCHES |       |
|                  | MIN         | MAX    | MIN    | MAX   |
| A                | 10.000      | 10.500 | 0.394  | 0.413 |
| B                | 3.240       | 4.440  | 0.128  | 0.175 |
| C                | 2.440       | 2.940  | 0.096  | 0.116 |
| D                | -           | 6.350  | -      | 0.250 |
| E                | 0.381       | 1.106  | 0.015  | 0.040 |
| F                | 2.345       | 2.715  | 0.092  | 0.058 |
| G                | 4.690       | 5.430  | 0.092  | 0.107 |
| H                | 12.700      | 14.732 | 0.500  | 0.581 |
| I                | 8.382       | 9.017  | 0.330  | 0.355 |
| J                | 14.224      | 16.510 | 0.560  | 0.650 |
| K                | 3.556       | 4.826  | 0.140  | 0.190 |
| L                | 0.508       | 1.397  | 0.020  | 0.055 |
| M                | 27.700      | 29.620 | 1.060  | 1.230 |
| N                | 2.032       | 2.921  | 0.080  | 0.115 |
| O                | 0.255       | 0.610  | 0.010  | 0.024 |
| P                | 5.842       | 6.858  | 0.230  | 0.270 |

## TO-263 Mechanical Drawing

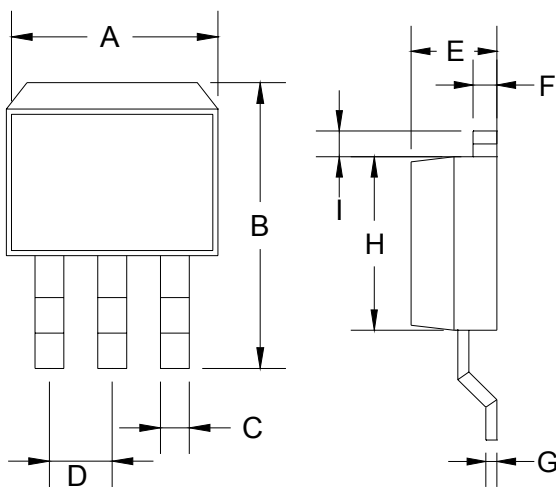

| TO-263 DIMENSION |             |        |        |       |
|------------------|-------------|--------|--------|-------|
| DIM              | MILLIMETERS |        | INCHES |       |
|                  | MIN         | MAX    | MIN    | MAX   |
| A                | 10.000      | 10.500 | 0.394  | 0.413 |
| B                | 14.605      | 15.875 | 0.575  | 0.625 |
| C                | 0.508       | 0.991  | 0.020  | 0.039 |
| D                | 2.420       | 2.660  | 0.095  | 0.105 |
| E                | 4.064       | 4.830  | 0.160  | 0.190 |
| F                | 1.118       | 1.400  | 0.045  | 0.055 |
| G                | 0.450       | 0.730  | 0.018  | 0.029 |
| H                | 8.280       | 8.800  | 0.325  | 0.346 |
| I                | 1.140       | 1.400  | 0.044  | 0.055 |
| J                | 1.480       | 1.520  | 0.058  | 0.060 |

## TO-252 Mechanical Drawing

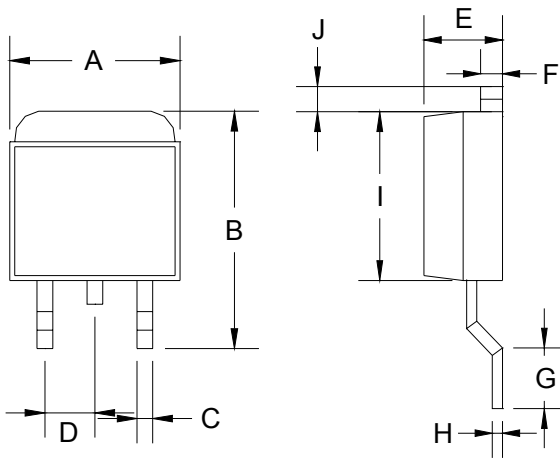

| TO-252 DIMENSION |             |        |        |       |
|------------------|-------------|--------|--------|-------|
| DIM              | MILLIMETERS |        | INCHES |       |
|                  | MIN         | MAX    | MIN    | MAX   |
| A                | 6.570       | 6.840  | 0.259  | 0.269 |
| B                | 9.250       | 10.400 | 0.364  | 0.409 |
| C                | 0.550       | 0.700  | 0.022  | 0.028 |
| D                | 2.560       | 2.670  | 0.101  | 0.105 |
| E                | 2.300       | 2.390  | 0.090  | 0.094 |
| F                | 0.490       | 0.570  | 0.019  | 0.022 |
| G                | 1.460       | 1.580  | 0.057  | 0.062 |
| H                | 0.520       | 0.570  | 0.020  | 0.022 |
| I                | 5.340       | 5.550  | 0.210  | 0.219 |
| J                | 1.460       | 1.640  | 0.057  | 0.065 |

## SOT-223 Mechanical Drawing

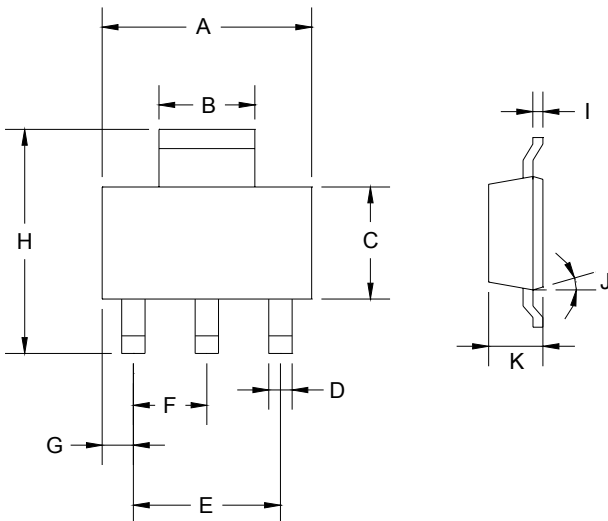

| SOT-223 DIMENSION |             |       |        |       |
|-------------------|-------------|-------|--------|-------|
| DIM               | MILLIMETERS |       | INCHES |       |
|                   | MIN         | MAX   | MIN    | MAX   |
| A                 | 6.350       | 6.850 | 0.250  | 0.270 |
| B                 | 2.900       | 3.100 | 0.114  | 0.122 |
| C                 | 3.450       | 3.750 | 0.136  | 0.148 |
| D                 | 0.595       | 0.635 | 0.023  | 0.025 |
| E                 | 4.550       | 4.650 | 0.179  | 0.183 |
| F                 | 2.250       | 2.350 | 0.088  | 0.093 |
| G                 | 0.835       | 1.035 | 0.032  | 0.041 |
| H                 | 6.700       | 7.300 | 0.263  | 0.287 |
| I                 | 0.250       | 0.355 | 0.010  | 0.014 |
| J                 | 10°         | 16°   | 10°    | 16°   |
| K                 | 1.550       | 1.800 | 0.061  | 0.071 |