



Buck (Step-down) WLED Driver with External Switch

SOT-25



Pin Definition:

1. SW
2. Ground
3. C_T
4. I_{SENSE}
5. V_{IN}

General Description

The TS19372 is a continuous mode inductive step-down converter, designed for driving single or multiple series connected LEDs efficiently from a voltage source higher than the LED voltage. The device operates from an input supply between 6V and 40V and provides 300mA output current to drive external N-channel MOSFET.

TS19372 includes the output switch and a high-side output current sensing circuit, which uses an external resistor to set the nominal average output current.

Features

- Wide Input Voltage Range 6V~40V
- 300mA Output Current
- High Efficiency up to 92%
- Drives up to 3 (1~3W) LEDs @ V_{IN} 12V
- Drives up to 7 (1~3W) LEDs @ V_{IN} 24V
- 180kHz Switching Frequency
- Internal PWM Filter

Application

- LED Flashlights
- White LED Backlighting
- White LED Driving
- Multiple LED Driving
- LED Lighting Equipment

Ordering Information

Part No.	Package	Packing
TS19372CX5 RF	SOT-25	3Kpcs / 7" Reel

Block Diagram

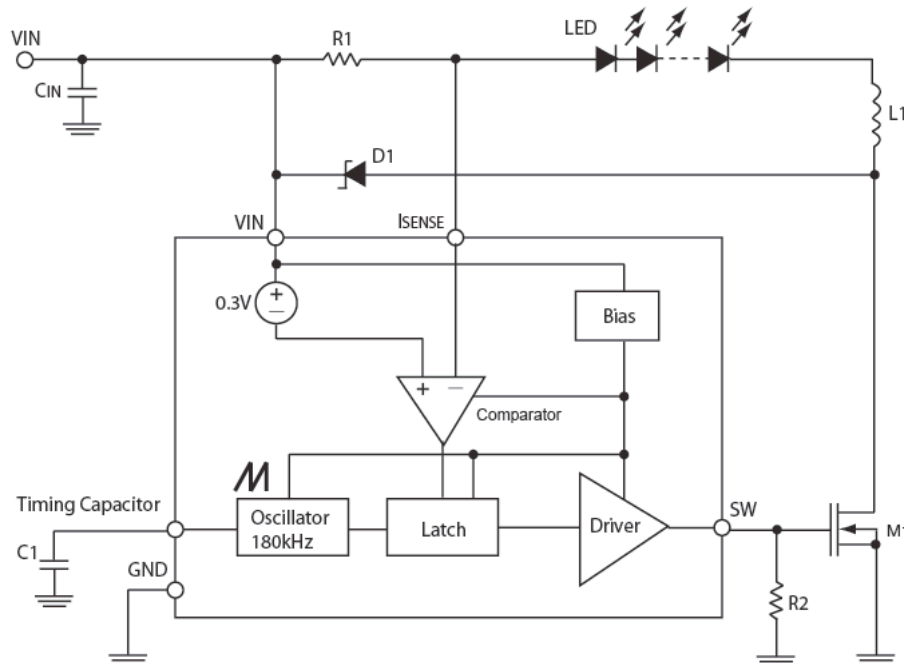

Buck (Step-down) WLED Driver with External Switch

Absolute Maximum Rating

Parameter	Symbol	Limit	Unit
Input Voltage	V_{IN}	40	V
Supply Voltage (Recommended)	V_{IN}	6 ~ 40	V
FB Voltage	V_{FB}	-0.3 ~ 40	V
SW Voltage	V_{SW}	36	V
Output SW Current	I_{SW}	300	mA
Power Dissipation	P_D	450	mW
Ambient Temperature Range	T_A	-40 to +85	°C
Junction Temperature Range	T_J	+150	°C

Electrical Specifications (Ta = 25°C, unless otherwise noted)

Parameter	Symbol	Test Conditions	Min	Typ	Max	Units
Input Voltage Range	V_{IN}		6	--	40	V
Line Regulation	REG_{LINE}		--	1.4	5	mV
Charge Current	I_{CHARGE}	$V_{IN} = 6V \sim 40V$	--	30	45	uA
Discharge Current	$I_{DISCHARGE}$	$V_{IN} = 6V \sim 40V$	180	230	290	uA
Switching Frequency	F_{OSC}	$C_T = 100pF,$	--	180	--	kHz
Current Limit Sense Voltage	V_{SENSE}	$I_{DISCHARGE} = I_{CHARGE}$	250	--	350	mV
Switch V_{CESAT}	V_{SAT}	$I_{SW} = 300mA$	--	1.0	1.3	V
Supply Current	I_{CC}	$V_{IN} = 6V \sim 40V, C_T = 1nF$	--	3	4	mA
Collector off-state Current	$I_{C(OFF)}$	$V_{CE} = 40V$		1	100	uA

Note: Low duty cycle pulse techniques are used during test to maintain junction temperature as close to ambient temperature as possible

Buck (Step-down) WLED Driver with External Switch

Application Information

Pin Description

Pin	Function	Description
1	SW	Driver Switching Pin
2	Ground	Ground Pin.
3	Timing Capacitor	Timing capacitor oscillator input
4	I _{SENSE}	Peak current sense input to monitor the voltage drop across an external resistor to limit the peak current through the circuit
5	VIN	Input Voltage Supply pin

Inductor Selection

A 100uH inductor is recommended for most TS19372 applications. Although small size and high efficiency are major concerns, the inductor should have low core losses at 180kHz and low DCR (copper wire resistance).

Diode Selection

Schottky diodes, with their low forward voltage drop and fast reverse recovery, are the ideal choices for TS19372 applications. The forward voltage drop of a Schottky diode represents the conduction losses in the diode while the diode capacitance represents the switching losses. For diode selection, both forward voltage drop and diode capacitance need to be considered. Schottky diodes with higher current ratings usually have lower forward voltage drop and larger diode capacitance, which can cause significant switching losses at the 180kHz switching frequency of the TS19372.

Capacitor Selection

For Input capacitor and timing capacitor are able to use small ceramic capacitor for most of TS19372 applications. When AC input, to add a 100μF electric capacitor for input capacitor is recommended.

Buck (Step-down) WLED Driver with External Switch

Typical Application Circuit

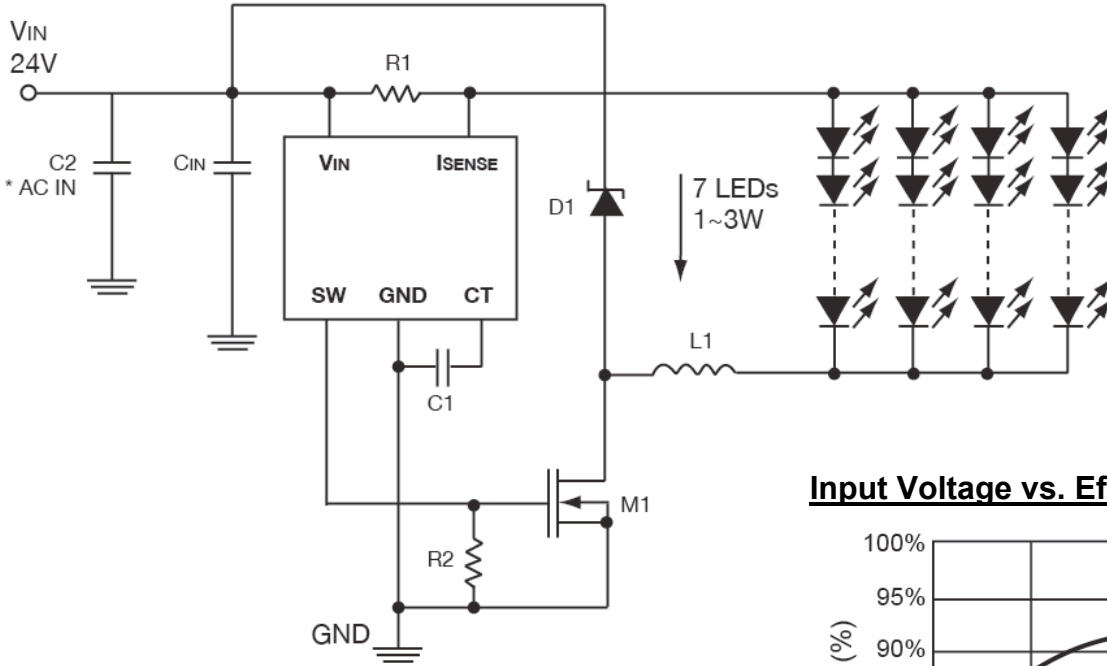

Input Voltage vs. Efficiency

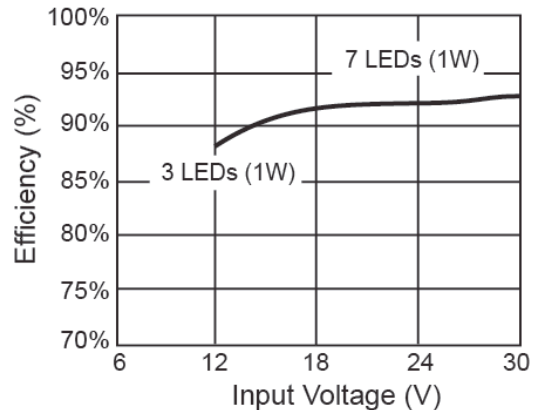

Reference Design Information

VIN Range (V)	L (uH)	1W LED (Series)	1W LED (Parallel)	Current (mA)	Efficiency (%)
12	68	3pcs	4	300	88
24	100	7pcs	4	300	92

Bill of Materials:

Designation	Description	Package	Manufacture	Remark
LED Driver	TS19372CX5	SOT-25	TSC	--
D1	SS34	SMB	TSC	3A, 40V
M1	TSM2318CX	SOT-23	TSC	N-CH 40V / 3.9A
L1	100uH	--	Generic	Isat >1.5A
R1	0.22Ω	1206	Generic	--
R2	1kΩ	1206	Generic	--
Cin	10uF	805	Generic	Ceramic
C1	820pF	805	Generic	Ceramic
C2	100uF		Generic	Tantalum or Electrolysis * AC Input

Buck (Step-down) WLED Driver with External Switch

SOT-25 Mechanical Drawing

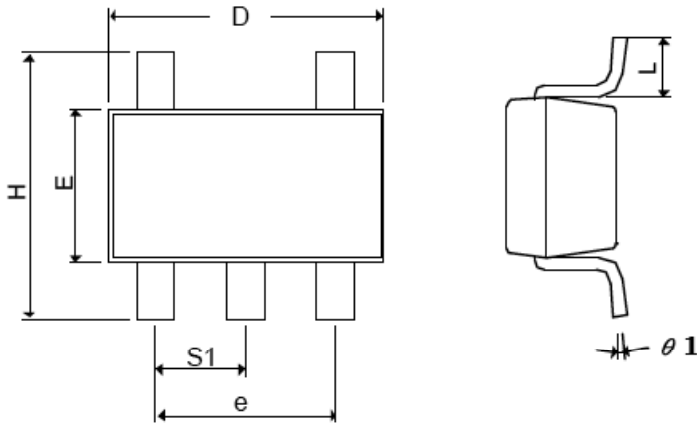

SOT-25 DIMENSION				
DIM	MILLIMETERS		INCHES	
	MIN	MAX	MIN	MAX.
A+A1	0.09	1.25	0.0354	0.0492
B	0.30	0.50	0.0118	0.0197
C	0.09	0.25	0.0035	0.0098
D	2.70	3.10	0.1063	0.1220
E	1.40	1.80	0.0551	0.0709
e	1.90 BSC		0.0748 BSC	
H	2.40	3.00	0.09449	0.1181
L	0.35 BSC		0.0138 BSC	
θ1	0°	10°	0°	10°
S1	0.95 BSC		0.0374 BSC	

Front View

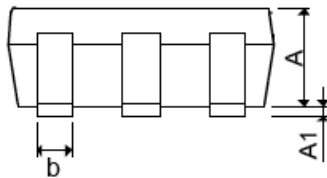

Marking Diagram

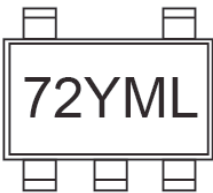

- 72** = Device Code
- Y** = Year Code
- M** = Month Code
(A=Jan, B=Feb, C=Mar, D=Apl, E=May, F=Jun, G=Jul, H=Aug, I=Sep, J=Oct, K=Nov, L=Dec)
- L** = Lot Code

Buck (Step-down) WLED Driver with External Switch

Notice

Specifications of the products displayed herein are subject to change without notice. TSC or anyone on its behalf, assumes no responsibility or liability for any errors or inaccuracies.

Information contained herein is intended to provide a product description only. No license, express or implied, to any intellectual property rights is granted by this document. Except as provided in TSC's terms and conditions of sale for such products, TSC assumes no liability whatsoever, and disclaims any express or implied warranty, relating to sale and/or use of TSC products including liability or warranties relating to fitness for a particular purpose, merchantability, or infringement of any patent, copyright, or other intellectual property right.

The products shown herein are not designed for use in medical, life-saving, or life-sustaining applications. Customers using or selling these products for use in such applications do so at their own risk and agree to fully indemnify TSC for any damages resulting from such improper use or sale.