

Single-Stage Low THD Buck-Boost PWM Control LED Driver

DESCRIPTION

The TS19730 is a high power factor, low THD and high accuracy constant current PWM controller. TS19730 achieves high power factor and high efficiency by discontinuous conduction mode (DCM). The line and load regulation of LED current are within $\pm 2.5\%$. TS19730 also provides gate driving voltage clamping, V_{CC} over-voltage protection, and system output open/short circuit protection to increase IC performance.

FEATURES

- Low THD <10%
- Constant Current Accuracy within $\pm 2.5\%$
- High Power Factor >0.9
- Low BOM Cost
- Discontinuous Conduction Mode Control
- Gate Output Voltage Clamp
- LED Open Protection
- LED Short protection
- Over Current Protection (OCP)
- Over Thermal Protection (OTP)
- Compliant to RoHS Directive 2011/65/EU and in accordance to WEEE 2002/96/EC.
- Halogen-free according to IEC 61249-2-21

APPLICATION

- LED lighting
- Down lights, Tube lamps, PAR Lamps, Bulbs

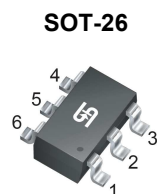

Pin Definition:

1. V_{CC}
2. GND
3. OUT
4. CL
5. COM
6. CS

Note: MSL 3 (Moisture Sensitivity Level) per J-STD-020

ABSOLUTE MAXIMUM RATINGS <small>(Note 1)</small>			
PARAMETER	SYMBOL	LIMIT	UNIT
Power Supply Pin	V_{CC}	40	V
CL Voltage to GND	V_{CL}	-0.3 to 5.5	V
OUT Voltage to GND	V_{OUT}	-0.3 to 40	V
CS Voltage to GND	V_{CS}	-0.3 to 5.5	V
COM Voltage to GND	V_{COM}	-0.3 to 5.5	V
Junction Temperature Range	T_J	-40 to +150	°C
Storage Temperature Range	T_{STG}	-65 to +150	°C
Lead Temperature (Soldering 10s)	T_{LEAD}	260	°C
Power Dissipation @ $T_A=25^\circ\text{C}$	P_D	0.3	W
ESD Rating (Human Body Mode) <small>(Note2)</small>	HBM	2	kV
ESD Rating (Machine Mode) <small>(Note 2)</small>	MM	200	V

THERMAL PERFORMANCE

PARAMETER	SYMBOL	LIMIT	UNIT
Thermal Resistance - Junction to Case	$R_{\theta JC}$	106.6	$^{\circ}C/W$
Thermal Resistance - Junction to Ambient	$R_{\theta JA}$	220	$^{\circ}C/W$

Note: $R_{\theta JA}$ is the sum of the junction-to-case and case-to-ambient thermal resistances. The case thermal reference is defined at the solder mounting surface of the drain pins. $R_{\theta JA}$ is guaranteed by design while $R_{\theta CA}$ is determined by the user's board design. $R_{\theta JA}$ shown below for single device operation on FR-4 PCB in still air. Thermal Resistance is specified with the component mounted on a low effective thermal conductivity test board in free air at $T_A=25^{\circ}C$.

RECOMMENDED OPERATING CONDITIONS (Note 3)

PARAMETER	SYMBOL	CONDITIONS	UNIT
Power Supply Pin	V_{CC}	33	V
CL Voltage to GND	V_{CL}	-0.3 to 5	V
OUT Voltage to GND	V_{OUT}	-0.3 to 19	V
CS Voltage to GND	V_{CS}	-0.3 to 5	V
COM Voltage to GND	V_{COM}	-0.3 to 5	V
Operating Junction Temperature Range	T_J	-40 to +125	$^{\circ}C$
Operating Ambient Temperature Range	T_{OPA}	-40 to +85	$^{\circ}C$

ELECTRICAL SPECIFICATIONS ($V_{CC} = 18V$, $T_A = 25^{\circ}C$ unless otherwise noted)

PARAMETER	SYMBOL	CONDITIONS	MIN	TYP	MAX	UNIT
Supply Voltage						
Start-up Current	$V_{CC(ST)}$	$V_{CC} = V_{UVLO(on)} - 1V$	--	45	--	μA
Operating Current	I_{OPA}	With 1nF load on out pin	--	2.1	2.6	mA
UVLO(off)	$V_{UVLO(off)}$		7	8	9	V
UVLO(on)	$V_{UVLO(on)}$		16	17.5	19	V
OVP Level on V_{CC} Pin	V_{OVP}		29	31	33	V
Voltage Feedback						
Feedback Reference Voltage	V_{FB}		0.196	0.2	0.204	V
Transconductance	g_m		--	58	--	μS
Output Sink Current	I_{O-SINK}		--	5.8	--	μA
Output Source Current	$I_{O-SOURCE}$		--	5.8	--	μA
Current Sensing						
Open Loop Voltage	V_{OLP}	CS Pin Open	--	5	--	V
Leading-Edge Blanking Time	t_{LEB}		--	400	--	ns
Delay to Output	t_{DELAY}		--	100	--	ns
Current Limit						
CL Limit Voltage	V_{OCP}		--	0.3	--	V
Switching Frequency						
Start Frequency	f_{STR}		--	4.5	--	kHz

ELECTRICAL SPECIFICATIONS ($V_{CC} = 18V, T_A = 25^{\circ}C$ unless otherwise noted)						
PARAMETER	SYMBOL	CONDITIONS	MIN	TYP	MAX	UNIT
Gate Driver Output						
Rising Time	t_{RISE}	Load Capacitance =1nF	--	90	--	ns
Falling Time	t_{FALL}	Load Capacitance =1nF	--	40	--	ns
VGATE-Clamp	V_{GATE}		--	12.5	15	V
Thermal Section (Note 5,6)						
Thermal Shutdown			--	150	--	$^{\circ}C$
Thermal Shutdown Release			--	120	--	$^{\circ}C$

Note:

1. Stresses listed as the above "Absolute Maximum Ratings" may cause permanent damage to the device. These are for stress ratings. Functional operation of the device at these or any other conditions beyond those indicated in the operational sections of the specifications is not implied. Exposure to absolute maximum rating conditions for extended periods may remain possibility to affect device reliability.
2. Devices are ESD sensitive. Handling precaution recommended.
3. Thermal Resistance is specified with the component mounted on a low effective thermal conductivity test board in free air at $T_A=25^{\circ}C$.
4. The device is not guaranteed to function outside its operating conditions.
5. Guaranteed by design.
6. Auto Recovery Type.

ORDERING INFORMATION

PART NO.	PACKAGE	PACKING
TS19730CX6 RFG	SOT-26	3,000pcs / 7" Reel

BLOCK DIAGRAM

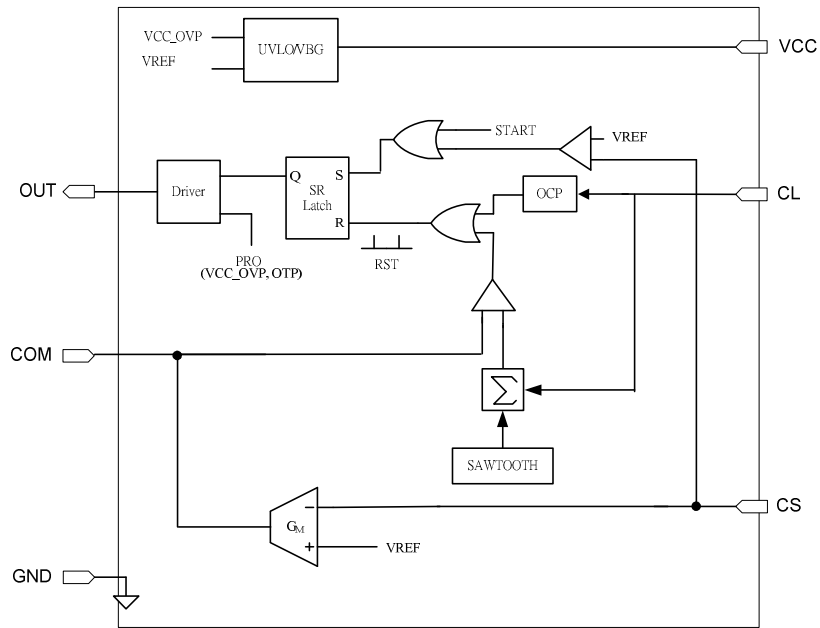

Fig. 1

PIN DESCRIPTION

PIN NO.	NAME	FUNCTION
1	V_{CC}	Power supply pin for all internal circuitry.
2	GND	Ground return for all internal circuitry.
3	OUT	Gate driver output.
4	CL	Current limit.
5	COM	Output pin of error amplifier.
6	CS	Input current sense pin.

TYPICAL APPLICATION CIRCUIT

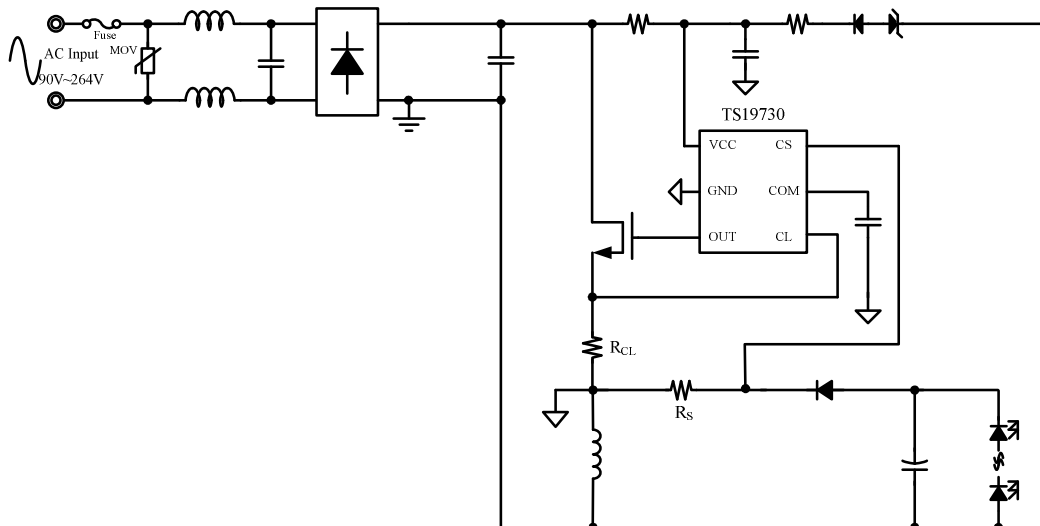

Fig. 2

APPLICATION INFORMATION

Start-up Current

The typical start-up current is around 45µA. Very low start-up current allows the PWM controller to increase the value of start-up resistor and then reduce the power dissipation.

UVLO(Under Voltage Lockout)

A hysteresis UVLO comparator is implemented in TS19730. The turn-on and turn-off thresholds level are fixed at 17.5V and 8V respectively. This hysteresis shown in Fig.3 ensures that the start-up capacitor will be adequate to supply the chip during start-up. For quick start-up of the LED driver, the start-up resistor should be matched with the start-up capacitor.

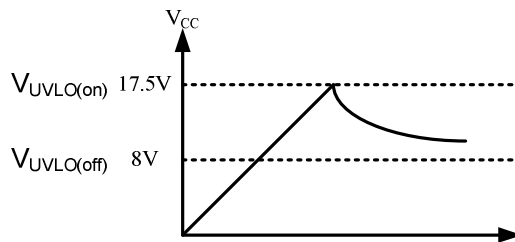

Fig. 3

LEB(Leading-Edge Blanking)

Each time the power MOSFET is switched on, a turn-on spike will inevitably occur at the sense resistor. To avoid fault trigger, a 400ns leading-edge blanking time is built in. Conventional RC filtering can therefore be omitted. During this blanking period, the current-limit comparator is disabled and cannot switch off the gate driver.

OCP(Over Current Protection)

The TS19730 has built-in cycle by cycle over current protection function on CL pin. As the CL pin voltage is larger than V_{OCP} (0.3V), the gate output will be turned off immediately to avoid the driver board to be burned out.

Application Information (Continue)

OVP (Over Voltage Protection) on V_{CC}

To prevent the LED driver from being damaged, the TS19730 has an implemented OVP function on V_{CC}. When the V_{CC} voltage is higher than the V_{OVP} (31V), the output gate driver circuit will be shut down immediately to stop the switching of power MOSFET. The V_{CC} pin OVP function is an auto recovery type protection. If the OVP condition happens, the pulses will be stopped until the V_{CC} pin voltage is down to the UVLO off level. The TS19730 is working in an auto-recovery mode as shown in Fig. 4.

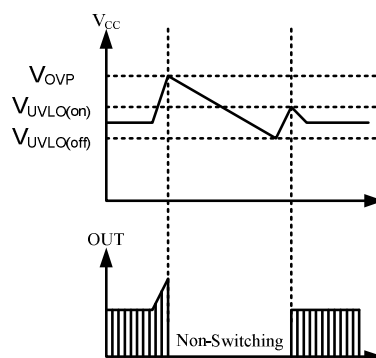

Fig. 4

Gate Clamp

Driver is clamped to 12.5V by an internal clamping circuit to avoid the Gate of MOSFET to get damaged.

PACKAGE OUTLINE DIMENSIONS (Unit: Millimeters)

SOT-26

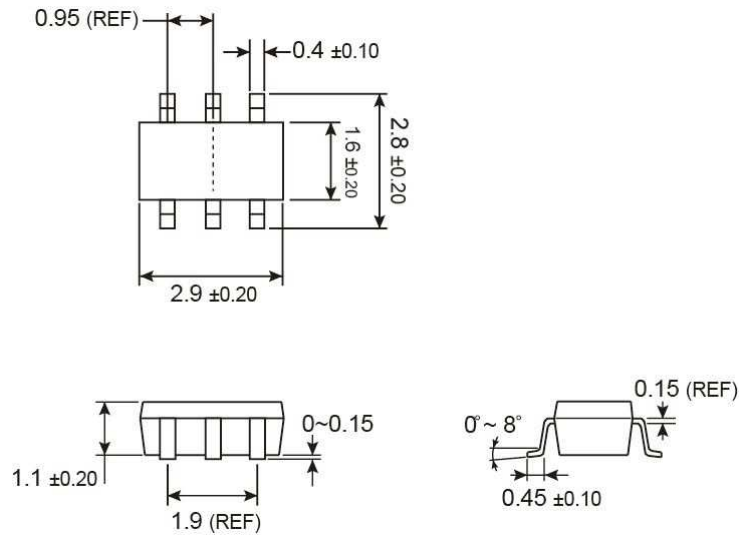

SUGGESTED PAD LAYOUT (Unit: Millimeters)

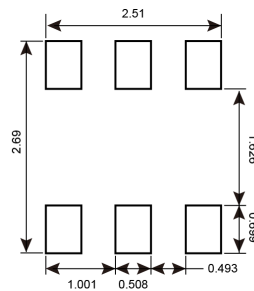

MARKING DIAGRAM

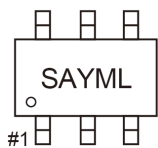

- SA** = Device Code
- Y** = Year Code
 - D** =2014 **E** =2015 **F** =2016 **G** =2017
 - H** =2018 **J** =2019 **K** =2020
- W** = Week Code
 - A~Z** =wk1~wk26
 - A~Z** = wk27~wk52
- L** = Lot Code A~Z

Notice

Specifications of the products displayed herein are subject to change without notice. TSC or anyone on its behalf, assumes no responsibility or liability for any errors or inaccuracies.

Information contained herein is intended to provide a product description only. No license, express or implied, to any intellectual property rights is granted by this document. Except as provided in TSC's terms and conditions of sale for such products, TSC assumes no liability whatsoever, and disclaims any express or implied warranty, relating to sale and/or use of TSC products including liability or warranties relating to fitness for a particular purpose, merchantability, or infringement of any patent, copyright, or other intellectual property right.

The products shown herein are not designed for use in medical, life-saving, or life-sustaining applications. Customers using or selling these products for use in such applications do so at their own risk and agree to fully indemnify TSC for any damages resulting from such improper use or sale.