



SOP-8

Pin Definition:



- | | |
|-----------|--------|
| 1. FB | 5. Vss |
| 2. Enable | 6. Vcc |
| 3. Ocset | 7. SW |
| 4. Vcc | 8. SW |

General Description

TS2508A consists of step-down switching regulator with PWM control. These device include a reference voltage source, oscillation circuit, error amplifier, internal PMOS and etc. TS2508A provides low-ripple power, high efficiency, and excellent transient characteristics. The PWM control circuit is able to vary the duty ratio linearly from 0 up to 100%. This converter also contains an error amplifier circuit as well as a soft-start circuit that prevents overshoot at startup. An enable function, an over current protect function and short circuit protect function are built inside, and when OCP or SCP happens, the operation frequency will be reduced. Also, an internal compensation block is built in to minimum external component count. With the addition of an internal P-channel Power MOS, a coil, capacitors, and a diode connected externally, these ICs can function as step-down switching regulators. They serve as ideal power supply units for portable devices when coupled with the SOP-8 package, providing such outstanding features as low current consumption. Since this converter can accommodate an input voltage up to 20V, it is also suitable for the operation via an AC adapter.

Features

- Input Voltage: 3.6V~23V
- Output Voltage: 0.8V~Vcc
- Duty Ratio: 0%~100% PWM Control
- Oscillation Frequency: 330kHz typ.
- Soft-Start (SS), Current Limit (CL), Enable Function
- Thermal Shutdown Function
- Short Circuit Protect (SCP)
- Built-in Internal SW P-Channel MOSFET

Ordering Information

Part No.	Package	Packing
TS2508ACS RL	SOP-8	2.5Kpcs / 13" Reel

Application

- Simple High-efficiency Step down Regulator
- On-Card Switching Regulators

Absolute Maximum Rating

Parameter	Symbol	Rating	Unit
VCC Pin Voltage	V _{CC}	Gnd -0.3 to Gnd +25	V
Feedback Pin Voltage	V _{FB}	Gnd -0.3 to VCC	V
ON/OFF Pin Voltage	V _{EN}	Gnd -0.3 to VCC +0.3	V
Switch Pin Voltage	V _{SW}	Gnd -0.3 to VCC +0.3	V
Power Dissipation	P _D	Internally limited	mW
Storage Temperature Range	T _{ST}	-40 to +150	°C
Operating Temperature Range	T _{OP}	-20 to +125	°C
Operating Supply Voltage	V _{OP}	+3.6 to +23	V
Output Current	I _O	3	A
Thermal Resistance from Junction to case	θ _{JC}	25	°C/W
Thermal Resistance from Junction to ambient	θ _{JA}	70	°C/W

Electrical Specifications ($V_{IN}=12V$, $T_a=25^{\circ}C$ unless otherwise noted)

Characteristics	Symbol	Conditions	Min	Typ	Max	Units	
Feedback Voltage	V_{FB}	$I_{OUT}=0.1A$	0.784	0.800	0.816	V	
Quiescent Current	I_q	$V_{FB}=1.2V$ force driver off	--	3	5	mA	
Feedback Bias Current	I_{FB}	$I_{OUT}=0.1A$	--	0.1	0.5	uA	
Shutdown Supply Current	I_{SD}	$V_{EN}=0V$	--	2	10	uA	
OCSET pin bias current	I_{OCSET}		110	130	150	uA	
Switch Current	I_{SW}		4	--	--	A	
Line Regulation	$\Delta V_{OUT}/V_{OUT}$	$V_{CC} = 5V\sim 20V$, $I_{OUT}=0.2A$	--	1	2	%	
Load Regulation	I_{OCSET}	$I_{OUT} = 0.1$ to $3A$	--	0.3	0.5	%	
Oscillation Frequency	F_{OSC}	SW pin	260	330	400	KHz	
EN Pin Logic input threshold voltage	V_{SH}	High (regulator ON)	2.0	--	--	V	
	V_{SL}	Low (regulator OFF)	--	--	0.8		
EN Pin Input Current	I_{SH}	$V_{EN}=2.5V$ (ON)	--	20	--	uA	
	I_{SL}	$V_{EN}=0.3V$ (OFF)	--	-10	--	uA	
Soft-Start Time	T_{SS}		0.3	4	8	ms	
Internal P-MOS R_{DSON}	R_{DSON}	$V_{CC} = 5V$, $V_{FB} = 0V$	--	90	140	m Ω	
		$V_{CC} = 12V$, $V_{FB} = 0V$	--	55	90	m Ω	
Efficiency	E_{FFI}	$V_{CC} = 12V$, $V_{OUT} = 5V$	$I_{OUT} = 2A$	--	92	--	%
			$I_{OUT} = 3A$	--	91	--	

Block Diagram

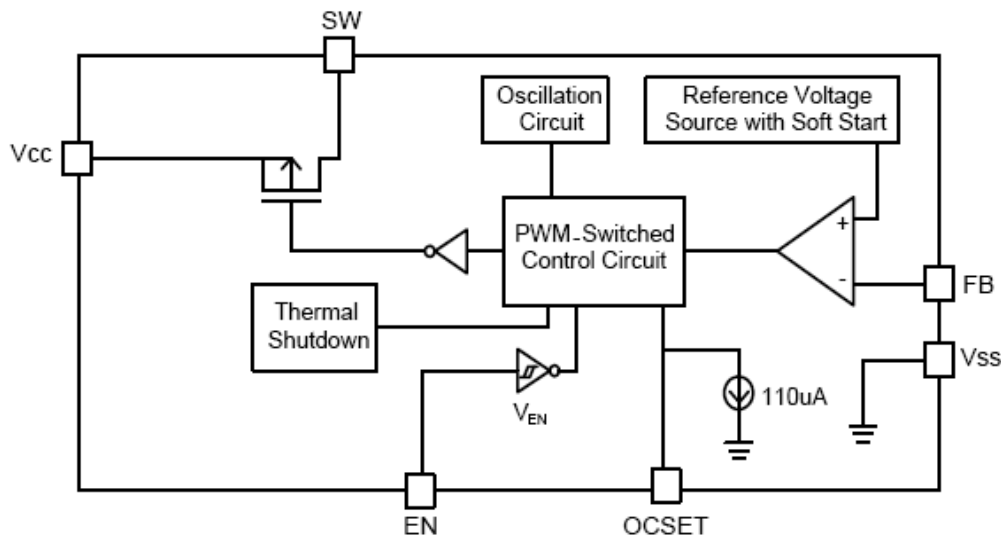

Pin Assignment

Name	Description	Name	Description
FB	Feedback pin	Vss	GND pin
EN	H:Normal operation (Step-down) L:Step-down operation stopped (All circuit deactivated)	Vss	GND pin
OCSET	Add an external resistor to set max switch output current.	SW	Switch pin. Connect external inductor & diode here
Vcc	IC power supply pin	SW	Switch pin. Connect external inductor & diode here

Application Circuit

Typical Circuit

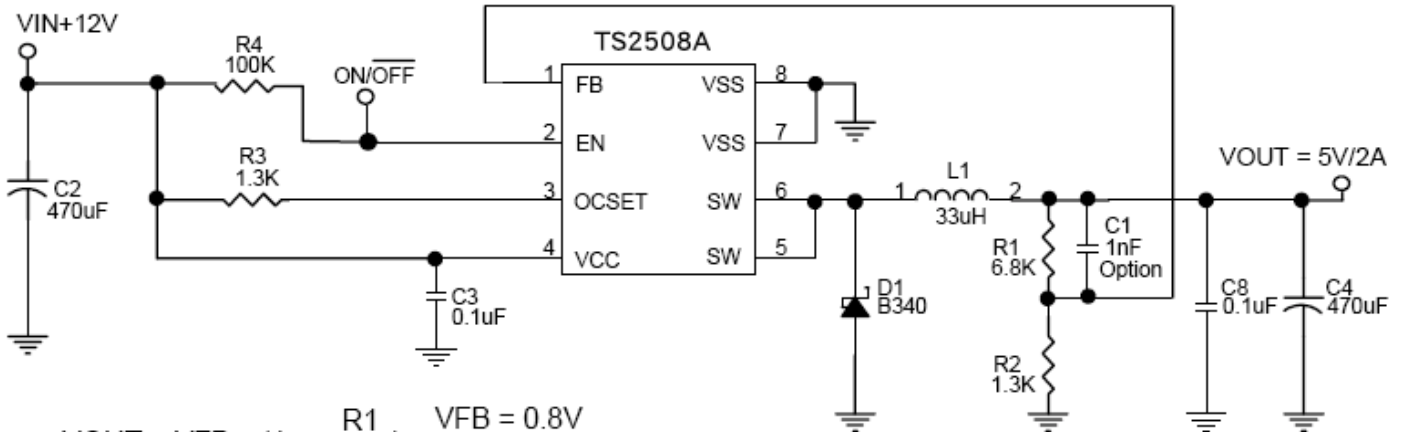

$$V_{OUT} = V_{FB} \times \left(1 + \frac{R1}{R2}\right) \quad V_{FB} = 0.8V \quad R2 \text{ suggest } 0.8K \sim 6k$$

L1 recommend value (VIN=12V, IOUT=3A)				
V _{OUT}	1.8V	2.5V	3.3V	5V
L1 Value	18uH	22uH	27uH	33uH

Function Descriptions

PWM Control

The TS2508A consists of DC/DC converters that employ a pulse-width modulation (PWM) system. In converters of the TS2508A, the pulse width varies in a range from 0 to 100%, according to the load current. The ripple voltage produced by the switching can easily be removed through a filter because the switching frequency remains constant. Therefore, these converters provide a low-ripple power over broad ranges of input voltage and load current.

RDS(ON) Current Limiting

The current limit threshold is setting by the external resistor (R3) connecting from V_{CC} supply to OCSET pin. The internal 110uA sink current crossing the resistor sets the voltage at pin of OCSET. When the PWM voltage is less than the voltage at OCSET, an over-current condition is triggered. Please refer to the formula for setting the minimum current limit value:

$$I_{SW(MIN)} = \frac{I_{OCSET} \times R3 + 0.08}{R_{DS(ON)}} \quad (\text{Normally, The } I_{SW(MAX)} \text{ setting more than } I_{OUT} \text{ 1.2A})$$

Example: $I_{SW} = (0.11mA \times 2k + 0.08) / 70m\Omega = 4.3A - (V_{IN}=12V)$
 $I_{SW} = (0.11mA \times 3.3k + 0.08) / 1000m\Omega = 4.4A - (V_{IN}=5V)$

Function Descriptions (Continue)

Setting the Output Voltage

Application circuit item shows the basic application circuit with TS2508A adjustable output version. The external resistor sets the output voltage according to the following equation:

$$V_{OUT} = 0.8V \times \left(1 + \frac{R1}{R2} \right)$$

Table 1: Resistor select for output voltage setting

V _{OUT}	R2	R1
5V	1.3K	6.8K
	5.6K	30K
3.3V	1.5K	4.7K
	5.6K	18K
2.5V	2.2K	4.7K
	5.6K	12K
1.8V	1.2K	1.5K
1.5V	2.2K	2K
1.2V	2K	1K
1V	2K	0.5K

The R2 setting 5.6k that no load current can be reduce to under 4mA for EL CAP

Input Capacitor Selection

This capacitor should be located close to the IC using short leads and the voltage rating should be approximately 1.5 times the maximum input voltage. The RMS current rating requirement for the input capacitor of a buck regulator is approximately 1/2 the DC load current. A low ESR input capacitor sized for maximum RMS current must be used. A 220µF low ESR capacitor for most applications is sufficient

Output Capacitor Selection

The output capacitor is required to filter the output and provide regulator loop stability. The important capacitor parameters are; the 100KHz Equivalent Series Resistance (ESR), the RMS ripples current rating, voltage rating, and capacitance value. For the output capacitor, the ESR value is the most important parameter. The ESR can be calculated from the following formula.

$$V_{RIPPLE} = \Delta I_L \times ESR = 0.33A \times 130m\Omega = 43mV$$

An aluminum electrolytic capacitor's ESR value is related to the capacitance and its voltage rating. In most case, higher voltage electrolytic capacitors have lower ESR values. Most of the time, capacitors with much higher voltage ratings may be needed to provide the low ESR values required for low output ripple voltage. It is recommended to replace this low ESR capacitor by using a 330µF low ESR values < 130mΩ

Inductor Selection

For most designs, the operate with inductors of 12µH to 33µH. The inductor value can be derived from the following equation:

$$L = \frac{V_{OUT} \times (V_{IN} - V_{OUT})}{V_{IN} \times \Delta I_L \times f_L \times X}$$

Where is inductor Ripple Current. Large value inductors lower ripple current and small value inductors result in high ripple currents. Choose inductor ripple current approximately 15% of the maximum load current 3A, ΔIL=0.4A. The DC current rating of the inductor should be at least equal to the maximum load current plus half the ripple current to prevent core saturation (3A+0.2A).

Function Descriptions (Continue)

Layout Guidance

If you need low T_c & T_j or large PD (Power Dissipation), The dual SW pins (5&6) and Gnd pins (7&8) on the SOP-8 package are internally connected to die pad, The PCB layout should allow for maximum possible copper area at the SW pins.

1. Connect C3 to V_{CC} and Gnd pin as closely as possible to get good power filter effect.
2. Connect R3 to V_{CC} and OCSET pin as closely as possible.
3. Connect ground side of the C2 & D1 as closely as possible.

Electrical Characteristics Curve

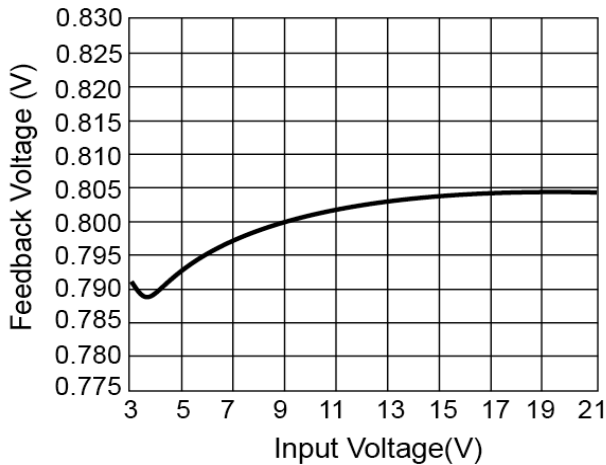

Figure 1. Feedback Voltage vs. Input Voltage

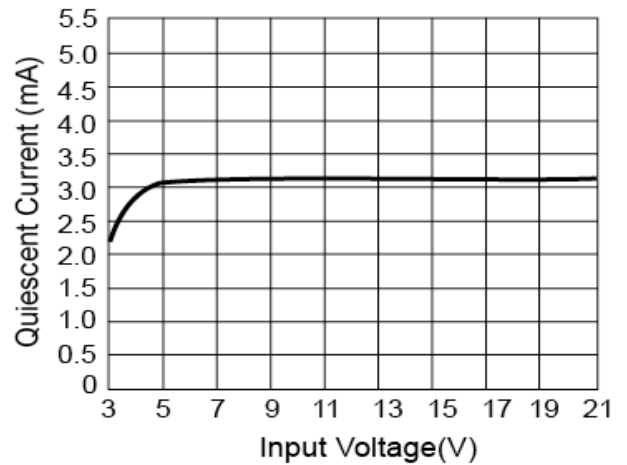

Figure 2. Quiescent Current vs. Input Voltage

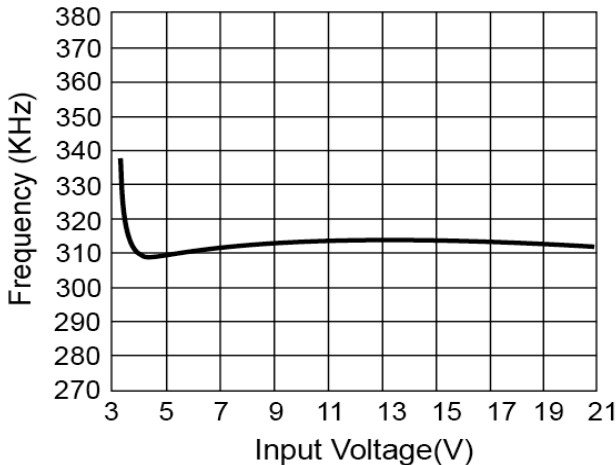

Figure 3. Frequency vs. Input Voltage

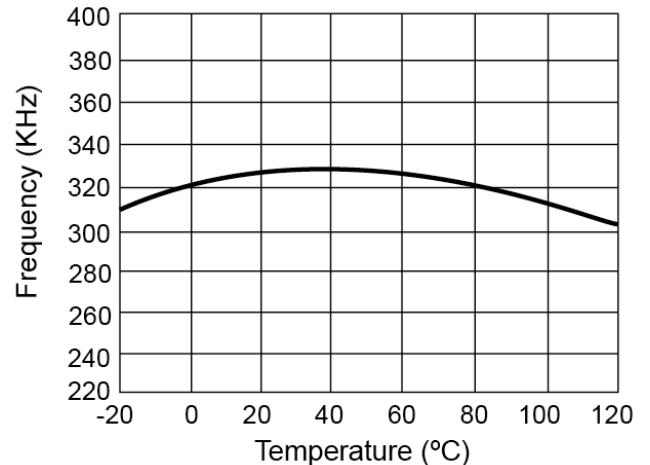

Figure 4. Frequency vs. Temperature

Electrical Characteristics Curve

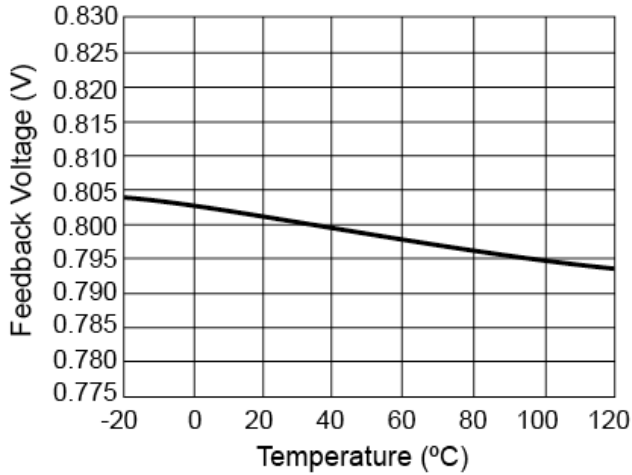

Figure 7. Feedback Voltage vs. Temperature

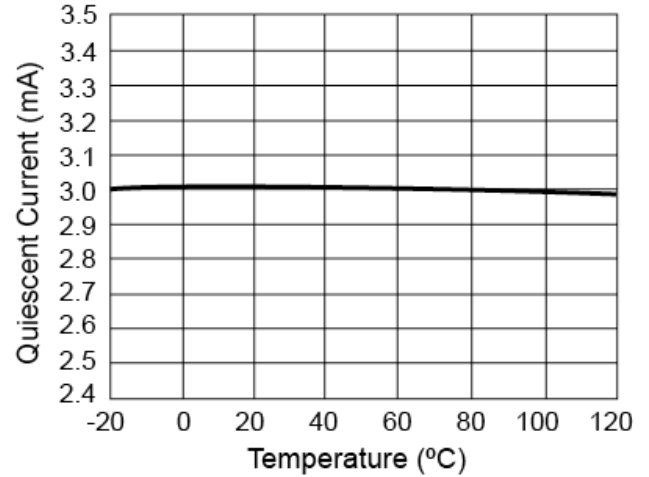

Figure 8. Quiescent Current vs. Temperature

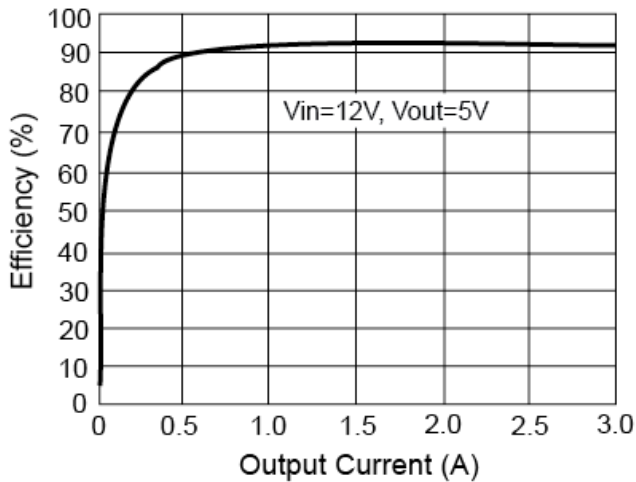

Figure 9. Efficiency vs. Output Current

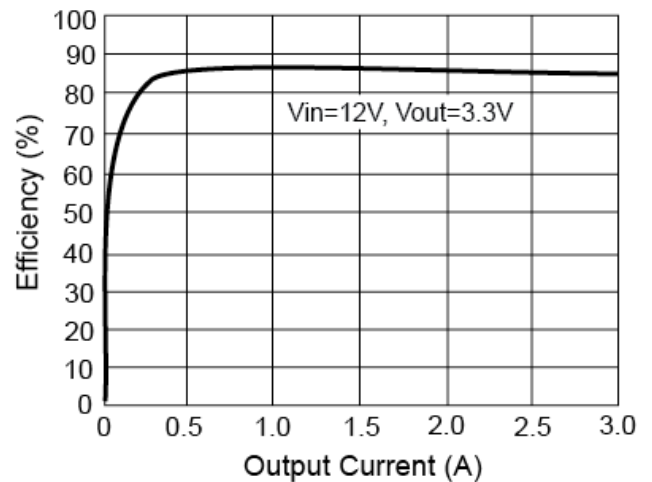
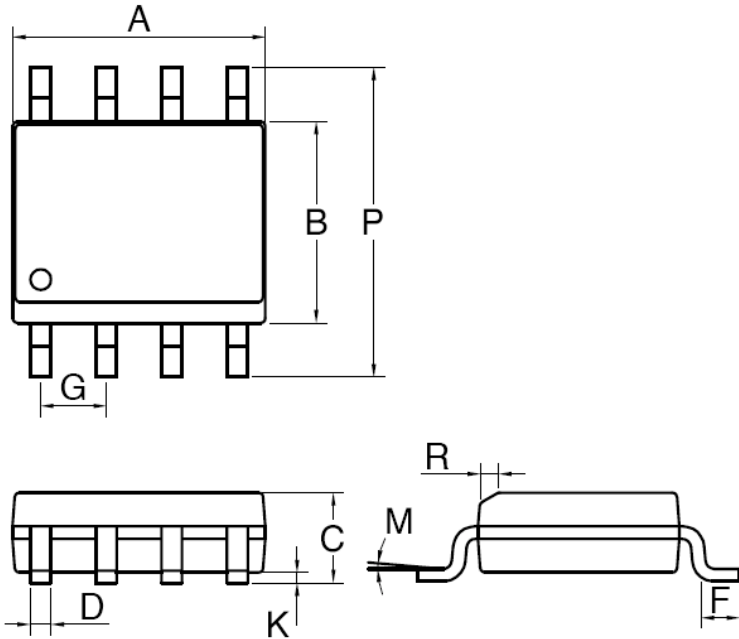

Figure 10. Efficiency vs. Output Current

SOP-8 Mechanical Drawing



DIM	MILLIMETERS		INCHES	
	MIN	MAX	MIN	MAX.
A	4.80	5.00	0.189	0.196
B	3.80	4.00	0.150	0.157
C	1.35	1.75	0.054	0.068
D	0.35	0.49	0.014	0.019
F	0.40	1.25	0.016	0.049
G	1.27BSC		0.05BSC	
K	0.10	0.25	0.004	0.009
M	0°	7°	0°	7°
P	5.80	6.20	0.229	0.244
R	0.25	0.50	0.010	0.019

Marking Diagram

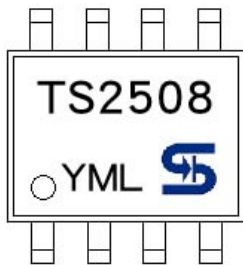

- Y** = Year Code
- M** = Month Code
(**A**=Jan, **B**=Feb, **C**=Mar, **D**=Apr, **E**=May, **F**=Jun, **G**=Jul, **H**=Aug, **I**=Sep, **J**=Oct, **K**=Nov, **L**=Dec)
- L** = Lot Code

Notice

Specifications of the products displayed herein are subject to change without notice. TSC or anyone on its behalf, assumes no responsibility or liability for any errors or inaccuracies.

Information contained herein is intended to provide a product description only. No license, express or implied, to any intellectual property rights is granted by this document. Except as provided in TSC's terms and conditions of sale for such products, TSC assumes no liability whatsoever, and disclaims any express or implied warranty, relating to sale and/or use of TSC products including liability or warranties relating to fitness for a particular purpose, merchantability, or infringement of any patent, copyright, or other intellectual property right.

The products shown herein are not designed for use in medical, life-saving, or life-sustaining applications. Customers using or selling these products for use in such applications do so at their own risk and agree to fully indemnify TSC for any damages resulting from such improper use or sale.