

A True 150-nA I_Q , 0.9-3.6V_{IN}, Selectable 1.8-5V_{OUT} Instant-On™ Boost Converter

FEATURES

- ◆ Ultra-Efficient Boost Converter:
 - Active Mode, No-load Supply Current: 150nA
 - Efficiency: Up to 92%
 - Input Voltage Range: 0.9V-3.6V
 - Delivers up to 35mA at 3V_{STORE} from 1.2V_{IN}
 - Single-inductor, Discontinuous Conduction Mode Operation
 - No External Schottky Diode Required
- ◆ Pin-Selectable Output Voltages: 1.8V, 2.1V, 2.5V, 2.85V, 3V, 3.3V, 4.1V, and 5V
- ◆ User-enabled Secondary Output Load Switch
- ◆ 10-Pin, Low-Profile, 2mm x 2mm TDFN Package

APPLICATIONS

- Coin Cell-Powered Portable Equipment
- Single Cell Li-ion or Alkaline Powered Equipment
- Solar or Mechanical Energy Harvesting
- Wireless Microphones
- Wireless Remote Sensors
- RFID Tags
- Blood Glucose Meters
- Personal Health-Monitoring Devices
- ZigBee Radio Enabled Devices
- Low-Energy Bluetooth Radio Enabled Devices

DESCRIPTION

The TS3310 is a low power boost switching regulator with an industry leading low quiescent current of 150nA. The 150nA is the actual current consumed from the battery while the output is in regulation. The TS3310's extremely low power internal circuitry consumes 90nA on average, with periodic switching cycles which service the load occurring at intervals of up to 25 seconds, together yielding the average 150nA. The TS3310 steps up input voltages from 0.9V to 3.6V to eight selectable output voltages ranging from 1.8V to 5V. The TS3310 includes two output options, one being an always-on storage output while the additional output is an output load switch that is designed to supply burst-on loads in a low duty cycle manner. The TS3310 operates in Discontinuous Conduction Mode with an on-time proportional to $1/V_{IN}$, thereby limiting the maximum input current by the selection of the inductor value, ensuring the input current does not drag down the input source.

The extremely low quiescent current combined with the output load switch make the TS3310 an ideal choice for applications where the load can be periodically powered from the output, while being disconnected from the output storage capacitor when the load is powered off to isolate the load's leakage current.

The TS3310 is fully specified over the -40°C to +85°C temperature range and is available in a low-profile, thermally-enhanced 10-pin 2x2mm TDFN package with an exposed back-side paddle.

TYPICAL APPLICATION CIRCUIT

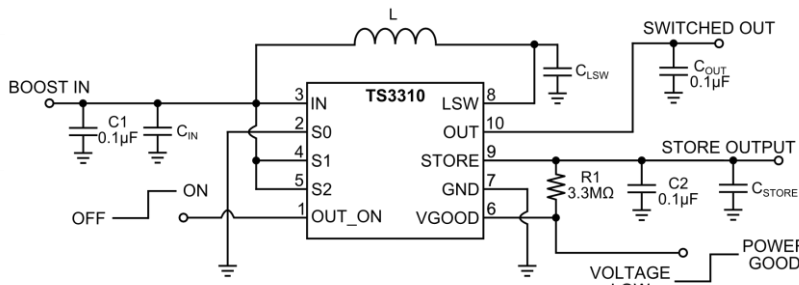

	Circuit A	Circuit B
L	10μH PN: CBC3225T100KR	100μH PN: CBC3225T101KR
C_{IN} = C_{STORE}	10μF	1μF
C_{LSW}	220pF	---

Efficiency vs STORE Current
IN=1.2V, STORE=3V

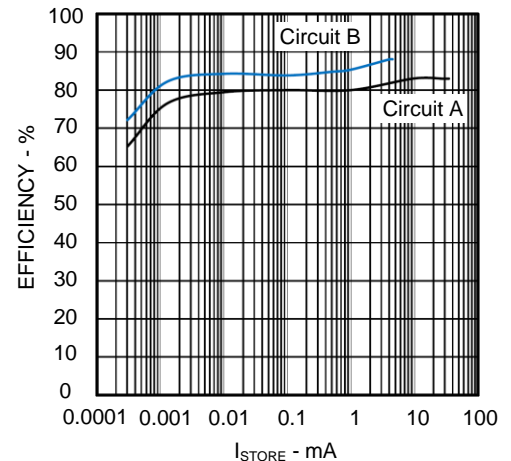

The Touchstone Semiconductor logo and "NanoWatt Analog" are registered trademarks of Touchstone Semiconductor, Incorporated.

ABSOLUTE MAXIMUM RATINGS

IN to GND.....-0.3V to +6.0V
 STORE to GND.....-0.3V to +6.0V
 OUT to GND.....-0.3V to +6.0V
 LSW to GND.....-0.3V to +6.0V
 OUT_ON, S0, S1, S2 to GND.....-0.3V to +6.0V
 VGOOD to GND.....-0.3V to +6.0V

Continuous Power Dissipation (T_A = +70°C)
 10-Pin TDFN22EP (Derate at 13.48mW/°C above +70°C) 1078mW
 Operating Temperature Range..... -40°C to +85°C
 Junction Temperature +150°C
 Storage Temperature Range..... -65°C to +150°C
 Lead Temperature (Soldering, 10s)..... +300°C

Electrical and thermal stresses beyond those listed under “Absolute Maximum Ratings” may cause permanent damage to the device. These are stress ratings only and functional operation of the device at these or any other condition beyond those indicated in the operational sections of the specifications is not implied. Exposure to any absolute maximum rating conditions for extended periods may affect device reliability and lifetime.

PACKAGE/ORDERING INFORMATION

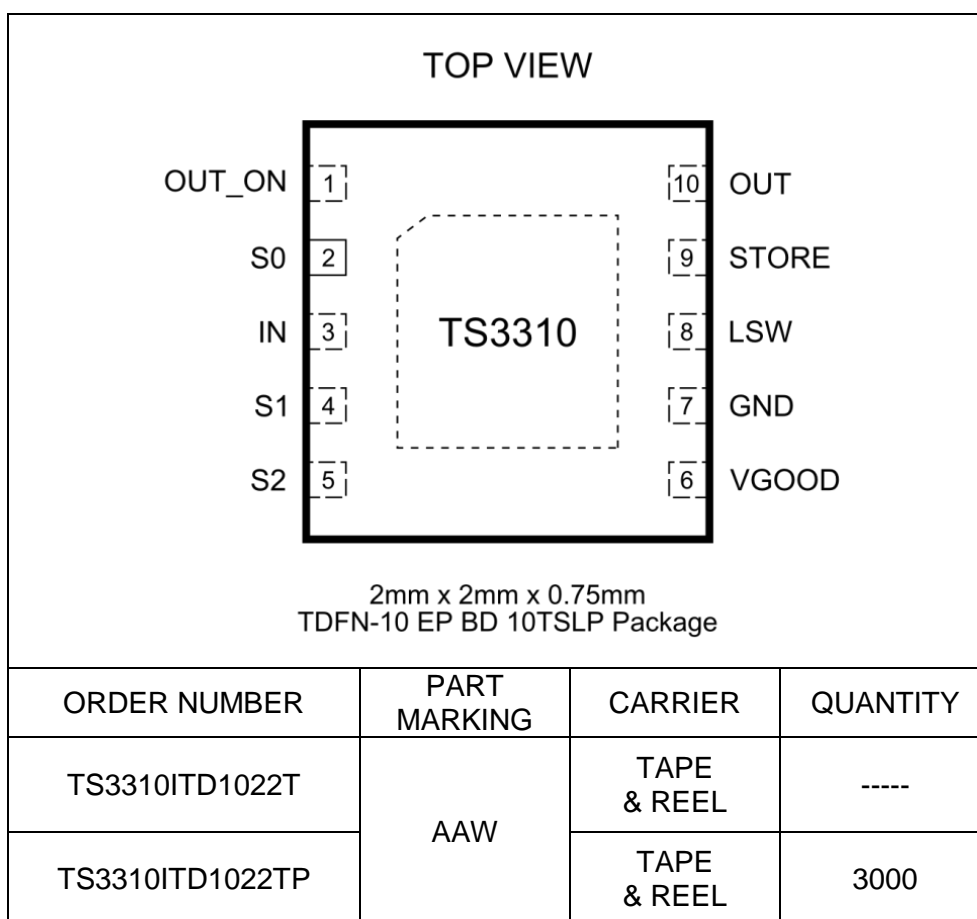

Lead-free Program: Touchstone Semiconductor supplies only lead-free packaging.

Consult Touchstone Semiconductor for products specified with wider operating temperature ranges.

ELECTRICAL CHARACTERISTICS

$V_{IN}=1.2V$, $V_{OUT_ON}=V_{IN}$, V_{PROG} is the programmed voltage according to S2, S1, S0 pins set for STORE voltage of 3V unless otherwise specified. $T_A=-40^{\circ}C$ to $85^{\circ}C$. Typical values are at $T_A=+25^{\circ}C$ unless otherwise specified. Please see Note 1.

PARAMETER	SYMBOL	CONDITIONS	MIN	TYP	MAX	UNITS	
Input Voltage Range	V_{IN}		0.9		3.6	V	
Under Voltage Lock Out	UVLO			0.855	0.9	V	
	Hysteresis			20		mV	
STORE Voltage	V_{STORE}	$I_{STORE}=50\%$ of $I_{STORE(MAX)}$, $0.9V < V_{IN} < 3.6V$, at any $V_{PROG} > V_{IN}$. $T_A=+25^{\circ}C$. See Note 2.	$0.97 \times V_{PROG}$	V_{PROG}	$1.03 \times V_{PROG}$	V	
V_{PROG} Tempco				0.027		% / $^{\circ}C$	
No-Load Input Current, I_Q	I-Floor	@ IN. See Note 3.		90	180	nA	
		@ STORE. See Note 3.		30			
	Active-Mode	@ IN. See Note 4.		150			
Boost Switch On-Time	T_{ON}	$V_{IN}=1.8V$	$0.8 \times 2/V_{IN}$	$2/V_{IN}$	$1.2 \times 2/V_{IN}$	μ sec	
On Resistance	NMOS	R_{ON} NMOS	$V_{STORE}=1.8V$		0.8	1.3	Ω
	PMOS	R_{ON} PMOS			1.1	1.65	
	LOAD SWITCH	R_{ON} LOAD SWITCH			1.1	1.65	
	NMOS	R_{ON} NMOS	$V_{STORE}=3V$		500		m Ω
	PMOS	R_{ON} PMOS			650		
	LOAD SWITCH	R_{ON} LOAD SWITCH			650		
V_{STORE} GOOD	V_{VGOOD}	% of target STORE voltage	80	90	95	%	
	Hysteresis			5			
V_{OUT_ON} Input Voltage	$V_{OUT_ON L}$	Low CMOS Logic Level			0.2	V	
	$V_{OUT_ON H}$	High CMOS Logic Level	0.6				
S0, S1, S2 Input Voltage	S0L, S1L, S2L	Low CMOS Logic Level			0.2	V	
	S0H, S1H, S2H	High CMOS Logic Level	0.6				
S0, S1, S2, OUT_ON Input Leakage Current				5		nA	

Note 1: All devices are 100% production tested at $T_A = +25^{\circ}C$ and are guaranteed by characterization for $T_A = -40^{\circ}C$ to $+85^{\circ}C$, as specified.

Note 2: $I_{STORE(MAX)}$ is provided as the Maximum Average STORE Current by the graph entitled "Expected Maximum STORE Output Current" in the TS3310 Applications Section.

Note 3: V_{STORE} output is driven above regulation point. No switching is occurring.

Note 4: $V_{STORE}=3V$. $L=100\mu H$. $C_{STORE}=1\mu F$.

TYPICAL PERFORMANCE CHARACTERISTICS

$V_{OUT_ON}=GND$, $V_{VGOOD}=GND$, $C_{OUT}=C_1=C_2=0.1\mu F$, $I_{STORE}=0A$, $I_{OUT}=0A$ unless otherwise specified. Values are at $T_A=25^\circ C$ unless otherwise specified.

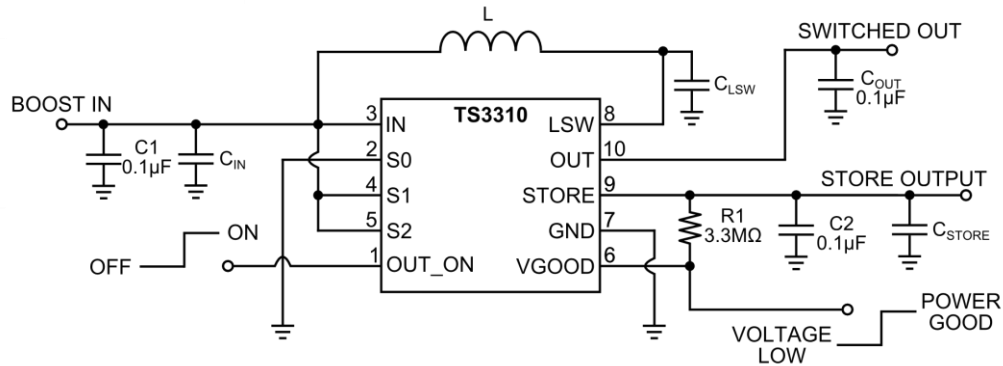

	Circuit A	Circuit B
L	10 μ H PN: CBC3225T100KR	100 μ H PN: CBC3225T101KR
$C_{IN}=C_{STORE}$	10 μ F	1 μ F
C_{LSW}	220pF	---

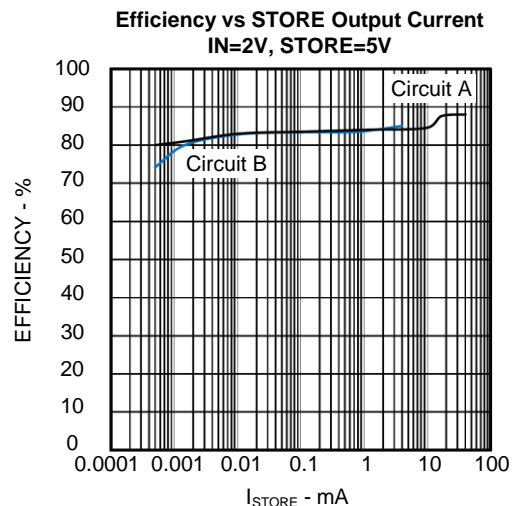
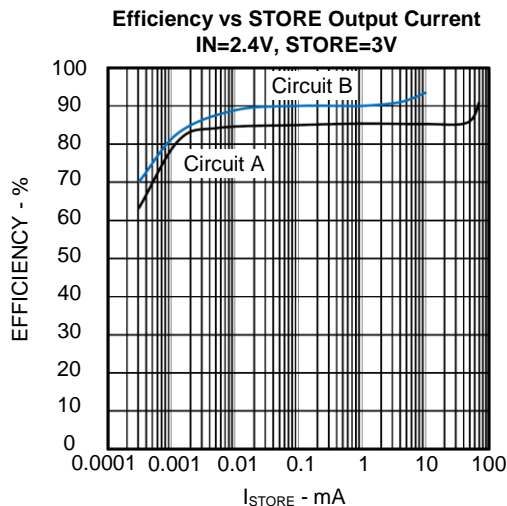
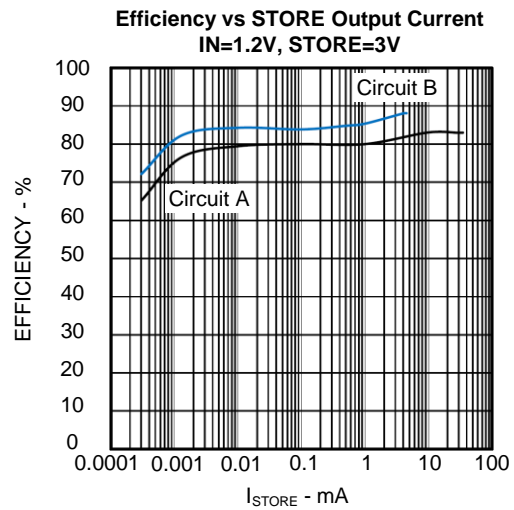
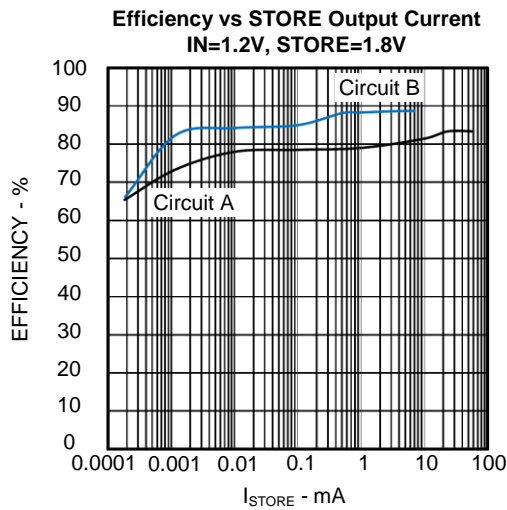

TYPICAL PERFORMANCE CHARACTERISTICS

$V_{OUT_ON}=GND$, $V_{VGOOD}=GND$, $C_{OUT}=C_1=C_2=0.1\mu F$, $I_{STORE}=0A$, $I_{OUT}=0A$ unless otherwise specified. Values are at $T_A=25^\circ C$ unless otherwise specified.

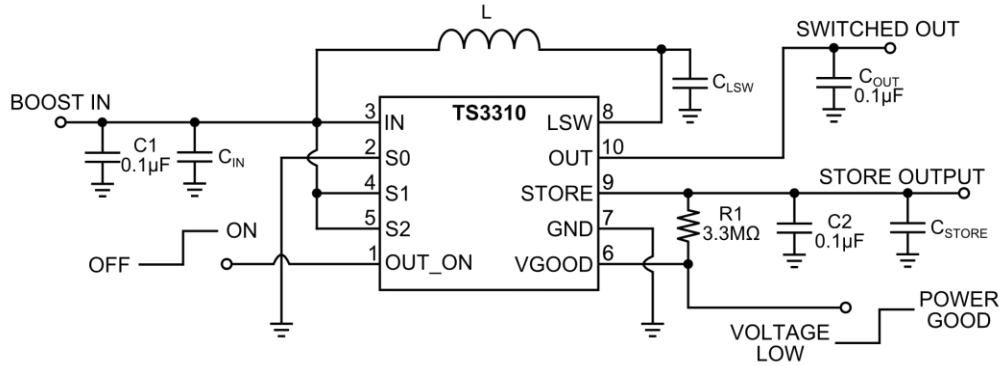

	Circuit A	Circuit B
L	10µH PN: CBC3225T100KR	100µH PN: CBC3225T101KR
$C_{IN}=C_{STORE}$	10µF	1µF
C_{LSW}	220pF	---

Efficiency vs STORE Output Current
IN=3V, STORE=5V

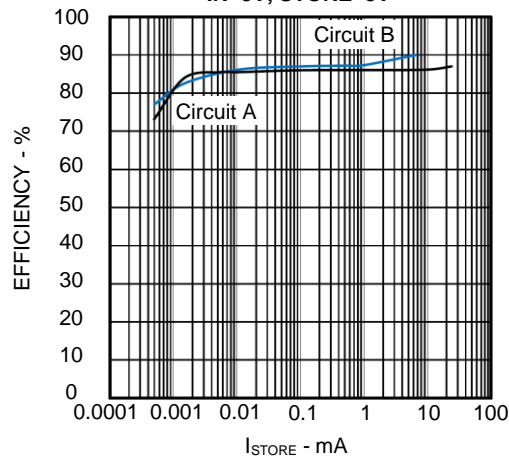

Active-Mode I_q vs Input Voltage
with No Load : Circuit A (STORE=1.8V)

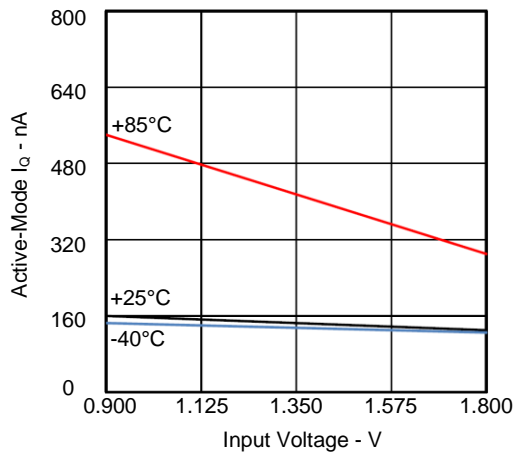

Active-Mode I_q vs Input Voltage
with No Load : Circuit B (STORE=1.8V)

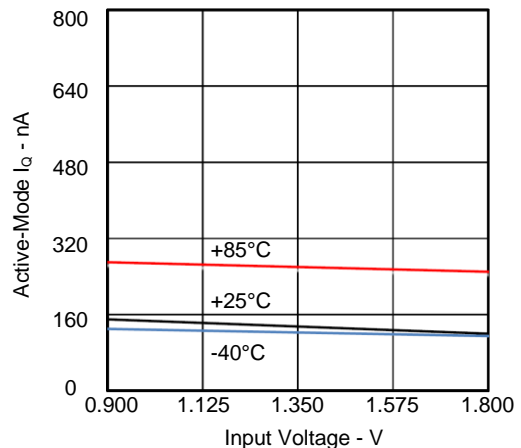

TYPICAL PERFORMANCE CHARACTERISTICS

$V_{OUT_ON}=GND$, $V_{VGOOD}=GND$, $C_{OUT}=C1=C2=0.1\mu F$, $I_{STORE}=0A$, $I_{OUT}=0A$ unless otherwise specified. Values are at $T_A=25^\circ C$ unless otherwise specified.

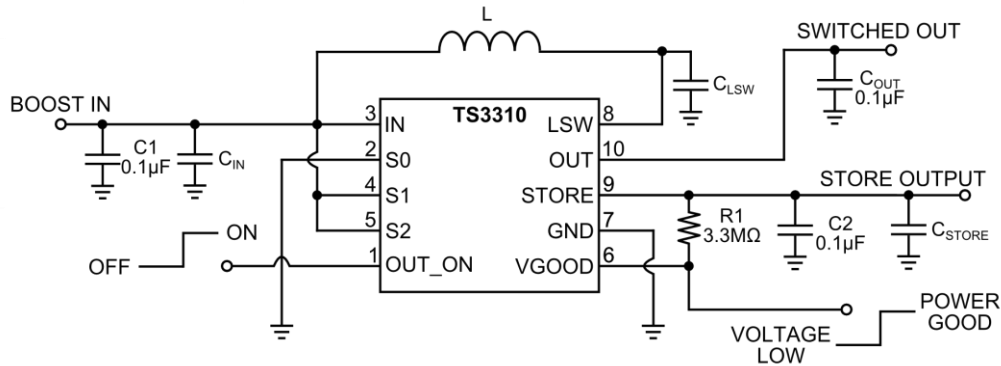

	Circuit A	Circuit B
L	10µH PN: CBC3225T100KR	100µH PN: CBC3225T101KR
$C_{IN}=C_{STORE}$	10µF	1µF
C_{LSW}	220pF	---

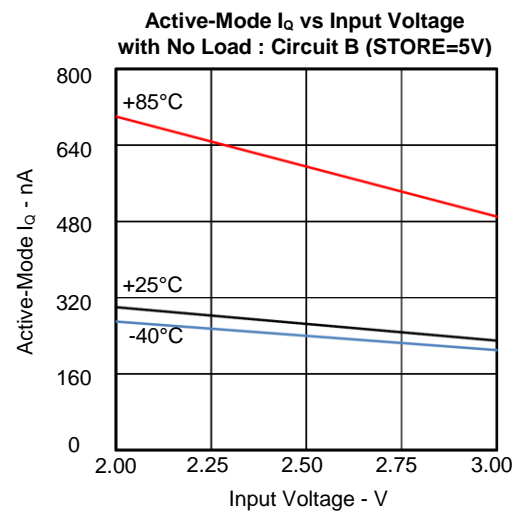
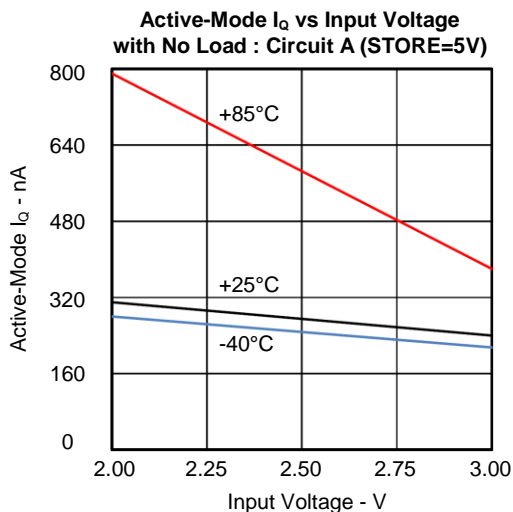
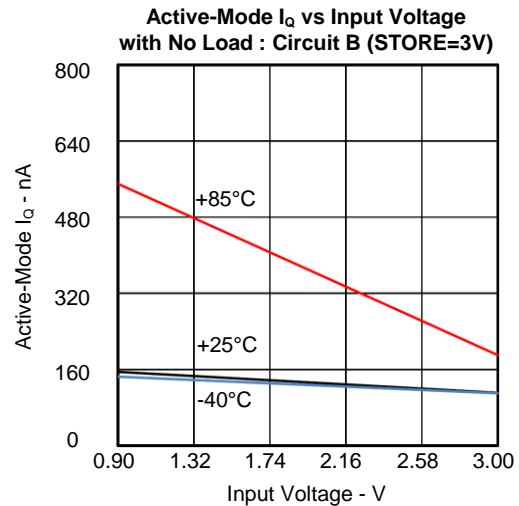
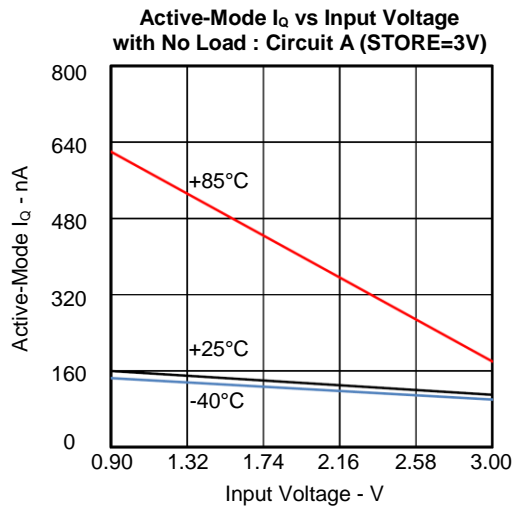

TYPICAL PERFORMANCE CHARACTERISTICS

$V_{OUT_ON}=GND$, $V_{VGOOD}=GND$, $C_{OUT}=C_1=C_2=0.1\mu F$, $I_{STORE}=0A$, $I_{OUT}=0A$ unless otherwise specified. Values are at $T_A=25^\circ C$ unless otherwise specified.

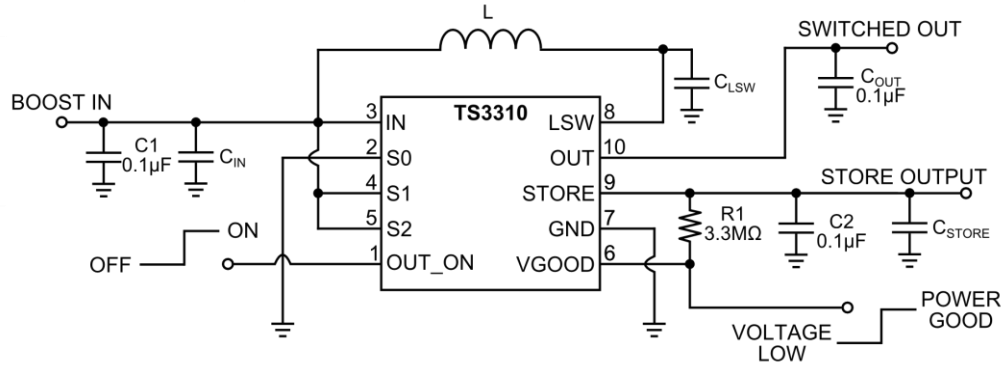

	Circuit A	Circuit B
L	10µH PN: CBC3225T100KR	100µH PN: CBC3225T101KR
$C_{IN}=C_{STORE}$	10µF	1µF
C_{LSW}	220pF	---

Minimum Start-Up Voltage vs STORE Output Current
Circuit A with 10Ω Source Resistance (STORE=1.8V)

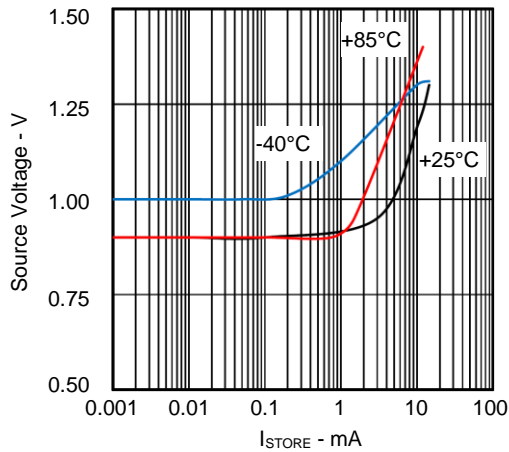

Minimum Start-Up Voltage vs STORE Output Current
Circuit B with 10Ω Source Resistance (STORE=1.8V)

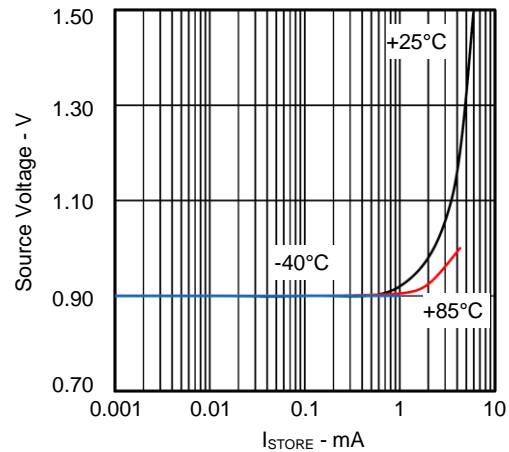

Minimum Start-Up Voltage vs STORE Output Current
Circuit A with 10Ω Source Resistance (STORE=3V)

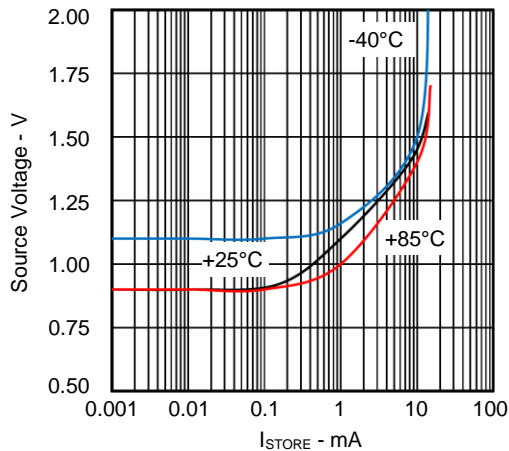

Minimum Start-Up Voltage vs STORE Output Current
Circuit B with 10Ω Source Resistance (STORE=3V)

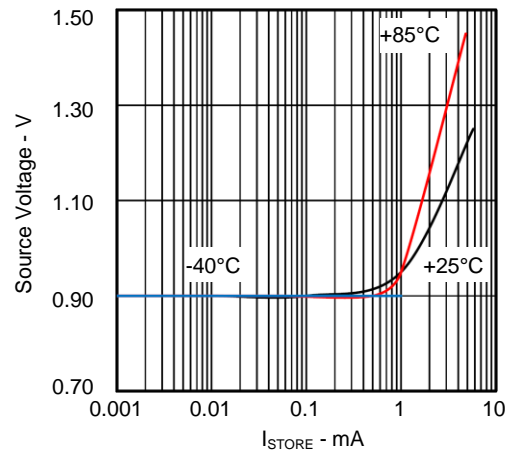

TYPICAL PERFORMANCE CHARACTERISTICS

$V_{OUT_ON}=GND$, $V_{VG_GOOD}=GND$, $C_{OUT}=C_1=C_2=0.1\mu F$, $I_{STORE}=0A$, $I_{OUT}=0A$ unless otherwise specified. Values are at $T_A=25^\circ C$ unless otherwise specified.

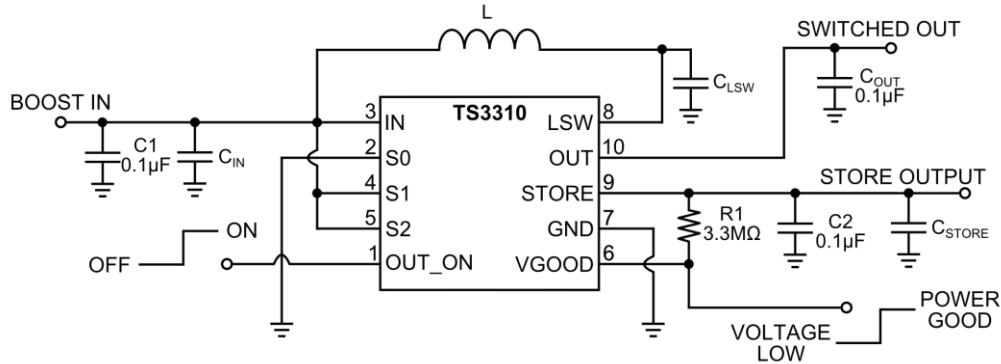

	Circuit A	Circuit B
L	10µH PN: CBC3225T100KR	100µH PN: CBC3225T101KR
$C_{IN}=C_{STORE}$	10µF	1µF
C_{LSW}	220pF	---

Minimum Start-Up Voltage vs STORE Output Current
Circuit A with 10Ω Source Resistance (STORE=5V)

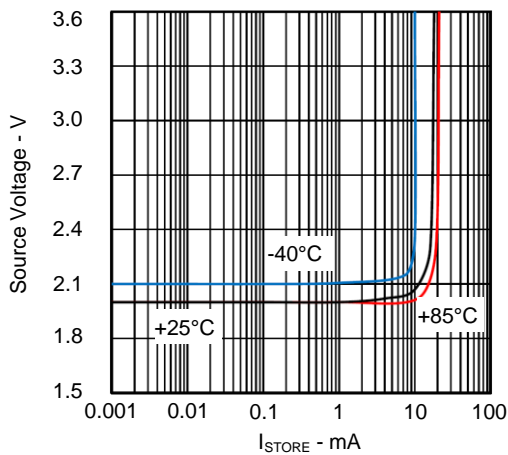

Minimum Start-Up Voltage vs STORE Output Current
Circuit B with 10Ω Source Resistance (STORE=5V)

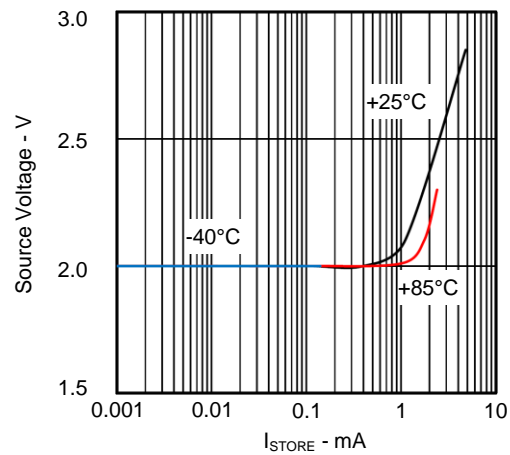

Minimum Start-Up Voltage
vs Source Resistance : $V_{STORE}=1.8V$

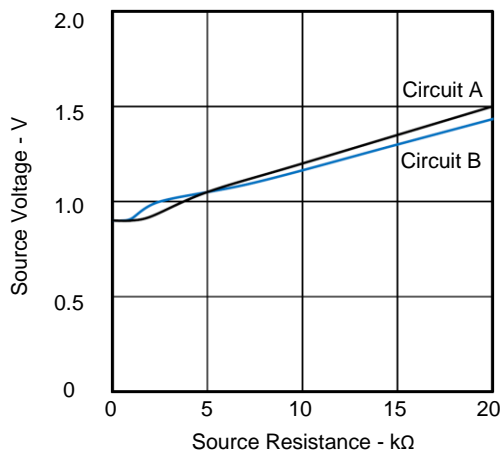

Minimum Start-Up Voltage
vs Source Resistance : $V_{STORE}=3V$

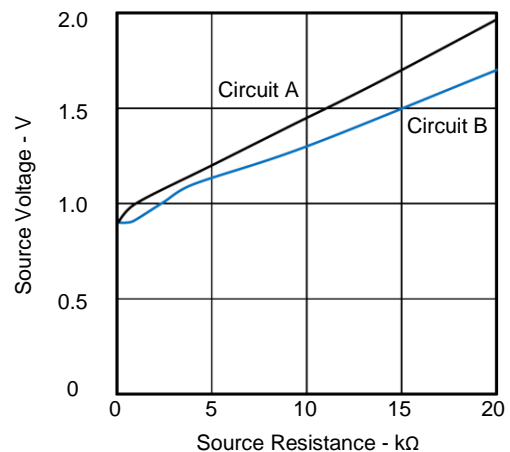

TYPICAL PERFORMANCE CHARACTERISTICS

$V_{OUT_ON}=GND$, $V_{VGOOD}=GND$, $C_{OUT}=C_1=C_2=0.1\mu F$, $I_{STORE}=0A$, $I_{OUT}=0A$ unless otherwise specified. Values are at $T_A=25^\circ C$ unless otherwise specified.

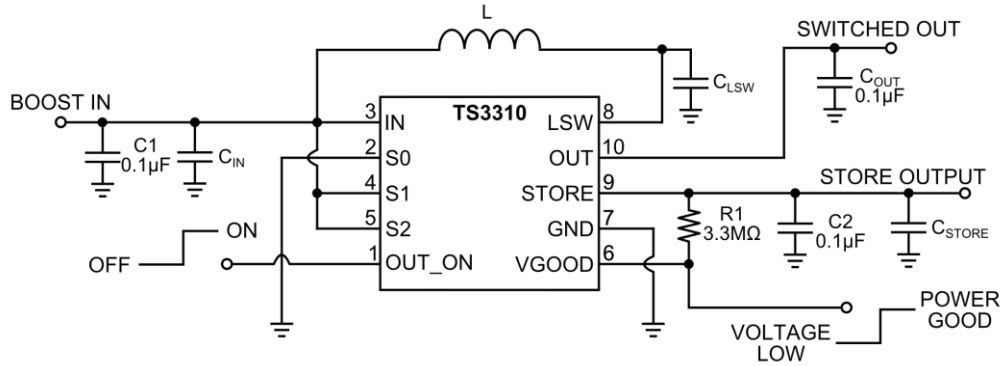

	Circuit A	Circuit B
L	10µH PN: CBC3225T100KR	100µH PN: CBC3225T101KR
$C_{IN}=C_{STORE}$	10µF	1µF
C_{LSW}	220pF	---

Maximum STORE Output Current vs Input Voltage
w/ $V_{STORE} \geq 96\%$ of Target Voltage : Circuit A

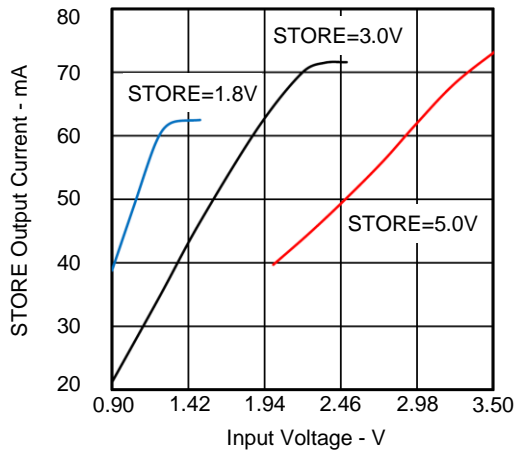

Maximum STORE Output Current vs Input Voltage
w/ $V_{STORE} \geq 96\%$ of Target Voltage : Circuit B

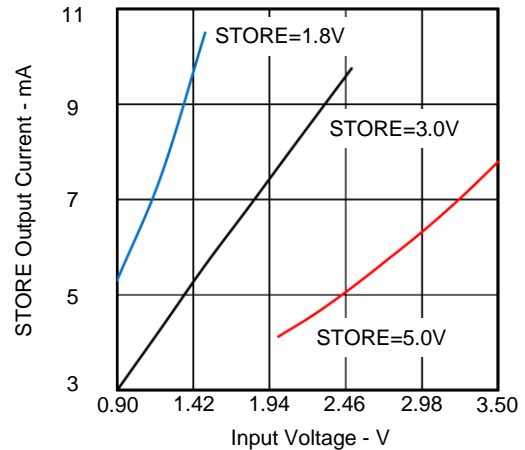

Active-Mode I_Q : Circuit A with No-Load
 $V_{IN}=1.2V$, STORE=3V

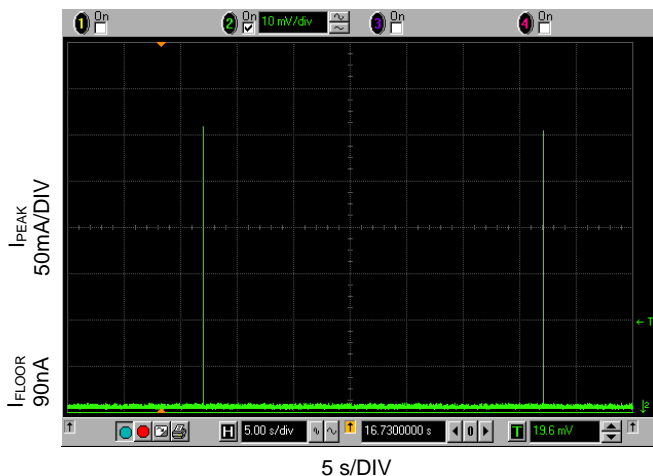

Active-Mode I_Q : Circuit A with No-Load
 $V_{IN}=3V$, STORE=3V

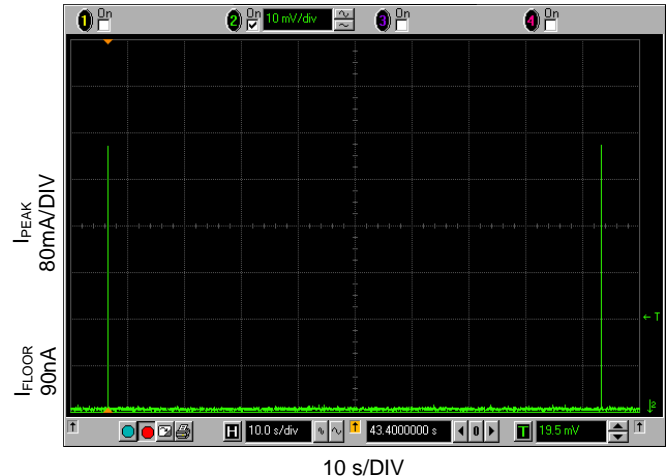

TYPICAL PERFORMANCE CHARACTERISTICS

$V_{OUT_ON}=GND$, $V_{VGOOD}=GND$, $C_{OUT}=C_1=C_2=0.1\mu F$, $I_{STORE}=0A$, $I_{OUT}=0A$ unless otherwise specified. Values are at $T_A=25^\circ C$ unless otherwise specified.

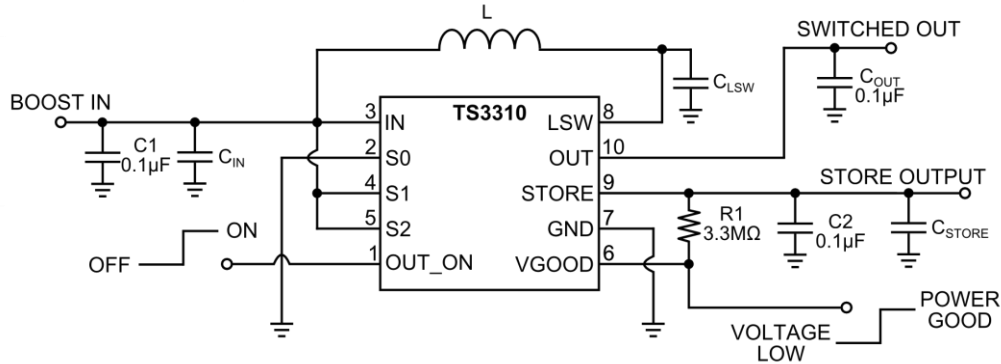

	Circuit A	Circuit B
L	10µH PN: CBC3225T100KR	100µH PN: CBC3225T101KR
$C_{IN}=C_{STORE}$	10µF	1µF
C_{LSW}	220pF	---

STORE Load Step Response : Circuit A
 $V_{IN}=1.2V$, STORE=3V, $I_{STORE}=24mA$

STORE Load Step Response : Circuit B
 $V_{IN}=1.2V$, STORE=3V, $I_{STORE}=3mA$

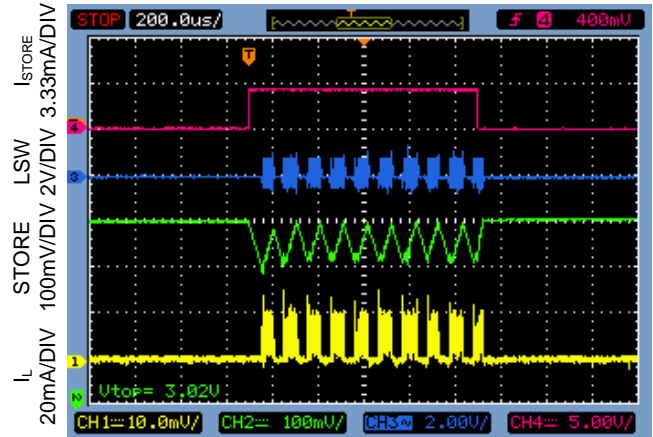
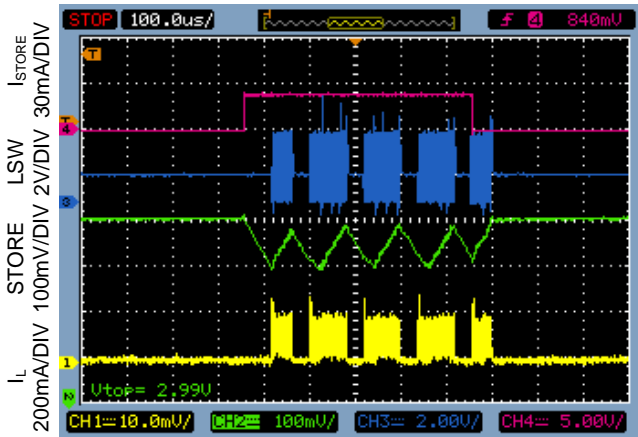

STORE Output Voltage Ripple, Inductor Current, and LSW Voltage : Circuit A
 $V_{IN}=1.2V$, STORE=3V, $I_{STORE}=10mA$

STORE Output Voltage Ripple, Inductor Current, and LSW Voltage : Circuit A
 $V_{IN}=1.2V$, STORE=3V, $I_{STORE(MAX)}=35mA$

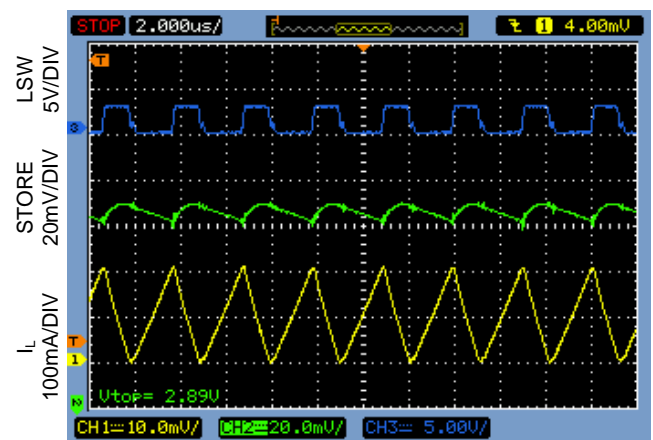
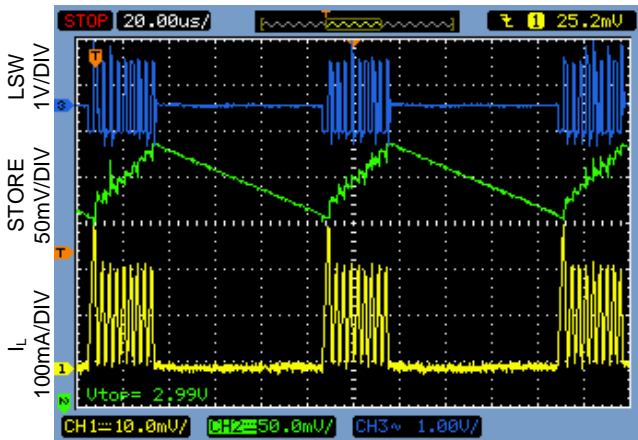

TYPICAL PERFORMANCE CHARACTERISTICS

$V_{OUT_ON}=GND$, $V_{VGOOD}=GND$, $C_{OUT}=C_1=C_2=0.1\mu F$, $I_{STORE}=0A$, $I_{OUT}=0A$ unless otherwise specified. Values are at $T_A=25^\circ C$ unless otherwise specified.

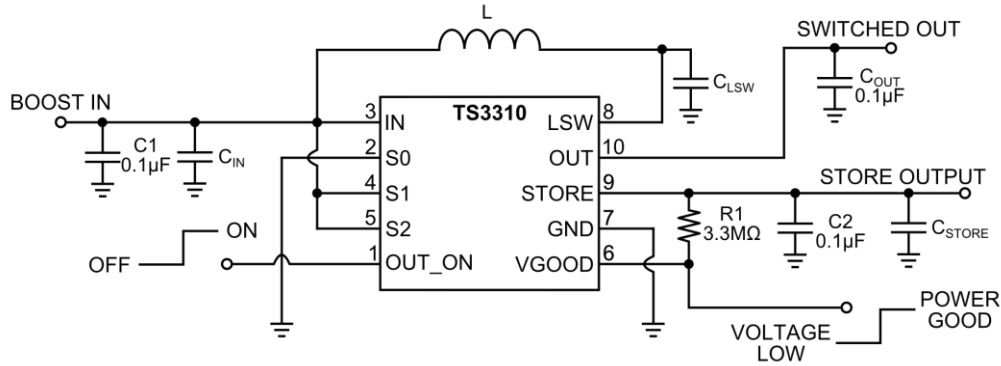

	Circuit A	Circuit B
L	10µH PN: CBC3225T100KR	100µH PN: CBC3225T101KR
$C_{IN}=C_{STORE}$	10µF	1µF
C_{LSW}	220pF	---

Startup : Circuit A with $R_{IN}=10\Omega$
 $V_{IN}=0.9V$, $STORE=1.8V$, $I_{STORE}=0.18\mu A$

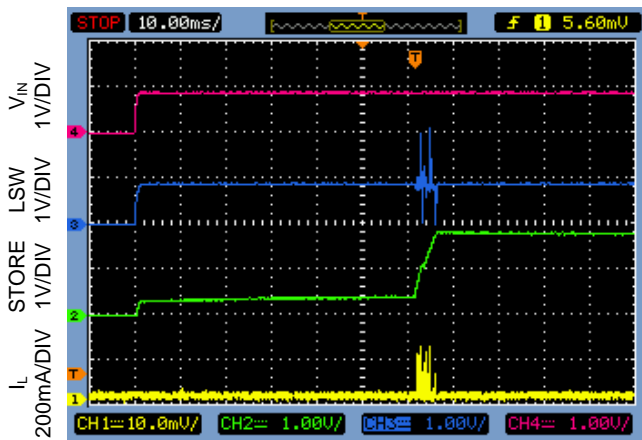

Startup : Circuit A with $R_{IN}=10\Omega$
 $V_{IN}=2V$, $STORE=5V$, $I_{STORE}=0.5\mu A$

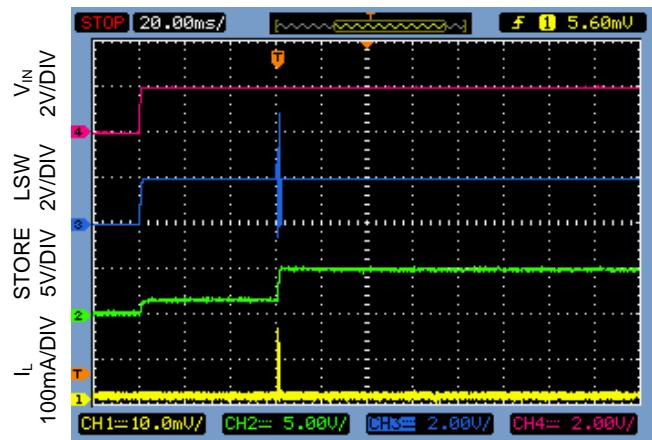

Startup : Circuit A with $R_{IN}=10\Omega$
 $V_{IN}=1.2V$, $STORE=1.8V$, $I_{STORE}=10mA$

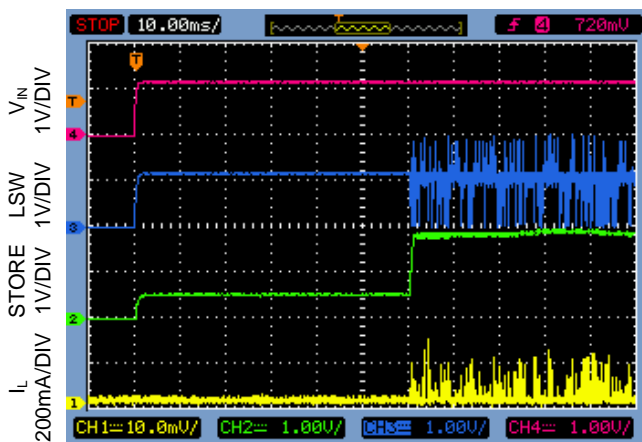

Startup : Circuit A with $R_{IN}=10\Omega$
 $V_{IN}=2V$, $STORE=5V$, $I_{STORE}=10mA$

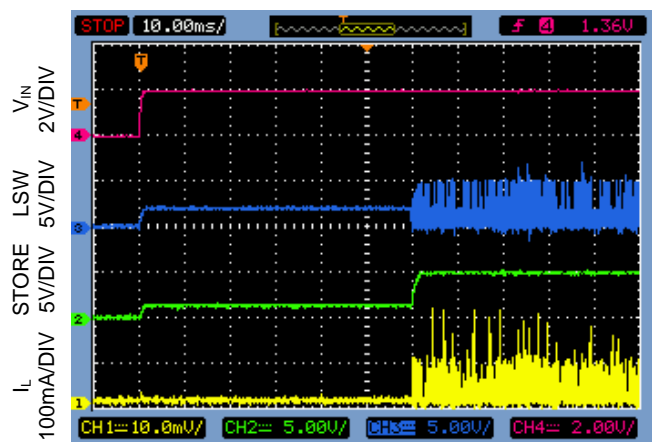

TYPICAL PERFORMANCE CHARACTERISTICS

$V_{OUT_ON}=GND$, $V_{VGOOD}=GND$, $C_{OUT}=C_1=C_2=0.1\mu F$, $I_{STORE}=0A$, $I_{OUT}=0A$ unless otherwise specified. Values are at $T_A=25^\circ C$ unless otherwise specified.

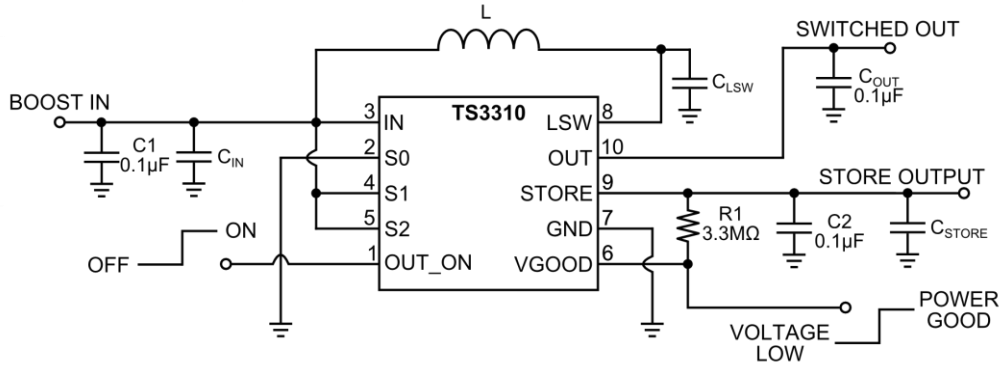

	Circuit A	Circuit B
L	10µH PN: CBC3225T100KR	100µH PN: CBC3225T101KR
$C_{IN}=C_{STORE}$	10µF	1µF
C_{LSW}	220pF	---

Short STORE to GND for 1msec Recovery : Circuit A
 $V_{IN}=1.2V$, $STORE=3V$, $I_{STORE}=9mA$

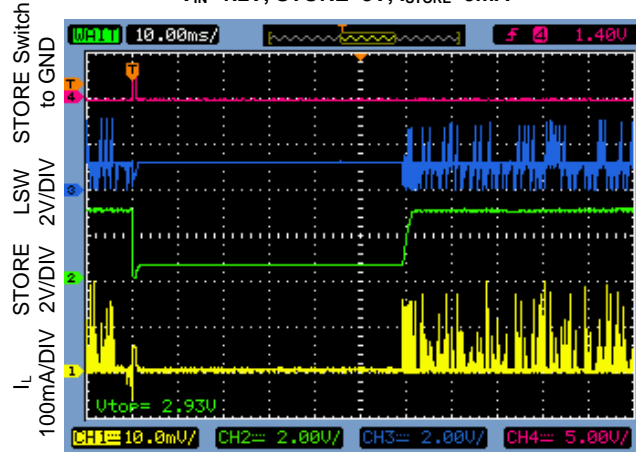

OUT_ON Switched ON : Circuit A with C_{OUT} Removed
 $V_{IN}=1.2V$, $STORE=3V$, $I_{STORE}=0.3\mu A$, $I_{OUT}=3mA$

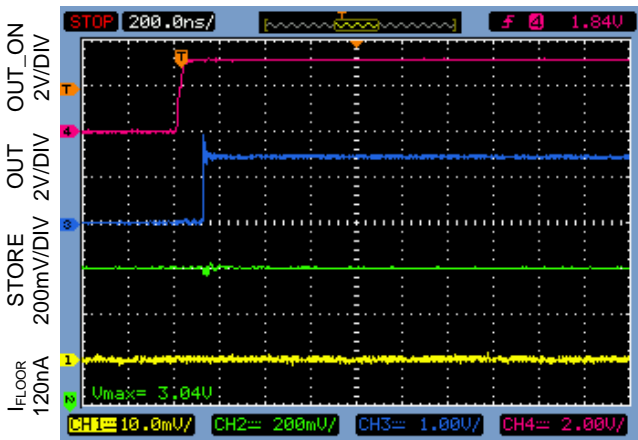

OUT_ON Switched OFF : Circuit A with C_{OUT} Removed
 $V_{IN}=1.2V$, $STORE=3V$, $I_{STORE}=0.3\mu A$, $I_{OUT}=3mA$

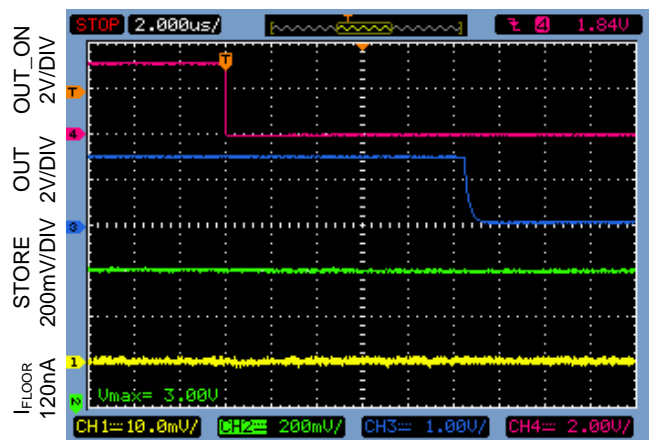

PIN FUNCTIONS

PIN	NAME	FUNCTION
1	OUT_ON	Logic Input. Turns on OUT switch.
2	IN	Boost Input. Connect to input source.
3	S0	Logic Input. Sets the regulated voltage at STORE.
4	S1	Logic Input. Sets the regulated voltage at STORE.
5	S2	Logic Input. Sets the regulated voltage at STORE.
6	VGOOD	Open Drain Output. High impedance when STORE > 90% of regulation voltage.
7	GND	Ground. Connect this pin to the analog ground plane.
8	LSW	Inductor Connection. If using an inductor value $\leq 22\mu\text{H}$, please see Table 3 for recommended C_{LSW} values.
9	STORE	Regulated output voltage set by S0, S1, S2 logic. Connect Storage capacitor.
10	OUT	Switched Output.

BLOCK DIAGRAM

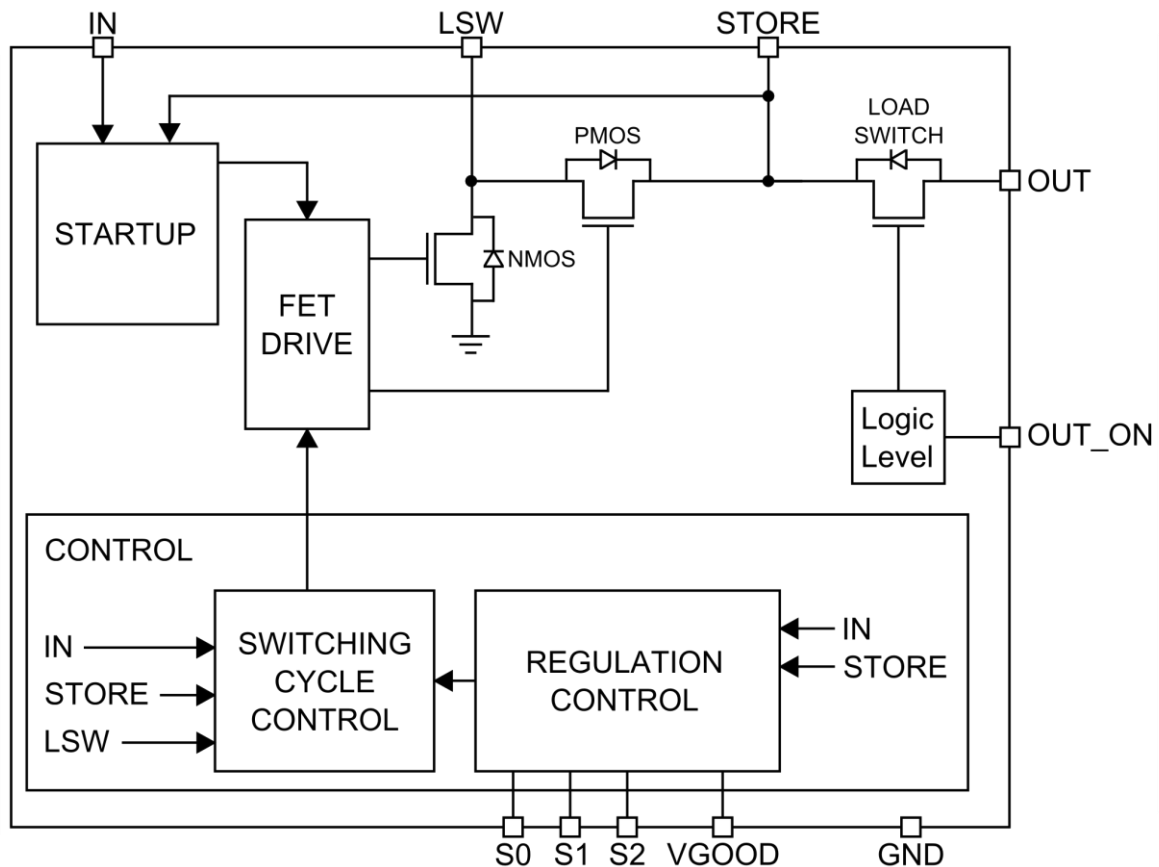

THEORY OF OPERATION

The TS3310 is a boost switching regulator with an industry leading low quiescent current of 150nA. The 150nA is the actual current consumed from the battery while the output is in regulation. The TS3310's extremely low power internal circuitry consumes 90nA on average, with periodic switching cycles which service the load occurring at intervals of up to 25 seconds, as displayed in the scope capture entitled "Input Quiescent Current : Circuit A with No-Load" on Page 9. The always-on output voltage at STORE is regulated by a comparator within the Regulation Control block. When a load discharges C_{STORE} and causes the output voltage to drop below the desired regulated voltage, switching periods are initiated. When the output voltage is at or above the desired regulated voltage, the comparator causes switching periods to stop.

Each switching cycle includes an ON period and an OFF period. During the ON period, the NMOS switch turns on to ramp current in the inductor, while during the OFF period, the NMOS switch turns off and the PMOS switch turns on to discharge inductor current into the C_{STORE} capacitor. When the ON and OFF cycles have completed, the PMOS switch turns off. The TS3310 operates in Discontinuous Conduction Mode (DCM); during any given switching cycle, the inductor current starts at and returns to zero. The switching cycle timing is governed by the Control block, which determines the ON and OFF periods according to the input and output voltages, regardless of the inductor current. The Control block sets the ON period according to:

$$t_{ON} = \frac{2\mu s \cdot V}{V_{IN}}$$

Equation 1. ON Period Calculation

The choice of the inductor value, then, determines the peak switching currents:

$$I_{pk} = \frac{V_{IN} \times t_{ON}}{L} = \frac{2\mu s \cdot V}{L}$$

Equation 2. Peak-Current Calculation

The average input current, I_{IN(AVG)}, will vary according to the load, since as the load is increased, the time between switching cycles is decreased. However, I_{IN(AVG)} will never exceed I_{IN(AVG,MAX)}, the maximum averaged input current, which represents

the case where switching periods are continuously initiated.

$$I_{IN(AVG,MAX)} = \frac{I_{pk}}{2} = \frac{1\mu s \cdot V}{L}$$

Equation 3. Maximum Average Input Current Calculation

Equation 3 shows that an input current limit can be set by choice of inductor value, set appropriately for the capacity and output impedance of the input source.

Maximum available output current is also a function of inductor value for the case where switching cycles are continuously initiated, the expected maximum STORE output current is:

$$I_{STORE(MAX)} = \frac{V_{IN}}{V_{OUT}} \times I_{IN(AVG,MAX)} \times \text{Eff}$$

Equation 4. Expected Maximum STORE Current Calculation

The Regulation Controls within the Control block monitor and control the regulation of the STORE output voltage. By strapping a combination of logic input pins (S0-S2) high or low, the STORE output voltage can be one of 8 selectable output voltages. For 5V STORE output operation, a minimum V_{IN} of 2V is required.

S2	S1	S0	STORE
0	0	0	1.8V
0	0	1	2.5V
0	1	0	3.3V
0	1	1	5.0V
1	0	0	2.1V
1	0	1	2.85V
1	1	0	3.0V
1	1	1	4.1V

Table 1. STORE Output Voltage Options

The TS3310 provides an additional Instant-On switched OUT output that completely isolates loads from the storage capacitor at the STORE output. The OUT load switch is controlled by the logic input pin OUT_ON.

The TS3310 provides an Open-Drain VGOOD output that assumes a high impedance once the STORE output is greater than 90% of the target voltage.

The TS3310 comes with an Under Voltage Lockout (UVLO) feature at 0.855V with a 20mV hysteresis. The UVLO feature monitors the input voltage and inhibits the Switching Cycle Controls from initiating switching cycles if the V_{IN} is too low. This ensures no switching currents are drawn from the input to collapse the voltage at the terminals of the battery when the internal resistance of the battery is high. Figure 1 displays the UVLO feature for the TS3310.

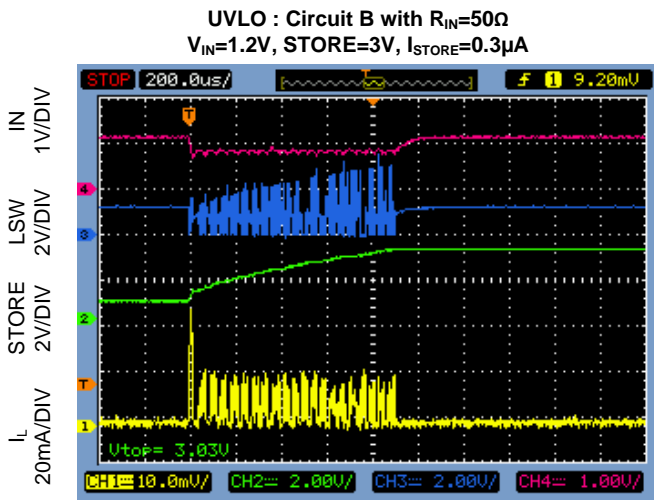

Figure 1. TS3310, UVLO=0.855V

APPLICATIONS INFORMATION

Inductor Selection

When selecting an inductor value, the value should be chosen based on output current requirements. If the input source is a small battery, make sure the choice of the inductor value considers the maximum input current that the source battery can support (based on series resistance). For example, some small button cell batteries can exhibit 5Ω series resistance, therefore a 20mA maximum input current may be appropriate (100mV drop). Consider using a large STORE capacitor to support peak loads for small batteries – see section “Bursted Load with Big Store Buffer Capacitor”.

Expected Maximum STORE Output Current

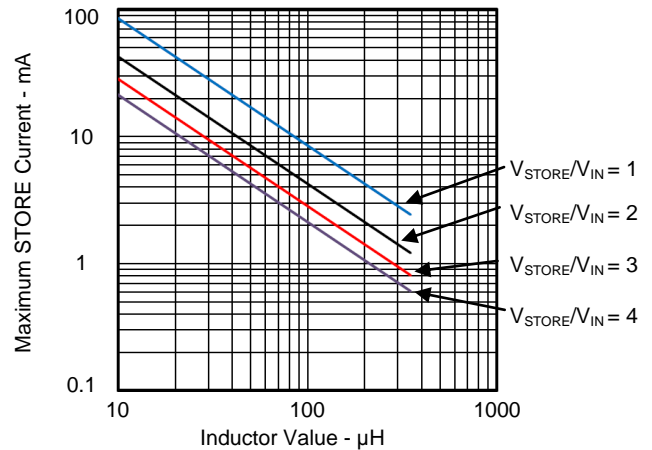

Figure 2. Expected Maximum STORE Output Current with 85% Efficiency vs Inductor Value

Maximum Input Current from Source vs Inductor Value

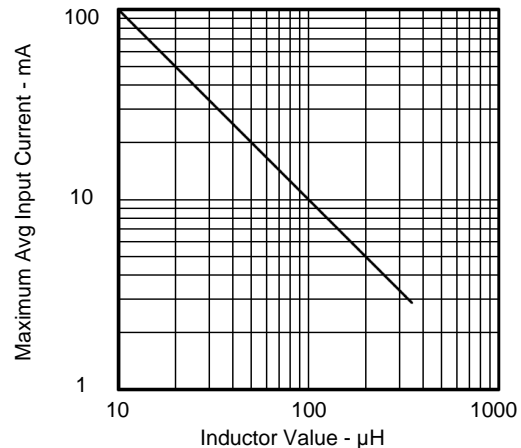

Figure 3. $I_{IN(AVG,MAX)}$ vs Inductor Value

A low ESR, shielded inductor is recommended. Depending upon the application, the inductor value will vary. For applications with load currents less than a few milliamperes, a 100μH inductor is recommended. As shown in the Efficiency Curves on Pages 4 and 5, the efficiency is greater with a larger inductor value for smaller load currents. Please refer to the two ‘Maximum Store Current vs Input Voltage’ graphs found on Page 9. Circuit A which uses a 10μH inductor is able to source larger load currents than that of Circuit B with a 100μH inductor due to the larger peak currents.

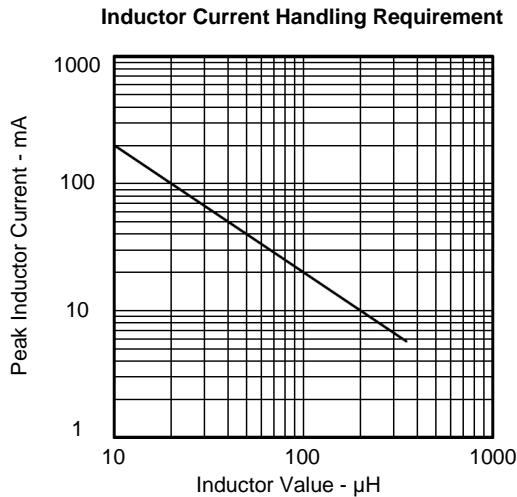

Figure 4. Inductor Peak Current vs Inductor Value

The chosen inductor's saturation current for a specific inductor value should be at least 50% greater than the peak inductor current value displayed in Figure 4, entitled 'Inductor Current Handling Requirements'. Table 2 provides a list of some inductor manufacturers.

Inductors	
Taiyo Yuden	www.t-yuden.com
Murata	www.murata.com
Coilcraft	www.coilcraft.com
Sumida	www.sumida.com

Table 2. Inductor Manufacturers

Tables 4 and 5 show some example inductors for values of 10μH and 100μH that may be used for circuit A or B. The tables include the inductors' R_{dc} (inductor series dc resistance or ESR), saturation current, and dimensions. As mentioned previously, the inductor's saturation current should always be greater than 150% of the peak inductor current; therefore the appropriate size and efficiency (dependent upon ESR) may be chosen based on the application's requirements.

To guarantee maximum output power for 10μH and 22μH operation, a C_{LSW} capacitor should be placed at the LSW pin to ground. Please refer to Table 3 for the recommended C_{LSW} values. A ceramic capacitor with a NPO or COG dielectric is recommended for C_{LSW} with a minimum voltage rating of 50V.

Inductor Value	C_{LSW}
>22μH	---
22μH	100pF
10μH	220pF

Table 3. Recommended C_{LSW} Values

Inductor Value P/N	Inductor Type	R_{dc}	Saturation Current	(LxWxH) (mm)
10μH CBC20166T100K	CBC 2016	0.82 Ω	380mA	2x1.6x1.6
10μH CBC2518T100K	CBC 2518	0.36 Ω	480mA	2.5x1.8x1.8
10μH CBC3225T100KR	CBC 3225	0.133 Ω	900mA	3.2x2.5x2.5
100μH CB2016T101K	CB 2016	4.5 Ω	70mA	2x1.6x1.6
100μH CB2518T101K	CB 2518	2.1 Ω	60mA	2.5x1.8x1.8
100μH CBC2518T101K	CBC 2518	3.7 Ω	160mA	2.5x1.8x1.8
100μH CBC3225T101KR	CBC 3225	1.4 Ω	270mA	3.2x2.5x2.5

Table 4. Taiyo-Yuden Example Inductors

Inductor Value P/N	Inductor Series	R_{dc}	Saturation Current	(LxWxH) (mm)
10μH LQH32CN100K33	LQH 32C_33	0.3 Ω	450mA	3.2x2.5x2.0
10μH LQH32CN100K53	LQH 32C_53	0.3 Ω	450mA	3.2x2.5x1.55
10μH LQH43CN100K03	LQH 43C	0.24 Ω	650mA	4.5x3.6x2.6
100μH LQH32CN101K23	LQH 32C_23	3.5 Ω	100mA	3.2x2.5x2.0
100μH LQH32CN101K53	LQH 32C_53	3.5 Ω	100mA	3.2x2.5x1.55
100μH LQH43CN101K03	LQH 43C	2.2 Ω	190mA	4.5x3.6x2.8

Table 5. Murata Example Inductors

Input and STORE Capacitor Selection

Ceramic capacitors are recommended for C_{IN} and C_{STORE} , due to ceramics' extremely low leakage currents (generally limited by very high insulation resistance). Larger value ceramics (10μF or greater) may use high constant dielectric materials, such as X5R and X7R. These materials exhibit a strong voltage coefficient and exhibit substantially lower capacitance than rated when operated near the maximum specified voltage. For these types of capacitors, use a 10V or greater voltage rating.

The STORE voltage output ripple can be reduced by increasing the value of C_{STORE} . Figure 5 displays the STORE output voltage ripple for two different storage capacitor values. The output voltage ripple reaches a floor value when the internal voltage comparator hysteresis becomes the dominant source of ripple. Below this level, larger capacitance does not help reduce the ripple.

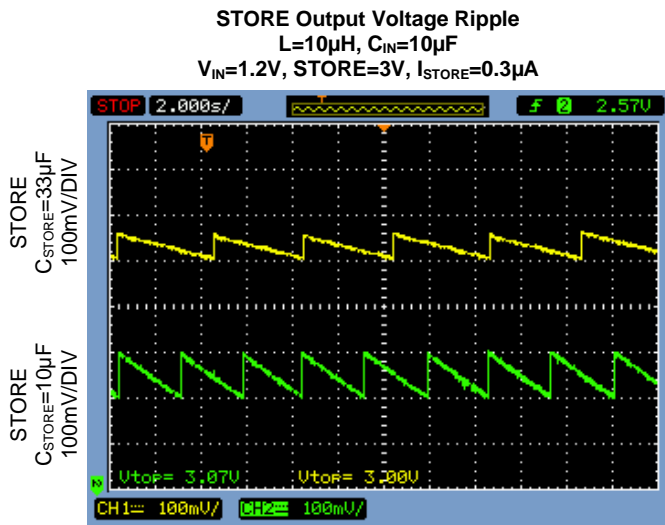

Figure 5. Output Voltage Ripple Comparison

Bursted Load with Big STORE Buffer Capacitor

The TS3310 provides a switched OUT output that is capable of sourcing short bursts of large output current by utilizing a large storage capacitor at the STORE output. Figure 6 displays an application circuit that utilizes this functionality.

The circuit is powered from a LR44 1.5V Coin Cell Battery. In this example, the load needs to be powered on once every 20 seconds for 200µsec periods. The load requires a 3.3V source and

demands 100mA current when it is powered on. Also in this example, the load continues to consume 10µA of leakage current when off. By attaching the load to OUT when the load isn't used, the TS3310 isolates the 10µA current so that overall quiescent current can be maintained. A 220µF storage capacitor is used for C_{STORE} so that it can store the necessary charge to supply the 100mA load current. The microcontroller brings the Instant-On Load Switch, OUT_ON, high when the load needs to be powered on. The TS3310 on average consumes 160nA between load bursts.

To prevent the circuit from overloading the LR44 Coin Cell Battery, a 100µH inductor is used to ensure the TS3310 only draws 10mA of current on average while recharging C_{STORE} after the load is powered off. After the load has been powered off, the TS3310 recharges the 220µF C_{STORE} capacitor within 6msec and is ready for the next burst cycle. Figure 7 displays the load being powered on for a 200µsec period and the recharge of the 220µF C_{STORE} within 6msec.

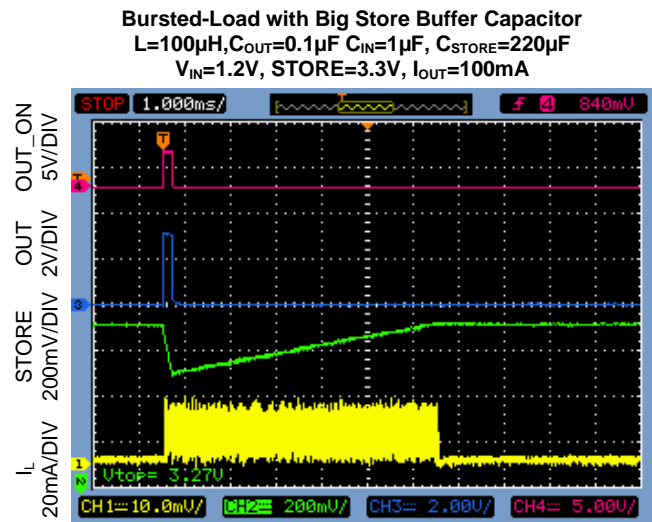

Figure 7. 220µF C_{STORE} Recovery Scope Capture

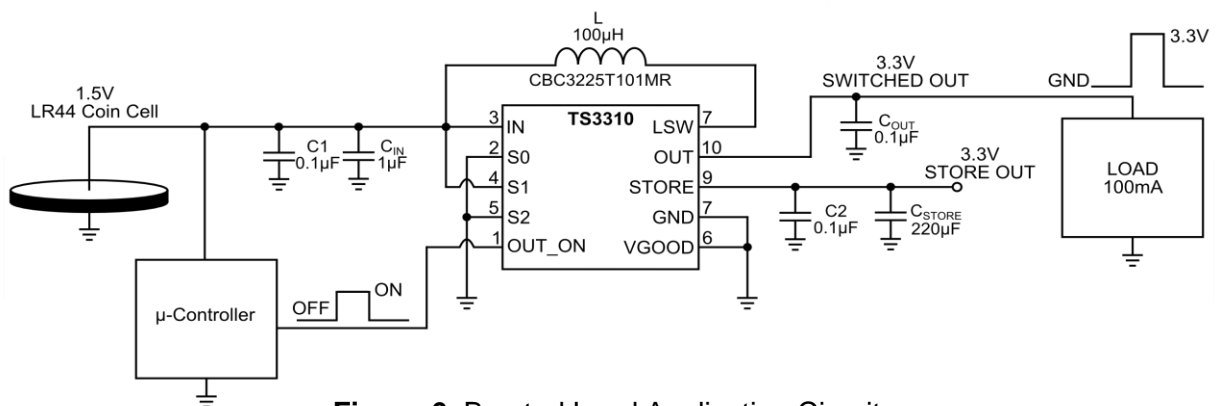
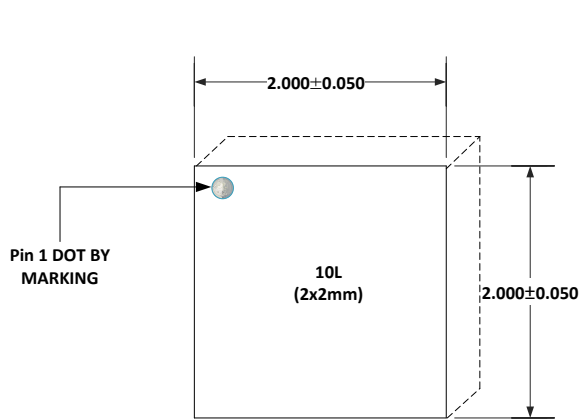
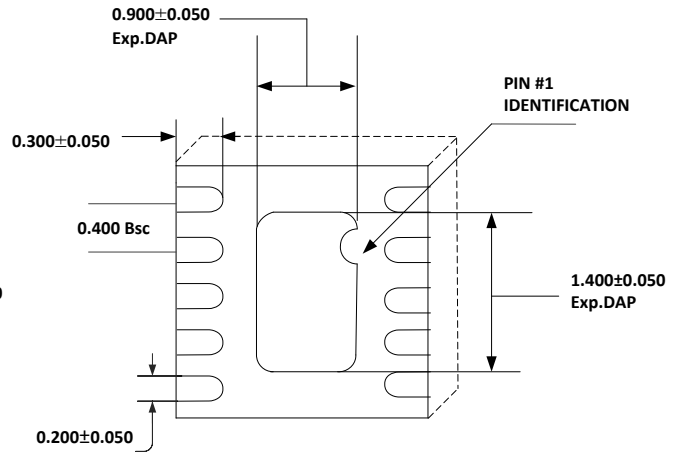

Figure 6. Bursted Load Application Circuit

PACKAGE OUTLINE DRAWING



TOP VIEW



BOTTOM VIEW

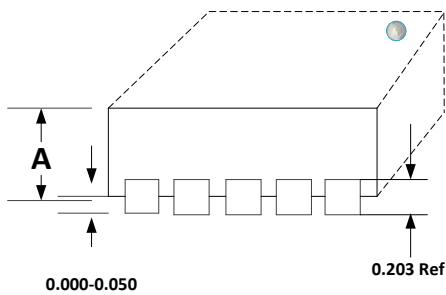

SIDE VIEW

NOTE!

- All dimensions in mm.
- This part is compliant with JEDEC MO-229 spec

A	MAX.	0.800
	NOM.	0.750
	MIN.	0.700

Information furnished by Touchstone Semiconductor is believed to be accurate and reliable. However, Touchstone Semiconductor does not assume any responsibility for its use nor for any infringements of patents or other rights of third parties that may result from its use, and all information provided by Touchstone Semiconductor and its suppliers is provided on an AS IS basis, WITHOUT WARRANTY OF ANY KIND. Touchstone Semiconductor reserves the right to change product specifications and product descriptions at any time without any advance notice. No license is granted by implication or otherwise under any patent or patent rights of Touchstone Semiconductor. Touchstone Semiconductor assumes no liability for applications assistance or customer product design. Customers are responsible for their products and applications using Touchstone Semiconductor components. To minimize the risk associated with customer products and applications, customers should provide adequate design and operating safeguards. Trademarks and registered trademarks are the property of their respective owners.

TS3310 Datasheet Revision History

Revision	Date	Description of Change	Originator
TS3310DS-r1p2-Sep13	9/13/13	Datasheet has been changed to include C_{LSW} : -Pg 1: Typical Application Circuit. -Pg 4-12: TOC Application Circuit plus updated table which includes C_{LSW} . -Pg 13: Pin Functions include C_{LSW} connection. -Pg 16: Table 3 has been added along with additional paragraph explaining Table 3. Additional Changes: -Pg 15-16: Figures 2-4 illustrate the minimum inductor value is $10\mu\text{H}$. -Pg 3: Note 4 under EC Table has been changed from ' \geq ' to '='.	DH
TS3310DS-r1p1-Jul13	7/25/13	-Pg 1: Key Features and Product Description changed to include "Active-Mode" and include I_Q vs I_{FLOOR} clarity. -Pg 8: Min Startup vs R_{IN} TOC : x-axis extended to $k\Omega$. -Pg 14: Theory of operation includes clarification between I_Q vs I_{FLOOR} .	DH
TS3310DS-r1p0-Jul 13	7/23/2013	TS3310 Final Datasheet, Revision 1.0	DH