

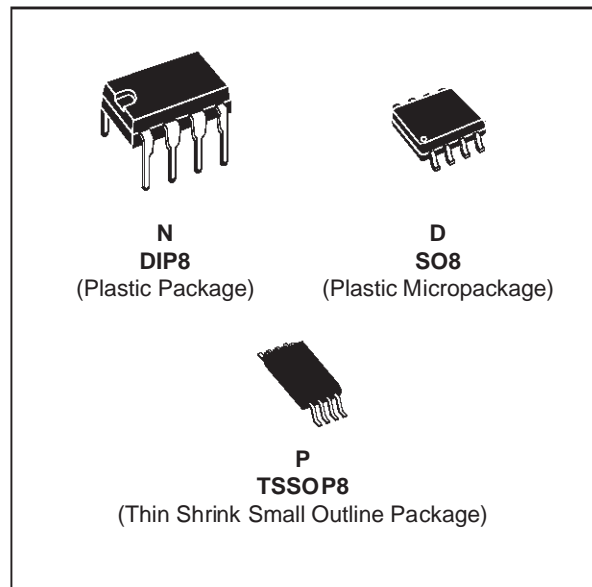

TS393C,I,M

MICROPOWER DUAL CMOS VOLTAGE COMPARATORS

- EXTREMELY LOW SUPPLY CURRENT :
9 μ A TYP/COMPARATOR
- WIDE SINGLE SUPPLY RANGE (3V to 16V)
OR DUAL SUPPLIES (± 1.5 V to ± 8 V)
- EXTREMELY LOW INPUT BIAS CURRENT :
1pA TYP
- EXTREMELY LOW INPUT OFFSET
CURRENT : 1pA TYP
- INPUT COMMON-MODE VOLTAGE RANGE
INCLUDES GND
- HIGH INPUT IMPEDANCE 10¹² Ω TYP
- FAST RESPONSE TIME : 2.5 μ s TYP FOR
5mV OVERDRIVE
- PIN-TO-PIN AND FUNCTIONALLY
COMPATIBLE WITH BIPOLAR LM393



DESCRIPTION

The TS393 is a micropower CMOS dual voltage comparator with extremely low consumption of 9 μ A typ / comparator (20 times less than bipolar LM393). Similar performances are offered by the dual micropower comparator TS3702 with a push-pull CMOS output.

Thus response times remain similar to the LM393.

ORDER CODES

Part Number	Temperature Range	Package		
		N	N	P
TS393C	0°C, +70°C	●	●	●
TS393I	-40°C, +125°C	●	●	●
TS393M	-55°C, +125°C	●	●	●

Example : TS393CN

PIN CONNECTIONS (top view)

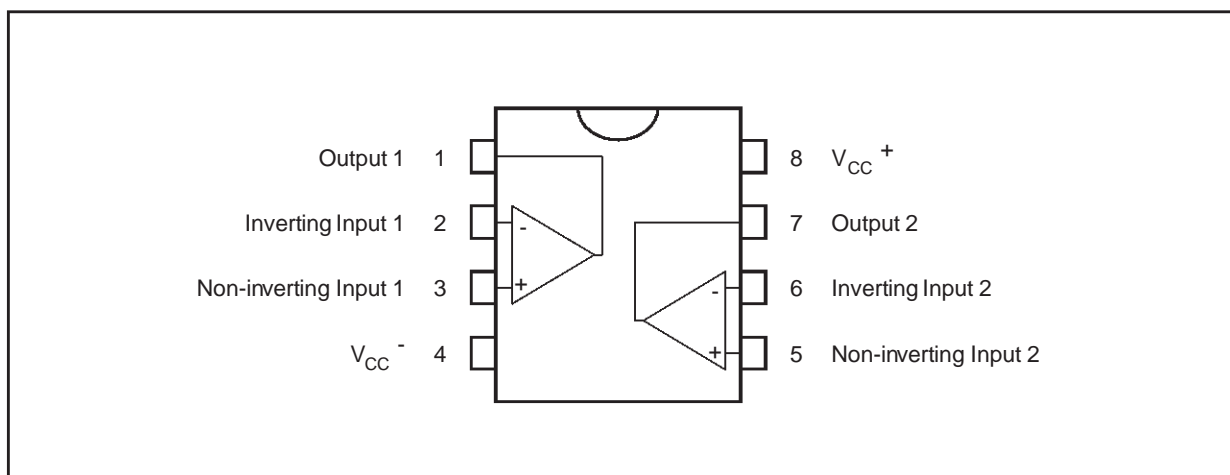

SCHEMATIC DIAGRAM (for 1/2 TS393)

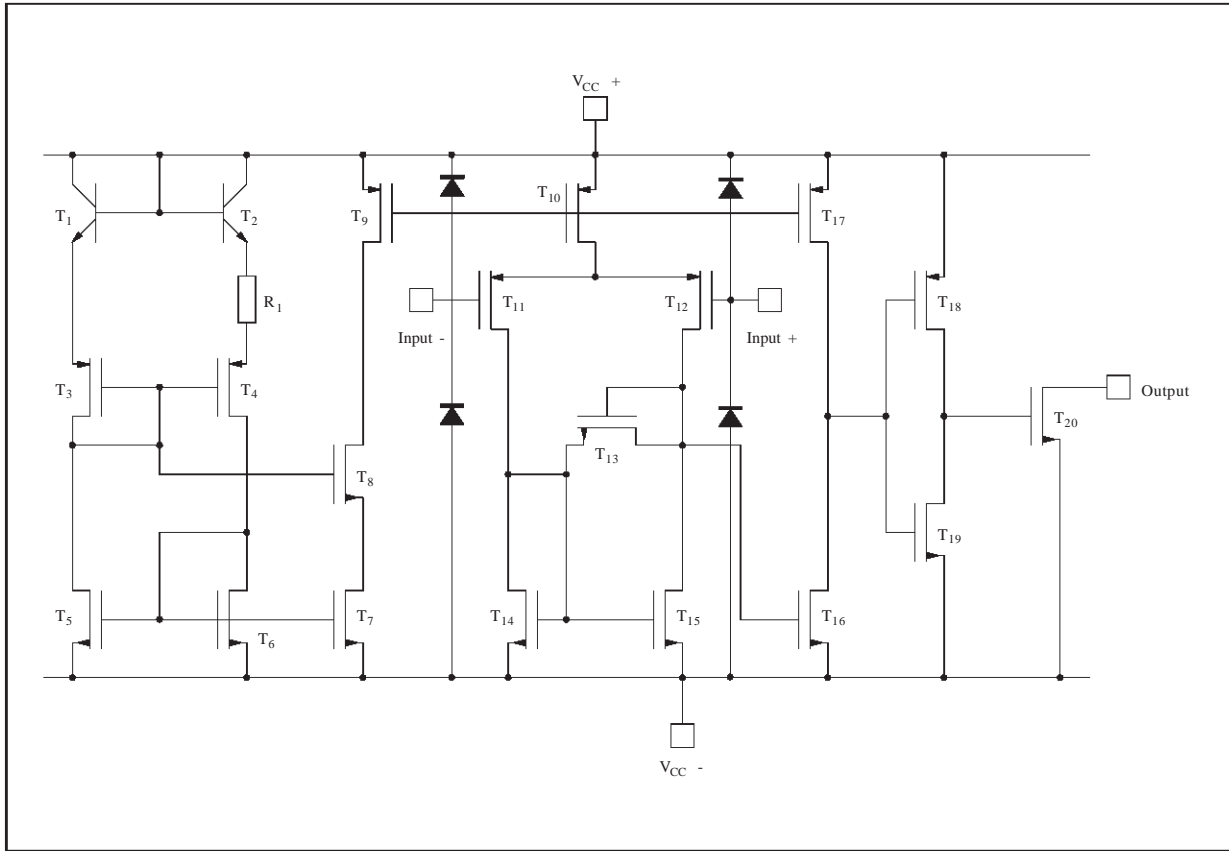

MAXIMUM RATINGS

Symbol	Parameter	Value	Unit
V_{CC}^+	Supply Voltage - (note 1)	18	V
V_{id}	Differential Input Voltage - (note 2)	± 18	V
V_i	Input Voltage - (note 3)	18	V
V_O	Output Voltage	18	V
I_O	Output Current	20	mA
I_F	Forward Current in ESD Protection Diodes on Input - (note 4)	50	mA
T_{oper}	Operating Free-Air Temperature Range	TS393C 0 to +70 TS393I -40 to +125 TS393M -55 to +125	$^{\circ}C$
T_{stg}	Storage Temperature Range	-65 to +150	$^{\circ}C$

- Notes :**
1. All voltage values, except differential voltage, are with respect to network ground terminal.
 2. Differential voltages are the non-inverting input terminal with respect to the inverting input terminal.
 3. Excursions of input voltages may exceed the power supply level. As long as the common mode voltage [$V_{icm}=(V_{in}^+ + V_{in}^-)/2$] remains within the specified range, the comparator will provide a stable output state. However, the maximum current through the ESD diodes (I_f) of the input stage must strictly be observed. The output must never exceed the power supply voltage.
 4. Guaranteed by design.
 5. Short circuit from outputs to V_{CC}^+ can cause excessive heating and eventual destruction.

OPERATING CONDITIONS

Symbol	Parameter	Value	Unit
V_{CC}^+	Supply Voltage	TS393C,I 3 to 16 TS393M 4 to 16	V
V_{icm}	Common Mode Input Voltage Range	0 to $V_{CC}^+ - 1.5$	V

ELECTRICAL CHARACTERISTICS

$V_{CC}^+ = 5V$, $V_{CC}^- = 0V$, $T_{amb} = 25^\circ C$ (unless otherwise specified)

Symbol	Parameter	Min.	Typ.	Max.	Unit
V_{io}	Input Offset Voltage $V_{IC} = V_{IC\ min.}$, $V_{CC}^+ = 5V$ to $10V$ - (note 1) $T_{min.} \leq T_{amb} \leq T_{max.}$		1.4	5 6.5	mV
I_{io}	Input Offset Current - (note 2) $V_{IC} = 2.5V$ $T_{min.} \leq T_{amb} \leq T_{max.}$		1	300	pA
I_{ib}	Input Bias Current - (note 2) $V_{IC} = 2.5V$ $T_{min.} \leq T_{amb} \leq T_{max.}$		1	600	pA
V_{icm}	Input Common Mode Voltage Range $T_{min.} \leq T_{amb} \leq T_{max.}$	0 to $V_{CC}^+ - 1.2$ 0 to $V_{CC}^+ - 1.5$			V
CMR	Common-mode Rejection Ratio $V_{IC} = V_{icm\ min.}$		71		dB
SVR	Supply Voltage Rejection Ratio $V_{CC}^+ = +5V$ to $+10V$		80		dB
I_{OH}	High Level Output Current $V_{id} = 1V$, $V_{OH} = +5V$ $T_{min.} \leq T_{amb} \leq T_{max.}$		2	40 1000	nA
V_{OL}	Low Level Output Voltage $V_{id} = -1V$, $I_{OL} = 6mA$ $T_{min.} \leq T_{amb} \leq T_{max.}$		260	400 650	mV
I_{CC}	Supply Current (2 comparators) No load - Outputs low $T_{min.} \leq T_{amb} \leq T_{max.}$		20	40 50	μA
t_{PLH}	Response Time Low to High $V_{ic} = 0V$, $f = 10kHz$, $R_L = 5.1k\Omega$, $C_L = 15pF$, Overdrive = 5mV Overdrive = 10mV Overdrive = 20mV Overdrive = 40mV TTL Input		1.5 1.2 1.0 0.8 0.7		μs
t_{PHL}	Response Time High to Low $V_{ic} = 0V$, $f = 10kHz$, $R_L = 5.1k\Omega$, $C_L = 15pF$, Overdrive = 5mV Overdrive = 10mV Overdrive = 20mV Overdrive = 40mV TTL Input		2.5 1.9 1.2 0.8 0.08		μs
t_f	Fall Time $f = 10kHz$, $C_L = 15pF$, $R_L = 5.1k\Omega$, Overdrive 50mV		25		ns

Note : 1. The specified offset voltage is the maximum value required to drive the output up to 4.5V or down to 0.3V.
2. Maximum values including unavoidable inaccuracies of the industrial test.

PACKAGE MECHANICAL DATA
8 PINS - PLASTIC DIP

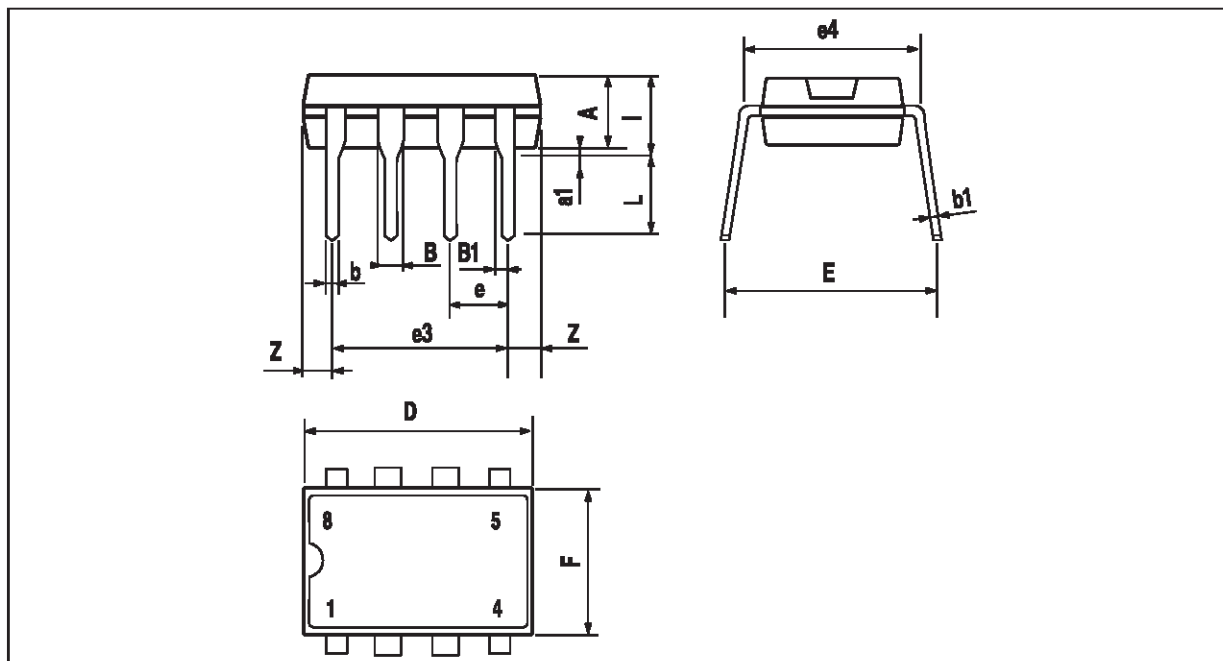

Dimensions	Millimeters			Inches		
	Min.	Typ.	Max.	Min.	Typ.	Max.
A		3.32			0.131	
a1	0.51			0.020		
B	1.15		1.65	0.045		0.065
b	0.356		0.55	0.014		0.022
b1	0.204		0.304	0.008		0.012
D			10.92			0.430
E	7.95		9.75	0.313		0.384
e		2.54			0.100	
e3		7.62			0.300	
e4		7.62			0.300	
F			6.6			0.260
i			5.08			0.200
L	3.18		3.81	0.125		0.150
Z			1.52			0.060

PACKAGE MECHANICAL DATA

8 PINS - PLASTIC MICROPACKAGE (SO)

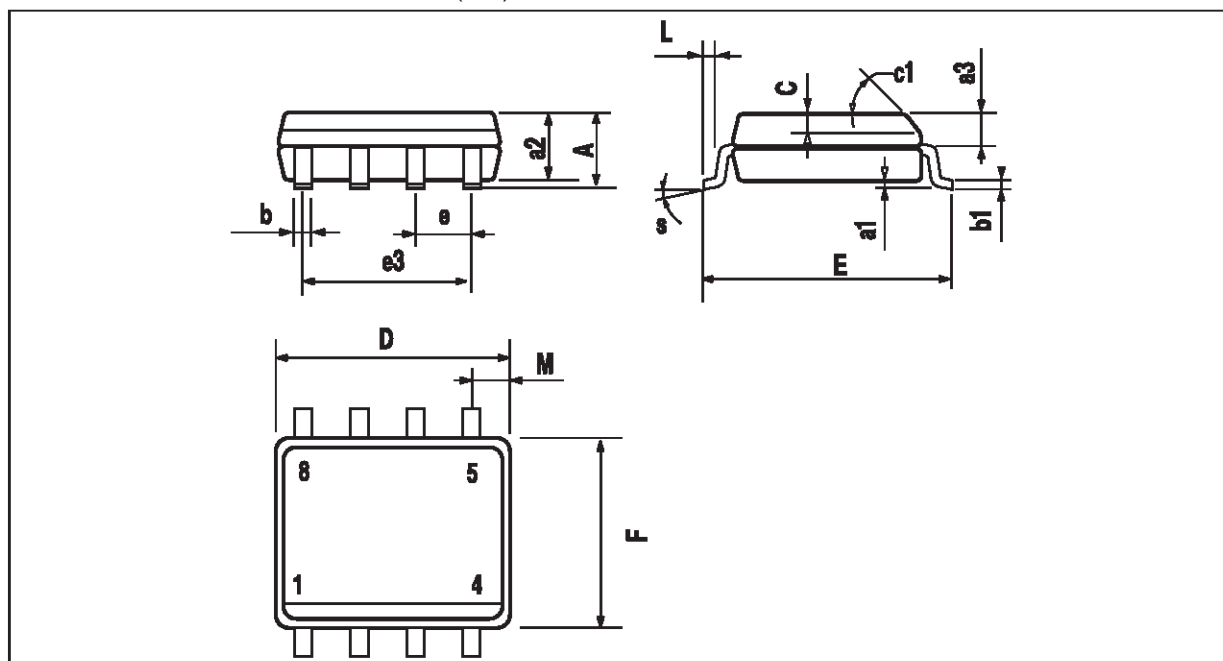

Dimensions	Millimeters			Inches		
	Min.	Typ.	Max.	Min.	Typ.	Max.
A			1.75			0.069
a1	0.1		0.25	0.004		0.010
a2			1.65			0.065
a3	0.65		0.85	0.026		0.033
b	0.35		0.48	0.014		0.019
b1	0.19		0.25	0.007		0.010
C	0.25		0.5	0.010		0.020
c1	45° (typ.)					
D	4.8		5.0	0.189		0.197
E	5.8		6.2	0.228		0.244
e		1.27			0.050	
e3		3.81			0.150	
F	3.8		4.0	0.150		0.157
L	0.4		1.27	0.016		0.050
M			0.6			0.024
S	8° (max.)					

PACKAGE MECHANICAL DATA
8 PINS - THIN SHRINK SMALL OUTLINE PACKAGE

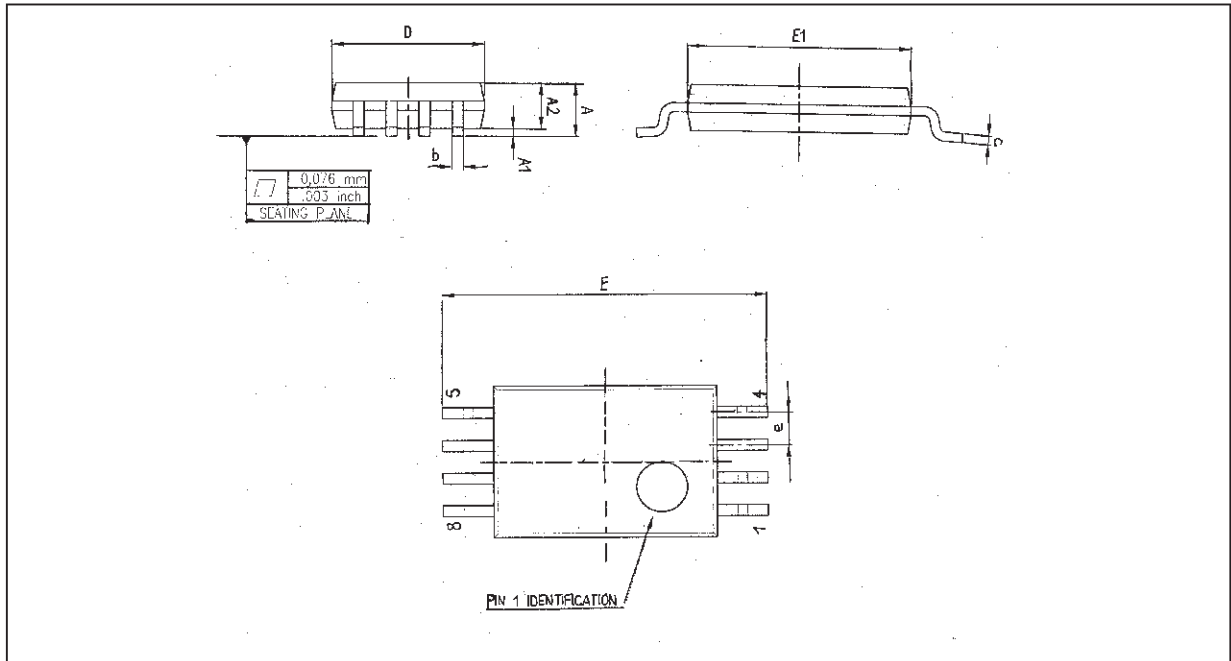

Dim.	Millimeters			Inches		
	Min.	Typ.	Max.	Min.	Typ.	Max.
A			1.20			0.05
A1	0.05		0.15	0.01		0.006
A2	0.80	1.00	1.05	0.031	0.039	0.041
b	0.19		0.30	0.007		0.15
c	0.09		0.20	0.003		0.012
D	2.90	3.00	3.10	0.114	0.118	0.122
E		6.40			0.252	
E1	4.30	4.40	4.50	0.169	0.173	0.177
e		0.65			0.025	
k	0°		8°	0°		8°
l	0.50	0.60	0.75	0.09	0.0236	0.030

Information furnished is believed to be accurate and reliable. However, STMicroelectronics assumes no responsibility for the consequences of use of such information nor for any infringement of patents or other rights of third parties which may result from its use. No license is granted by implication or otherwise under any patent or patent rights of STMicroelectronics. Specifications mentioned in this publication are subject to change without notice. This publication supersedes and replaces all information previously supplied. STMicroelectronics products are not authorized for use as critical components in life support devices or systems without express written approval of STMicroelectronics.

© The ST logo is a trademark of STMicroelectronics

© 1999 STMicroelectronics – Printed in Italy – All Rights Reserved

STMicroelectronics GROUP OF COMPANIES

Australia - Brazil - Canada - China - France - Germany - Italy - Japan - Korea - Malaysia - Malta - Mexico - Morocco
 The Netherlands - Singapore - Spain - Sweden - Switzerland - Taiwan - Thailand - United Kingdom - U.S.A.

© <http://www.st.com>