

Micropower dual CMOS voltage comparators

Datasheet – production data

Features

- Extremely low supply current: typically 9 μA per comparator
- Wide single supply range 2.7 V to 16 V or dual supplies (± 1.35 V to ± 8 V)
- Extremely low input bias current: 1 pA typical
- Extremely low input offset current: 1 pA typical
- Input common-mode voltage range includes ground
- High input impedance: 10^{12} Ω typ.
- Fast response time: 2.5 μs typ. for 5 mV overdrive
- Pin-to-pin and functionally compatible with dual bipolar LM393

Description

The TS393 device is a micropower CMOS dual voltage comparator with extremely low consumption of 9 μA typically per comparator (20 times less than the dual bipolar LM393 device). Similar performance is offered by the dual micropower comparator TS3702 with a push-pull CMOS output.

Thus response times remain similar to the LM393 device.

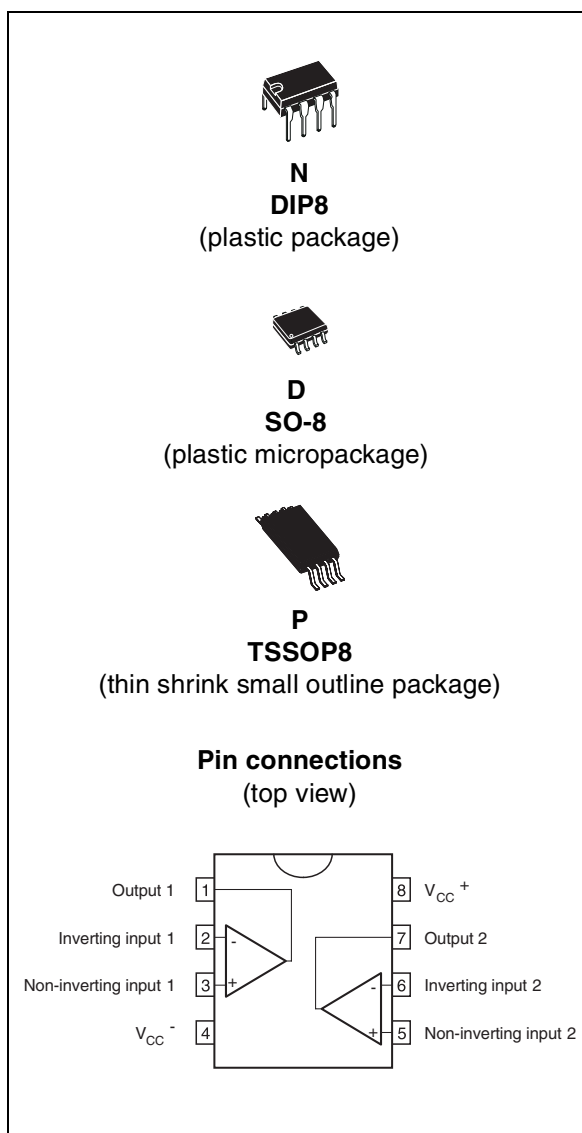

1 Absolute maximum ratings

Table 1. Absolute maximum ratings (AMR)

Symbol	Parameter	Value	Unit
V_{CC}^+	Supply voltage ⁽¹⁾	18	V
V_{id}	Differential input voltage ⁽²⁾	±18	V
V_{in}	Input voltage ⁽³⁾	18	V
V_o	Output voltage	18	V
I_o	Output current	20	mA
I_F	Forward current in ESD protection diodes on inputs ⁽⁴⁾	50	mA
T_j	Maximum junction temperature	150	°C
R_{thja}	Thermal resistance junction-to-ambient ⁽⁵⁾		
	DIP8	85	°C/W
	SO-8	125	
TSSOP8	120		
R_{thjc}	Thermal resistance junction-to-case ⁽⁵⁾		
	DIP8	41	°C/W
	SO-8	40	
TSSOP8	37		
T_{stg}	Storage temperature range	-65 to +150	°C
ESD	HBM: human body model ⁽⁶⁾	500	V
	MM: machine model ⁽⁷⁾	200	V
	CDM: charged device model ⁽⁸⁾	1	kV

1. All voltage values, except differential voltage, are with respect to network ground terminal.
2. Differential voltages are the non-inverting input terminal with respect to the inverting input terminal.
3. Excursions of input voltages may exceed the power supply level. As long as the common mode voltage $[V_{icm} = (V_{in}^+ + V_{in}^-)/2]$ remains within the specified range, the comparator will provide a stable output state. However, the maximum current through the ESD diodes (I_F) of the input stage must strictly be observed.
4. Guaranteed by design.
5. Short-circuits can cause excessive heating and destructive dissipation. Values are typical.
6. Human body model: A 100 pF capacitor is charged to the specified voltage, then discharged through a 1.5 kΩ resistor between two pins of the device. This is done for all couples of connected pin combinations while the other pins are floating.
7. Machine model: A 200 pF capacitor is charged to the specified voltage, then discharged directly between two pins of the device with no external series resistor (internal resistor < 5 Ω). This is done for all couples of connected pin combinations while the other pins are floating.
8. Charged device model: all pins and the package are charged together to the specified voltage and then discharged directly to ground through only one pin. This is done for all pins.

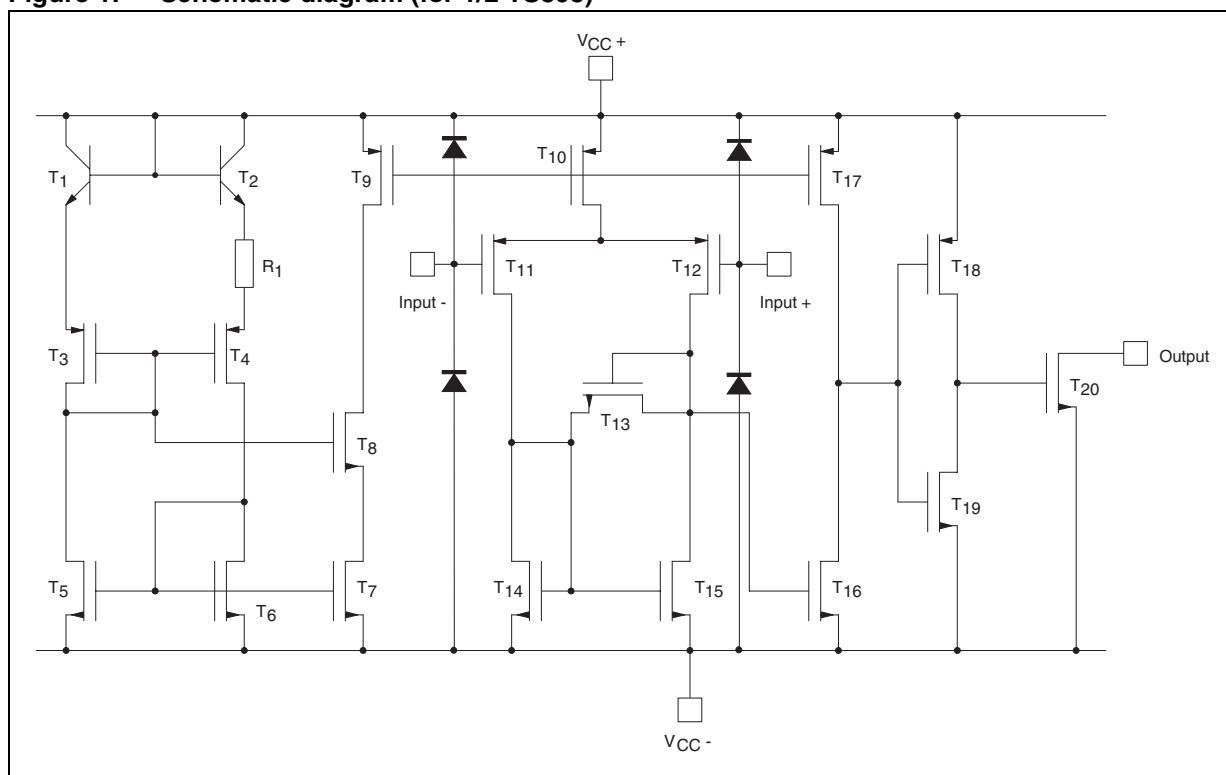

Table 2. Operating conditions

Symbol	Parameter	Value	Unit
V_{CC}^+	Supply voltage TS393C, TS393I	2.7 to 16	V
V_{icm}	Common mode input voltage range $T_{min} \leq T_{amb} \leq T_{max}$	0 to $V_{CC}^+ - 1.5$ 0 to $V_{CC}^+ - 2$	V
T_{oper}	Operating free air temperature range TS393C TS393I	0 to +70 -40 to +125	°C

2 Schematic diagram

Figure 1. Schematic diagram (for 1/2 TS393)



3 Electrical characteristics

Table 3. $V_{CC}^+ = 3\text{ V}$, $V_{CC}^- = 0\text{ V}$, $T_{amb} = 25\text{ }^\circ\text{C}$ (unless otherwise specified)

Symbol	Parameter	Min.	Typ.	Max.	Unit
V_{io}	Input offset voltage ⁽¹⁾ $V_{ic} = 1.5\text{ V}$ $T_{min} \leq T_{amb} \leq T_{max}$			5 6.5	mV
I_{io}	Input offset current ⁽²⁾ $V_{ic} = 1.5\text{ V}$ $T_{min} \leq T_{amb} \leq T_{max}$		1	300	pA
I_{ib}	Input bias current ⁽²⁾ $V_{ic} = 1.5\text{ V}$ $T_{min} \leq T_{amb} \leq T_{max}$		1	600	pA
CMR	Common-mode rejection ratio $V_{ic} = V_{icm-min}$		70		dB
SVR	Supply voltage rejection ratio $V_{CC}^+ = 3\text{ V to } 5\text{ V}$		70		dB
I_{OH}	High level output current $V_{id} = +1\text{ V}$, $V_{OH} = 3\text{ V}$ $T_{min} \leq T_{amb} \leq T_{max}$		2	40 1000	nA
V_{OL}	Low level output voltage $V_{id} = -1\text{ V}$, $I_{OL} = +6\text{ mA}$ $T_{min} \leq T_{amb} \leq T_{max}$		400	550 800	mV
I_{CC}	Supply current (each comparator) No load - outputs low $T_{min} \leq T_{amb} \leq T_{max}$		9	20 25	μA
t_{PLH}	Response time low to high $V_{ic} = 0\text{ V}$, $f = 10\text{ kHz}$, $R_L = 5.1\text{ k}\Omega$, $C_L = 50\text{ pF}$ Overdrive = 5 mV TTL input		1.5 0.7		μs
t_{PHL}	Response time high to low $V_{ic} = 0\text{ V}$, $f = 10\text{ kHz}$, $R_L = 5.1\text{ k}\Omega$, $C_L = 50\text{ pF}$ Overdrive = 5 mV TTL input		2.5 0.08		μs

1. The specified offset voltage is the maximum value required to drive the output up to 2.5 V or down to 0.3 V.

2. Maximum values include unavoidable inaccuracies of the industrial tests.

Table 4. $V_{CC}^+ = 5\text{ V}$, $V_{CC}^- = 0\text{ V}$, $T_{amb} = 25\text{ }^\circ\text{C}$ (unless otherwise specified)

Symbol	Parameter	Min.	Typ.	Max.	Unit
V_{io}	Input offset voltage ⁽¹⁾ $V_{ic} = 2.5\text{ V}$, $V_{CC}^+ = 5\text{ V to } 10\text{ V}$ $T_{min} \leq T_{amb} \leq T_{max}$		1.4	5 6.5	mV
I_{io}	Input offset current ⁽²⁾ $V_{ic} = 2.5\text{ V}$ $T_{min} \leq T_{amb} \leq T_{max}$		1	300	pA
I_{ib}	Input bias current ⁽²⁾ $V_{ic} = 2.5\text{ V}$ $T_{min} \leq T_{amb} \leq T_{max}$		1	600	pA
CMR	Common-mode rejection ratio $V_{ic} = 0\text{ V}$		71		dB
SVR	Supply voltage rejection ratio $V_{CC}^+ = +5\text{ V to } +10\text{ V}$		80		dB
I_{OH}	High level output voltage $V_{id} = 1\text{ V}$, $V_{OH} = +5\text{ V}$ $T_{min} \leq T_{amb} \leq T_{max}$		2	40 1000	nA
V_{OL}	Low level output voltage $V_{id} = -1\text{ V}$, $I_{OL} = 6\text{ mA}$ $T_{min} \leq T_{amb} \leq T_{max}$		260	400 650	mV
I_{CC}	Supply current (each comparator) No load - outputs low $T_{min} \leq T_{amb} \leq T_{max}$		10	20 25	μA
t_{PLH}	Response time low to high $V_{ic} = 0\text{ V}$, $f = 10\text{ kHz}$, $R_L = 5.1\text{ k}\Omega$, $C_L = 50\text{ pF}$, Overdrive = 5 mV Overdrive = 10 mV Overdrive = 20 mV Overdrive = 40 mV TTL input		1.5 1.2 1.0 0.8 0.7		μs
t_{PHL}	Response time high to low $V_{ic} = 0\text{ V}$, $f = 10\text{ kHz}$, $R_L = 5.1\text{ k}\Omega$, $C_L = 50\text{ pF}$, Overdrive = 5 mV Overdrive = 10 mV Overdrive = 20 mV Overdrive = 40 mV TTL input		2.5 1.9 1.2 0.8 0.08		μs
t_f	Fall time $f = 10\text{ kHz}$, $C_L = 50\text{ pF}$, $R_L = 5.1\text{ k}\Omega$ overdrive 50 mV		25		ns

1. The specified offset voltage is the maximum value required to drive the output up to 4.5 V or down to 0.3 V.
2. Maximum values including unavoidable inaccuracies of the industrial tests.

4 Package information

In order to meet environmental requirements, ST offers these devices in different grades of ECOPACK[®] packages, depending on their level of environmental compliance. ECOPACK specifications, grade definitions and product status are available at: www.st.com. ECOPACK is an ST trademark.

4.1 DIP8 package

Figure 2. DIP8 package outline

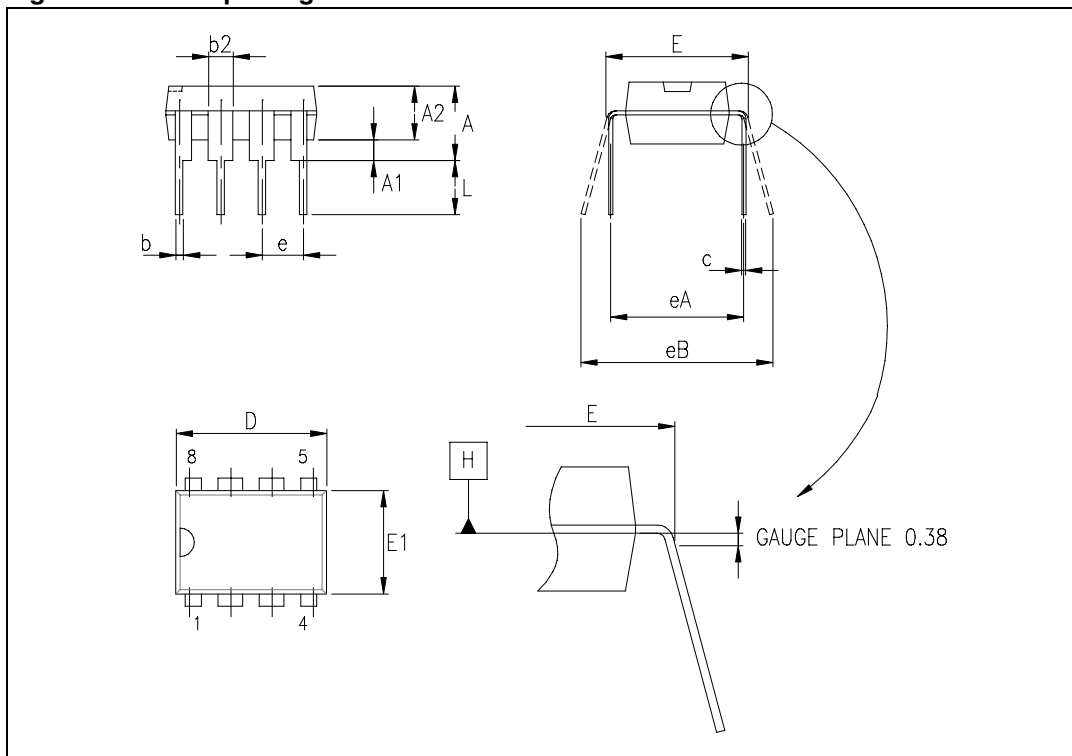

Table 5. DIP8 package mechanical data

Symbol	Dimensions					
	Millimeters			Inches		
	Min.	Typ.	Max.	Min.	Typ.	Max.
A			5.33			0.210
A1	0.38			0.015		
A2	2.92	3.30	4.95	0.115	0.130	0.195
b	0.36	0.46	0.56	0.014	0.018	0.022
b2	1.14	1.52	1.78	0.045	0.060	0.070
c	0.20	0.25	0.36	0.008	0.010	0.014
D	9.02	9.27	10.16	0.355	0.365	0.400
E	7.62	7.87	8.26	0.300	0.310	0.325
E1	6.10	6.35	7.11	0.240	0.250	0.280
e		2.54			0.100	
eA		7.62			0.300	
eB			10.92			0.430
L	2.92	3.30	3.81	0.115	0.130	0.150

4.2 SO-8 package

Figure 3. SO-8 package outline

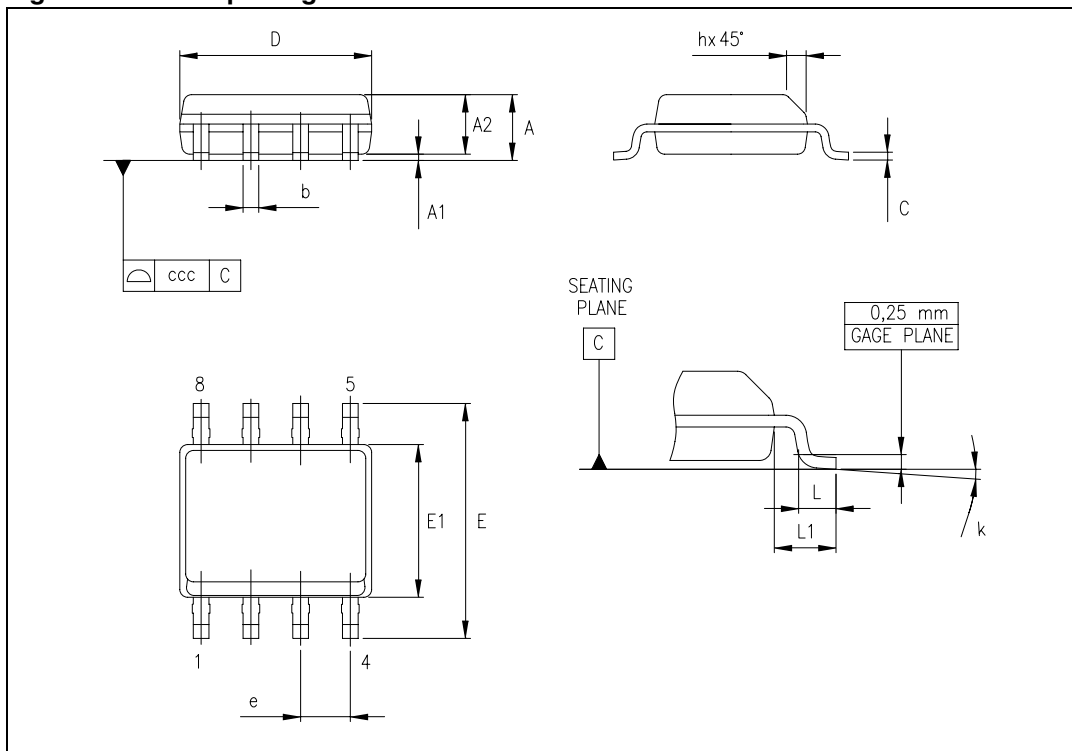

Table 6. SO-8 package mechanical data

Symbol	Dimensions					
	Millimeters			Inches		
	Min.	Typ.	Max.	Min.	Typ.	Max.
A			1.75			0.069
A1	0.10		0.25	0.004		0.010
A2	1.25			0.049		
b	0.28		0.48	0.011		0.019
c	0.17		0.23	0.007		0.010
D	4.80	4.90	5.00	0.189	0.193	0.197
E	5.80	6.00	6.20	0.228	0.236	0.244
E1	3.80	3.90	4.00	0.150	0.154	0.157
e		1.27			0.050	
h	0.25		0.50	0.010		0.020
L	0.40		1.27	0.016		0.050
k	1°		8°	1°		8°
ccc			0.10			0.004

4.3 TSSOP8 package

Figure 4. TSSOP8 package outline

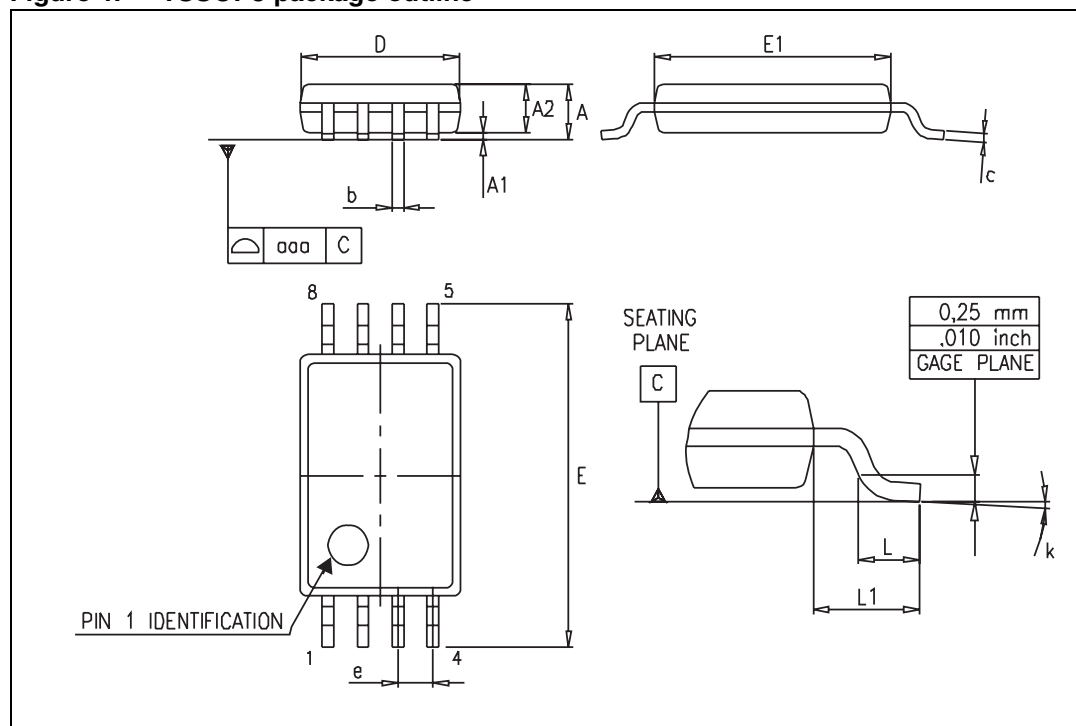

Table 7. TSSOP8 package mechanical data

Symbol	Dimensions					
	Millimeters			Inches		
	Min.	Typ.	Max.	Min.	Typ.	Max.
A			1.2			0.047
A1	0.05		0.15	0.002		0.006
A2	0.80	1.00	1.05	0.031	0.039	0.041
b	0.19		0.30	0.007		0.012
c	0.09		0.20	0.004		0.008
D	2.90	3.00	3.10	0.114	0.118	0.122
E	6.20	6.40	6.60	0.244	0.252	0.260
E1	4.30	4.40	4.50	0.169	0.173	0.177
e		0.65			0.0256	
k	0°		8°	0°		8°
L	0.45	0.60	0.75	0.018	0.024	0.030
L1		1			0.039	
aaa		0.1			0.004	

5 Ordering information

Table 8. Order codes

Order code	Temperature range	Package	Packing	Marking
TS393CN	0 °C, +70 °C	DIP8	Tube	TS393CN
TS393CD TS393CDT		SO-8	Tube or tape and reel	S393C
TS393IN	-40 °C, +125 °C	DIP8	Tube	TS393IN
TS393ID TS393IDT		SO-8	Tube or tape and reel	S393I
TS393IPT		TSSOP8	Tape and reel	S393I
TS393IYDT ⁽¹⁾		SO-8 (automotive grade)	Tube or tape and reel	S393IY

1. Qualified and characterized according to AEC Q100 and Q003 or equivalent, advanced screening according to AEC Q001 and Q 002 or equivalent.

6 Revision history

Table 9. Document revision history

Date	Revision	Changes
31-Jan-2003	1	Initial release.
31-Jul-2005	2	PPAP references inserted in the datasheet, see order codes table. ESD protection inserted in AMR table.
28-Apr-2008	3	Added footnotes for automotive grade order codes in order codes table. Updated ESD values for HBM and MM. Updated document format.
21-Nov-2012	4	Updated ECOPACK text in Section 4: Package information . Updated Table 8 (qualified TS393IYDT and removed TS393IYD order code). Minor corrections throughout document.

Please Read Carefully:

Information in this document is provided solely in connection with ST products. STMicroelectronics NV and its subsidiaries ("ST") reserve the right to make changes, corrections, modifications or improvements, to this document, and the products and services described herein at any time, without notice.

All ST products are sold pursuant to ST's terms and conditions of sale.

Purchasers are solely responsible for the choice, selection and use of the ST products and services described herein, and ST assumes no liability whatsoever relating to the choice, selection or use of the ST products and services described herein.

No license, express or implied, by estoppel or otherwise, to any intellectual property rights is granted under this document. If any part of this document refers to any third party products or services it shall not be deemed a license grant by ST for the use of such third party products or services, or any intellectual property contained therein or considered as a warranty covering the use in any manner whatsoever of such third party products or services or any intellectual property contained therein.

UNLESS OTHERWISE SET FORTH IN ST'S TERMS AND CONDITIONS OF SALE ST DISCLAIMS ANY EXPRESS OR IMPLIED WARRANTY WITH RESPECT TO THE USE AND/OR SALE OF ST PRODUCTS INCLUDING WITHOUT LIMITATION IMPLIED WARRANTIES OF MERCHANTABILITY, FITNESS FOR A PARTICULAR PURPOSE (AND THEIR EQUIVALENTS UNDER THE LAWS OF ANY JURISDICTION), OR INFRINGEMENT OF ANY PATENT, COPYRIGHT OR OTHER INTELLECTUAL PROPERTY RIGHT.

UNLESS EXPRESSLY APPROVED IN WRITING BY TWO AUTHORIZED ST REPRESENTATIVES, ST PRODUCTS ARE NOT RECOMMENDED, AUTHORIZED OR WARRANTED FOR USE IN MILITARY, AIR CRAFT, SPACE, LIFE SAVING, OR LIFE SUSTAINING APPLICATIONS, NOR IN PRODUCTS OR SYSTEMS WHERE FAILURE OR MALFUNCTION MAY RESULT IN PERSONAL INJURY, DEATH, OR SEVERE PROPERTY OR ENVIRONMENTAL DAMAGE. ST PRODUCTS WHICH ARE NOT SPECIFIED AS "AUTOMOTIVE GRADE" MAY ONLY BE USED IN AUTOMOTIVE APPLICATIONS AT USER'S OWN RISK.

Resale of ST products with provisions different from the statements and/or technical features set forth in this document shall immediately void any warranty granted by ST for the ST product or service described herein and shall not create or extend in any manner whatsoever, any liability of ST.

ST and the ST logo are trademarks or registered trademarks of ST in various countries.

Information in this document supersedes and replaces all information previously supplied.

The ST logo is a registered trademark of STMicroelectronics. All other names are the property of their respective owners.

© 2012 STMicroelectronics - All rights reserved

STMicroelectronics group of companies

Australia - Belgium - Brazil - Canada - China - Czech Republic - Finland - France - Germany - Hong Kong - India - Israel - Italy - Japan - Malaysia - Malta - Morocco - Philippines - Singapore - Spain - Sweden - Switzerland - United Kingdom - United States of America

www.st.com