

**TO-252  
(DPAK)**



**Pin Definition:**

1. Input
2. Ground
3. Output

### General Description

The TS4274 series of fixed-voltage monolithic micro-power voltage regulators is designed for a wide range of applications. This device excellent choice of use in battery-power application. Furthermore, the quiescent current increases on slightly at dropout, which prolongs battery life.

This series of fixed-voltage regulators features very low ground current (200uA Typ.) and very low drop output voltage (600mV at 400mA). This includes a tight initial tolerance of 2% typ., and very low output temperature coefficient.

### Features

- Dropout voltage typically 0.6V @Io=400mA
- Output current up to 400mA
- Output voltage trimmed before assembly
- Load dump protection
- Internal current limit
- Thermal shutdown protection

### Ordering Information

Part No.	Package	Packing
TS4274CP50 RO	TO-252	2.5Kpcs / 13" Reel

### Block Diagram

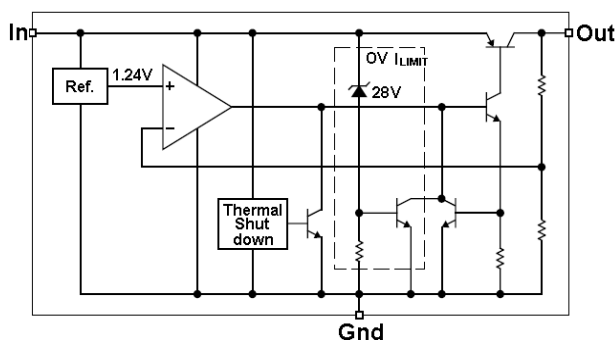

### Typical Application Circuit

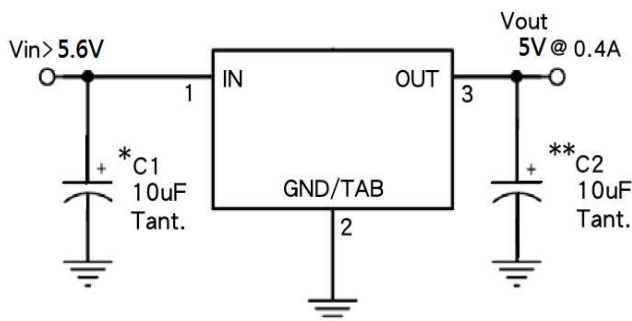

### Absolute Maximum Rating

Parameter	Symbol	Limit	Unit
Input Supply Voltage	$V_{IN}$	-18 ~ +35	V
Operation Input Supply Voltage	$V_{OPR}$	26	V
Power Dissipation	$P_D$	Internally Limited	W
Junction Temperature Range	$T_J$	+150	°C
Operating Temperature Range	$T_{OPR}$	-40 ~ + 85	°C
Storage Temperature Range	$T_{STG}$	-65 ~ +150	°C
Thermal Resistance Junction to Ambient	$R_{\theta JA}$	150	°C/W

### Electrical Characteristics ( $V_{IN}=V_{OUT}+1V$ , $I_L=5mA$ , $C_O=10\mu F$ , $T_A=25^\circ C$ , unless otherwise noted)

Parameter	Conditions	Min	Typ	Max	Unit
Output Voltage	$5mA \leq I_L \leq 500mA$ , $V_O+1V \leq V_{IN} \leq 26V$	2.40	2.5	2.60	V
		3.17	3.3	3.43	
		4.80	5.0	5.20	
Input Supply Voltage		--	--	26	V
Output Voltage Temperature Coefficient		--	50	150	ppm/ $^\circ C$
Line Regulation	$V_O+1V \leq V_{IN} \leq 26V$	--	0.05	0.5	%
Load Regulation	$5mA \leq I_L \leq 400mA$	--	0.2	2.0	%
Dropout Voltage (Note 4)	$I_L=100mA$	--	100	200	mV
	$I_L=250mA$	--	300	400	
	$I_L=400mA$	--	500	600	
Quiescent Current (Note 5)	$I_L=100\mu A$	--	200	300	$\mu A$
	$I_L=250mA$	--	10	15	mA
	$I_L=400mA$	--	25	35	mA
Short Circuit Current (Note 6)	$V_{OUT}=0$	--	600	900	mA
Output Noise, 10Hz to 100KHz, $I_L=10mA$	$C_L=2.2\mu F$	--	500	--	$\mu V_{rms}$
	$C_L=3.3\mu F$	--	350	--	
	$C_L=33\mu F$	--	120	--	
Power Supply Ripple Rejection	$F=100Hz$ , $V_r=0.5V_{ss}$	--	60	--	dB

Note 1: Absolute Maximum Rating is limits beyond which damage to the device may occur. For guaranteed specifications and test conditions see the electrical characteristics.

Note 2: Maximum positive supply voltage of 35V must be limited duration (<100mS) and duty cycle (<1%).

Note 3: The maximum allowable power dissipation is a function of the maximum junction temperature,  $T_J$ , the junction to ambient thermal resistance,  $\theta_{JA}$ , and the ambient temperature,  $T_a$ . Exceeding the maximum allowable power dissipation will cause excessive die temperature, and the regulator will go into thermal shutdown. The effective value of  $\theta_{JA}$  can be reduced by using a heatsink.

Note 3: Dropout voltage is defined as the input to output differential at which the output voltage drops 2% below its nominal value measured at 1V differential.

Note 4: Ground pin current is the regulator quiescent current. The total current drawn from the source is the sum of the ground pin current and output load current.

Note 5: Output current will decrease with increasing temperature, but it will be not dropped below 400mA at the maximum specified temperature.

### **Application Information**

The TS4274 series is a high performance with low dropout voltage regulator suitable for moderate to high current and voltage regulator application. Its 600mV(typ) dropout voltage at full load and over temperature makes it especially valuable in battery power systems and as high efficiency noise filters in post regulator applications. Unlike normal NPN transistor design, where the base to emitter voltage drop and collector to emitter saturation voltage limit the minimum dropout voltage, dropout performance of the PNP output of these devices is limited only by low  $V_{ce}$  saturation voltage.

The TS4274 series is fully protected from damage due to fault conditions. Linear current limiting is provided. Output current during overload conditions is constant. Thermal shutdown the device when the die temperature exceeds the maximum safe operating temperature. Transient protection allows device survival even when the input voltage spikes above and below nominal. The output structure of these regulators allows voltages in excess of the desired output voltage to be applied without reverse current flow.

### **Output Capacitor**

The TS4274 series requires an output capacitor to maintain stability and improve transient response. Proper capacitor selection is important to ensure proper operation. The output capacitor selection is dependent upon the ESR of the output capacitor the maintain stability. When the output capacitor is 10uF or greater, the output capacitor should have an ESR less than 2 ohm. This will improve transient response as well as promoted stability. Ultra low ESR capacitors (<100mohm), such as ceramic chip capacitors may promote instability. These very low ESR levels may cause an oscillation and/or under damped transient response. A low ESR solid tantalum capacitor works extremely well and provides good transient response and stability over temperature. Aluminum electrolytic can also be used, as long as the ESR of the capacitor is <2ohm. The value of the output capacitor can be increased without limit. Higher capacitance values help to improved transient response and ripple rejection and reduce output noise.

### **Minimum Load Current**

The TS4274 series is specified between finite loads. If the output current is too small leakage currents dominate and the output voltage rises. A 1mA minimum load current is necessary for proper regulation.

### **Input Capacitor**

An input capacitor of 1uF or greater is recommended when the device is more that 4 inches away from the bulk AC supply capacitance or when the supply is a battery. Small and surface mount ceramic chip capacitors can be used for bypassing. Larger values will help to improve ripple rejection by bypassing the input to the regulator, further improving the integrity of the output voltage.

**Application Information (Continue)**

**Thermal Characteristics**

A heatsink may be required depending on the maximum power dissipation and maximum ambient temperature of the application. Under all possible operating conditions, the junction temperature must be within the range specified under absolute maximum ratings. To determine if the heatsink is required, the power dissipated by the regulator,  $P_D$  must be calculated.

The below formula shows the voltages and currents for calculating the  $P_D$  in the regulator:

$$I_{IN} = I_L + I_G$$

$$P_D = (V_{IN} - V_{OUT}) * I_L + (V_{IN}) * I_G$$

$$\begin{aligned} \text{Ex. } P_D &= (3.3V - 2.5V) * 0.5A + 3.3V * 11mA \\ &= 400mW + 36mW \\ &= 436mW \end{aligned}$$

Remark:  $I_L$  is output load current,

$I_G$  is ground current.

$V_{IN}$  is input voltage

$V_{OUT}$  is output voltage

The next parameter which must be calculated is the maximum allowable temperature rise.

$TR(\text{max})$  is calculated by the using to formula:

$$TR(\text{max}) = T_J(\text{max}) - T_A(\text{max})$$

Where:  $T_J(\text{max})$  is the maximum allowable junction temperature, which is 125°C for commercial grade parts.

$T_A(\text{max})$  is the maximum ambient temperature which will be encountered in the application.

Using the calculated values for  $TR(\text{max})$  and  $P_D$ , the maximum allowable value for the junction to ambient thermal resistance,  $\theta_{JA}$ , can now be found:

$$\theta_{JA} = TR(\text{max}) / P_D$$

**IMPORTANT:** if the maximum allowable value for is found to be  $\geq 60^\circ\text{C}/\text{W}$  for the TO-220 package,  $\geq 80^\circ\text{C}/\text{W}$  for the TO-263 package,  $\geq 150^\circ\text{C}/\text{W}$  for the TO-252 package, or  $\geq 170^\circ\text{C}/\text{W}$  for the SOT-223 package, no heatsink is needed since the package alone will dissipate enough heat to satisfy these requirements. If the calculated value for  $\theta_{JA}$  falls below these limits, a heatsink is required.

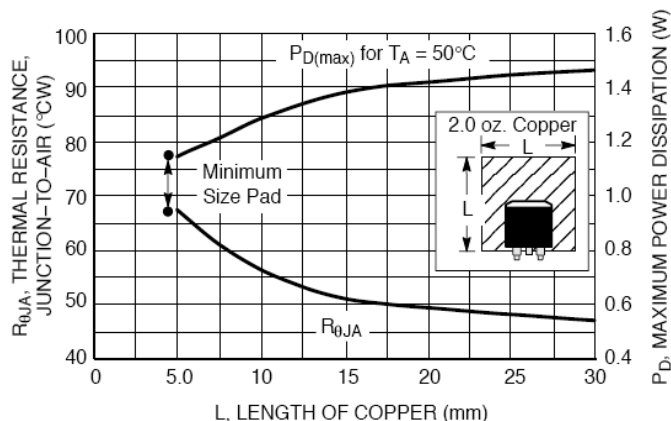

**DPAK Thermal Resistance and Maximum Power Dissipation vs. P.C.B Copper Length**

**TO-252 Mechanical Drawing**

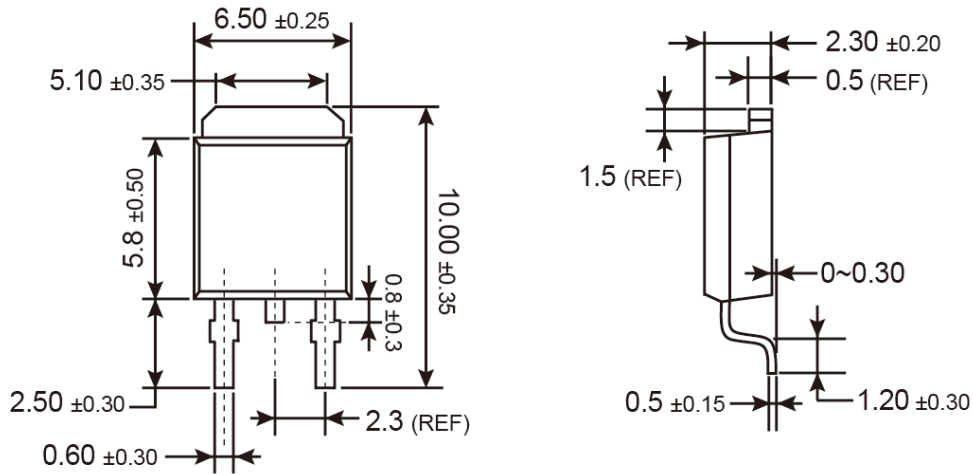

Unit: Millimeters

**Marking Diagram**

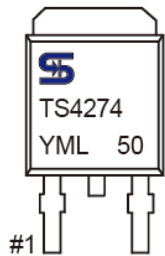

- Y** = Year Code
- M** = Month Code  
(**A**=Jan, **B**=Feb, **C**=Mar, **D**=Apr, **E**=May, **F**=Jun, **G**=Jul, **H**=Aug, **I**=Sep, **J**=Oct, **K**=Nov, **L**=Dec)
- L** = Lot Code
- 50** = Output Voltage Code

## Notice

Specifications of the products displayed herein are subject to change without notice. TSC or anyone on its behalf, assumes no responsibility or liability for any errors or inaccuracies.

Information contained herein is intended to provide a product description only. No license, express or implied, to any intellectual property rights is granted by this document. Except as provided in TSC's terms and conditions of sale for such products, TSC assumes no liability whatsoever, and disclaims any express or implied warranty, relating to sale and/or use of TSC products including liability or warranties relating to fitness for a particular purpose, merchantability, or infringement of any patent, copyright, or other intellectual property right.

The products shown herein are not designed for use in medical, life-saving, or life-sustaining applications. Customers using or selling these products for use in such applications do so at their own risk and agree to fully indemnify TSC for any damages resulting from such improper use or sale.