

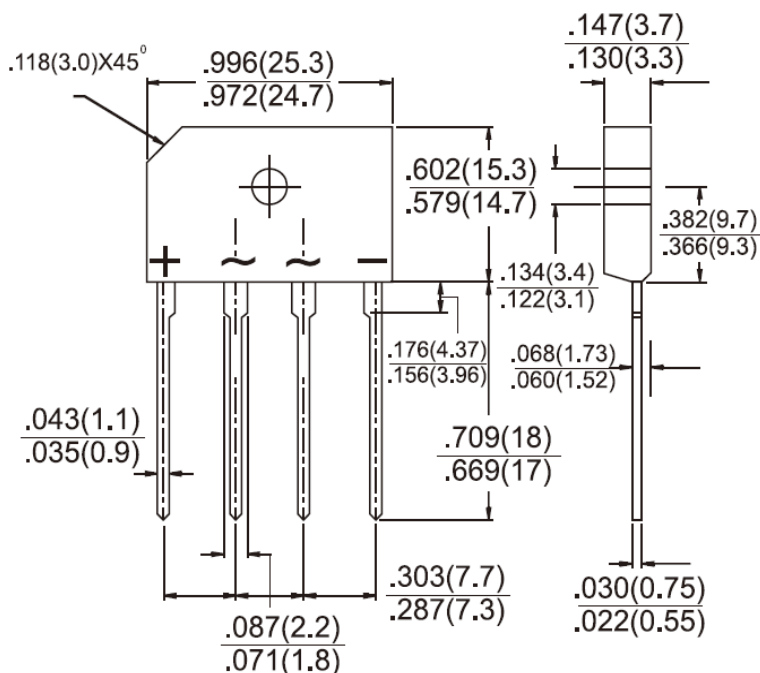

Features

- ✧ UL Recognized File # E-326243
- ✧ Glass passivated junction
- ✧ Ideal for printed circuit board
- ✧ Reliable low cost construction
- ✧ Plastic material has Underwriters laboratory Flammability Classification 94V-0
- ✧ Surge overload rating to 120 amperes peak
- ✧ High case dielectric strength of 2000V_{RMS}
- ✧ High temperature soldering guaranteed: 260°C/10 seconds at 5 lbs.,(2.3kg) tension
- ✧ Green compound with suffix "G" on packing code & prefix "G" on datecode



Mechanical Data

- ✧ Case: Molded plastic
- ✧ Weight: 4 grams
- ✧ Mounting torque : 5 in-lbs Max.

Dimensions in inches and (millimeters)

Marking Diagram

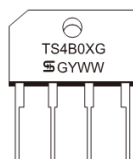

- TS4B0XG = Specific Device Code
- G = Green Compound
- Y = Year
- WW = Work Week

Maximum Ratings and Electrical Characteristics

Rating at 25 °C ambient temperature unless otherwise specified.

Single phase, half wave, 60 Hz, resistive or inductive load.

For capacitive load, derate current by 20%

Type Number	Symbol	TS4B 01G	TS4B 02G	TS4B 03G	TS4B 04G	TS4B 05G	TS4B 06G	TS4B 07G	Units
Maximum Recurrent Peak Reverse Voltage	V_{RRM}	50	100	200	400	600	800	1000	V
Maximum RMS Voltage	V_{RMS}	35	70	140	280	420	560	700	V
Maximum DC Blocking Voltage	V_{DC}	50	100	200	400	600	800	1000	V
Maximum Average Forward Rectified Current @ $T_C=115^\circ C$	$I_{F(AV)}$	4							A
Peak Forward Surge Current, 8.3 ms Single Half Sine-wave Superimposed on Rated Load (JEDEC method)	I_{FSM}	120							A
Rating of fusing ($t < 8.3ms$)	I^2t	60							A ² S
Maximum Instantaneous Forward Voltage @ 2 A (Note 1)	V_F	1.0							V
@ 4 A		1.1							
Maximum DC Reverse Current @ $T_A=25^\circ C$	I_R	5							uA
at Rated DC Blocking Voltage @ $T_A=125^\circ C$		500							
Typical Thermal Resistance (Note 2)	$R_{\theta JC}$	5.5							°C/W
Operating Temperature Range	T_J	- 55 to + 150							°C
Storage Temperature Range	T_{STG}	- 55 to + 150							°C

Note 1 : Pulse Test with PW=300 usec, 1% Duty Cycle

Note 2 : Mounted on 2" x 3" x 0.25" Al Plate Heat sink.

RATINGS AND CHARACTERISTIC CURVES (TS4B01G THRU TS4B07G)

FIG. 1- MAXIMUM FORWARD CURRENT DERATING CURVE PER BRIDGE ELEMENT

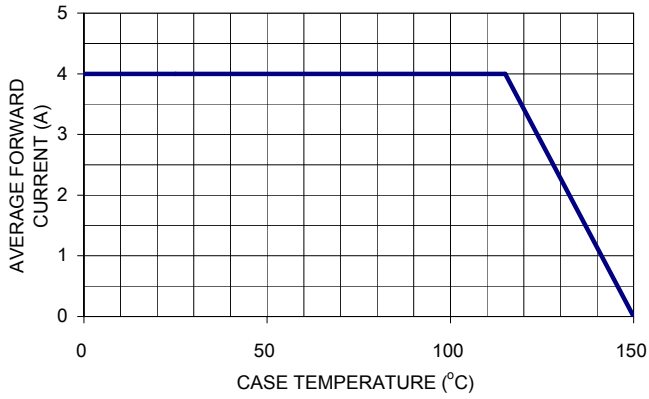

FIG. 2- TYPICAL REVERSE CHARACTERISTICS PER BRIDGE ELEMENT

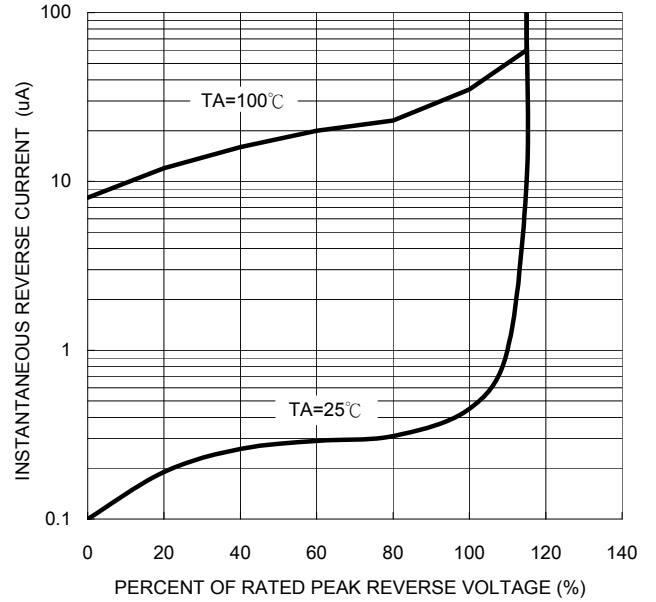

FIG. 3- MAXIMUM NON-REPETITIVE FORWARD SURGE CURRENT PER BRIDGE ELEMENT

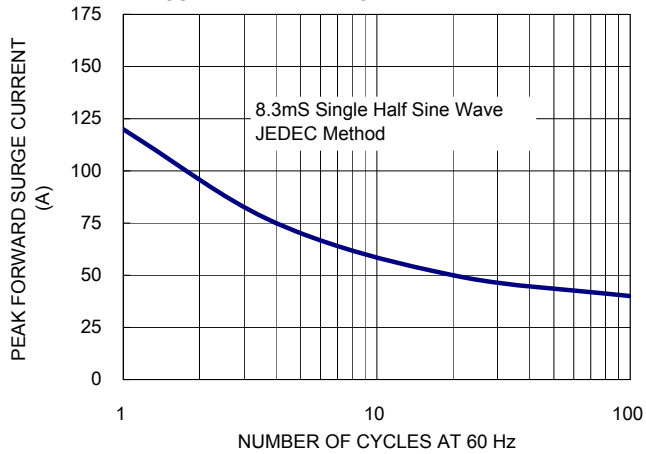

FIG. 4- TYPICAL JUNCTION CAPACITANCE

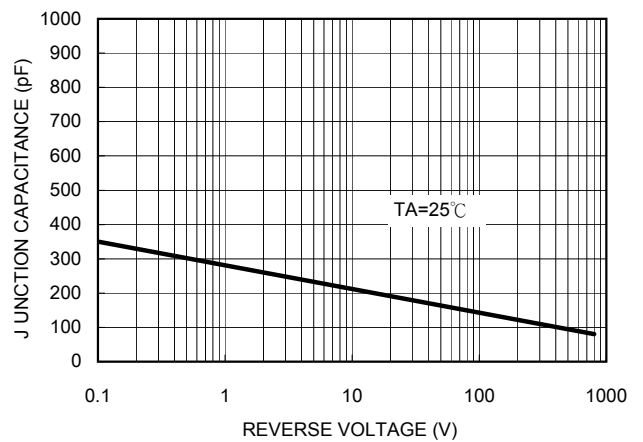
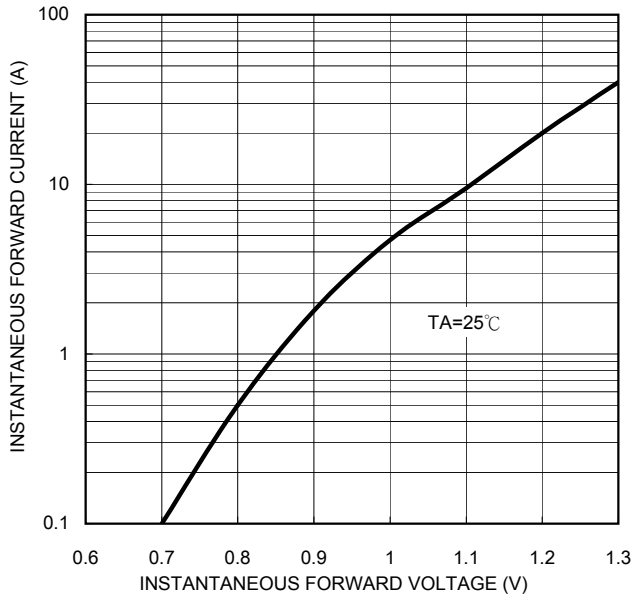

FIG. 5- TYPICAL FORWARD CHARACTERISTICS PER BRIDGE ELEMENT



Mouser Electronics

Authorized Distributor

Click to View Pricing, Inventory, Delivery & Lifecycle Information:

[Taiwan Semiconductor:](#)

[TS4B01G](#) [TS4B02G](#) [TS4B03G](#) [TS4B04G](#) [TS4B05G](#) [TS4B06G](#) [TS4B07G](#)