

5V, 5-BITS VIDEO EXCHANGE SWITCH FOR DUAL VGA SOURCE TO SINK -2V UNDERSHOOT PROTECTION WITH LOW ON-STATE RESISTANCE

Check for Samples: [TS5V522C](#)

FEATURES

- Bidirectional Data Flow, With Near-Zero Propagation Delay
- High Bandwidth, 380MHZ (typ) RGB Switching
- Low ON-State Resistance (ron) Characteristics (ron =3 Ω Typical)
- Low Input/Output Capacitance Minimizes Loading and Signal Distortion (CIO(OFF) = 8pF Typical)
- Undershoot Clamp Diodes on Data and Control Inputs.
- Low Power Consumption (Icc = 3uA Max.)
- Vcc Operation Range from 4V to 5.5V
- Data I/Os Support 0 to 5-V Signaling Levels (0.8V, 1.2V, 1.5V, 1.8V, 2.5V, 3.3V, 4V)
- Allow to pull up resistor up to 5V on the I/O
- I_{off} Supports Live Insertion, Partial Power Down Mode, and Back Drive Protection
- Latch-Up Performance Exceeds 100Ma Per JESD 78, Class II.
- ESD Performance Tested Per JESD 22
 - 2000-V Human-Body Model (A114-B, Class II)
 - 200-V Machine Model (A115-A)
 - 1000-V Charged-Device Model (C101)

APPLICATIONS

- Digital and Analog Signal Interface
- Audio and Video Signal Interface
- High Speed Signal Bus Exchange
- Bus Isolation, Interleaving
- Notebook Computer Graphics Control

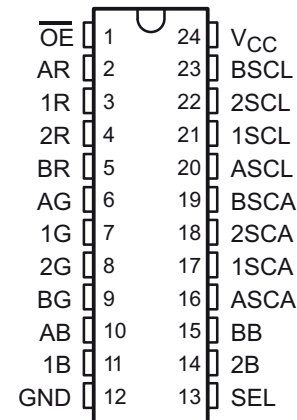

DESCRIPTION

The TS5V522C is high bandwidth analog switches offering a 2:2 dual-graphics crossover solution for VGA signal switching. The device is designed for switching between 2 VGA sources to either of the two destinations within a laptop computer. The TS5V522C integrates 5 very high-frequency 380Mhz (typ) SPDT switches for RGB signals, 2 pairs of level-translating buffer for the HSYNC and VSYNC lines, and integrated ESD protection. The 5 crossover switches can be controlled by either 5V or 3.3V TTL control signals.

The TS5V522C would bypass the VGA analog signal to destination with less distortions. DDC Channel (SCA, SCL) may require to +5Vopen drain level at the VGA connector and it may require a pull up resistor on the destination side. Active undershoot-protection circuitry on the data ports of the TS5V522C provide protection for undershoots up to -2V by sensing an undershoot event and ensuring that the switch remains in the proper off state.

To ensure the high-impedance state during power up or power down, \overline{OE} should be tied to V_{CC} through a pull up resistor; the minimum value of the resistor is determined by the current-sinking capability of the driver.



Please be aware that an important notice concerning availability, standard warranty, and use in critical applications of Texas Instruments semiconductor products and disclaimers thereto appears at the end of this data sheet.



These devices have limited built-in ESD protection. The leads should be shorted together or the device placed in conductive foam during storage or handling to prevent electrostatic damage to the MOS gates.

ORDERING INFORMATION⁽¹⁾

T_A	PACKAGE ⁽²⁾		ORDERABLE PART NUMBER	TOP-SIDE MARKING
–40°C to 85°C	SSOP (QSOP) – DBQ	Tape and Reel	TS5V522CDBQR	TS5V522C
	TSSOP – PW	Tape and Reel	TS5V522CPWR	TE522C

(1) For the most current package and ordering information, see the Package Option Addendum at the end of this document, or see the TI Web site at www.ti.com.

(2) Package drawings, thermal data, and symbolization are available at www.ti.com/packaging.

Table 1. FUNCTION TABLE

CONTROL		INPUT/OUTPUTS		FUNCTIONS	
\overline{OE}	SEL	1 X	2 X		
L	L	A X	B X	1X port = AX port 2x port = BX port	
L	H	B X	A X	1X port = BX port 2x port = AX port	
H	X	Z	Z	Disconnect	

Table 2. PIN DESCRIPTION

PIN NAME	DESCRIPTION
xR, xG, xB	Analog Video I/Os
xSCL, xSCA	Analog sync I/Os
\overline{OE}	Enable pin
\overline{EN}	Input select

PARAMETER DEFINITIONS

PARAMETER	DESCRIPTION
r_{ON}	Resistance between the input and output ports with the switch in the ON-state
I_{OZ}	Output leakage current measured at the D and S ports with the switch in the OFF-state
I_{OS}	Short circuit current measured at the I/O pins.
V_{IN}	Voltage at the IN pin
V_{EN}	Voltage at the \overline{EN} pin
C_{IN}	Capacitance at the control inputs (\overline{EN} , IN)
C_{OFF}	Capacitance at the analog I/O port when the switch is OFF
C_{ON}	Capacitance at the analog I/O port when the switch is ON
V_{IH}	Minimum input voltage for logic high for the control inputs (\overline{EN} , IN)
V_{IL}	Minimum input voltage for logic low for the control inputs (\overline{EN} , IN)
V_H	Hysteresis voltage at the control inputs (\overline{EN} , IN)
V_{IK}	I/O and control inputs diode clamp voltage (\overline{EN} , IN)
V_I	Voltage applied to the I/O pins when I/O is the switch input.
V_O	Voltage applied to the I/O pins when I/O is the switch output.
I_{IH}	Input high leakage current of the control inputs (\overline{EN} , IN)
I_{IL}	Input low leakage current of the control inputs (\overline{EN} , IN)
I_I	Current into the I/O pins when I/O is the switch input.
I_O	Current into the I/O pins when I/O is the switch output.
I_{off}	Output leakage current measured at the I/O ports with $V_{CC} = 0$
t_{ON}	Propagation delay measured between 50% of the digital input to 90% of the analog output when switch is turned ON.
t_{OFF}	Propagation delay measured between 50% of the digital input to 90% of the analog output when switch is turned OFF.
BW	Frequency response of the switch in the ON-state measured at –3 dB
X_{TALK}	Unwanted signal coupled from channel to channel. Measured in –dB. $X_{TALK} = 20 \text{ LOG } V_{OUT}/V_{IN}$. This is a non-adjacent crosstalk.
O_{IRR}	Off-isolation is the resistance (measured in –dB) between the input and output with the switch OFF.
D_G	Magnitude variation between analog input and output pins when the switch is ON and the DC offset of composite video signal varies at the analog input pin. In NTSC standard the frequency of the video signal is 3.58 MHz and DC offset is from 0 to 0.714 V.
D_P	Phase variation between analog input and output pins when the switch is ON and the DC offset of composite video signal varies at the analog input pin. In NTSC standard the frequency of the video signal is 3.58 MHz and DC offset is from 0 to 0.714 V.
I_{CC}	Static power supply current
I_{CCD}	Variation of I_{CC} for a change in frequency in the control inputs (\overline{EN} , IN)
ΔI_{CC}	This is the increase in supply current for each control input that is at the specified voltage level, rather than V_{CC} or GND.

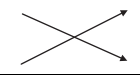
LOGIC DIAGRAM (XX GATE)

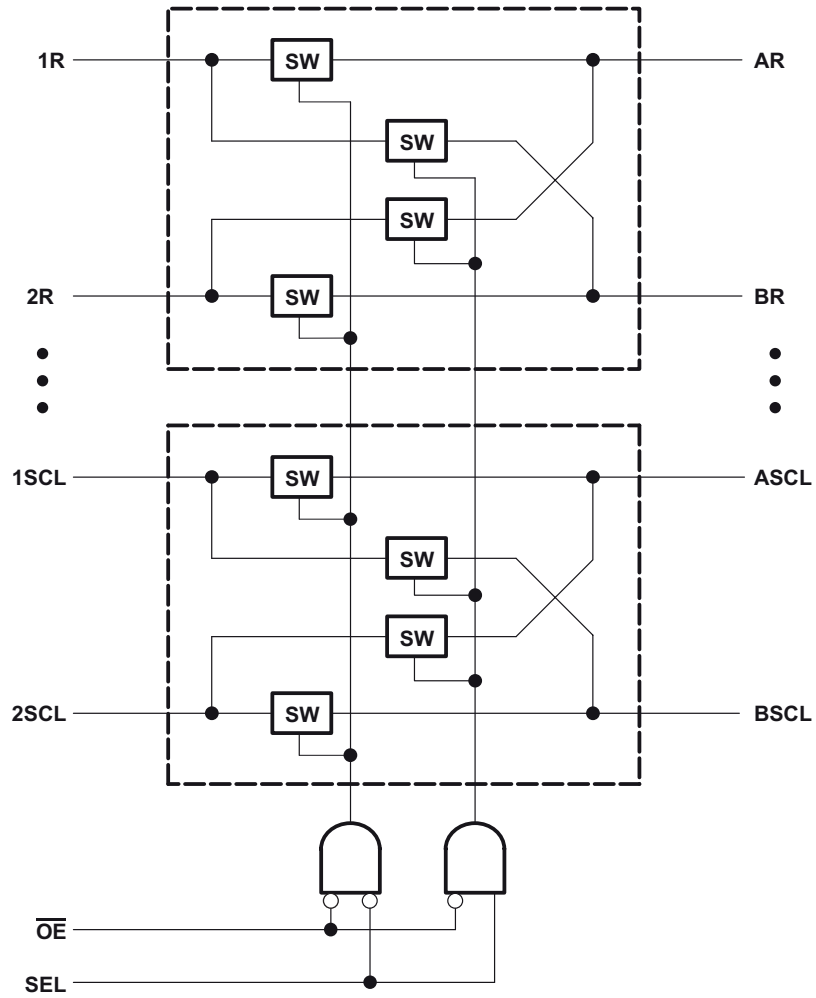

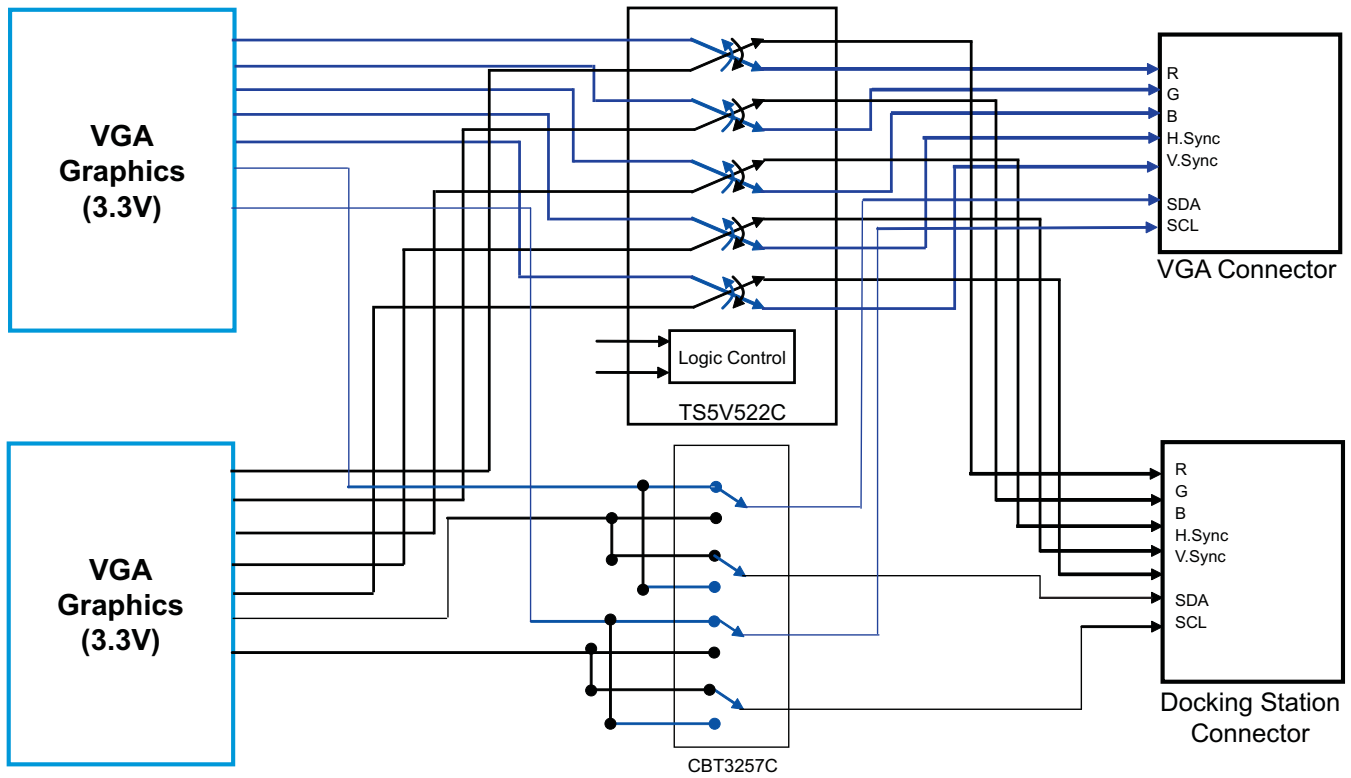
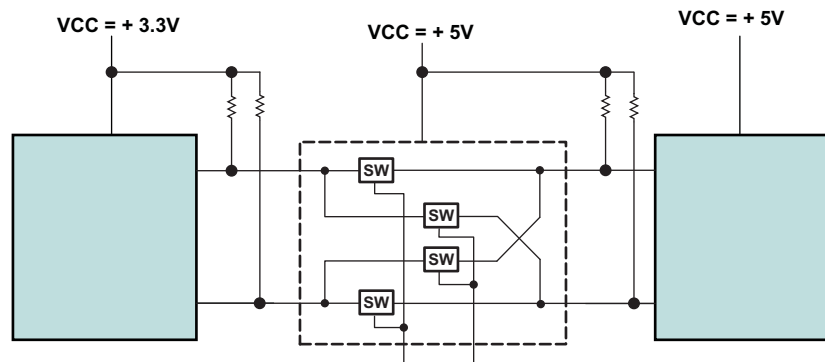

Figure 1. Typical Design Examples for Dual VGA Source Signal Exchange



Design Notes:

1. DDC (SCL,SDA) is open drain I²C Bus type and need pull up resistors. N-Channel FET Switch allow to pull up desired Vcc Level not exceeding the Vcc of FET Switch
2. VGA (H.Sync, V.Sync) are TTL/CMOS Type from the source of V ideo and it may required pull up to achieve as high as 5V Signal level to meet VGA Specifications too.

Figure 2. Typical Design Example for Level Shifting with N-Channel FET Switch

TS5V522C

SCD317 – MARCH 2011

www.ti.com

ABSOLUTE MAXIMUM RATINGS⁽¹⁾

over operating free-air temperature range (unless otherwise noted)

		MIN	MAX	UNIT
V _{CC}	Supply voltage range	-0.5	7	V
V _{IN}	Control input voltage range ⁽²⁾⁽³⁾	-0.5	7	V
V _{I/O}	Output voltage range ⁽²⁾⁽³⁾⁽⁴⁾	-0.5	7	V
I _{IK}	Control input clamp current	V _{IN} < 0	-50	mA
I _{I/OK}	I/O port clamp current	V _{I/O} < 0	-50	mA
I _{I/O}	ON-state switch current ⁽⁵⁾		±128	mA
	Continuous current through V _{CC} or GND		±100	mA
T _{stg}	Storage temperature range	-65	150	°C

- (1) Stresses beyond those listed under "Absolute Maximum Ratings" may cause permanent damage to the device. These are stress ratings only, and functional operation of the device at these or any other conditions beyond those indicated under "Recommended Operating Conditions" is not implied. Exposure to absolute-maximum-rated conditions for extended periods may affect device reliability.
- (2) All input and output negative voltages are with respect to ground unless otherwise specified.
- (3) The input and output voltage ratings may be exceeded if the input and output clamp-current ratings are observed.
- (4) V_I and V_O are used to denote specific conditions for V_{I/O}.
- (5) I_I and I_O are used to denote specific conditions of I_{I/O}.

THERMAL IMPEDANCE RATINGS

over operating free-air temperature range (unless otherwise noted)

			UNIT
θ _{JA}	Package thermal impedance	DBQ package ⁽¹⁾	90
		PW package ⁽¹⁾	108
			°C/W

- (1) The package thermal impedance is calculated in accordance with JESD 51-7.

RECOMMENDED OPERATING CONDITIONS⁽¹⁾

over operating free-air temperature range (unless otherwise noted)

		MIN	MAX	UNIT
V _{CC}	Supply voltage	4	5.5	V
V _{IH}	High-level control input voltage (\overline{EN} , IN)	2	5.5	V
V _{IL}	Low-level control input voltage (\overline{EN} , IN)	0	0.8	V
V _{ANALOG}	Analog input/output voltage	0	V _{CC}	V
T _A	Operating free-air temperature	-40	85	V

- (1) All unused control inputs of the device must be held at V_{CC} or GND to ensure proper device operation. Refer to the TI application report, *Implication of slow or Floating CMOS Inputs*, literature number [SCBA004](#).

ELECTRICAL CHARACTERISTICS⁽¹⁾

over recommended operating free-air temperature range (unless otherwise noted)

PARAMETER		TEST CONDITIONS		MIN	TYP ⁽²⁾	MAX	UNIT	
V_{IK}	\overline{EN} , IN	$V_{CC} = 4.5\text{ V}$,	$I_{IN} = -18\text{ mA}$			-1.8	V	
V_H	\overline{EN} , IN					400	mV	
I_{IH}	\overline{EN} , IN	$V_{CC} = 5.5\text{ V}$,	V_{IN} and $V_{EN} = V_{CC}$			± 1	μA	
I_{IL}	\overline{EN} , IN	$V_{CC} = 5.5\text{ V}$,	V_{IN} and $V_{EN} = \text{GND}$			± 1	μA	
I_{OZ} ⁽³⁾		$V_{CC} = 5.5\text{ V}$,	$V_O = 0$ to 5.5 V , $V_I = 0$,			± 10	μA	
I_{OS}		$V_{CC} = 5.5\text{ V}$,	$V_O = 0$ to 5.5 V , $V_I = 0$,			± 110	mA	
I_{off}		$V_{CC} = 0\text{ V}$,	$V_O = 0$ to 5.5 V , $V_I = 0$			± 1	μA	
I_{CC}		$V_{CC} = 5.5\text{ V}$,	$I_{IO} = 0$,			3	μA	
ΔI_{CC}	\overline{EN} , IN	$V_{CC} = 5.5\text{ V}$,	One input at 3.4 V ,			2.5	mA	
I_{CCD}		$V_{CC} = 5.5\text{ V}$, $V_{EN} = \text{GND}$,	I/O ports are open, V_{IN} switching 50% duty cycle			0.25	mA/MHz	
C_{in}	\overline{EN} , IN	V_{IN} or $V_{EN} = 0\text{ V}$,	$f = 1\text{ MHz}$			3.5	pF	
C_{OFF}	D port	$V_{IO} = 3\text{ V}$ or 0 V ,	Switch OFF,	$V_{IN} = V_{CC}$ or GND		8.5	pF	
	S port		Switch ON,			5.5		
C_{ON}		$V_I = 0\text{ V}$,	$f = 1\text{ MHz}$, output open,	Switch ON		16.5	pF	
r_{ON} ⁽⁴⁾		$V_{CC} = 4.5\text{ V}$,	$V_I = 1\text{ V}$,	$I_O = 13\text{ mA}$, $R_L = 75\Omega$		3	7	Ω
			$V_I = 2\text{ V}$,	$I_O = 26\text{ mA}$, $R_L = 75\Omega$		3	10	

(1) V_I , V_O , I_I , and I_O refer to the I/O pins.

(2) All typical values are at $V_{CC} = 5\text{ V}$ (unless otherwise noted). $T_A = 25^\circ\text{C}$

(3) For I/O ports, the parameter I_{OZ} includes the input leakage current.

(4) Measured by the voltage drop between the D and S terminals at the indicated current through the switch. ON-state resistance is determined by the lower of the voltages of the two (S or D) terminals.

SWITCHING CHARACTERISTICS

over operating free-air temperature range (unless otherwise noted), see [Figure 9](#)

PARAMETER	FROM (INPUT)	TO (OUTPUT)	MIN	TYP	MAX	UNIT
t_{ON}	S	D	1		6.6	ns
t_{OFF}	S	D	1		6.0	ns

DYNAMIC CHARACTERISTICS

over recommended operating free-air temperature range, $V_{CC} = 5\text{ V} \pm 10\%$ (unless otherwise noted)

PARAMETER	TEST CONDITIONS	MIN	TYP ⁽¹⁾	MAX	UNIT
D_G	$R_L = 150\Omega$, $f = 3.58\text{ MHz}$, see Figure 10		0.37		%
D_P	$R_L = 150\Omega$, $f = 3.58\text{ MHz}$, see Figure 10		0.0330		Deg
B_W	$R_L = 150\Omega$, see Figure 11		380		MHz
X_{TALK}	$R_{IN} = 10\Omega$, $R_L = 150\Omega$, $f = 10\text{ MHz}$, see Figure 11		-83		dB
O_{IRR}	$R_L = 150\Omega$, $f = 10\text{ MHz}$, see Figure 11		-44		dB

(1) All typical values are at $V_{CC} = 5\text{ V}$ (unless otherwise noted). $T_A = 25^\circ\text{C}$.

TS5V522C

SCDS317 –MARCH 2011

www.ti.com

over recommended operating free-air temperature range, $V_{CC} = 5\text{ V} \pm 10\%$ (unless otherwise noted)

PARAMETER	TEST CONDITIONS	MIN	TYP ⁽¹⁾	MAX	UNIT
D_G	$R_L = 75\ \Omega$, $f = 3.58\text{ MHz}$, see Figure 10		0.37		%
D_P	$R_L = 75\ \Omega$, $f = 3.58\text{ MHz}$, see Figure 10		0.0330		Deg
B_W	$R_L = 75\ \Omega$, see Figure 11		330		MHz
X_{TALK}	$R_{IN} = 10\ \Omega$, $R_L = 150\ \Omega$, $f = 10\text{ MHz}$, see Figure 11		-83		dB
O_{IRR}	$R_L = 75\ \Omega$, $f = 10\text{ MHz}$, see Figure 11		-44		dB

(1) All typical values are at $V_{CC} = 5\text{ V}$ (unless otherwise noted). $T_A = 25^\circ\text{C}$.

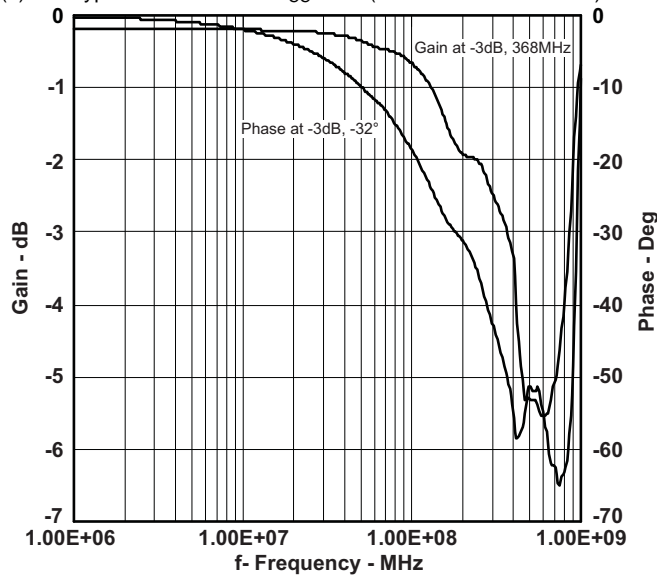

Figure 3. Frequency Response

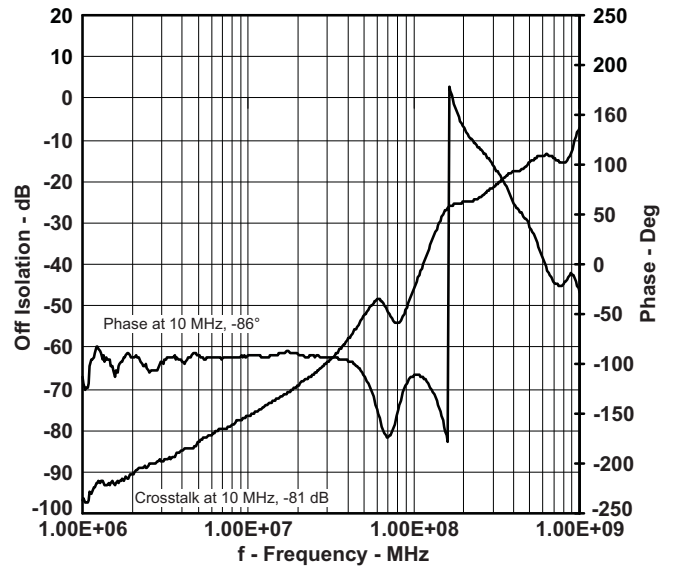

Figure 4. Non-adjacent Crosstalk vs Frequency

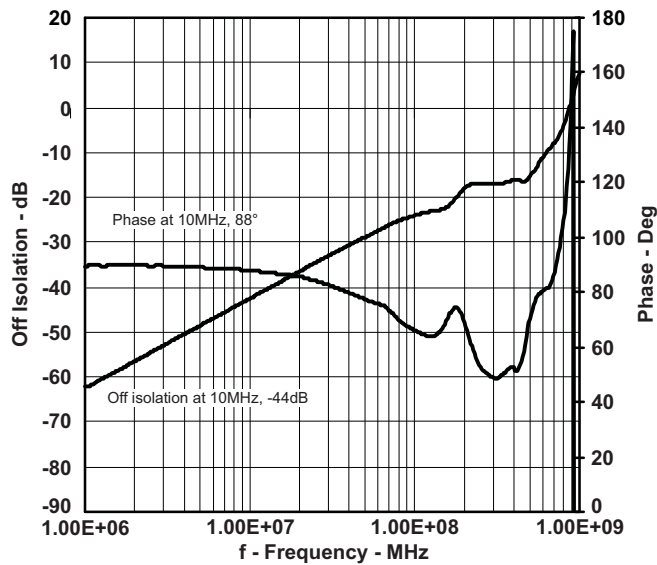

Figure 5. Off Isolation vs Frequency

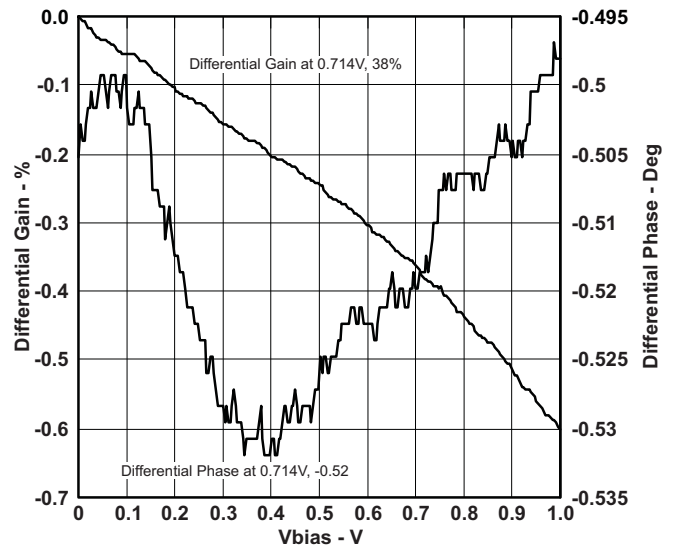

Figure 6. Differential Phase/Gain vs Vbias

Table 3. UNDERSHOOT CHARACTERISTICS (see Figure 7 and Figure 8)

PARAMETER	TEST CONDITIONS			MIN	TYP	MAX	UNIT
VOUTU	V _{CC} = 5.5 V,	Switch OFF,	V _{IN} = V _{CC} or GND	2	V _{OH} - 0.3		V

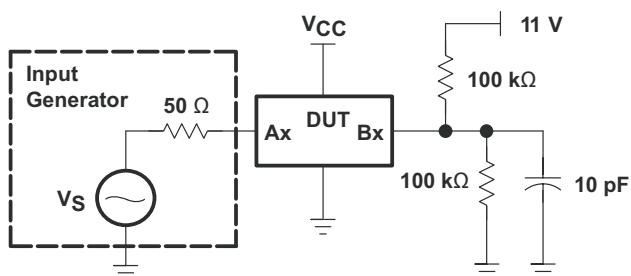

Figure 7. Device Test Setup

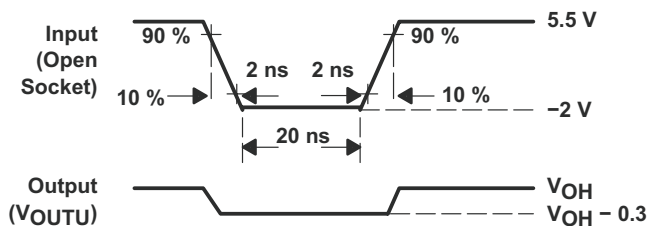
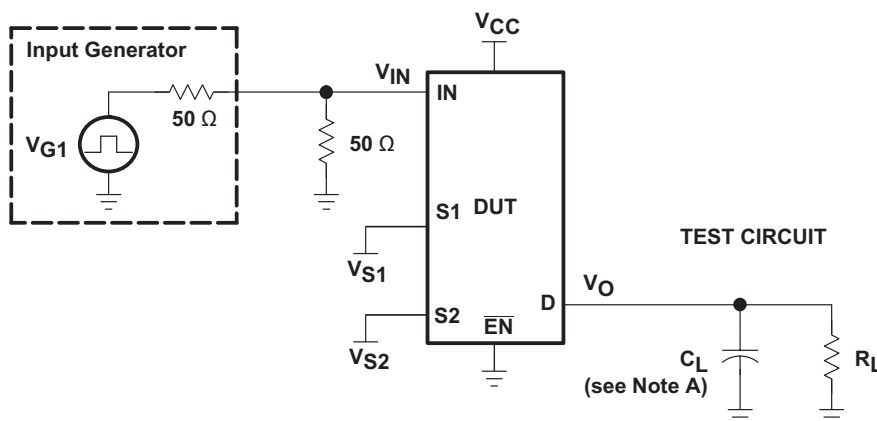

Figure 8. Transient Input Voltage (V) and Output Voltage (V_{OUTU}) Waveforms (Switch OFF)

PARAMETER MEASUREMENT INFORMATION



TEST	V _{CC}	R _L	C _L	V _{S1}	V _{S2}
t _{ON}	5 V ± 0.5 V	75 Ω	20 pF	GND	3 V
	5 V ± 0.5 V	75 Ω	20 pF	3 V	GND
t _{OFF}	5 V ± 0.5 V	75 Ω	20 pF	GND	3 V
	5 V ± 0.5 V	75 Ω	20 pF	3 V	GND

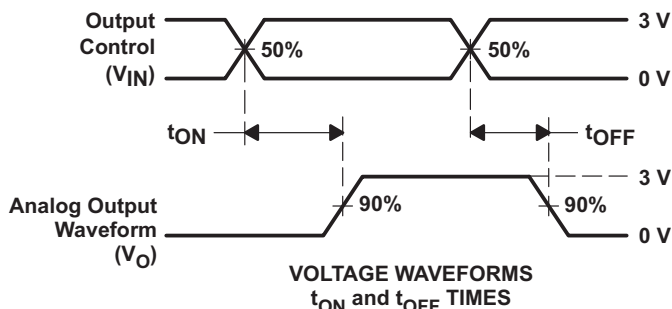
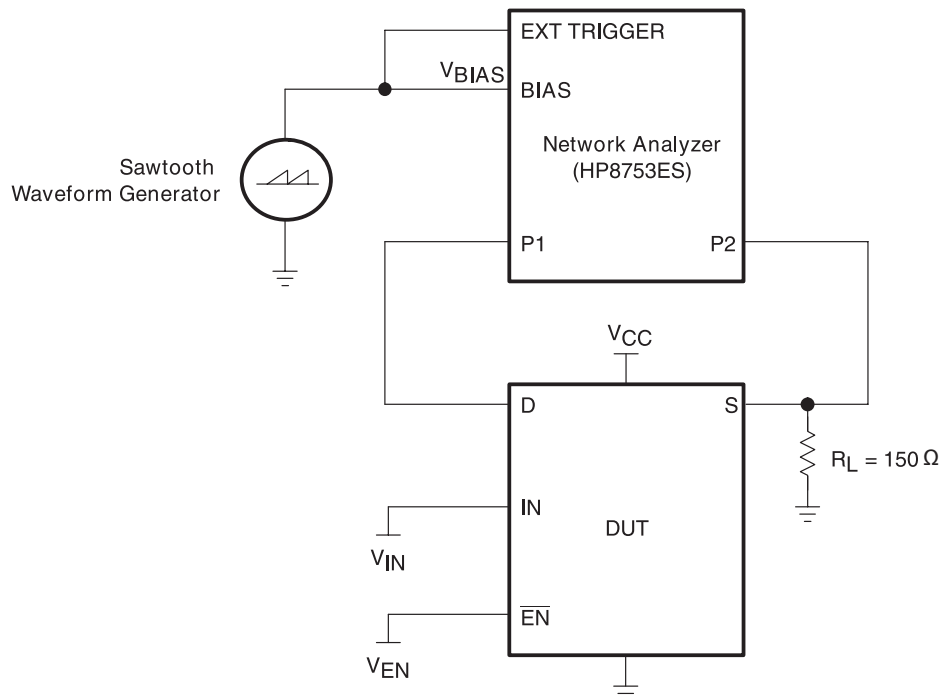

Figure 9. Test Circuit and Voltage Waveforms



For additional information, refer to the TI application report, *Measuring Differential Gain and Phase*, literature number [SLOA040](#).

Figure 10. Test Circuit for Differential Gain/Phase Measurement

The differential gain and phase is measured at the output of the ON channel. For example, when $V_{IN} = 0$, $V_{EN} = 0$, and D_A is the input, the output is measured at S_{1A} .

HP8753ES Setup

Average = 20

RBW = 300 Hz

Smoothing = 2%

$V_{BIAS} = 0$ to 1 V

ST = 1.381 s.

P1 = -7 dBm

CW frequency = 3.58 MHz

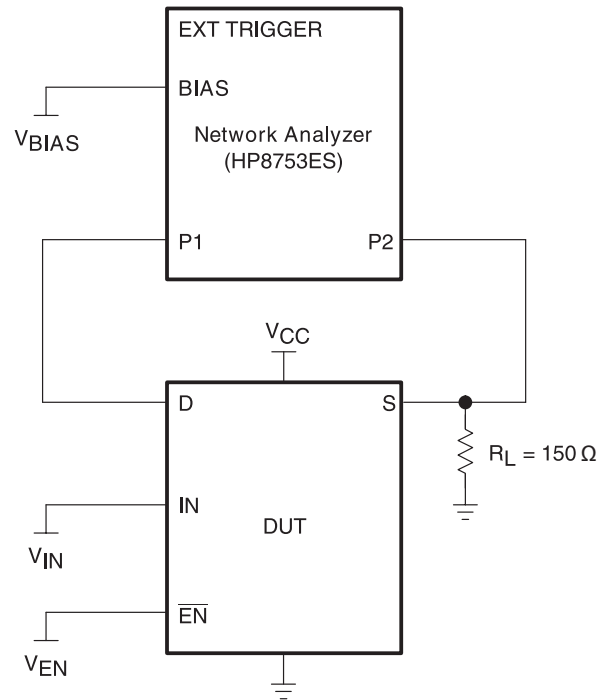

Figure 11. Test Circuit for Frequency Response, Crosstalk, and OFF-Isolation

The frequency response is measured at the output of the ON channel. For example, when $V_{IN} = 0$, $V_{EN} = 0$, and D_A is the input, the output is measured at S_{1A} . All unused analog I/O ports are held at V_{CC} or GND.

The crosstalk is measured at the output of the non-adjacent ON channel. For example, when $V_{IN} = 0$, $V_{EN} = 0$, and D_A is the input, the output is measured at S_{1B} . All unused analog I/O ports are held at V_{CC} or GND.

The off-isolation is measured at the output of the OFF channel. For example, when $V_{IN} = 0$, $V_{EN} = V_{CC}$, and D_A is the input, the output is measured at S_{1A} . All unused analog I/O ports are held at V_{CC} or GND.

HP8753ES Setup

Average = 4

RBW = 3 kHz

Smoothing = 0%

$V_{BIAS} = 0.35$ V

ST = 2 s

P1 = 0 dBm

PACKAGING INFORMATION

Orderable Device	Status (1)	Package Type	Package Drawing	Pins	Package Qty	Eco Plan (2)	Lead/Ball Finish (6)	MSL Peak Temp (3)	Op Temp (°C)	Device Marking (4/5)	Samples
TS5V522CDBQR	ACTIVE	SSOP	DBQ	24	2500	Green (RoHS & no Sb/Br)	NIPDAU	Level-2-260C-1 YEAR	-40 to 85	TS5V522C	Samples
TS5V522CPWR	ACTIVE	TSSOP	PW	24	2000	Green (RoHS & no Sb/Br)	NIPDAU	Level-1-260C-UNLIM	-40 to 85	TE522C	Samples

(1) The marketing status values are defined as follows:

ACTIVE: Product device recommended for new designs.

LIFEBUY: TI has announced that the device will be discontinued, and a lifetime-buy period is in effect.

NRND: Not recommended for new designs. Device is in production to support existing customers, but TI does not recommend using this part in a new design.

PREVIEW: Device has been announced but is not in production. Samples may or may not be available.

OBsolete: TI has discontinued the production of the device.

(2) **RoHS:** TI defines "RoHS" to mean semiconductor products that are compliant with the current EU RoHS requirements for all 10 RoHS substances, including the requirement that RoHS substance do not exceed 0.1% by weight in homogeneous materials. Where designed to be soldered at high temperatures, "RoHS" products are suitable for use in specified lead-free processes. TI may reference these types of products as "Pb-Free".

RoHS Exempt: TI defines "RoHS Exempt" to mean products that contain lead but are compliant with EU RoHS pursuant to a specific EU RoHS exemption.

Green: TI defines "Green" to mean the content of Chlorine (Cl) and Bromine (Br) based flame retardants meet JS709B low halogen requirements of <=1000ppm threshold. Antimony trioxide based flame retardants must also meet the <=1000ppm threshold requirement.

(3) MSL, Peak Temp. - The Moisture Sensitivity Level rating according to the JEDEC industry standard classifications, and peak solder temperature.

(4) There may be additional marking, which relates to the logo, the lot trace code information, or the environmental category on the device.

(5) Multiple Device Markings will be inside parentheses. Only one Device Marking contained in parentheses and separated by a "~" will appear on a device. If a line is indented then it is a continuation of the previous line and the two combined represent the entire Device Marking for that device.

(6) Lead/Ball Finish - Orderable Devices may have multiple material finish options. Finish options are separated by a vertical ruled line. Lead/Ball Finish values may wrap to two lines if the finish value exceeds the maximum column width.

Important Information and Disclaimer:The information provided on this page represents TI's knowledge and belief as of the date that it is provided. TI bases its knowledge and belief on information provided by third parties, and makes no representation or warranty as to the accuracy of such information. Efforts are underway to better integrate information from third parties. TI has taken and continues to take reasonable steps to provide representative and accurate information but may not have conducted destructive testing or chemical analysis on incoming materials and chemicals. TI and TI suppliers consider certain information to be proprietary, and thus CAS numbers and other limited information may not be available for release.

In no event shall TI's liability arising out of such information exceed the total purchase price of the TI part(s) at issue in this document sold by TI to Customer on an annual basis.

TAPE AND REEL INFORMATION



QUADRANT ASSIGNMENTS FOR PIN 1 ORIENTATION IN TAPE



*All dimensions are nominal

Device	Package Type	Package Drawing	Pins	SPQ	Reel Diameter (mm)	Reel Width W1 (mm)	A0 (mm)	B0 (mm)	K0 (mm)	P1 (mm)	W (mm)	Pin1 Quadrant
TS5V522CDBQR	SSOP	DBQ	24	2500	330.0	16.4	6.5	9.0	2.1	8.0	16.0	Q1
TS5V522CPWR	TSSOP	PW	24	2000	330.0	16.4	6.95	8.3	1.6	8.0	16.0	Q1

TAPE AND REEL BOX DIMENSIONS

*All dimensions are nominal

Device	Package Type	Package Drawing	Pins	SPQ	Length (mm)	Width (mm)	Height (mm)
TS5V522CDBQR	SSOP	DBQ	24	2500	367.0	367.0	38.0
TS5V522CPWR	TSSOP	PW	24	2000	367.0	367.0	38.0

DBQ (R-PDSO-G24)

PLASTIC SMALL-OUTLINE PACKAGE

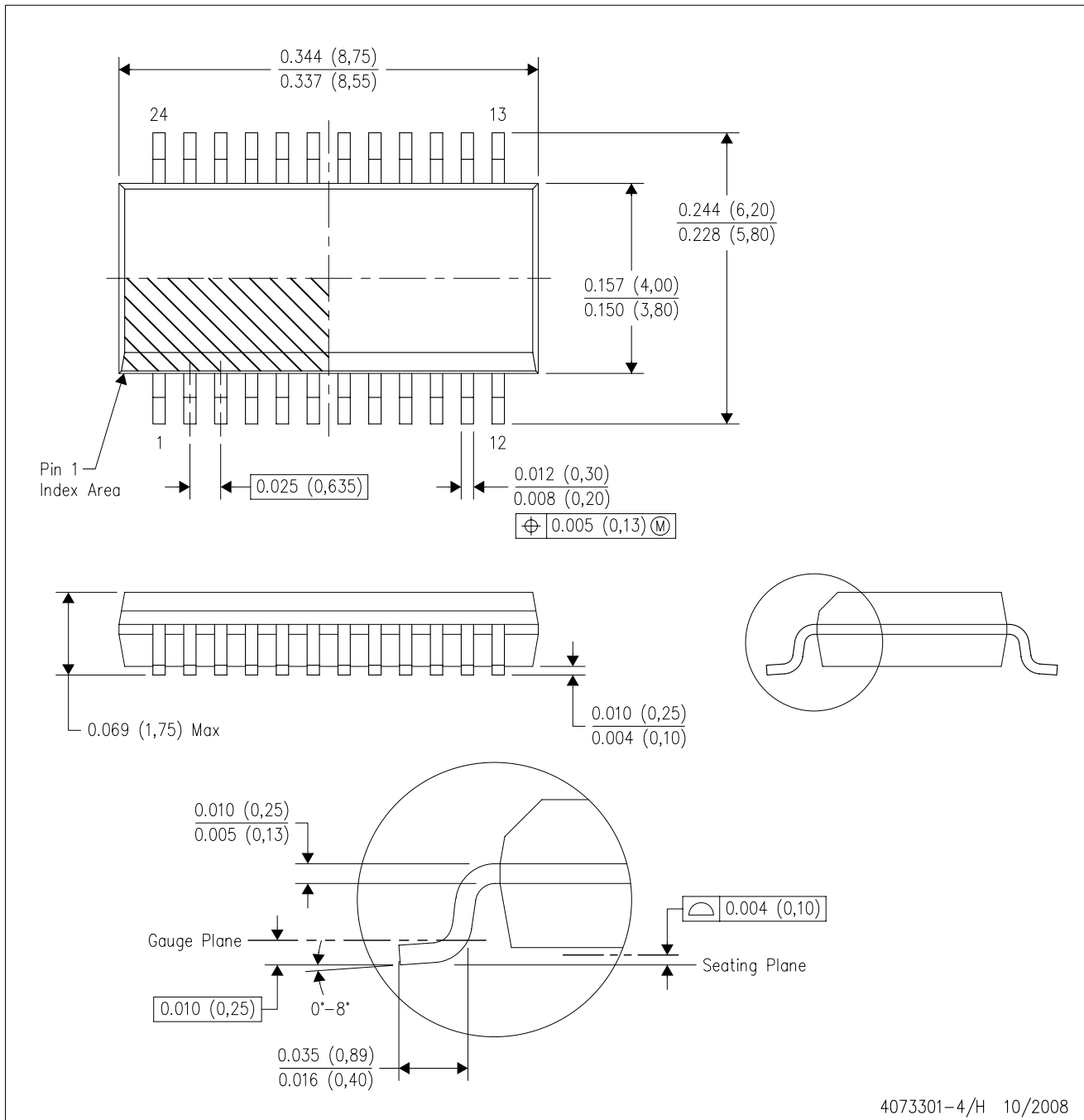

- NOTES:
- A. All linear dimensions are in inches (millimeters).
 - B. This drawing is subject to change without notice.
 - C. Body dimensions do not include mold flash or protrusion not to exceed 0.006 (0,15) per side.
 - D. Falls within JEDEC MO-137 variation AE.

PW0024A

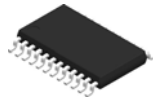

PACKAGE OUTLINE

TSSOP - 1.2 mm max height

SMALL OUTLINE PACKAGE

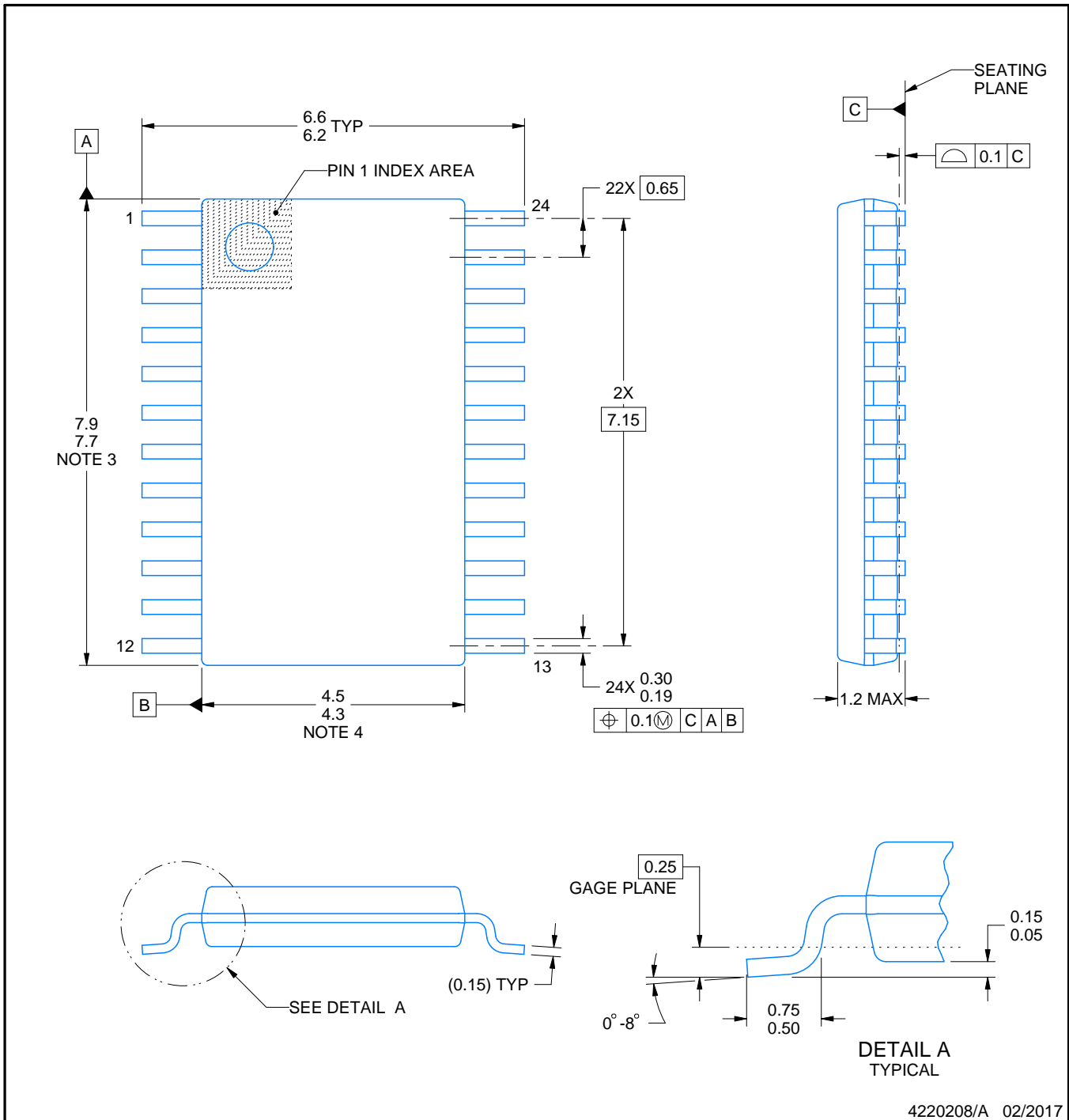

4220208/A 02/2017

NOTES:

1. All linear dimensions are in millimeters. Any dimensions in parenthesis are for reference only. Dimensioning and tolerancing per ASME Y14.5M.
2. This drawing is subject to change without notice.
3. This dimension does not include mold flash, protrusions, or gate burrs. Mold flash, protrusions, or gate burrs shall not exceed 0.15 mm per side.
4. This dimension does not include interlead flash. Interlead flash shall not exceed 0.25 mm per side.
5. Reference JEDEC registration MO-153.

EXAMPLE BOARD LAYOUT

PW0024A

TSSOP - 1.2 mm max height

SMALL OUTLINE PACKAGE



LAND PATTERN EXAMPLE
EXPOSED METAL SHOWN
SCALE: 10X



SOLDER MASK DETAILS

4220208/A 02/2017

NOTES: (continued)

6. Publication IPC-7351 may have alternate designs.
7. Solder mask tolerances between and around signal pads can vary based on board fabrication site.

EXAMPLE STENCIL DESIGN

PW0024A

TSSOP - 1.2 mm max height

SMALL OUTLINE PACKAGE



NOTES: (continued)

8. Laser cutting apertures with trapezoidal walls and rounded corners may offer better paste release. IPC-7525 may have alternate design recommendations.
9. Board assembly site may have different recommendations for stencil design.

IMPORTANT NOTICE AND DISCLAIMER

TI PROVIDES TECHNICAL AND RELIABILITY DATA (INCLUDING DATASHEETS), DESIGN RESOURCES (INCLUDING REFERENCE DESIGNS), APPLICATION OR OTHER DESIGN ADVICE, WEB TOOLS, SAFETY INFORMATION, AND OTHER RESOURCES "AS IS" AND WITH ALL FAULTS, AND DISCLAIMS ALL WARRANTIES, EXPRESS AND IMPLIED, INCLUDING WITHOUT LIMITATION ANY IMPLIED WARRANTIES OF MERCHANTABILITY, FITNESS FOR A PARTICULAR PURPOSE OR NON-INFRINGEMENT OF THIRD PARTY INTELLECTUAL PROPERTY RIGHTS.

These resources are intended for skilled developers designing with TI products. You are solely responsible for (1) selecting the appropriate TI products for your application, (2) designing, validating and testing your application, and (3) ensuring your application meets applicable standards, and any other safety, security, or other requirements. These resources are subject to change without notice. TI grants you permission to use these resources only for development of an application that uses the TI products described in the resource. Other reproduction and display of these resources is prohibited. No license is granted to any other TI intellectual property right or to any third party intellectual property right. TI disclaims responsibility for, and you will fully indemnify TI and its representatives against, any claims, damages, costs, losses, and liabilities arising out of your use of these resources.

TI's products are provided subject to TI's Terms of Sale (www.ti.com/legal/termsofsale.html) or other applicable terms available either on ti.com or provided in conjunction with such TI products. TI's provision of these resources does not expand or otherwise alter TI's applicable warranties or warranty disclaimers for TI products.

Mailing Address: Texas Instruments, Post Office Box 655303, Dallas, Texas 75265
Copyright © 2020, Texas Instruments Incorporated