

Features

- 16-/32-bit Data and Address Register
- 16-Mbyte Direct Addressing Range
- 56 Powerful Instruction Types
- Operations on Five Main Data Types
- Memory Mapped Input/Output
- 14 Addressing Modes
- Three Available Versions: 8 MHz/10 MHz and 12.5 MHz
- Military Temperature Range: -55/+125°C
- Power Supply: $5V_{DC} \pm 10\%$

Description

The TS68C000 reduced power consumption device dissipates an order of magnitude less power than the HMOS TS68000. The TS68C000 is an implementation of the TS68000 16/32 microprocessor architecture. The TS68C000 has a 16-bit data bus and 24-bit address bus while the full architecture provides for 32-bit address and data-buses. It is completely code-compatible with the HMOS TS68000, TS68008 8-bit data bus implementation of the TS68000 and the TS68020 32-bit implementation of the architecture. Any user-mode programs written using the TS68C000 instruction set will run unchanged on the TS68000, TS68008 and TS68020. This is possible because the user programming model is identical for all processors and the instruction sets are proper sub-sets of the complete architecture.

Screening/Quality

This product is manufactured in full compliance with:

- MIL-STD-883 class B
- DESC drawing 5962-89462
- Atmel standards

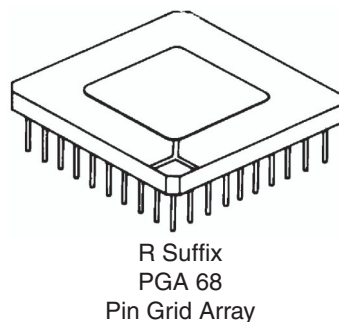
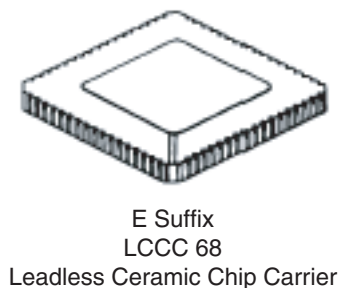
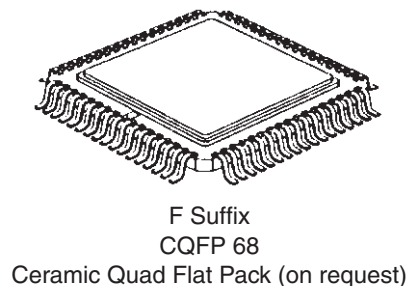
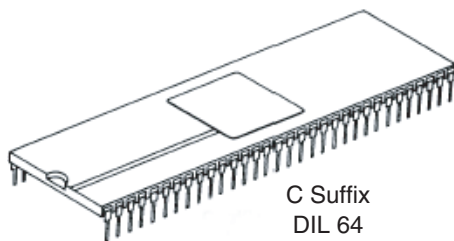

Low Power HCMOS 16-/32-bit Hi-Rel Microprocessor

TS68C000

Rev. 2170A-HIREL-09/05



1. General Description

1.1 Introduction

This detail specification contains both a summary of the TS68C000 as well as detailed set of parametrics. The purpose is twofold to provide an instruction to the TS68C000 and support for the sophisticated user. For detail information on the TS68C000, refer to "68000 16-bit microprocessor user's manual".

1.2 Detailed Block Diagram

The functional block diagram is given in [Figure 1-1](#) below.

Figure 1-1. Block Diagram

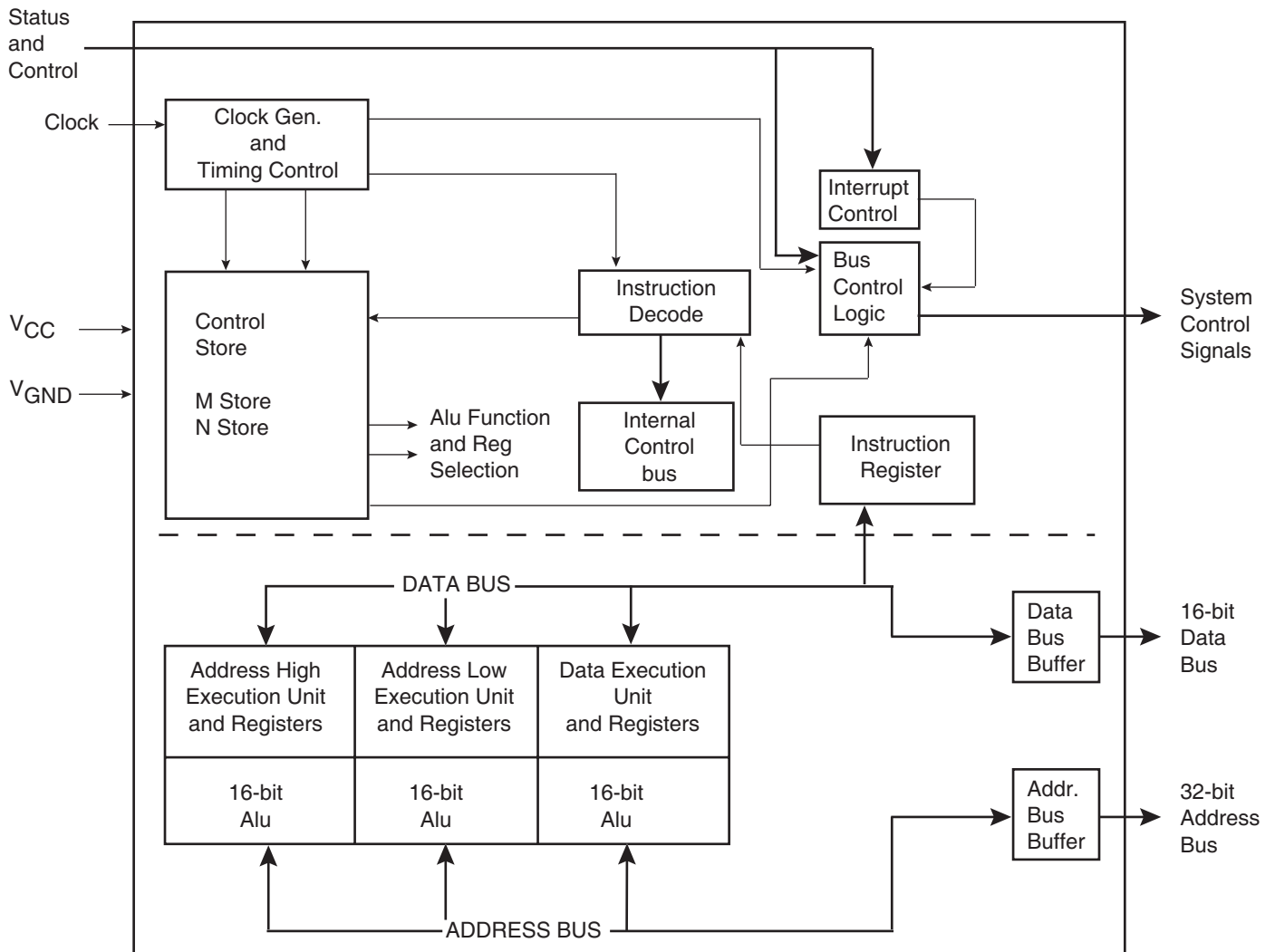

1.3 Pin Assignments

Figure 1-2. 64-lead Dual-in-Line Package

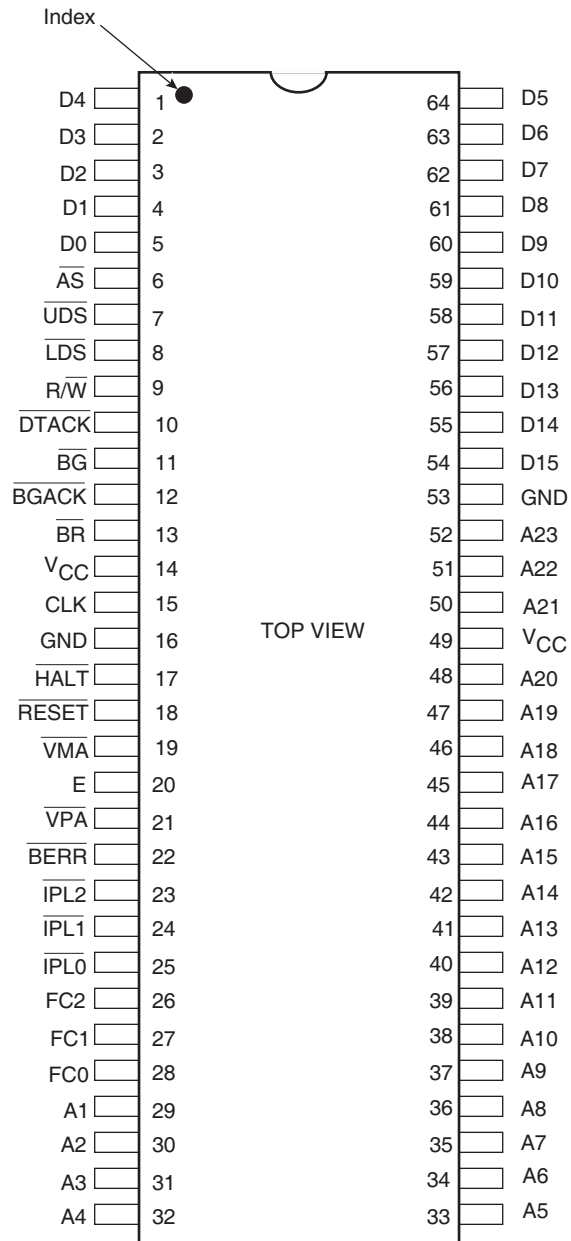

Figure 1-3. 68-terminal Pin Grid Array

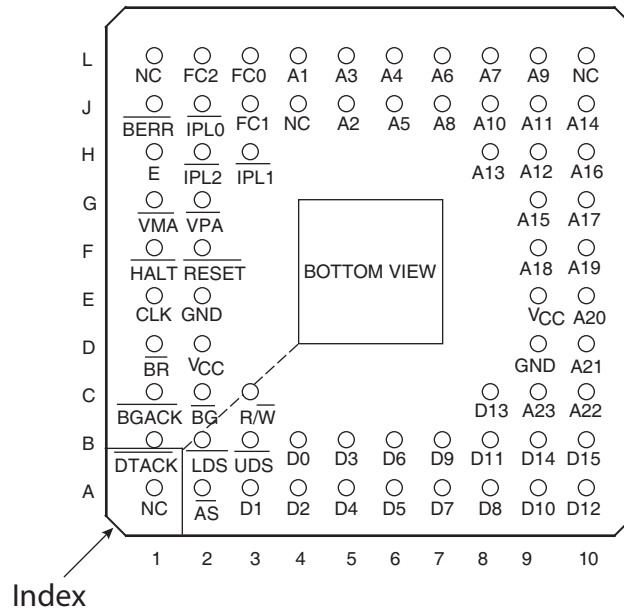

Figure 1-4. 68-lead Quad Pack

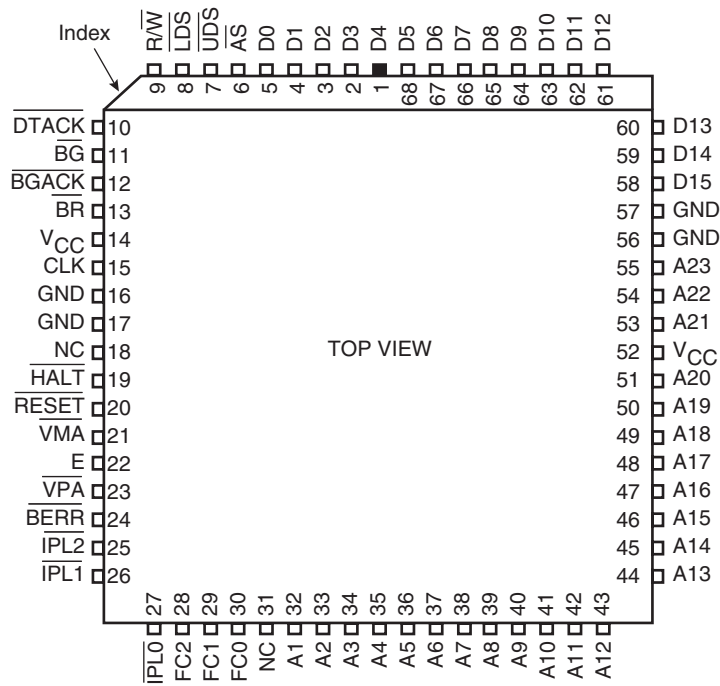
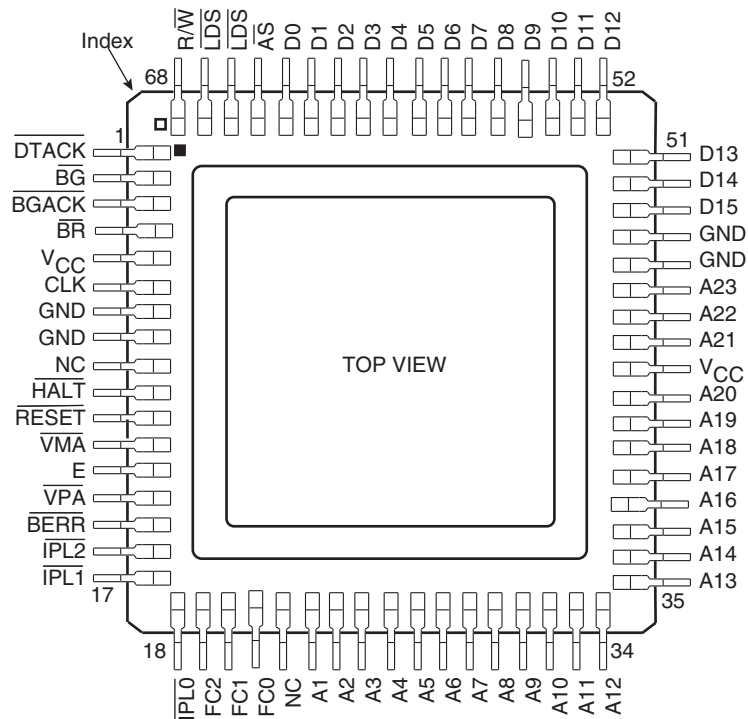

Figure 1-5. 68-ceramic Quad Flat Pack



1.4 Terminal Designations

The function, category and relevant symbol of each terminal of the device are given in the following table.

Table 1-1. Terminal Designations

Symbol	Function	Category
V _{CC}	Power supply (2 terminals)	Supply
V _{SS} ⁽¹⁾	Power supply (2 terminals)	Terminals
FC0 to FC2	Processor status	Outputs
$\overline{\text{IPL0}}$ to $\overline{\text{IPL2}}$	Interrupt control	Inputs
A1 to A23	Address bus	Outputs
AS	Asynchronous bus control	Outputs
R/ $\overline{\text{W}}$		
$\overline{\text{UDS}}$		
$\overline{\text{LDS}}$		
$\overline{\text{DTACK}}$		Input
$\overline{\text{BR}}$	Bus arbitration control	Inputs
$\overline{\text{BGACK}}$		
$\overline{\text{BG}}$		Output

Table 1-1. Terminal Designations (Continued)

Symbol	Function	Category
$\overline{\text{BERR}}$	System control	Input
$\overline{\text{RESET}}$		Input/Output
$\overline{\text{HALT}}$		
$\overline{\text{VPA}}$	6800 peripheral control	Input
$\overline{\text{VMA}}$		Output
E		Output
CLK	Clock	Input
D0 to D15	Data bus	Input/Output

Note: 1. V_{SS} is the reference terminal for the voltages

1.5 Signal Description

The input and output signals are illustrated functionally in Figure 1-6 and are described in the following paragraphs.

Figure 1-6. Input and Output Signals

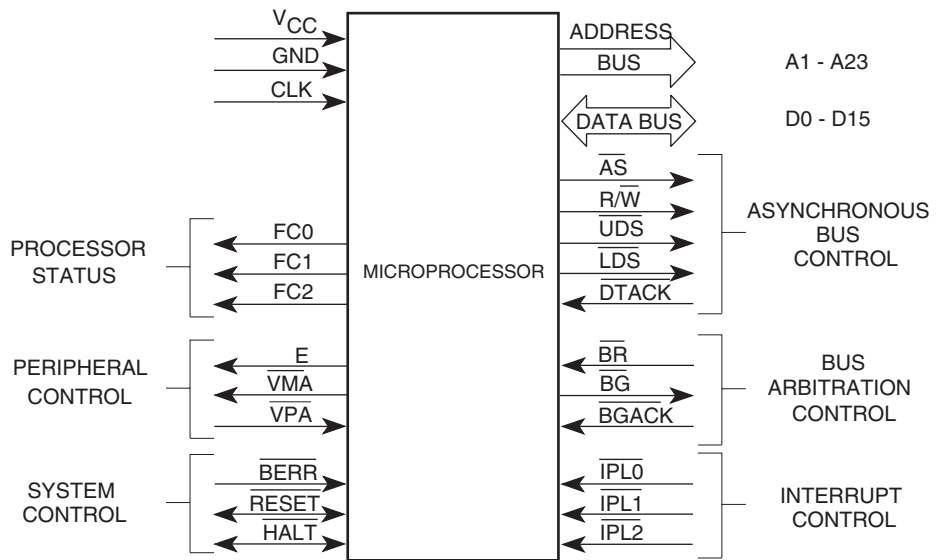

Table 1-2. Data Strobe Control of Data Bus

$\overline{\text{UDS}}$	$\overline{\text{LDS}}$	R/W	D8-D15	D0-D7
High	High		No valid data	No valid data
Low	Low	High	Valid data bits 8-15	Valid data bits 0-7
High	Low	High	No valid data	Valid data bits 0-7
Low	High	High	Valid data bits 8-15	No valid data
Low	Low	Low	Valid data bits 8-15	Valid data bits 0-7
High	Low	Low	Valid data bits 0-7	Valid data bits 0-7
Low	High	High	Valid data bits 8-15	Valid data bits 8-15

1.5.0.1 Address Bus (A1 through A23)

This 24-bit, unidirectional, three-state bus is capable of addressing 16 megabytes of data. It provides the address for bus operation during all cycles except interrupt cycles. During interrupt cycles, address lines A1, A2 and A3 provide information about what level interrupt is being serviced while address lines A4 through A23 are set to a logic high.

1.5.0.2 Data Bus (D0 Through D15)

This 16-bit, bidirectional, three-state bus is the general-purpose data path. It can transfer and accept data in either word or byte length. During an interrupt acknowledge cycle, the external device supplies the vector number on data lines D0-07.

1.5.0.3 Asynchronous Bus Control

Asynchronous data transfers are handled using the following control signals: address strobe, read/write, upper and lower data strobes, and data transfer acknowledge. These signals are explained in the following paragraphs.

ADDRESS STROBE (\overline{AS})

This signal indicates that there is a valid address on the address bus.

READ/WRITE (R/\overline{W})

This signal defines the data bus transfer as a read or write cycle. The R/\overline{W} signal also works in conjunction with the data strobes as explained in the following paragraph.

UPPER AND LOWER DATA STROBE (\overline{UDS} , \overline{LDS})

These signals control the flow of data on the data bus, as shown in [Table 1-2](#). When the R/\overline{W} line is high, the processor will read from the data bus as indicated. When the R/\overline{W} line is low, the processor will write to the data bus as shown.

DATA TRANSFER ACKNOWLEDGE (\overline{DTACK})

This input indicates that the data transfer is completed. When the processor recognizes \overline{DTACK} during a read cycle, data is latched and the bus cycle terminated. When \overline{DTACK} is recognized during a write cycle, the bus cycle is terminated.

1.5.0.4 Bus Arbitration Control

The three signals, bus request, bus grant, and bus grant acknowledge, form a bus arbitration circuit to determine which device will be the bus master device.

BUS REQUEST (\overline{BR})

This input is wire ORed with all other devices that could be bus masters. This input indicates to the processor that some other device desires to become the bus master.

BUS GRANT (\overline{BG})

This output indicates to all other potential bus master devices that the processor will release bus control at the end of the current bus cycle.

BUS GRANT ACKNOWLEDGE (\overline{BGACK})

This input indicates that some other device has become the bus master.

This signal should not be asserted until the following four conditions are met:

1. a bus grant has been received,
2. address strobe is inactive which indicates that the microprocessor is not using the bus,
3. data transfer acknowledge is inactive which indicates that neither memory nor peripherals are using the bus, and
4. bus grant acknowledge is inactive which indicates that no other device is still claiming bus mastership.

1.5.0.5 *Interrupt Control ($\overline{IPL0}$, $\overline{IPL1}$, $\overline{IPL2}$)*

These Input pins indicate the encoded priority level of the device requesting an interrupt. Level seven is the highest priority while level zero indicates that no interrupts are requested. Level seven cannot be masked. The least significant bit is given in $\overline{IPL0}$ and the most significant bit is contained in $\overline{IPL2}$. These lines must remain stable until the processor signals interrupt acknowledge (FC0-FC2 are all high) to insure that the interrupt is recognized.

1.5.0.6 *System Control*

The system control inputs are used to either reset or halt the processor and to indicate to the processor that bus errors have occurred. The three system control inputs are explained in the following paragraphs.

BUS ERROR (\overline{BERR})

This input informs the processor that there is a problem with the cycle currently being executed. Problems may be a result of:

1. nonresponding devices,
2. interrupt vector number acquisition failure,
3. illegal access request as determined by a memory management unit, or
4. other application dependent errors.

The bus error signal interacts with the halt signal to determine if the current bus cycle should be re-executed or if exception processing should be performed.

RESET (\overline{RESET})

This bidirectional signal line acts to reset (start a system initialization sequence) to processor in response to an external reset signal. An internally generated reset (result of a \overline{RESET} instruction) causes all external devices to be reset and the internal of the processor is not affected. A total system reset (processor and external devices) is the result of external \overline{HALT} and \overline{RESET} signals applied at the same time.

HALT (\overline{HALT})

When this bidirectional line is driven by an external device, it will cause the processor to stop at the completion of the current bus cycle. When the processor has been halted using this input, all control signals are inactive and all three-state lines are put in their high-impedance state.

When the processor has stopped executing Instructions, such as in a double bus fault condition, the \overline{HALT} line is driven by the processor to indicate to external devices that the processor has stopped.

1.5.0.7 EF 6800 Peripheral Control

These control signals are used to allow the interfacing of synchronous EF 6800 peripheral devices with the asynchronous TS68C000. These signals are explained in the following paragraphs.

ENABLE (E)

This signal is the standard enable signal common to all EF 6800 type peripheral devices. The period for this output is ten TS68C000 clock periods (six clocks low, four clocks high). Enable is generated by an internal ring counter which may come up in any state (i.e., at power on, it is impossible to guarantee phase relationship of E to CLK). E is a free-running crack and runs regardless of the state of the bus on the MPU.

VALID PERIPHERAL ADDRESS (\overline{VPA})

This input indicates that the device or region addressed is an TS68000 Family device and that data transfer should be synchronized with the enable (E) signal. This Input also indicates that the processor should use automatic vectoring for an interrupt during an IACK cycle.

VALID MEMORY ADDRESS (\overline{VMA})

This output is used to indicate to TS68000 peripheral devices that there is a valid address on the address bus and the processor is synchronized to enable. This signal only responds to a valid peripheral address (\overline{VPA}) input which indicates that the peripheral is an TS68000 Family device.

1.5.0.8 Processor Status (FC0, FC1, FC2)

These function code outputs indicate the state (user or supervisor) and the cycle type currently being executed, as shown in [Table 1-3](#). The information indicated by the function code outputs is valid whenever address strobe (\overline{AS}) is active.

Table 1-3. Processor Status Table

Function Code Output			Cycle Time
FC2	FC1	FC0	
Low	Low	Low	(Undefined, reserved)
Low	Low	High	User data
Low	High	Low	User program
Low	High	High	(Undefined, reserved)
High	Low	Low	(Undefined, reserved)
High	Low	High	Supervisor data
High	High	Low	Supervisor program
High	High	High	Interrupt acknowledge

1.5.0.9 Clock (CLK)

The clock input is a TTL-compatible signal that is internally buffered for development of the internal clocks needed by the processor. The clock input should not be gated off at any time and the clock signal must conform to minimum and maximum pulse width times. The clock is a constant frequency square wave with no stretching or shaping techniques required.

2. Detailed Specifications

2.1 Scope

This drawing describes the specific requirements for the microprocessor TS68C000, 8 MHz, 10 MHz and 12.5 MHz, in compliance with MIL-STD-883 class B.

2.2 Applicable Documents

2.2.1 MIL-STD-883

1. MIL-STD-883: Test Methods and Procedures For Electronics
2. MIL-PRF-38535 Appendix A: General Specifications for Microcircuits

2.3 Requirements

2.3.1 General

The microcircuits are in accordance with the applicable document and as specified herein.

2.4 Design and Construction

2.4.1 Terminal Connections

Depending on the package, the terminal connections shall be as shown in [Figure 1-2](#), [Figure 1-3](#), [Figure 1-4](#) and [Figure 1-5](#).

2.4.2 Lead Material and Finish

Lead material and finish shall be any option of MIL-PRF-38535 Appendix A-3-5-6 "Package Element Material and Finish".

2.4.3 Package

The macrocircuits are packaged in hermetically sealed ceramic package which is conform to case outlines of MIL-PRF-38535 Appendix A-3-5-1.

- PGA68 64 LEAD DIP
- 64 DILSQ. LCC 68 PINS
- 68 LCCC68 TERMINALS JCC
- 68 CQFP

The precise case outlines are described on figures and into MIL-M-38510.

2.4.4 Electrical Characteristics

2.4.4.1 Absolute Maximum Ratings

Limiting conditions (ratings) defined below shall not be for inspection purposes. However some limiting conditions (ratings) may be taken in other parts of this specification as detail conditions for an applicable test.

Unless otherwise stated, all voltages are referenced to the reference terminal as defined in [Table 1-1](#), "Terminal Designations" on page 5 of this specification.

Table 2-1. Absolute Maximum Ratings

Symbol	Parameter	Test Conditions	Min	Max	Unit
V_{CC}	Supply voltage		-0.3	+6.5	V
V_i	Input voltage		-0.3	+6.5	V
V_o	Output voltage		NA	NA	V
V_{OZ}	Off state voltage		-0.3	11.0	V
I_o	Output currents		NA	NA	mA
I_i	Input currents		NA	NA	mA
P_{DMAX}	Max power dissipation	$T_{CASE} = -55^{\circ}C$		0.27	W
		$T_{CASE} = +125^{\circ}C$		0.27	W
T_{STG}	Storage temperature		-55	+150	$^{\circ}C$
T_J	Junction temperature			+150	$^{\circ}C$
T_{LEADS}	Lead temperature	Max 5 sec. Soldering		+270	$^{\circ}C$

2.4.4.2 Recommended Condition of Use and Guaranteed Characteristics

- Guaranteed Characteristics ([Table 2-5](#) and [Table 2-8](#))

The characteristics associated to a specified measurement in the detail specification shall only be for inspection purposes.

Such characteristic defined in this specification is guaranteed only under the conditions and within the limits which are specified for the relevant measurement. Unless otherwise specified, this guarantee applies within all the recommended operating ranges specified below.

- Recommended conditions of use ([Table 2-2](#))

To the correct operation of the device, the conditions of use shall be within the ranges specified below (see also above).

These conditions shall not be for inspection purposes.

Some recommended values may, however, be taken in other parts of this specification as detail conditions for an applicable test ([Table 2-9](#)).

- Additional Electrical Characteristics ([Table 2-9](#)), see "[Additional Electrical Characteristics](#)" on [page 30](#).

Figure 2-1. Clock Input Timing Diagram

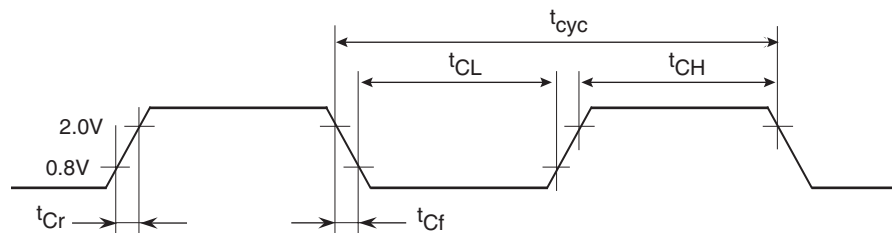

Note: Timing measurements are referenced to and from a low voltage of 0.8V and a high voltage of 2.0V, unless otherwise noted. The voltage swing through this range should start outside, and pass through, the range such that the rise of fall will be linear between 0.8V and 2.0V.

Unless otherwise stated, all voltages are referenced to the reference terminal (see [Table 1-1](#)).

Table 2-2. Recommended Condition of Use

Symbol	Parameter	Operating Range			
		Model	Min	Max	Unit
V_{CC}	Supply voltage	All	4.5	5.5	V
V_{IL}	Low level input voltage	All	0	0.8	V
V_{IH}	High level input voltage (see also "Package" on page 10)	All	2.0	V_{CC}	V
T_{CASE}	Operating temperature	All	-55	+125	°C
R_L	Value of output load resistance	All	(1)		Ω
C_L	Output loading capacitance	All		(1)	pF
$t_{r(c)}$	Clock rise time (see Figure 2-1)	All		10	ns
$t_{f(c)}$	Clock fall time (see Figure 2-1)	All		10	ns
f_C	Clock frequency (see Figure 2-1)	TS68C000-8	4.0	8.0	MHz
		TS68C000-10	4.0	10.0	MHz
		TS68C000-12	4.0	12.5	MHz
t_{CYC}	Clock time (see Figure 2-1)	TS68C000-8	125	250	ns
		TS68C000-10	100	250	ns
		TS68C000-12	80	250	ns
$t_{W(CL)}$	Clock pulse width low (see Figure 2-1)	TS68C000-8	55	125	ns
		TS68C000-10	45	125	ns
		TS68C000-12	35	125	ns
$t_{W(CH)}$	Cycle pulse width high (see Figure 2-1)	TS68C000-8	55	125	ns
		TS68C000-10	45	125	ns
		TS68C000-12	35	125	ns

Note: 1. Load networks number 1 to 4 as specified in "Test Conditions Specific to the Device" on page 26 (Figure 2-2 and Figure 2-3) gives the maximum loading for the relevant output.

2.4.4.3 Special Recommended Conditions for CMOS Devices

1. CMOS Latch-up

The CMOS cell is basically composed of two complementary transistors (a P-channel and an N-channel), and, in the steady state, only one transistor is turned-on. The active P-channel transistor sources current when the output is a logic high and presents a high impedance when the output is a logic low. Thus the overall result is extremely low power consumption because there is no power loss through the active P-channel transistor. Also since only once transistor is determined by leakage currents.

Because the basic CMOS cell is composed of two complementary transistors, a virtual semiconductor controlled rectifier (SCR) may be formed when an input exceeds the supply voltage. The SCR that is formed by this high input causes the device to become "latched" in a mode that may result in excessive current drain and eventual destruction of the device. Although the device is Implemented with input protection diodes, care should be exercised to ensure that the maximum input voltages specification is not exceeded tram voltage transients; others may require no additional circuitry.

2. CMOS Applications

- The TS68C000 completely satisfies the input/output drive requirements of CMOS logic devices.
- The HCMOS TS68C000 provides an order of magnitude power dissipation reduction when compared to the HMOS TS68000. However, the TS68C000 does not offer a "power down" or "halt" mode. The minimum operating frequency of the TS68C000 is 4 MHz.

2.4.5 Thermal Characteristics

Table 2-3. Thermal Characteristics

Package	Symbol	Parameter	Value	Unit
DIL 64	θ_{JA}	Thermal resistance junction to ambient	25	°C/W
	θ_{JC}	Thermal resistance junction to case	6	°C/W
PGA 68	θ_{JA}	Thermal resistance junction to ambient	30	°C/W
	θ_{JC}	Thermal resistance junction to case	6	°C/W
LCCC 68	θ_{JA}	Thermal resistance junction to ambient	40	°C/W
	θ_{JC}	Thermal resistance junction to case	8	°C/W
CQFP 68	θ_{JA}	Thermal resistance junction to ambient	40	°C/W
	θ_{JC}	Thermal resistance junction to case	10	°C/W

2.4.5.1 Power Considerations

The average chip-junction temperature, T_J , in °C can be obtained from:

$$T_J = T_A + (P_D \cdot \theta_{JA}) \quad (1)$$

T_A = Ambient Temperature, °C

θ_{JA} = Package Thermal Resistance, Junction-to-Ambient, °C/W

$$P_D = P_{INT} + P_{I/O}$$

$P_{INT} = I_{CC} \times V_{CC}$, Watts – Chip Internal Power

$P_{I/O}$ = Power Dissipation on Input and Output Pins – User Determined

For most applications $P_{I/O} < P_{INT}$ and can be neglected.

An Approximate relationship between P_D and T_J (if $P_{I/O}$ is neglected) is:

$$P_D = K: (T_J + 273) \quad (2)$$

Solving equations (1) and (2) for K gives:

$$K = P_D \cdot (T_A + 273) + \theta_{JA} \cdot P_D^2 \quad (3)$$

where K is constant pertaining to the particular part K can be determined from the equation (3) by measuring PD (at equilibrium) for a known T_A . Using this value of K, the values of P_D and T_J can be obtained by solving equations (1) and (2) iteratively for any value of T_A .

The total thermal resistance of a package (θ_{JA}) can be separated into two components, θ_{JC} and θ_{CA} , representing the barrier to heat flow from the semiconductor junction to the package (case), surface (θ_{JC}) and from the case to the outside ambient (θ_{CA}).

These terms are related by the equation:

$$\theta_{JA} = \theta_{JC} + \theta_{CA} \quad (4)$$

θ_{JA} is device related and cannot be influenced by the user. However, θ_{CA} is user dependent and can be minimized by such thermal management techniques as heat sinks, ambient air cooling and thermal convection. Thus, good thermal management on the part of the user can significantly reduce θ_{CA} so that θ_{JA} approximately equals θ_{JC} . Substitution of θ_{JC} for θ_{JA} in equation (1) will result in a lower semiconductor junction temperature.

2.4.6 Mechanical and Environmental

The microcircuits shall meet all mechanical environmental requirements of MIL-STD-883 for class B devices.

2.4.7 Marking

The document where are defined the marking are identified in the related reference documents. Each microcircuit is legible and permanently marked with the following information as minimum:

- Atmel Logo
- Manufacturer's Part Number
- Class B Identification
- Date-code of inspection lot
- ESD Identifier if Available
- Country of Manufacturing

2.5 Quality Conformance Inspection

2.5.1 DESC/MIL-STD-883

Is in accordance with MIL-PRF-38535 and method 5005 of MIL-STD-883. Group A and B inspections are performed on each production lot. Group C and D inspection are performed on a periodical basis.

2.6 Electrical Characteristics

2.6.1 General Requirements

All static and dynamic electrical characteristics specified for inspection purposes and the relevant measurements conditions are given below:

- [Table 2-4](#): Static Electrical Characteristics for all electrical variants.
- [Table 2-5](#), [Table 2-6](#), [Table 2-7](#) and [Table 2-8](#): Dynamic electrical characteristics for 8 MHz, 10 MHz and 12.5 MHz.

For static characteristics ([Table 2-4](#)), test methods refer to IEC 748-2 method number, where existing.

For dynamic characteristics, test methods refer to clause "[Test Conditions Specific to the Device](#)" on page 26 of this specification ([Table 2-5](#), [Table 2-6](#), [Table 2-7](#) and [Table 2-8](#)).

Indication of "min" or "max" in the column "test temperature" means minimum or maximum operating temperatures as defined in sub-clause "[Recommended Condition of Use and Guaranteed Characteristics](#)" on page 11 here above.

Table 2-4. Static Characteristics
 $V_{CC} = 5.0V$ $V_{DC} \pm 10\%$; $GND = 0 V_{DC}$; $T_c = -55/+125^{\circ}C$ and $-40^{\circ}C/+85^{\circ}C$

Test Number	Symbol	Parameter	Ref Number (**)	Test Conditions	Test Temperature	Limits		Unit
						Min (*)	Max (*)	
1	I_{CC}	Supply current	41	$V_{CC} = 5.5V$ $F_C = 8\text{ MHz}$ $F_C = 10\text{ MHz}$ $F_C = 12\text{ MHz}$	All		42 45 50	mA
2	$V_{OL}^{(1)}$	Low level output voltage for: A1 to A23 FC0 to FC2; \overline{BG}	37	$V_{CC} = 4.5V$ $I_{OL} = 3.2\text{ mA}$	25°C		0.5	V
					max			
					min			
3	$V_{OL}^{(2)}$	Low level output voltage for: \overline{HALT}	37	$V_{CC} = 4.5V$ $I_{OL} = 1.6\text{ mA}$	25°C		0.5	V
					max			
					min			
4	$V_{OL}^{(3)}$	Low level output voltage for: \overline{AS} ; R/\overline{W} : D0 to D15 UDS; \overline{LDS} ; \overline{VMA} and E	37	$V_{CC} = 4.5V$ $I_{OL} = 5.3\text{ mA}$	25°C		0.5	V
					max			
					min			
5	$V_{OL}^{(4)}$	Low level output voltage for: \overline{RESET}	37	$V_{CC} = 4.5V$ $I_{OL} = 5.0\text{ mA}$	25°C		0.5	V
					max			
					min			
6	V_{OH}	High level output voltage for all outputs	37	$V_{CC} = 4.5V$ $I_{OH} = -400\text{ }\mu A$	25°C	2.4	$V_{CC} - 0.75$	V
					max			
					min			
7	$I_{IH}^{(1)}$	High level input current for all inputs excepted \overline{HALT} and \overline{RESET}	38	$V_{CC} = 5.5V$ $V_I = 5.5V$	25°C		2.5	μA
					max			
					min			
8	$I_{IL}^{(1)}$	Low level input current for all inputs excepted \overline{HALT} and \overline{RESET}	38	$V_{CC} = 5.5V$ $V_I = 0V$	25°C	-2.5		μA
					max			
					min			
9	$I_{IH}^{(2)}$	High level input current for: \overline{HALT} and \overline{RESET}	38	$V_{CC} = 5.5V$ $V_I = 5.5V$	25°C		20	μA
					max			
					min			
10	$I_{IL}^{(2)}$	Low level input current for: \overline{HALT} and \overline{RESET}	38	$V_{CC} = 5.5V$ $V_I = 0V$	25°C	-20		μA
					max			
					min			

Table 2-4. Static Characteristics (Continued)
 $V_{CC} = 5.0V$ $V_{DC} \pm 10\%$; $GND = 0 V_{DC}$; $T_c = -55/+125^\circ C$ and $-40^\circ C/+85^\circ C$

Test Number	Symbol	Parameter	Ref Number (**)	Test Conditions	Test Temperature	Limits		Unit
						Min (*)	Max (*)	
11	I_{OHZ}	High level output 3-state leakage current		$V_{CC} = 5.5V$ $V_{OH} = 2.4V$	25°C	20		μA
					max			
					min			
12	I_{OLZ}	Low level output 3-state leakage current		$V_{CC} = 5.5V$ $V_{OL} = 0.4V$	25°C	20		μA
					max			
					min			
13	V_{IH}	High level input voltage for all inputs		$V_{CC} = 4.5V$ $V_{CC} = 5.5V$	25°C	2.0		V
					max			
					min			
14	V_{IL}	Low level input voltage for all inputs		$V_{CC} = 4.5V$ $V_{CC} = 5.5V$	25°C	0.8		V
					max			
					min			
14A	C_{IN}	Input capacitance (all inputs)	11	Reverse voltage = 0V $f = 1.0$ MHz	25°C	25		μF
					max			
					min			
14B	C_{OUT}	Output capacitance (all inputs)	11	Reverse voltage = 0V $f = 1.0$ MHz	25°C	20		μF
					max			
					min			
14C	V_{TEST}	Internal protection Transient energy rating		See note ⁽⁹⁾ 5 cycles	25°C	-500	+500	V

Note: * Algebraic values

** Measurement method: see "General Requirements" on page 14 and "Test Conditions Specific to the Device" on page 26.

Referred notes are given on page 25.

Table 2-5. Dynamic Characteristics – TS68C000-8
 $V_{CC} = 5.0 V_{DC} \pm 10\%$; $GND = 0 V_{DC}$; $T_c = -55/+125^\circ C$ and $T_c = -40^\circ C/+85^\circ C$

Test Number	Symbol	Parameter	Figure Number (**)	Test Conditions	Test Temperature	Limits		Unit
						Min (*)	Max (*)	
27	t_{SU} (D1CL)	Set-up time Data-in to clock low ⁽¹⁾	10 – 11	See "Input and Output Signals for Dynamic Measurements" on page 29 (a) to (c) $f_C = 8$ MHz	25°C	20 ⁽¹⁰⁾		ns
					max			
					min			

Table 2-5. Dynamic Characteristics – TS68C000-8 (Continued)
 $V_{CC} = 5.0 V_{DC} \pm 10\%$; $GND = 0 V_{DC}$; $T_c = -55/+125^\circ C$ and $T_c = -40^\circ C/+85^\circ C$

Test Number	Symbol	Parameter	Figure Number (**)	Test Conditions	Test Temperature	Limits		Unit
						Min (*)	Max (*)	
47	t_{SU} (SDTCL)	Set-up time \overline{DTACK} low to clock low ⁽¹⁾	10 – 11	Idem test 27	25°C	20 ⁽¹⁰⁾		ns
					max			
					min			
47	t_{SU} (SBRCL)	Set-up time \overline{BR} low to clock low ⁽¹⁾	10 – 11	Idem test 27	25°C	20 ⁽¹⁰⁾		ns
					max			
					min			
47	t_{SU} (SBGCL)	Set-up time \overline{BGACK} low to clock low ⁽¹⁾	10 – 11	Idem test 27	25°C	20 ⁽¹⁰⁾		ns
					max			
					min			
47	t_{SU} (SVPACL)	Set-up time \overline{VPA} low to clock low ⁽¹⁾	10 – 11	Idem test 27	25°C	20 ⁽¹⁰⁾		ns
					max			
					min			
47	t_{SU} (SBERCL)	Set-up time \overline{BERR} low to clock low ⁽¹⁾	10 – 11	Idem test 27	25°C	20 ⁽¹⁰⁾		ns
					max			
					min			
2	t_w (CL)	Clock width low	10 – 11	Idem test 27	25°C	55 ⁽¹⁰⁾	125	ns
					max			
					min			
3	t_w (CH)	Clock width high	10 – 11	Idem test 27	25°C	55	125	ns
					max			
					min			
6A	t_{PLH} t_{PHL} (CHFCV)	Propagation time clock high to FC valid	10 – 11	Idem test 27 Load: 3	25°C		70	ns
					max			
					min			
9	t_{PHL} (CHSLX)	Propagation time clock high to \overline{AS} low	10 – 11	Idem test 27 Load: 4	25°C		60 ⁽³⁾	
					max			
					min			
9	t_{PHL} (CHSL)	Propagation time CLK high to \overline{LDS} , \overline{UDS} low	10 – 11	Idem test 27 Load: 4	25°C		60 ⁽³⁾	ns
					max			
					min			
12	t_{PLH} (CLSH)	Propagation time CLK low to \overline{AS} high	10 – 11	Idem test 27 Load: 4	25°C		70 ⁽³⁾	ns
					max			
					min			

Table 2-5. Dynamic Characteristics – TS68C000-8 (Continued)
 $V_{CC} = 5.0 V_{DC} \pm 10\%$; $GND = 0 V_{DC}$; $T_c = -55/+125^\circ C$ and $T_c = -40^\circ C/+85^\circ C$

Test Number	Symbol	Parameter	Figure Number (**)	Test Conditions	Test Temperature	Limits		Unit
						Min (*)	Max (*)	
12	t_{PLH} (CLSH)	Propagation time CLK low to \overline{LDS} , \overline{UDS} high	10 – 11	Idem test 27 Load: 4	25°C		70 ⁽³⁾	ns
					max			
					min			
18	t_{PLH} (CHRHX)	Propagation time CLK high to R/\overline{W} high	10 – 11	Idem test 27 Load: 4	25°C		70 ⁽³⁾	ns
					max			
					min			
20	t_{PHL} (CHRL)	Propagation time CLK high to R/\overline{W} low	10 – 11	Idem test 27 Load: 4	25°C		70 ⁽³⁾	ns
					max			
					min			
23	t_{PZL} t_{PZH} (CLDO)	Propagation time CLK low to Data-out valid	10 – 11	Idem test 27 Load: 4	25°C		70 ⁽³⁾	ns
					max			
					min			
6	t_{PZL} t_{PZH} (CLAV)	Propagation time CLK low to Address valid	10 – 11	Idem test 27 Load: 3	25°C		70	ns
					max			
					min			
32	t_{HRRF}	$\overline{RESET}/\overline{HALT}$ input transition time	10 – 11	Idem test 27	25°C		200	ns
					max			
					min			
33	t_{PHL} (CHGL)	Propagation time CLK high to \overline{BG} low	12	Idem test 27 Load: 3	25°C		70	ns
					max			
					min			
34	t_{PLH} (CHGH)	Propagation time CLK high to \overline{BG} high	12	Idem test 27 Load: 3	25°C		70	ns
					max			
					min			
40	t_{PHL} (CLVM)	Propagation time CLK low to \overline{VMA} low	13	Idem test 27 Load: 4	25°C		70	ns
					max			
					min			
41	t_{PHL} (CLE)	Propagation time CLK low to E low	13	Idem test 27 Load: 4	25°C		70	ns
					max			
					min			
8	t_h (SHAZ)	Hold time CLK high to Address	10 – 11	Idem test 27 Load: 3	25°C	0		ns
					max			
					min			

Table 2-5. Dynamic Characteristics – TS68C000-8 (Continued)
 $V_{CC} = 5.0 V_{DC} \pm 10\%$; $GND = 0 V_{DC}$; $T_c = -55/+125^\circ C$ and $T_c = -40^\circ C/+85^\circ C$

Test Number	Symbol	Parameter	Figure Number (**)	Test Conditions	Test Temperature	Limits		Unit
						Min (*)	Max (*)	
11	t_{SU} (AVSL)	Set-up time Address valid to AS, LDS, UDS low	10 – 11	Idem test 27 Load: 4	25°C	30 ⁽⁴⁾		ns
					max			
					min			
35	t_{PHL} (BRLGL)	Propagation time \overline{BR} low to \overline{BG} low	12	Idem test 27 Load: 3	25°C	1.5	3.5	CLKS (2)
					max			ns
					min		+90	
37	t_{PLH} (GALEH)	Propagation time \overline{BGACK} low to \overline{BG} high	12	Idem test 27 Load: 3	25°C	1.5	3.5	CLKS (2)
					max			ns
					min		+90	
48	t_{SU} (BELDAL)	Set-up time \overline{BERR} low to \overline{DTACK} low	11	Idem test 27	25°C	20 ⁽⁵⁾	–	ns
					max			
					min			
48	t_{SU} (BELDAL)	Set-up time \overline{BERR} low to \overline{DTACK} low	10 – 11	Idem test 27	25°C	20 ⁽⁵⁾	–	ns
					max			
					min			
26	t_h (DOSL)	Hold time Data-out valid to \overline{LDS} , \overline{UDS} low	11	Idem test 27 Load: 4	25°C	30 ⁽⁴⁾	–	ns
					max			
					min			

Note: * Algebraic values

** Measurement method: see "General Requirements" on page 14 and "Test Conditions Specific to the Device" on page 26

Referred notes are given on page 25.

Table 2-6. Dynamic Characteristics – TS68C000-10

Test Number	Symbol	Parameter	Figure Number (**)	Test Conditions	Test Temperature	Limits		Unit
						Min (*)	Max (*)	
27	t_{SU} (DIDL)	Set-up time Data-in to clock low ⁽¹⁾	10 – 11	See "Input and Output Signals for Dynamic Measurements" on page 29 (a) to (c) $f_c = 10$ MHz	25°C	20 ⁽¹⁰⁾		ns
					max			
					min			
47	t_{SU} (SDTCL)	Set-up time \overline{DTACK} low to clock low ⁽¹⁾	10 – 11	Idem test 27	25°C	20 ⁽¹⁰⁾		ns
					max			
					min			

Table 2-6. Dynamic Characteristics – TS68C000-10 (Continued)

Test Number	Symbol	Parameter	Figure Number (**)	Test Conditions	Test Temperature	Limits		Unit
						Min (*)	Max (*)	
47	t_{SU} (SBRCL)	Set-up time \overline{BR} low to clock low ⁽¹⁾	10 – 11	Idem test 27	25°C	20 ⁽¹⁰⁾		ns
					max			
					min			
47	t_{SU} (SBGCL)	Set-up time \overline{BGACK} low to clock low ⁽¹⁾	10 – 11	Idem test 27	25°C	20 ⁽¹⁰⁾		ns
					max			
					min			
47	t_{SU} (SVPACL)	Set-up time $\overline{VP\overline{A}}$ low to clock low ⁽¹⁾	10 – 11	Idem test 27	25°C	20 ⁽¹⁰⁾		ns
					max			
					min			
47	t_{SU} (SBERCL)	Set-up time \overline{BERR} low to clock low ⁽¹⁾	10 – 11	Idem test 27	25°C	20 ⁽¹⁰⁾		ns
					max			
					min			
2	t_w (CL)	Clock width low	10 – 11	Idem test 27	25°C	45	125	ns
					max			
					min			
3	t_w (CH)	Clock width high	10 – 11	Idem test 27	25°C	45	125	ns
					max			
					min			
6A	t_{PLH} t_{PHL} (CHFCV)	Propagation time clock high to FC valid	10 – 11	Idem test 27 Load: 3	25°C		60	ns
					max			
					min			
9	t_{PHL} (CHSLX)	Propagation time clock high to AS low	10 – 11	Idem test 27 Load: 4	25°C		55 ⁽³⁾	ns
					max			
					min			
9	t_{PHL} (CHSL)	Propagation time CLK high to LDS, UDS low	10 – 11	Idem test 27 Load: 4	25°C		55 ⁽³⁾	ns
					max			
					min			
12	t_{PLH} (CLSH)	Propagation time CLK low to AS high	10 – 11	Idem test 27 Load: 4	25°C		55 ⁽³⁾	ns
					max			
					min			
12	t_{PLH} (CLSH)	Propagation time CLK low to LDS, UDS high	10 – 11	Idem test 27 Load: 4	25°C		55 ⁽³⁾	ns
					max			
					min			

Table 2-6. Dynamic Characteristics – TS68C000-10 (Continued)

Test Number	Symbol	Parameter	Figure Number (**)	Test Conditions	Test Temperature	Limits		Unit
						Min (*)	Max (*)	
18	t_{PLH} (CHRHX)	Propagation time CLK high to R/W high	10 – 11	Idem test 27 Load: 4	25°C		60 ⁽³⁾	ns
					max			
					min			
20	t_{PHL} (CHRL)	Propagation time CLK high to R/W low	10 – 11	Idem test 27 Load: 4	25°C		60 ⁽³⁾	ns
					max			
					min			
23	t_{PZL} t_{PZH} (CLDO)	Propagation time CLK low to Data-out valid	10 – 11	Idem test 27 Load: 4	25°C		55 ⁽³⁾	ns
					max			
					min			
6	t_{PZL} t_{PZH} (CLAV)	Propagation time CLK low to Address valid	10 – 11	Idem test 27 Load: 4	25°C		60	ns
					max			
					min			
32	t_{HRRF} (CHGL)	RESET/HALT input transition time	10 – 11	Idem test 27	25°C		200	ns
					max			
					min			
33	t_{PHL} (CHGL)	Propagation time CLK high to BG low	12	Idem test 27 Load: 3	25°C		60	ns
					max			
					min			
34	t_{PLH} (CHGH)	Propagation time CLK high to BG high	12	Idem test 27 Load: 3	25°C		60	ns
					max			
					min			
40	t_{PHL} (CLVM)	Propagation time CLK low to VMA low	13	Idem test 27 Load: 4	25°C		70	ns
					max			
					min			
41	t_{PHL} (CLE)	Propagation time CLK low to E low	13	Idem test 27 Load: 4	25°C		55	ns
					max			
					min			
8	t_H (SHAZ)	Hold time CLK high to Address	10 – 11	Idem test 27 Load: 3	25°C	0		ns
					max			
					min			
11	t_{SU} (AVSL)	Set-up time Address valid to AS, LDS, UDS low	10 – 11	Idem test 27 Load: 4	25°C	20 ⁽⁴⁾		ns
					max			
					min			



Table 2-6. Dynamic Characteristics – TS68C000-10 (Continued)

Test Number	Symbol	Parameter	Figure Number (**)	Test Conditions	Test Temperature	Limits		Unit
						Min (*)	Max (*)	
35	t_{PHL} (BRLGL)	Propagation time BR low to BG low	12	Idem test 27 Load: 3	25°C	1.5	3.5	CLKS (2)
					max			
					min		+80	ns
37	t_{PLH} (GALGH)	Propagation time BGACK low to BG high	12	Idem test 27 Load: 3	25°C	1.5	3.5	CLKS (2)
					max			
					min		+80	ns
48	t_{SU} (BELDAL)	Set-up time BERR low to DTACK low	11	Idem test 27	25°C	20 ⁽⁵⁾		ns
					max			
					min			
48	t_{SU} (BELDAL)	Set-up time BERR low to DTACK low	10 – 11	Idem test 27	25°C	20 ⁽⁵⁾		ns
					max			
					min			
26	t_H (DOSL)	Hold time Data-out valid to LDS, UDS low	11	Idem test 27 Load: 4	25°C	20 ⁽⁴⁾		ns
					max			
					min			

Note: * Algebraic values

** Measurement method: see "General Requirements" on page 14 and "Test Conditions Specific to the Device" on page 26

Referred notes are given on page 25.

Table 2-7. Dynamic Characteristics – TS68C000-12

Test Number	Symbol	Parameter	Figure Number (**)	Test Conditions	Test Temperature	Limits		Unit
						Min (*)	Max (*)	
27	t_{SU} (DIDL)	Set-up time Data-in to clock low ⁽¹⁾	10 – 11	See "Input and Output Signals for Dynamic Measurements" on page 29 (a) to (c) $f_C = 12$ MHz	25°C	10 ⁽¹⁰⁾		ns
					max			
					min			
47	t_{SU} (SDTCL)	Set-up time DTACK low to clock low ⁽¹⁾	10 – 11	Idem test 27	25°C	20 ⁽¹⁰⁾		ns
					max			
					min			
47	t_{SU} (SBRCL)	Set-up time BR low to clock low ⁽¹⁾	10 – 11	Idem test 27	25°C	20 ⁽¹⁰⁾		ns
					max			
					min			

Table 2-7. Dynamic Characteristics – TS68C000-12 (Continued)

Test Number	Symbol	Parameter	Figure Number (**)	Test Conditions	Test Temperature	Limits		Unit
						Min (*)	Max (*)	
47	t_{SU} (SBGCL)	Set-up time \overline{BGACK} low to clock low ⁽¹⁾	10 – 11	Idem test 27	25°C	20 ⁽¹⁰⁾		ns
					max			
					min			
47	t_{SU} (SVPACL)	Set-up time \overline{VPA} low to clock low ⁽¹⁾	10 – 11	Idem test 27	25°C	20 ⁽¹⁰⁾		ns
					max			
					min			
47	t_{SU} (SBERCL)	Set-up time \overline{BERR} low to clock low ⁽¹⁾	10 – 11	Idem test 27	25°C	20 ⁽¹⁰⁾		ns
					max			
					min			
2	t_w (CL)	Clock width low	10 – 11	Idem test 27	25°C	35	125	ns
					max			
					min			
3	t_w (CH)	Clock width high	10 – 11	Idem test 27	25°C	35	125	ns
					max			
					min			
6A	t_{PLH} t_{PHL} (CHFCV)	Propagation time clock high to FC valid	10 – 11	Idem test 27 Load: 3	25°C		55	ns
					max			
					min			
9	t_{PHL} (CHSLX)	Propagation time clock high to \overline{AS} low	10 – 11	Idem test 27 Load: 4	25°C		55 ⁽³⁾	ns
					max			
					min			
9	t_{PHL} (CHSL)	Propagation time CLK high to \overline{LDS} , \overline{UDS} low	10 – 11	Idem test 27 Load: 4	25°C		55 ⁽³⁾	ns
					max			
					min			
12	t_{PLH} (CLSH)	Propagation time CLK low to \overline{LDS} , \overline{UDS} high	10 – 11	Idem test 27 Load: 4	25°C		50 ⁽³⁾	ns
					max			
					min			
12	t_{PLH} (CLSH)	Propagation time CLK low to \overline{LDS} , \overline{UDS} high	10 – 11	Idem test 27 Load: 4	25°C		50 ⁽³⁾	ns
					max			
					min			
18	t_{PLH} (CHRHX)	Propagation time CLK high to R/W high	10 – 11	Idem test 27 Load: 4	25°C		60 ⁽³⁾	ns
					max			
					min			

Table 2-7. Dynamic Characteristics – TS68C000-12 (Continued)

Test Number	Symbol	Parameter	Figure Number (**)	Test Conditions	Test Temperature	Limits		Unit
						Min (*)	Max (*)	
20	t_{PHL} (CHRL)	Propagation time CLK high to R/W low	11	Idem test 27 Load: 4	25°C		60 ⁽³⁾	ns
					max			
					min			
23	t_{PZL} t_{PZH} (CLDO)	Propagation time CLK low to Data- out valid	11	Idem test 27 Load: 4	25°C		55 ⁽³⁾	ns
					max			
					min			
6	t_{PZL} t_{PZH} (CLAV)	Propagation time CLK low to Address valid	10 – 11	Idem test 27 Load: 4	25°C		55	ns
					max			
					min			
32	t_{HRRF}	$\overline{\text{RESET}}/\overline{\text{HALT}}$ transition time	10 – 11	Idem test 27	25°C		150	ns
					max			
					min			
33	t_{PHL} (CHGL)	Propagation time CLK high to $\overline{\text{BG}}$ low	8 – 9	Idem test 27 Load: 3	25°C		50	ns
					max			
					min			
34	t_{PLH} (CHGH)	Propagation time CLK high to $\overline{\text{BG}}$ high	12	Idem test 27 Load: 3	25°C		50	ns
					max			
					min			
40	t_{PHL} (CLVM)	Propagation time CLK low to $\overline{\text{VMA}}$ low	13	Idem test 27 Load: 4	25°C		70	ns
					max			
					min			
41	t_{PHL} (CLE)	Propagation time CLK low to E low	13	Idem test 27 Load: 4	25°C		45	ns
					max			
					min			
8	t_H (SHAZ)	Hold time CLK high to Address	10 – 11	Idem test 27 Load: 3	25°C	0		ns
					max			
					min			
11	t_{SU} (AVSL)	Set-up time Address valid to $\overline{\text{AS}}$, $\overline{\text{LDS}}$, $\overline{\text{UDS}}$ low	10 – 11	Idem test 27 Load: 4	25°C	15 ⁽⁴⁾		ns
					max			
					min			
35	t_{PHL} (BRLGL)	Propagation time $\overline{\text{BR}}$ low to $\overline{\text{BG}}$ low	12	Idem test 27 Load: 3	25°C	1.5	3.5	CLKS ⁽²⁾
					max			
					min		+70	ns

Table 2-7. Dynamic Characteristics – TS68C000-12 (Continued)

Test Number	Symbol	Parameter	Figure Number (**)	Test Conditions	Test Temperature	Limits		Unit
						Min (*)	Max (*)	
37	t_{PLH} (GALGH)	Propagation time \overline{BGACK} low to \overline{BG} high	12	Idem test 27 Load: 3	25°C	1.5	3.5	CLKS (2)
					max			
					min		+70	ns
48	t_{SU} (BELDAL)	Set-up time \overline{BERR} low to \overline{DTACK} low	11	Idem test 27	25°C	20 ⁽⁵⁾		ns
					max			
					min			
48	t_{SU} (BELDAL)	Set-up time \overline{BERR} low to \overline{DTACK} low	10 – 11	Idem test 27	25°C	20 ⁽⁵⁾		ns
					max			
					min			
26	t_H (DOSL)	Hold time Data-out valid to \overline{LDS} , \overline{UDS} low	11	Idem test 27 Load: 4	25°C	15 ⁽⁴⁾		ns
					max			
					min			

Note: * Algebraic values

** Measurement method: see "General Requirements" on page 14 and "Test Conditions Specific to the Device" on page 26

2.6.1.1 Referred notes to [Table 2-4](#), [Table 2-5](#), [Table 2-6](#), [Table 2-7](#)

The following notes shall apply where referred into [Table 2-4](#), [Table 2-5](#), [Table 2-6](#) and [Table 2-7](#).

- Notes:
- If the asynchronous setup time (47) requirements are satisfied, the \overline{DTACK} low-to-data setup time (31) requirement can be ignored. The data must only satisfy the data-in to clock-low setup time (27) for the following cycle.
 - Where "CLKS" is stated as unit time limit, the relevant time in nanoseconds shall be calculated as the actual cycle time of clock signal input multiply by the given number of CLKS limits.
 - For a loading capacitance of less than or equal to 50 picofarads, substrate 5 nanoseconds from the value given in the maximum columns.
 - Actual value depends on period.
 - If 47 is satisfied for both \overline{DTACK} and \overline{BERR} , 48 may be 0 nanoseconds.
 - The processor will negate \overline{BG} and begin driving the bus again if external arbitration logic negates \overline{BR} before asserting \overline{BGACK} .
 - The falling edge of 56 triggers both the negation of the strobes (\overline{AS} , and X DS) and the falling edge of E. either of these events can occur first depending upon the loading on each signal. Specification 49 indicates the absolute maximum skew that will occur between the rising edge of the strobes and the falling edge of the E clock.
 - When \overline{AS} and R/\overline{W} are equally loaded ($\pm 20\%$), substrate 10 nanoseconds from the values in these columns.
 - Each terminal of the device under test shall be tested separately against all existing VCC and VSS terminals of the device which shall be shorted together for the test. The other untested terminals shall be unconnected during the test. One cycle consists of the application of the bath limits as given in [Table 2-5](#), [Table 2-6](#) and [Table 2-7](#).
 - This value should be treated as a min for design purpose. For the conformance testing the value shall be regarded as the maximum time.

Table 2-8. AC Electrical Specification – Clock Timing

Symbol	Parameter	8 MHz		10 MHz		12.5 MHz		Unit
		Min	Max	Min	Max	Min	Max	
f	Frequency of operation	4.0	8.0	4.0	10.0	4.0	12.5	MHz
t_{cyc}	Cycle time	125	250	100	250	80	250	ns
t_{CL} t_{CH}	Clock pulse width	55	125	45	125	35	125	ns
t_{Cr} t_{Cf}	Rise and fall times		10		10		10	ns

2.6.2 Test Conditions Specific to the Device

2.6.2.1 Loading Network

The applicable loading network shall be as defined in column "Test Conditions" of [Table 2-5](#), [Table 2-6](#) and [Table 2-7](#), referring to the loading network number as shown in [Figure 2-2](#) and [Figure 2-3](#) below.

Figure 2-2. Passive Loads

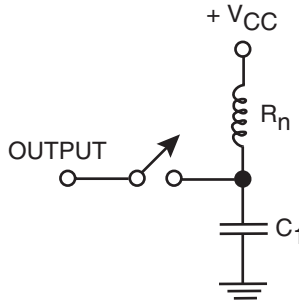
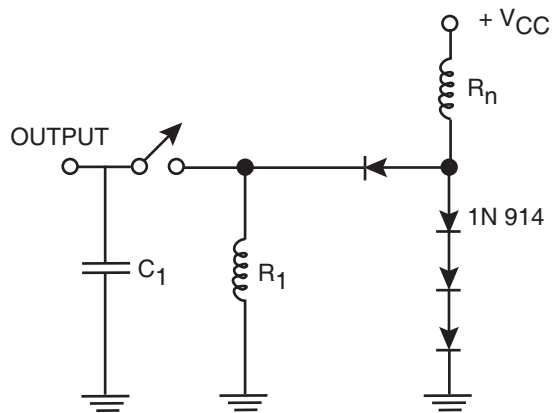

Figure 2-3. Active Loads



Load NBR	Figure	R1	Rn	C ₁ ⁽¹⁾	Output Application
1	5.1	—	910Ω	130 pF	$\overline{\text{RESET}}$
2	5.1	—	2.9 kΩ	70 pF	$\overline{\text{HALT}}$
3	5.2	6.0 k	1.22 kΩ	130 pF	A1 to A23, $\overline{\text{BG}}$ and FC0 to FC2
4	5.2	6.0 k	740Ω	130 pF	All other outputs

Note: 1. C₁ includes all parasitic capacitances of test machines

2.6.2.2 Time Definitions

The times specified in Table 2-5, Table 2-6 and Table 2-7 as dynamic characteristics are defined in Figure 2-4 to Figure 2-7 below by a reference number given in the column "Method" of the tables together with the relevant figure number.

Figure 2-4. Read Cycle Timing

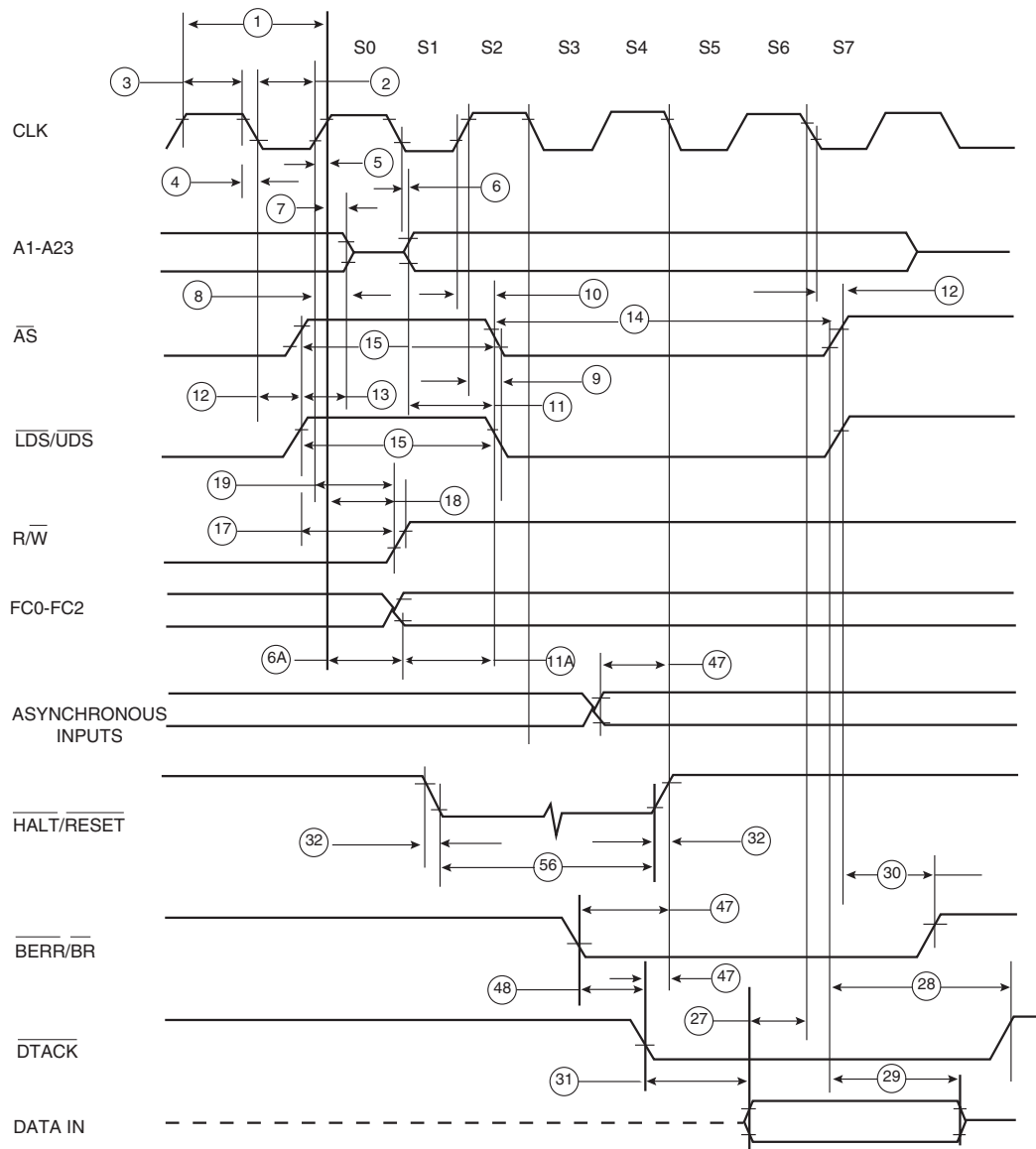

Figure 2-5. Write Cycle Timing

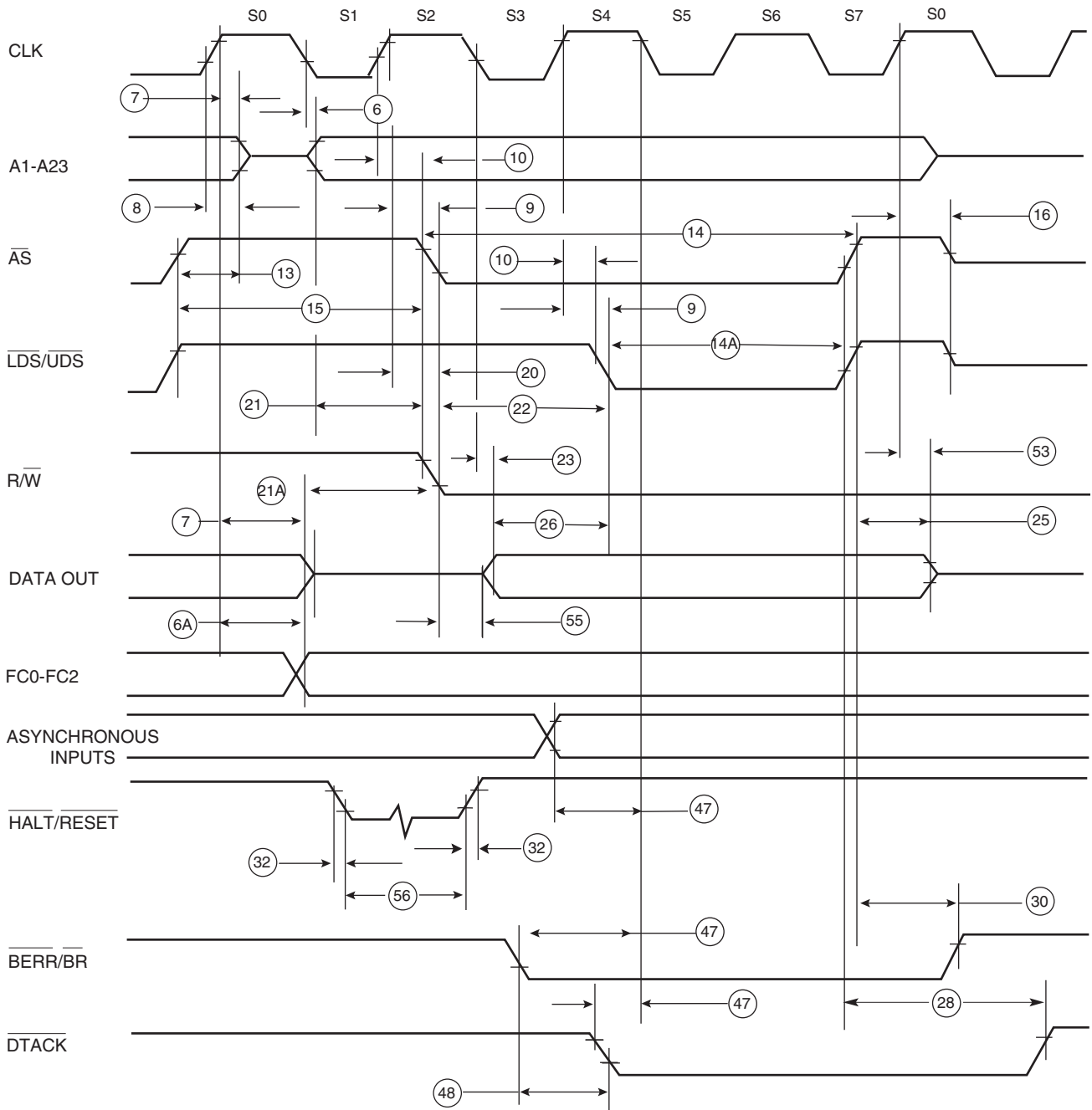

Figure 2-6. AC Electrical Waveforms – Bus Arbitration

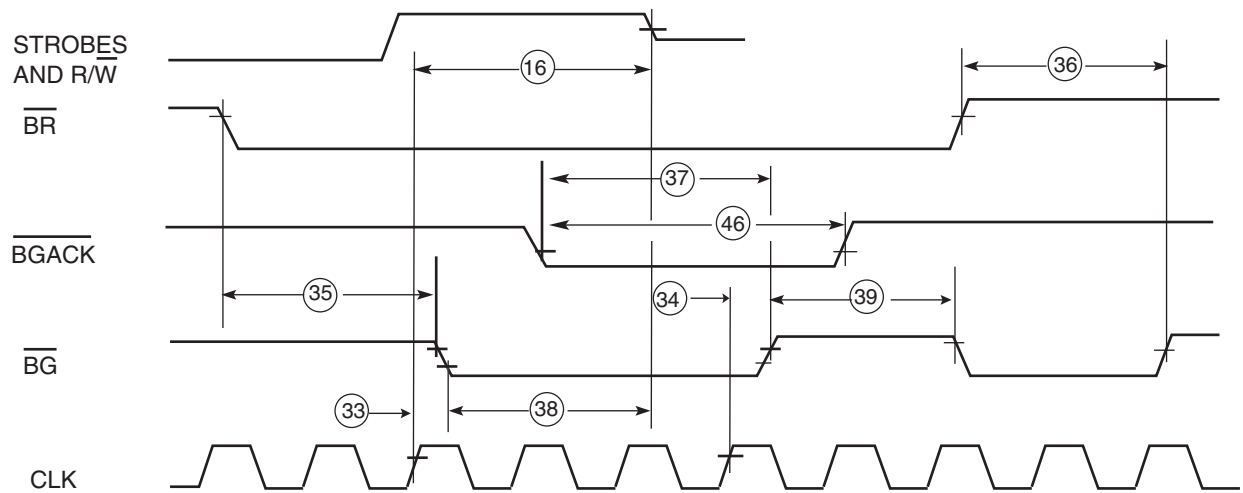
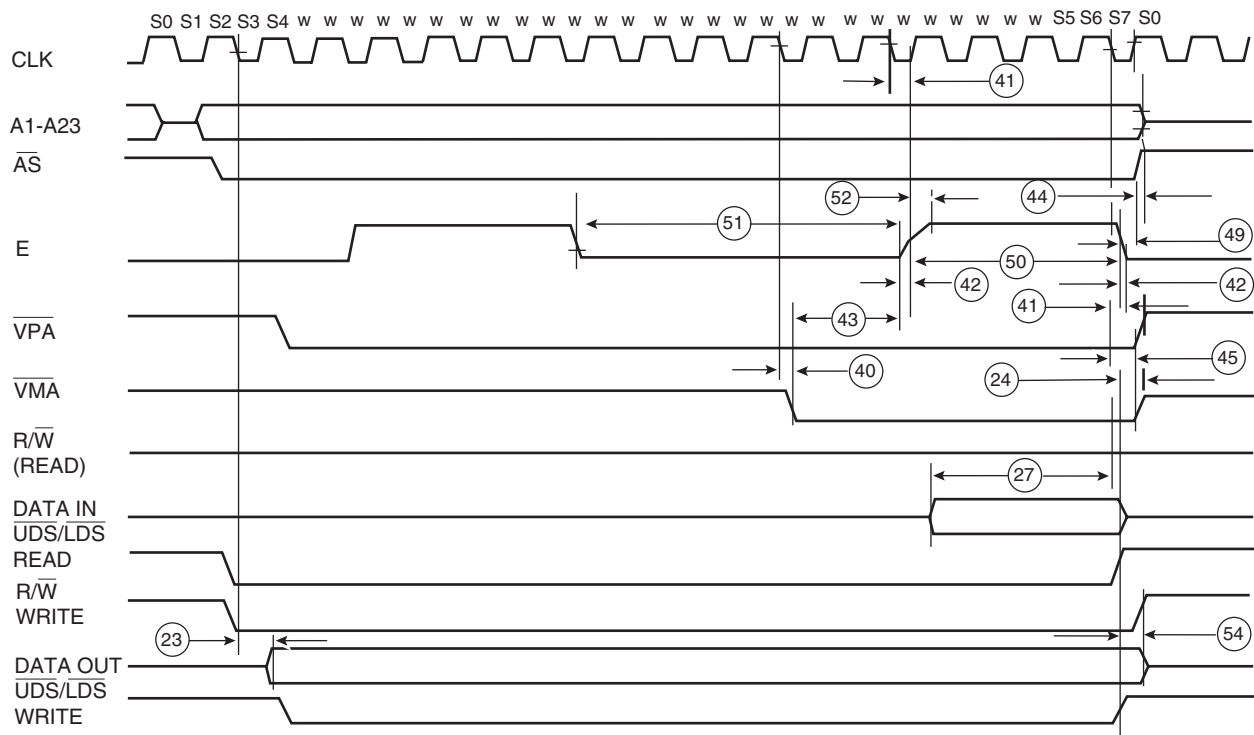

Figure 2-7. Enable/Interface Timing



2.6.2.3 Input and Output Signals for Dynamic Measurements

1. Input pulse characteristics

Where input pulse generator is loaded by only a 50Ω resistor, the input pulse characteristics shall be as shown in Figure 2-8.

Figure 2-8. Input Pulse Characteristics

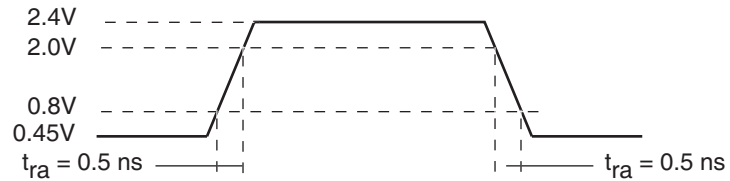

2. Time measurement input voltage references

Input voltages which are taken as reference for time measurement shall be:

$$V_{IL} = 0.8V$$

$$V_{IH} = 2.0V$$

3. Time measurement input voltage references

Where output is (or becomes to) valid state, the output voltages which are taken as reference for time measurements, shall be as shown in [Figure 2-9](#).

Figure 2-9. Output Voltage References

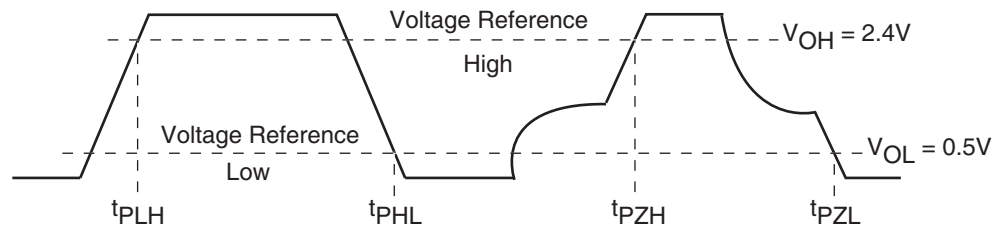

2.6.3 Additional Information

Additional information shall not be for any inspection purposes.

2.6.3.1 Power Considerations

See ["Thermal Characteristics"](#) on page 13.

2.6.3.2 Additional Electrical Characteristics

The following additional characteristics, which are obtained from circuit design, are given for Information only.

Unless otherwise stated, for dynamic additional characteristics, the given reference numbers refer to [Figure 2-1](#) to [Figure 2-7](#) and loading number refer to [Figure 2-2](#) and [Figure 2-3](#) (see ["Test Conditions Specific to the Device"](#) on page 26 of this specification).

The given limits should be valid for all operating temperature ranges as defined in ["Recommended Condition of Use and Guaranteed Characteristics"](#) on page 11 of this specification.

Table 2-9. Additional Electrical Characteristics

Item NO.	Symbol	Parameter	Ref Number	Load Number	TS68C000-8		TS68C000-10		TS68C000-12		Unit
					Limits		Limits		Limits		
					Min	Max	Min	Max	Min	Max	
6A	V_{OH}	High level output voltage for E with pull up $R = 1.1K$ to V_{CC}			Min	$V_{CC} - 0.75$	Min	$V_{CC} - 0.75$	Min	$V_{CC} - 0.75$	V
37	t_{PLZ} t_{PHZ} (CLAZX)	Propagation time CLK low to Address 3-state	Fig. 10 Ref. 7	3		80		70		60	ns
39	t_{PHZ} (CHSZX)	Propagation time CLK high to \overline{AS} , \overline{LDS} , \overline{UDS} 3-state	Fig. 11 Ref. 16	4		80		70		60	ns
40	t_{PLZ} t_{PHZ} (CHRZ)	Propagation time CLK high to R/W 3-state	Fig. 12 Ref. 16	4		80		70		60	ns
41	t_{PHZ} t_{PLZ} (CHAZX)	Propagation time CLK high to Data 3-state	Fig. 11 Ref. 7	4		80		70		60	ns
43	t_H (SHAZ)	Hold time \overline{AS} , \overline{LDS} , \overline{UDS} high to Address	Fig. 10 Ref. 13	3	30		20		10		ns
44	t_w (SL)	\overline{AS}/DS width low	Fig. 10 Ref. 14		240 (4)		195 (4)		160 (4)		ns
45	t_w (SL)	\overline{AS} , \overline{LDS} , \overline{UDS} width high	Fig. 10 Ref. 15		150 (4)		105 (4)		65 (4)		ns
46	t_{SU} (SHRH)	Set-up time \overline{LDS} , \overline{UDS} high to R/W high	Fig. 10 Ref. 17	4	40 (4)		20 (4)		10 (4)		ns
47	t_{SU} (AVRL)	Set-up time Address valid to R/W low	Fig. 10 Ref. 21	4	20 (4)		0 (4)		0 (4)		ns
48	t_{PHL} (RLSL)	Propagation time R/W low to lds, uds low	Fig. 11 Ref. 22	4	80 (4)		50 (4)		30 (4)		ns
49	t_H (SHDO)	Hold time \overline{LDS} , \overline{UDS} high to Data-out	Fig. 11 Ref. 25	4	30 (4)		20 (4)		15 (4)		ns
50	t_H (SHDI)	Hold time \overline{AS} , \overline{LDS} , \overline{UDS} high to Data-in	Fig. 10 Ref. 29		0		0		0		ns
52	t_H (BRHGH)	Propagation time \overline{BR} high to \overline{BG} high ⁽⁶⁾	Fig. 12 Ref. 36	3	1.5	$3.5 + 90$	1.5	$3.5 + 80$	1.5	$3.5 + 70$	CLKS (2) ns



Table 2-9. Additional Electrical Characteristics (Continued)

Item NO.	Symbol	Parameter	Ref Number	Load Number	TS68C000-8		TS68C000-10		TS68C000-12		Unit
					Limits		Limits		Limits		
					Min	Max	Min	Max	Min	Max	
54	t_{PHZ} t_{PLZ} (GLZ)	Propagation time \overline{BG} low to Data and Address 3-state	Fig. 12 Ref. 36	BG, address 3 Data 4		80		70		60	ns
55	t_w (GH)	\overline{BG} width high	Fig. 12 Ref. 39		1.5		1.5		1.5		CLKS ns
56	t_{PLH} (VMLEH)	Propagation time \overline{VMA} low to E high	Fig. 13 Ref. 43	4	200		150		90		ns
57	t_H (SHVPH)	Hold time \overline{AS} , \overline{LDS} , \overline{UDS} high to VPA high	Fig. 20 Ref. 44 (see "Although \overline{UDS} and \overline{LDS} are asserted, no data is read from the bus during the autovector cycle. The vector number is generated internally)." on page 45)	4	0	120	0	90	0	70	ns
58	t_H (ELAI)	Hold time E low to address	Fig. 13 Ref. 45	3	30		10		10		ns
59	t_w (BGL)	\overline{BGACK} width low	Fig. 12 Ref. 46		1.5		1.5		1.5		CLKS (2)
61	t_w (EH)	E width high	Fig. 13 Ref. 50		450		350		280		ns
62	t_w (EL)	E width low	Fig. 13 Ref. 51		700		550		440		ns
63	t_{PHL} (FCVSL)	Propagation time FC valid to \overline{AS} , \overline{DS} low	Fig. 10 Ref. 1A or 11A	4	60 (4)		50 (4)		40 (4)		ns
64	t_{PHL} (SHDAH)	Propagation time \overline{AS} , \overline{DS} high to \overline{DTACK} high	Fig. 10 Ref. 28	4	0	245 ⁽⁴⁾	0	190 ⁽⁴⁾	0	150 ⁽⁴⁾	ns
65	t_{PLH} (SHBEH)	Propagation time \overline{AS} , \overline{DS} high to \overline{BERR} high	Fig. 12 Ref. 30	4	0		0		0		ns
66	t_{SU} (DALDI)	Set-up time \overline{DTACK} low to Data-in ⁽¹⁾	Fig. 10 Ref. 31			90 ⁽⁴⁾		65 ⁽⁴⁾		50 ⁽⁴⁾	ns

Table 2-9. Additional Electrical Characteristics (Continued)

Item NO.	Symbol	Parameter	Ref Number	Load Number	TS68C000-8		TS68C000-10		TS68C000-12		Unit
					Limits		Limits		Limits		
					Min	Max	Min	Max	Min	Max	
67	$t_{THL} t_{TLH}$ (RH)	Transition time \overline{HALT} , \overline{RESET} input	Fig. 10 Ref. 32			200		200		200	ns
69	t_w (HRPW)	\overline{HALT} and \overline{RESET} pulse width after power up	Fig. 10 Ref. 56		10		10		10		CLKS (2)
70	t_{PHL} (ASRV)	Propagation time \overline{AS} low to R/\overline{W} valid	Fig. 11 Ref. 20A	4		20 ⁽⁸⁾		20 ⁽⁸⁾		20 ⁽⁸⁾	ns
71	t_{PHL} (FCVRL)	Propagation time FC valid to R/\overline{W} low	Fig. 11 Ref. 21A	4	60 (4)		50 (4)		30 (4)		ns
73	t_H (CHDOI)	Hold time CLK high to Data-out	Fig. 11 Ref. 53	4	0		0		0		ns
74	$t_{PLH} t_{PHL}$ (RLDBO)	Propagation time R/\overline{W} low to Data-bus impedance change	Fig. 11 Ref. 55	4	30		20		10		ns
75	t_{PHL} (SHEL)	Propagation time \overline{AS} , \overline{DS} low to E low	Fig. 13 Ref. 49	4 ⁽⁷⁾	-70	+70	-55	+55	-45	+45	ns
76	t_H (ELDOI)	Hold time E low to Data-out	Fig. 13 Ref. 54	4	30		20		15		ns

- Notes:
1. If the asynchronous setup time (47) requirements are satisfied, the \overline{DTACK} low-to-data setup time (31) requirement can be ignored. The data must only satisfy the data-in to clock-low setup time (27) for the following cycle.
 2. Where "CLKS" is stated as unit time limit, the relevant time in nanoseconds shall be calculated as the actual cycle time of clock signal input multiply by the given number of CLKS limits.
 3. For a loading capacitance of less than or equal to 50 picofarads, substrate 5 nanoseconds from the value given in the maximum columns.
 4. Actual value depends on period.
 5. If 47 is satisfied for both \overline{DTACK} and \overline{BERR} , 48 may be 0 nanoseconds.
 6. The processor will negate \overline{BG} and begin driving the bus again if external arbitration logic negates \overline{BR} before asserting \overline{BGACK} .
 7. The falling edge of 56 triggers both the negation of the strobes (\overline{AS} , and X DS) and the falling edge of E. either of these events can occur first depending upon the loading on each signal. Specification 49 indicates the absolute maximum skew that will occur between the rising edge of the strobes and the falling edge of the E clock.
 8. When \overline{AS} and R/\overline{W} are equally loaded ($\pm 20\%$), substrate 10 nanoseconds from the values in these columns.
 9. Each terminal of the device under test shall be tested separately against all existing VCC and VSS terminals of the device which shall be shorted together for the test. The other untested terminals shall be unconnected during the test. One cycle consists of the application of the bath limits as given in Table 2-5, Table 2-6 and Table 2-7.
 10. This value should be treated as a min for design purpose. For the conformance testing the value shall be regarded as the maximum time.

2.7 Functional Description

2.7.1 Description of Registers

Figure 2-10. User Programming Model

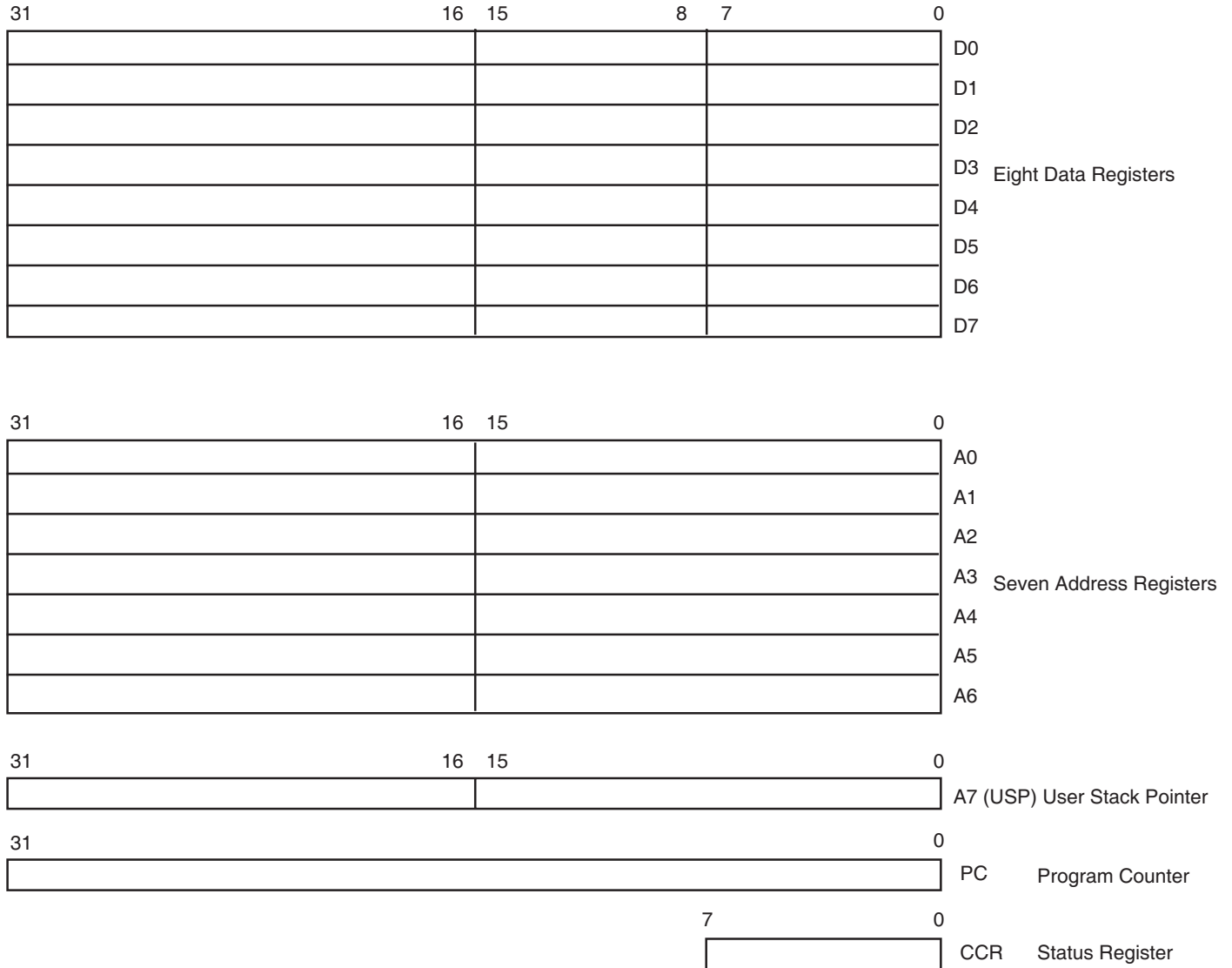

As shown in the user programming model (Figure 2-10), the TS68C000 offers 16/32 bits registers and a 32 bits program counter. The first eight registers (D0 – D7) are used as data registers for byte (8-bit), and long word (32-bit) operations. The second set of seven registers (A0-A6) and the user stack pointer (USP) may be used as software stack pointers and base address registers. In addition, the registers may be used for word and long word operations. All of the 16 registers may be used as index registers.

In supervisor mode, the upper byte of the status register and the supervisor stack pointer (SSP) are also available to the programmer. These registers are shown in Figure 2-11.

Figure 2-11. Supervisor Programming Model Supplement

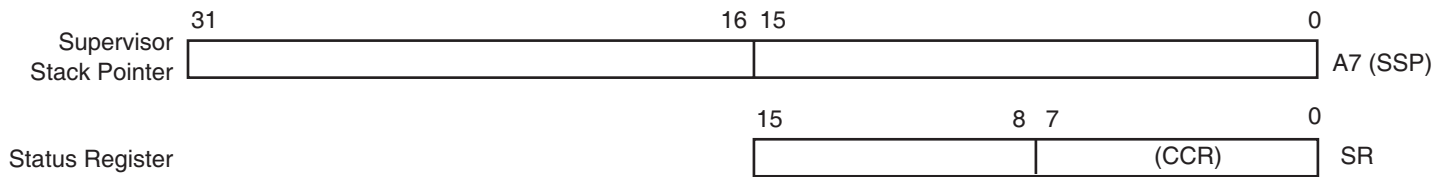

The status register (Figure 2-12) contains the interrupt mask (eight levels available) as well as the conditions codes: extend (X), negative (N), zero (Z), overflow (V), and carry (C). Additional status bits indicate that the processor is in a trace (T) mode and in a supervisor (S) or user state.

Figure 2-12. Status Register

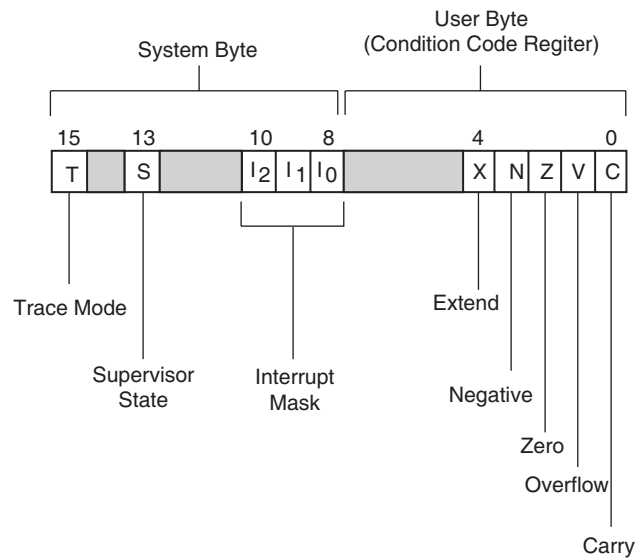

2.7.2 Data Types and Addressing Modes

Five basic data types are supported. These data types are:

- Bits
- BCD Digits (4 bits)
- Bytes (8 bits)
- Words (16 bits)
- Long Words (32 bits)

In addition, operations on other data types such as memory addresses, status ward data, etc. are provided in the instruction set.

The 14 addressing modes, shown in Table 2-10, include six basic types:

- Register Direct
- Register Indirect
- Absolute
- program Counter Relative
- Immediate
- Implied

Included in the register indirect addressing modes is the capability to do post incrementing, pre-decrementing, offsetting, and indexing. The program counter relative mode can also be modified via Indexing and offsetting.

2.7.3 Data Transfer Operations

Transfer of data between devices involves the following leads:

1. address bus A1 through A23,
2. data bus 00 through D15, and
3. control signals.

The address and data buses are separate parallel buses used to transfer data using an asynchronous bus structure. In all cycles, the bus master assumes responsibility for deskewing all signals it issues at both the start and end of a cycle. In addition, the bus master is responsible for deskewing the acknowledge and data signals from the slave device.

The following paragraphs explain the read, write, and read-modify-write cycles. The indivisible read-modify-write cycle is the method used by the TS68C000 for interlocked multiprocessor communications.

2.7.3.1 Read Cycle

During a read cycle, the processor receives data from the memory of a peripheral device. The processor reads bytes of data in all cases. If the instruction specifies a word (or double word) operation, the processor reads both upper and lower bytes simultaneously, by asserting both upper and lower data strobes. When the instruction specifies byte operation, the processor uses an internal AO bit to determine which byte to read and then issues the data strobe required for that byte. For byte operations, when the AO bit equals zero, the upper data strobe is issued. When the AO bit equals one, the lower data strobe is issued. When the data is received, the processor correctly positions it internally.

2.7.3.2 Write Cycle

During a write cycle, the processor sends data to either the memory of a peripheral device. The processor writes bytes of data in all cases. If the instruction specifies a word operation, the processor writes both bytes. When the instruction specifies a byte operation, the processor uses an internal AO bit to determine which byte to write and then issues the data strobe required for that byte. For byte operations, when the AO bit equals zero, the upper data strobe is issued. When the AO bit equals one, the lower data strobe is issued.

Table 2-10. Addressing Modes

Addressing Modes	Syntax
Register direct addressing Data register direct Address register direct	Dn An
Absolute data addressing Absolute short Absolute long	xxx.W xxx.L
Program counter relative addressing Relative with offset Relative with index offset	$d_{16}(PC)$ $d_8(PC, Xn)$

Table 2-10. Addressing Modes (Continued)

Addressing Modes	Syntax
Register Indirect Addressing	
Register Indirect	(An)
Postincrement Register Indirect	(An) +
Predecrement Register Indirect	- (An)
Register Indirect with Offset	$d_{16}(An)$
Indexed Register Indirect with Offset	$d_8(An, Xn)$
Immediate Data Addressing	
Immediate	= XXX
Quick Immediate	= 1- = 8
Implied Addressing	
Implied Register	SR/USP/SP/PC

Notes:

Dn = Data Register

An = Address Register

Xn = Address of Data Register used as Index Register

SR = Status Register

PC = Program Counter

SP = Stack Pointer

USP = User Stack Pointer

() = Effective Address

d_8 = 8-bit Offset (Displacement)

d_{16} = 16-bit Offset (Displacement)

= xxx = Immediate Data

Table 2-11. Instruction Set Summary

Mnemonic	Description
ABCD ADD AND ASL ASR	Add Decimal with Extend Add Logical AND Arithmetic Shift Left Arithmetic Shift Right
Bcc BCHG BCLR BRA BSET BSR BTST	Branch Conditionally Bit Test and Change Bit Test and Clear Branch Always Bit Test and Set Branch to Subroutine Bit Test
CHK CLR CMP	Check Register Against Bounds Clear Operand Compare
DBcc DIVS DIVU	Test Condition, Decrement and Branch Signed Divide Unsigned Divide
EOR EXG EXT	Exclusive OR Exchange Registers Sign Extend
JMP JSR	Jump Jump to Subroutine
LEA LINK LSL LSR	Load Effective Address Link Stack Logical Shift Left Logical Shift Right
MOVE MULS MULU	Move Signed Multiply Unsigned Multiply
NBCD NEG NOP NOT	Negate Decimal with Extend Negate No Operation One's Complement
OR	Logical OR
PEA	Push Effective Address

Table 2-11. Instruction Set Summary (Continued)

Mnemonic	Description
RESET	Rest External Devices
ROL	Rotate Left without Extend
ROR	Rotate Right without Extend
ROXL	Rotate Left with Extend
ROXR	Rotate Right with Extend
RTE	Return from Exception
RTR	Return and Restore
RTS	Return form Subroutine
SBCD	Subtract Decimal with Extend
Scc	Set Conditional
STOP	Stop
SUB	Subtract
SWAP	Swap Data Register Halves
TAS	Test and Set Operand
TRAP	Trap
TRAPV	Trap on Overflow
TST	Test
UNLK	Unlink

2.7.3.3 Read Modify Write Cycle

The read-modify-write cycle performs a read, modifies the data in the arithmetic-logic unit, and writes the data back to the same address. In the TS68C000, this cycle is indivisible in that the address strobe is asserted throughout the entire cycle. The test and set (TAS) instruction uses this cycle to provide meaningful communication between processors in a multiple processor environment. This Instruction is the only instruction that uses the read-modify-write cycles and since the test and set instruction only operates on bytes, all read-modify-write are byte operations.

2.7.4 Instruction Set Overview

The TS68C000 instruction set is shown in [Table 2-11](#). Some additional instructions are variations, or sub-sets, of these and they appear in [Table 2-12](#). Special emphasis has been given to the instruction set's support of structured high-level languages to facilitate ease of programming. Each instruction, with few exceptions, operates on bytes, words, and long words and most instructions can use any of the 14 addressing modes. Combining instruction types, data types, and addressing modes, over 1000 useful instructions are provided. These instructions include signed and unsigned, multiply and divide, "quick" arithmetic operations, BCD arithmetic, and expanded operations (through traps).

Table 2-12. Variations of Instruction Types

Instruction Type	Variation	Description
ADD	ADD ADDA ADDQ ADDI ADDX	Add Add Address Add Quick Add Immediate Add with Extend
AND	AND ANDI ANDI to CCR ANDI to SR	Logical AND And Immediate And Immediate to Condition codes And Immediate to Status Register
CMP	CMP CMPA CMPM CMPI	Compare Compare Address Compare Memory Compare Immediate
EOR	EOR EORI EORI to CCR EORI to SR	Exclusive OR Exclusive OR Immediate Exclusive OR Immediate to condition Codes Exclusive OR Immediate to Status Register
MOVE	MOVE MOVEA MOVEM MOVEP MOVEQ MOVE from SR MOVE to SR MOVE to CCR MOVE USP	Move Move Address Move Multiple Registers Move Peripheral Data Move Quick Move from Status Register Move to Status Register Move to Condition Codes Move User Stack Pointer
NEG	NEG NEGX	Negate Negate with Extend
OR	OR ORI ORI to CCR ORI to SR	Logical OR OR Immediate OR Immediate to Condition Codes OR Immediate to Status Register
SUB	SUB SUBA SUBI SUBQ SUBX	Subtract Subtract Address Subtract Immediate Subtract Quick Subtract Extend

2.7.5 Processing States

The TS68C000 is always in one of three processing states: normal, exception, or halted.

2.7.5.1 Normal Processing

The normal processing state is that associated with instruction execution; the memory references are to fetch instructions and operands, and to store results. A special case of normal state is the stopped state which the processor enters when a stop instruction is executed. In this state, no further references are made.

2.7.5.2 Exception Processing

The exception processing state is associated with interrupts, trap instructions, tracing, and other exception conditions. The exception may be internally generated by an instruction or by an unusual condition arising during the execution of an instruction. Externally, exception processing can be forced by an interrupt, by a bus error, or by a reset. Exception processing is designed to provide an efficient context switch so that the processor may handle unusual conditions.

2.7.5.3 Halted Processing

The halted processing state is an indication of catastrophic hardware failure. For example, if during the exception processing of a bus error another bus error occurs, the processor assumes that the system is unusable and halts. Only an external reset can restart a halted processor. Note that a processor in the stopped state is not in the halted state, nor vice versa.

Asserting the reset and halt line for ten cycles will cause a processor reset, except when VCC is initially applied to the processor. In this case, an external reset must be applied for at least 100 milliseconds.

2.7.6 Interface with EF 6800 Peripherals

Extensive line of EF6800 peripherals are directly compatible with the TS68C000.

Note: It is the own user's responsibility to verify the actual EF 6800 peripheral performances to be compatible to the actual used TS68C000 microprocessor performances.

Some of the EF 6800 peripheral that are particularly useful are:

EF6821: Peripheral Interface Adapter

EF6840: Programmable Timer Module

EF6850: Asynchronous Communications Interface Adapter

EF6852: Synchronous Serial Data Adapter

EF6854: Advanced Data Link Controller

To interface the synchronous EF 6800 peripherals with the asynchronous TS68C000, the processor modifies its bus cycle to meet the EF 6800 cycle requirements whenever an EF 6800 device address is detected. This is possible since both processors use memory mapped I/O. [Figure 2-13](#) is a flowchart of the interface operation between the processor and EF 6800 devices.

Figure 2-13. EF6800 Interfacing Flowchart

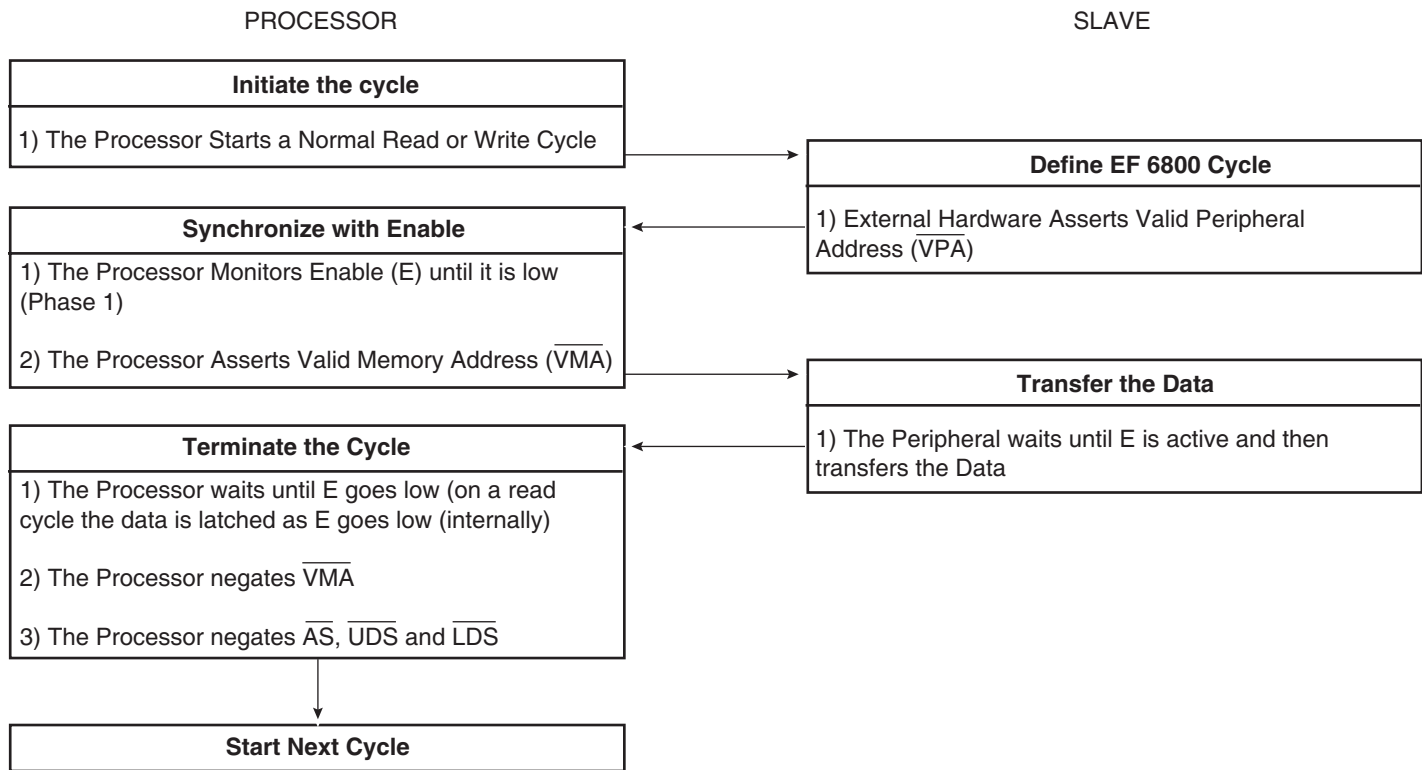

2.7.6.1 Data Transfer Operation

Three signals on processor provide the EF 6800 interface. They are: enable (E), valid memory address (\overline{VMA}), and valid peripheral address (\overline{VPA}). Enable corresponds to the E or phase 2 signal in existing EF 6800 systems. The bus frequency is one tenth of the incoming TS68C000 clock frequency. The timing of E allows 1 MHz peripherals to be used 8 MHz TS68C000. Enable has a 60/40 duty cycle, that is, it is low for six input clocks and high for four input clocks. This duty cycle allows the processor to do successive \overline{VPA} accesses on successive E pulses.

EF6800 cycle timing is given in [Figure 2-17](#) and [Figure 2-18](#). At state zero (50) in the cycle, the address bus is in the high-impedance state. A function code is asserted on the function code output lines. One-half clock later, in state 1, the address bus is released from the high-impedance state.

During state 2, the address strobe (\overline{AS}) is asserted to indicate that there is a valid address on the address bus. If the bus cycle is a read cycle, the upper and/or lower data strobes are also asserted in state 2. If the bus cycle is a write cycle, the read/write ($\overline{R/W}$) signal is switched to low (write) during state 2. One-half clock later, in state 3, the write data is placed on the data bus, and in state 4 the data strobes are issued to indicate valid data on the data bus. The processor now inserts wait states until it recognizes the assertion of \overline{VPA} .

The \overline{VPA} input signals the processor that the address on the bus is the address of an EF 6800 device (or an area reserved for EF6800 devices) and that the bus should conform to the phase 2 transfer characteristics of the EF 6800 bus. Valid peripheral address is derived by decoding the address bus, conditioned by the address strobe. Chip select for the EF 6800 peripherals should be derived by decoding the address bus conditioned by \overline{VMA} .

After recognition of \overline{VPA} , the processor assures that the enable (E) is low, by waiting if necessary, and subsequently asserts \overline{VMA} . Valid memory address is then used as part of the chip select equation of the peripheral. This ensures that the EF6800 peripherals are selected and deselected at the correct time. The peripheral now runs its cycle during the high portion of the signal. Figure 2-17 and Figure 2-18 depict the best and worst case EF6800 cycle timing. This cycle length is dependent strictly upon when \overline{VPA} is asserted in relationship to the E clock.

If it is assumed that external circuitry asserts \overline{VPA} as soon as possible after the assertion of \overline{AS} , then \overline{VPA} will be recognized as being asserted on the falling edge of S4. In this case, no "extra" wait cycles will be inserted prior to the recognition of \overline{VPA} asserted and only the wait cycles inserted to synchronize with the E clock will determine the total length of the cycle. In any case, the synchronization delay will be some integral number of clock cycles within the following two extremes:

1. Best Case – \overline{VPA} is recognized as being asserted on the falling edge three clock cycles before E rises (or three clock cycles after E falls).
2. Worst Case – \overline{VPA} is recognized as being asserted on the falling edge two clock cycles before E rises (or four clock cycles after E falls).

During a read cycle, the processor latches the peripheral data in state 6. For all cycles, the processor negates the address and data strobes one-half clock cycle later in state 7 and the enable signal goes low at this time. Another half clock later, the address bus is put in the high-impedance state. During a write cycle the data bus is put in the high-impedance state and the read/write signal is switched high. The peripheral logic must remove \overline{VPA} within one clock after the address strobe is negated.

\overline{DTACK} should not be asserted while \overline{VPA} is asserted. Notice that the TS68C000 \overline{VMA} is active low, contrasted with the active high EF 6800 \overline{VMA} . This allows the processor to put its buses in the high-impedance state on DMA requests without inadvertently selecting the peripherals.

Figure 2-14. TS68C000 to EF6800 Peripheral Timing – Best Case

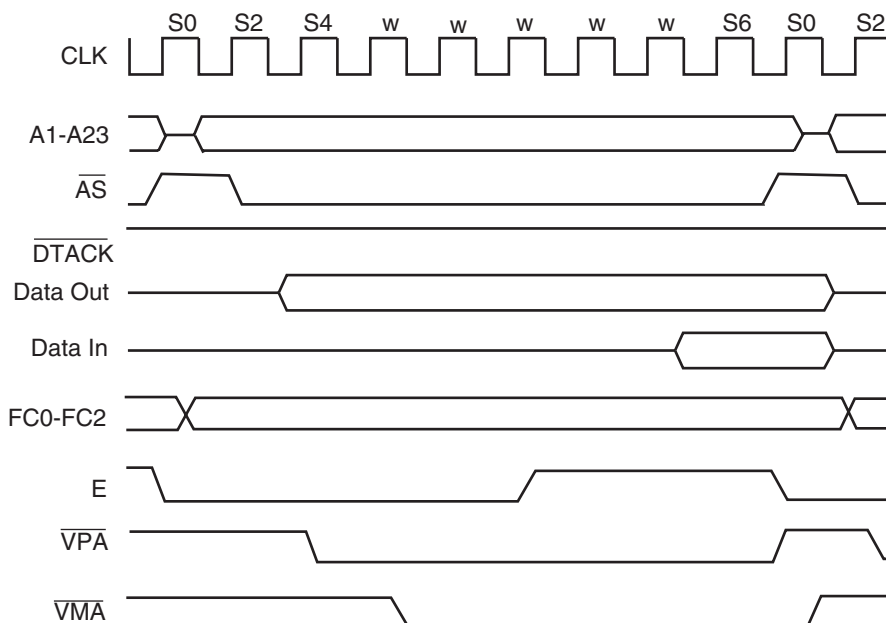
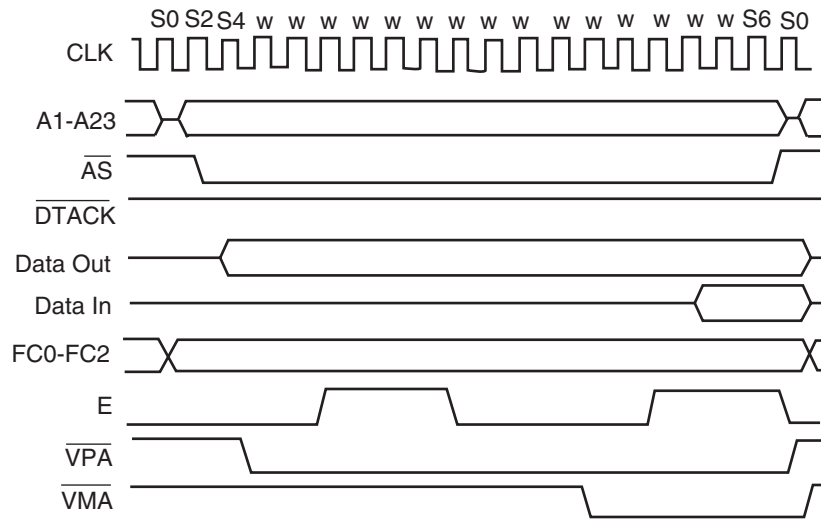

Figure 2-15. TS68C000 to EF6800 Peripheral Timing – Worst Case



2.7.6.2 *Interrupt Interface Operation*

During an interrupt acknowledge cycle while the processor is fetching the vector, the \overline{VPA} is asserted, the TS68C000 will assert \overline{VMA} and complete a normal EF 6800 read cycle as shown in Figure 2-16. The processor will then use an internally generated vector that is a function of the interrupt being serviced. This process is known as autovectoring. The seven autovectors are vector number 25 through 31 (decimal).

Autovectoring operates in the same fashion (but is not restricted to) the EF 6800 interrupt sequence. The basic difference is that there are six normal interrupt vectors and one NMI type vector. As with both the EF 6800 and the TS68C(XX)'s normal vectored interrupt, the Interrupt service routine can be located anywhere in the address space. This is due to the fact that while the vector numbers are fixed the contents of the vector table entries are assigned by the user.

Since \overline{VMA} is asserted during autovectoring. The EF 6800 peripheral address decoding should prevent unintended accesses.

Figure 2-16. Autovector Operation Timing Diagram

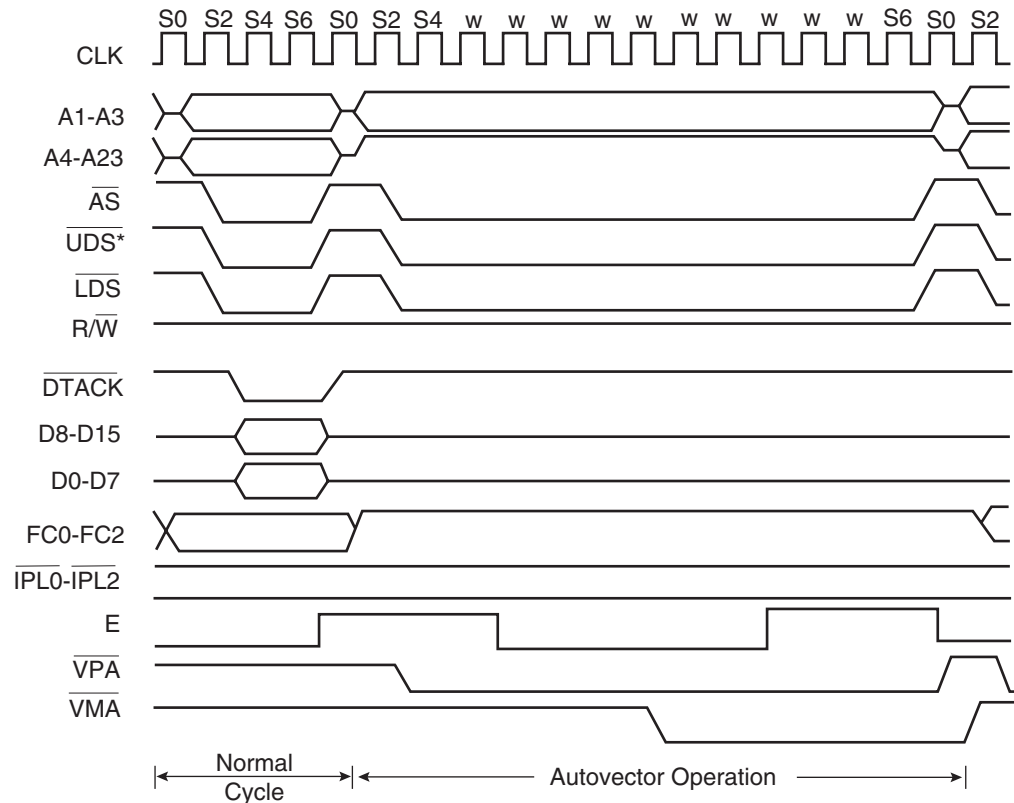

Although \overline{UDS} and \overline{LDS} are asserted, no data is read from the bus during the autovector cycle. The vector number is generated internally).

Table 2-13. Dynamic Electrical Characteristics TS68C000 to EF 6800 Peripheral

Number	Symbol	Parameter	8 MHz		10 MHz		12.5 MHz		Unit
			Limits		Limits		Limits		
			Min	Max	Min	Max	Min	Max	
12	CLSH	Clock low to \overline{AS} , \overline{DS} high ⁽¹⁾		70		55		50	ns
18	CHRH	Clock high to R/\overline{W} high ⁽¹⁾	0	70	0	60	0	60	ns
20	CHRL	Clock high to R/\overline{W} low (write) ⁽¹⁾		70		60		60	ns
23	CLDO	Clock low to data out valid (write)		70		55		55	ns
27	CLDO	Data in to clock low (set up time on read) ⁽²⁾	15		10		10		ns
29	SHDII	\overline{AS} , \overline{DS} high to Data in invalid (hold time on read)	0		0		0		ns
40	CLVML	\overline{AS} , \overline{DS} high to \overline{VPA} high		70		70		70	ns
41	CLET	Clock low to E transition		70		55		45	ns
42	Erf	E output rise and fall time		25		25		25	ns
43	VMLEH	\overline{VMA} low to E high	200		150		90		ns
44	SHVPH	\overline{AS} , \overline{DS} high to \overline{VPA} high	0	120	0	90	0	70	ns

Table 2-13. Dynamic Electrical Characteristics TS68C000 to EF 6800 Peripheral (Continued)

Number	Symbol	Parameter	8 MHz		10 MHz		12.5 MHz		Unit
			Limits		Limits		Limits		
			Min	Max	Min	Max	Min	Max	
45	ELCAI	E low to control, address bus invalid (address hold time)	30		10		10		ns
47	ASI	Asynchronous input setup time ⁽²⁾	20		20		20		ns
49	SHEL	\overline{AS} , \overline{DS} high to E low ⁽³⁾	-70	70	-55	55	-80		ns
50	EH	E width high	450		350		280		ns
51	EL	E width low	700		550		440		ns
54	ELDOI	E low to data out invalid	30		20		15		ns

- Notes:
1. For a loading capacitance of less than or equal to 50 picofarads, subtract 5 nanoseconds from the value given in the maximum columns.
 2. If the asynchronous setup time (47) requirements are satisfied, the \overline{DTACK} low-to-data setup time (31) required can be ignored. The data must only satisfy the date in clock-low setup time (27) for the following cycle.
 3. The falling edge of S6 triggers both the negation of the strobes (\overline{AS} and \overline{XDS}) and the falling edge of E. Either of these events can occur first, depending upon the loading on each signal specification 49 indicates the absolute maximum skew that will occur between the rising edge of the strobes and the falling edge of the E clock.

Figure 2-17. TS68C000 to EF6800 Peripheral Timing Diagram – Best Case

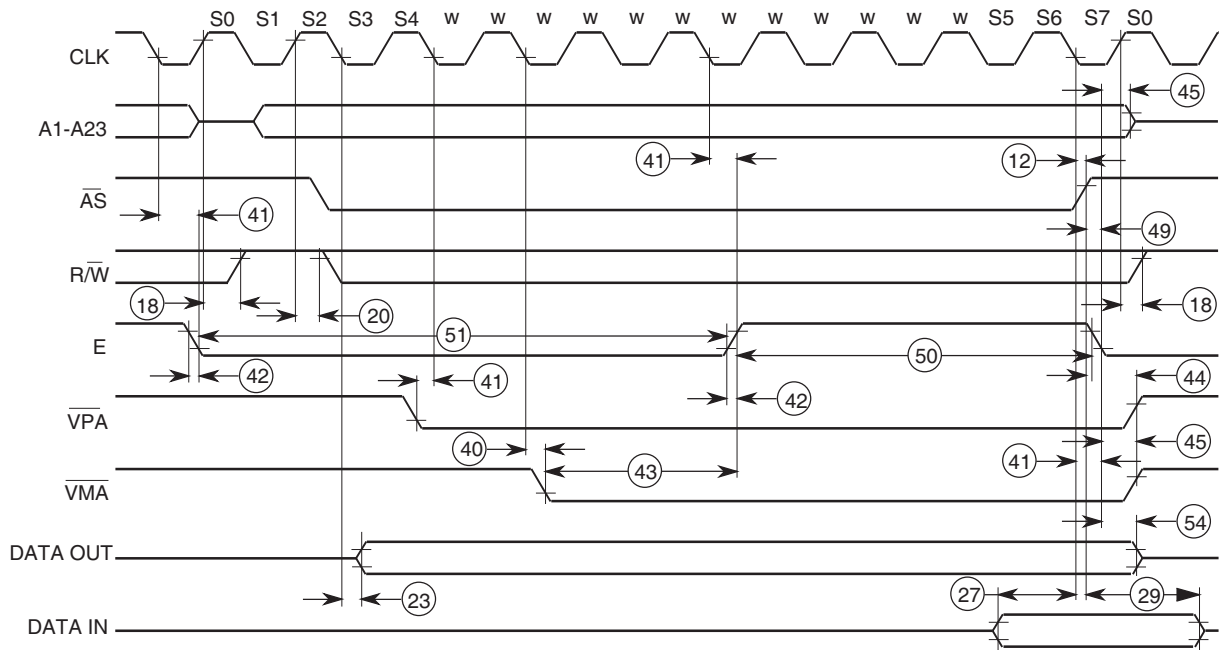

Note: This timing diagram is included for those who wish to design their own circuit to generate \overline{VMA} . It shows the worst case possibly attainable.

Figure 2-18. TS68C000 to EF6800 Peripheral Timing Diagram – Worst Case

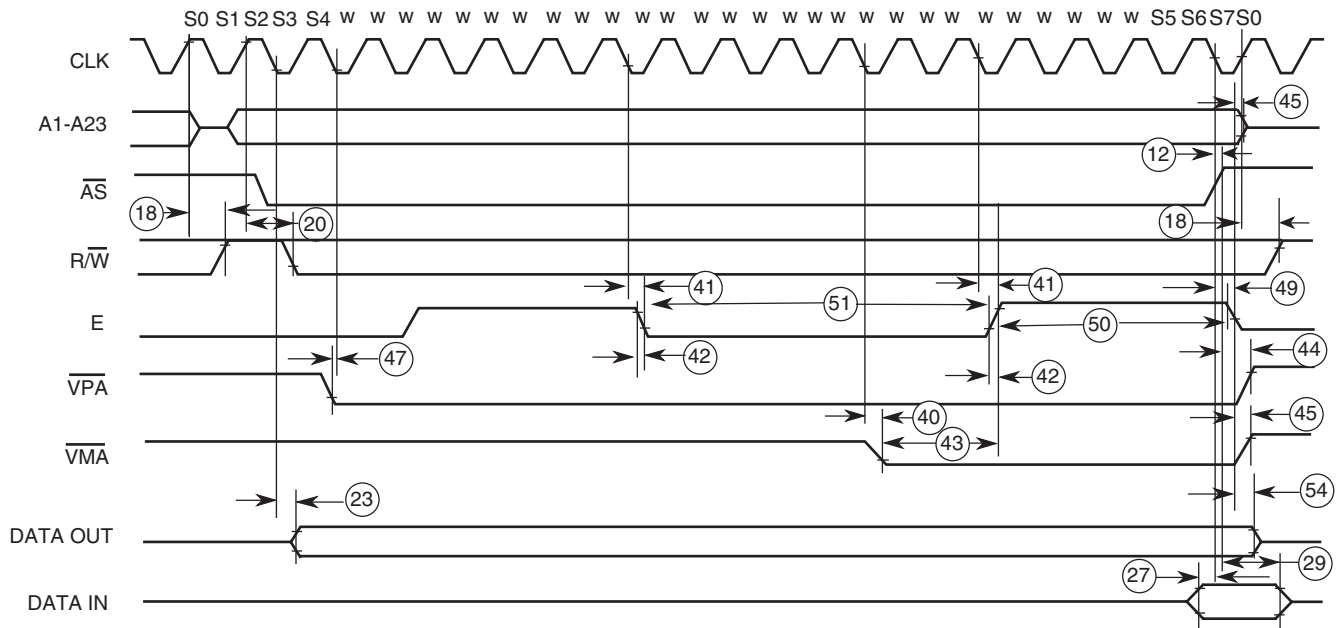

Note: This timing diagram is included for those who wish to design their own circuit to generate \overline{VMA} . It shows the worst case possibly attainable.

2.8 Preparation For Delivery

2.8.1 Packaging

Microcircuits are prepared for delivery in accordance with MIL-PRF-38535.

2.8.2 Certificate of Compliance

Atmel offers a certificate of compliance with each shipment of parts, affirming the products are in compliance with MIL-STD-883 and guaranteeing the parameters not tested at extreme temperatures for the entire temperature range.

2.9 Handling

MOS devices must be handled with certain precautions to avoid damage due to accumulation of static charge. Input protection devices have been designed in the chip to minimize the effect of this static buildup. However, the following handling practices are recommended:

- Device should be handled on benches with conductive and grounded surface.
- Ground test equipment, tools and operator.
- Do not handle devices by the leads.
- Store devices in conductive foam or carriers.
- Avoid use of plastic, rubber, or silk in MOS areas.
- Maintain relative humidity above 50%, if practical.

Figure 2-21. 68-lead – Leadless Ceramic Chip Carrier

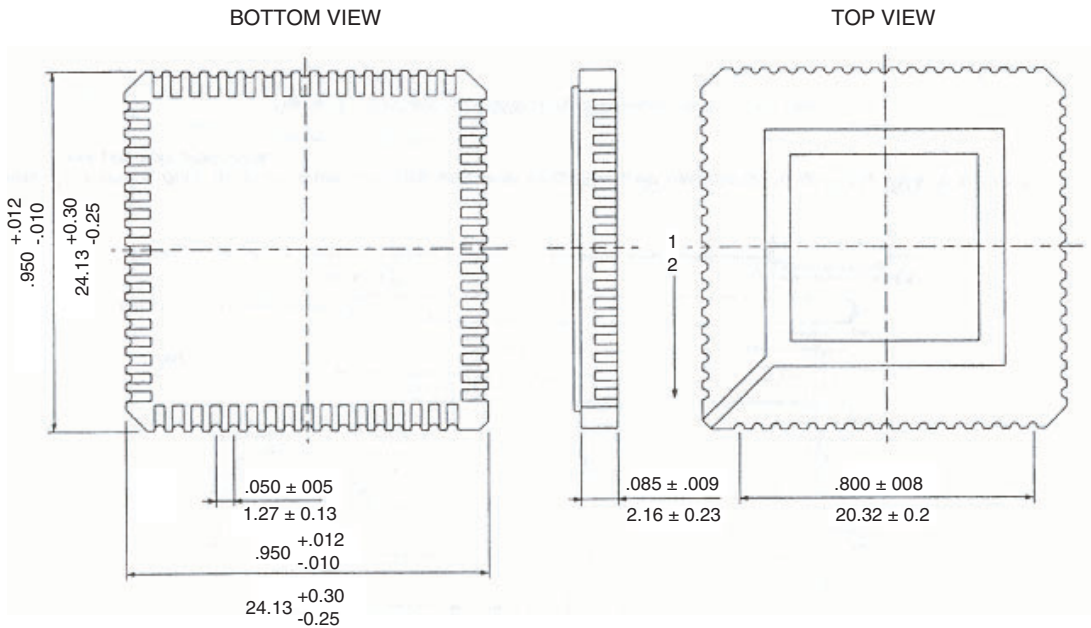
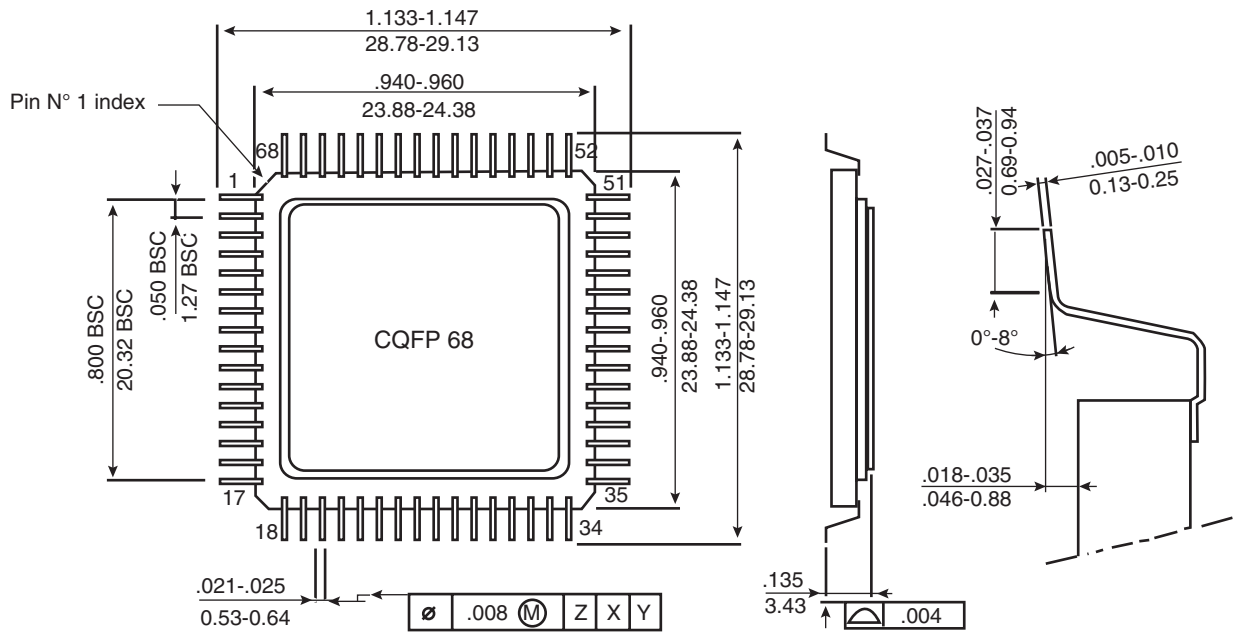
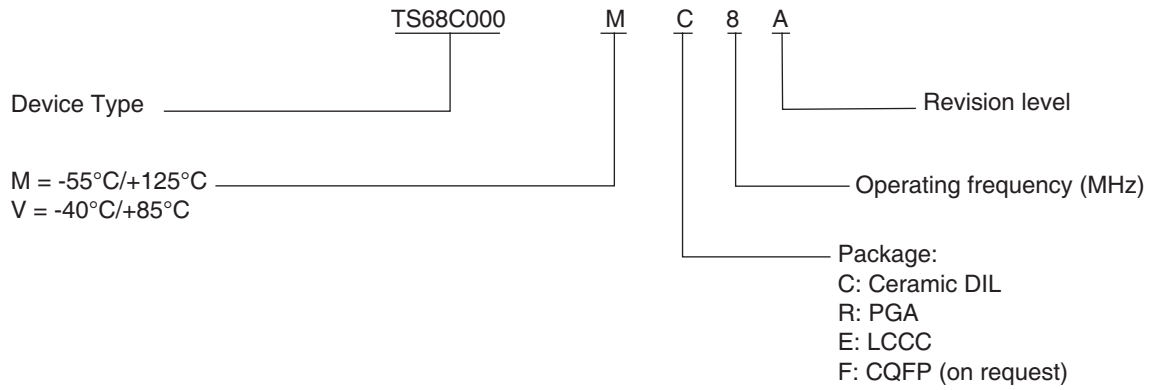

Figure 2-22. 68-lead – Ceramic Quad Flat Pack



2.11.3 Standard Product



Note: 1. For availability of the different versions, contact your Atmel sale office.



Atmel Corporation

2325 Orchard Parkway
San Jose, CA 95131, USA
Tel: 1(408) 441-0311
Fax: 1(408) 487-2600

Regional Headquarters

Europe

Atmel Sarl
Route des Arsenalux 41
Case Postale 80
CH-1705 Fribourg
Switzerland
Tel: (41) 26-426-5555
Fax: (41) 26-426-5500

Asia

Room 1219
Chinachem Golden Plaza
77 Mody Road Tsimshatsui
East Kowloon
Hong Kong
Tel: (852) 2721-9778
Fax: (852) 2722-1369

Japan

9F, Tonetsu Shinkawa Bldg.
1-24-8 Shinkawa
Chuo-ku, Tokyo 104-0033
Japan
Tel: (81) 3-3523-3551
Fax: (81) 3-3523-7581

Atmel Operations

Memory

2325 Orchard Parkway
San Jose, CA 95131, USA
Tel: 1(408) 441-0311
Fax: 1(408) 436-4314

Microcontrollers

2325 Orchard Parkway
San Jose, CA 95131, USA
Tel: 1(408) 441-0311
Fax: 1(408) 436-4314

La Chantrerie
BP 70602
44306 Nantes Cedex 3, France
Tel: (33) 2-40-18-18-18
Fax: (33) 2-40-18-19-60

ASIC/ASSP/Smart Cards

Zone Industrielle
13106 Rousset Cedex, France
Tel: (33) 4-42-53-60-00
Fax: (33) 4-42-53-60-01

1150 East Cheyenne Mtn. Blvd.
Colorado Springs, CO 80906, USA
Tel: 1(719) 576-3300
Fax: 1(719) 540-1759

Scottish Enterprise Technology Park
Maxwell Building
East Kilbride G75 0QR, Scotland
Tel: (44) 1355-803-000
Fax: (44) 1355-242-743

RF/Automotive

Theresienstrasse 2
Postfach 3535
74025 Heilbronn, Germany
Tel: (49) 71-31-67-0
Fax: (49) 71-31-67-2340

1150 East Cheyenne Mtn. Blvd.
Colorado Springs, CO 80906, USA
Tel: 1(719) 576-3300
Fax: 1(719) 540-1759

Biometrics/Imaging/Hi-Rel MPU/ High Speed Converters/RF Datacom

Avenue de Rochepleine
BP 123
38521 Saint-Egreve Cedex, France
Tel: (33) 4-76-58-30-00
Fax: (33) 4-76-58-34-80

Literature Requests

www.atmel.com/literature

Disclaimer: The information in this document is provided in connection with Atmel products. No license, express or implied, by estoppel or otherwise, to any intellectual property right is granted by this document or in connection with the sale of Atmel products. **EXCEPT AS SET FORTH IN ATMEL'S TERMS AND CONDITIONS OF SALE LOCATED ON ATMEL'S WEB SITE, ATMEL ASSUMES NO LIABILITY WHATSOEVER AND DISCLAIMS ANY EXPRESS, IMPLIED OR STATUTORY WARRANTY RELATING TO ITS PRODUCTS INCLUDING, BUT NOT LIMITED TO, THE IMPLIED WARRANTY OF MERCHANTABILITY, FITNESS FOR A PARTICULAR PURPOSE, OR NON-INFRINGEMENT. IN NO EVENT SHALL ATMEL BE LIABLE FOR ANY DIRECT, INDIRECT, CONSEQUENTIAL, PUNITIVE, SPECIAL OR INCIDENTAL DAMAGES (INCLUDING, WITHOUT LIMITATION, DAMAGES FOR LOSS OF PROFITS, BUSINESS INTERRUPTION, OR LOSS OF INFORMATION) ARISING OUT OF THE USE OR INABILITY TO USE THIS DOCUMENT, EVEN IF ATMEL HAS BEEN ADVISED OF THE POSSIBILITY OF SUCH DAMAGES.** Atmel makes no representations or warranties with respect to the accuracy or completeness of the contents of this document and reserves the right to make changes to specifications and product descriptions at any time without notice. Atmel does not make any commitment to update the information contained herein. Unless specifically provided otherwise, Atmel products are not suitable for, and shall not be used in, automotive applications. Atmel's products are not intended, authorized, or warranted for use as components in applications intended to support or sustain life.

© Atmel Corporation 2005. All rights reserved. Atmel®, logo and combinations thereof, Everywhere You Are® and others, are registered trademarks or trademarks of Atmel Corporation or its subsidiaries. Other terms and product names may be trademarks of others.



Printed on recycled paper.

2170A-HIREL-09/05