

## POWER MANAGEMENT

---

### Features

- Supports portable wireless charging applications
- Wireless power systems up to 5W
- Integrated controller and FLASH for communications and control
- High precision data converter
- Low external component count
- Product is lead-free, Halogen Free, RoHS / WEEE compliant

### Applications

- Low-power wireless chargers for:
  - Smart Watches
  - Wearables
  - Toys
  - Portable Lighting
  - Medical Devices

### Description

The TS80002 is a power transmitter communications and control unit for wireless charging applications. The TS80002 can support systems up to 5W and proprietary applications.

The TS80002 performs the necessary coding of protocol to send commands to the transmitter to adjust the power level accordingly.

### Specifications

- RISC-based controller core with flash and SRAM memory
- 10-bit A/D converter
- Two 16-bit timers, advanced control and general purpose
- 8-bit timer
- Auto-wakeup and watchdog timers
- 4 configurable general purpose IOs
- I2C interface
- 20 pin 3x3 QFN

## Typical Application Circuit

---

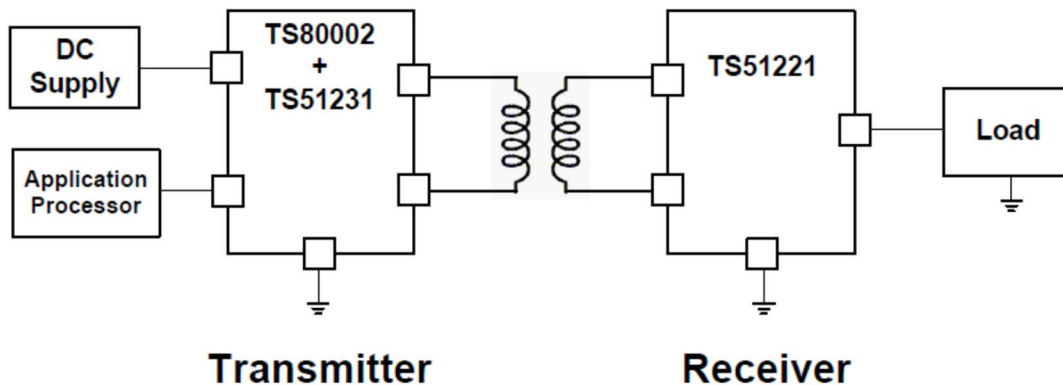

## Pinout (Top View)

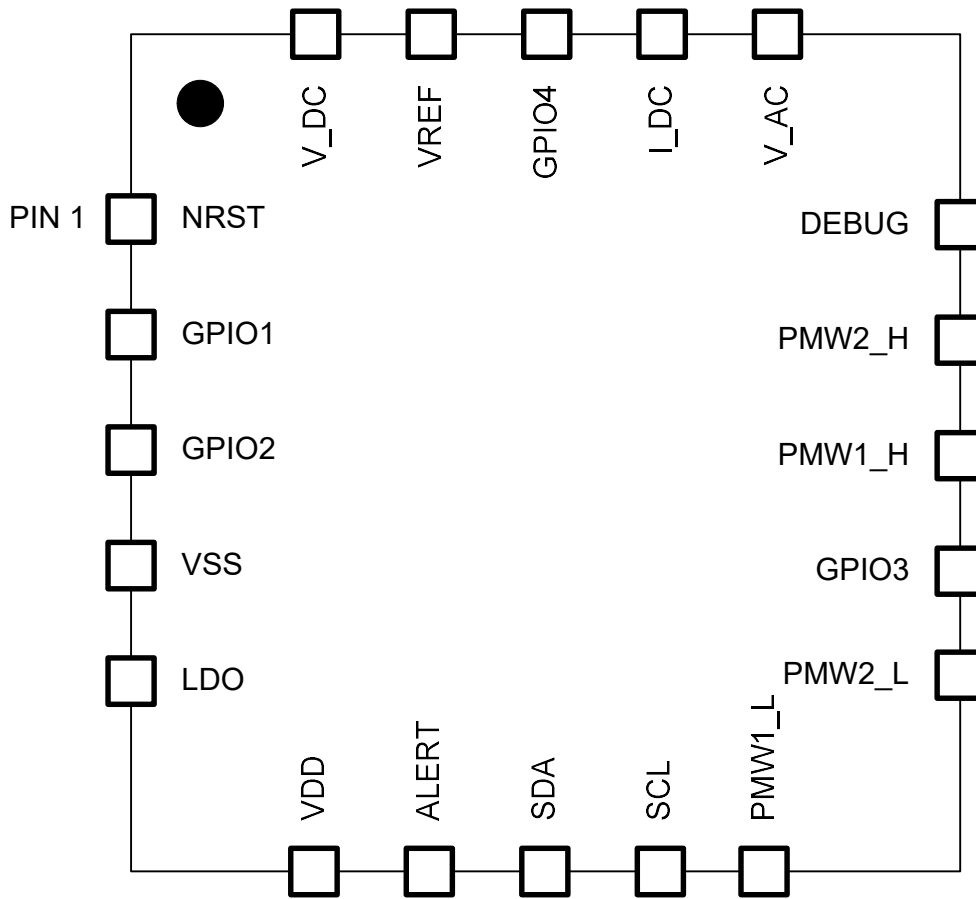

---

## Pin Description

QFN Pin #	Pin Symbol	Function	Description
1	NRST	Reset	Reset input
2	GPIO1	GPIO	GPIO 1
3	GPIO2	GPIO	GPIO 2
4	VSS	Power GND	Power GND
5	LDO	Filter	Internal LDO filter capacitor
6	VDD	Input power	Input power supply
7	ALERT	I2C Alert	I2C Alert signal
8	SDA	I2C Serial Data	I2C Serial Data
9	SCL	I2C Serial Clock	I2C Serial Clock
10	PWM1_L	PWM output	PWM1 low-side control
11	PWM2_L	PWM output	PWM2 low-side control
12	GPIO3	GPIO	GPIO 3
13	PWM1_H	PWM	PWM1 high-side control
14	PWM2_H	PWM	PWM2 high-side control
15	DEBUG	Debug	Debug interface
16	V_AC	Analog GPIO	AC voltage measurement
17	I_DC	Analog GPIO	DC current measurement
18	GPIO4	GPIO	GPIO 4
19	VREF	Analog GPIO	Voltage reference input
20	V_DC	Analog GPIO	DC voltage measurement

# Functional Block Diagram

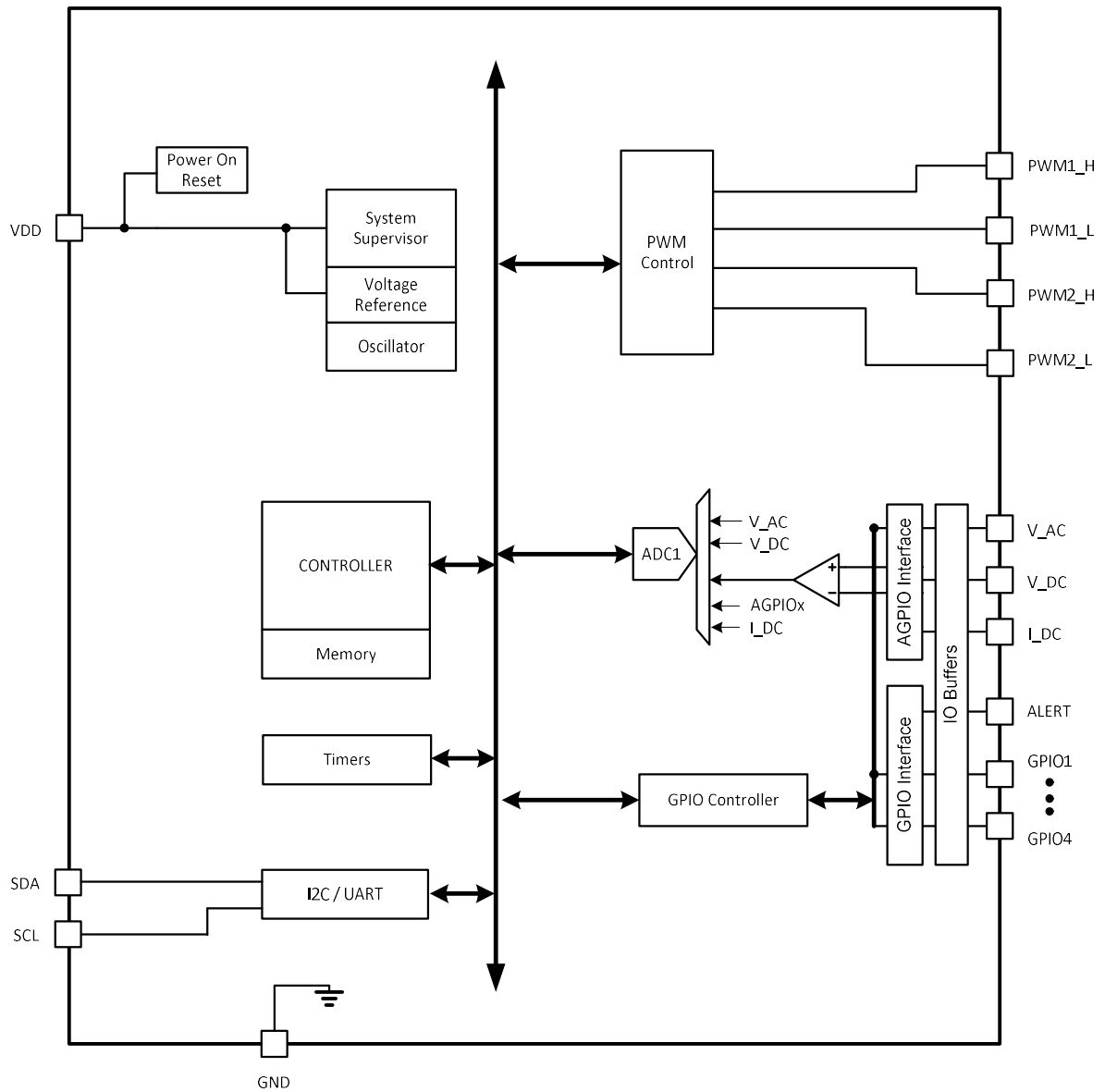

---

## Absolute Maximum Ratings

Over operating free-air temperature range unless otherwise noted <sup>(1, 2, 3)</sup>

Parameter	Min	Max	Unit
VDD, VSS	-0.3	6.5	V
GPIO1, GPIO2, VSS, VDD, ALERT, SDA, SCL, PWM1_L, PWM2_L, GPIO3, PWM1_H, PWM2_H, DEBUG, V_AC, I_DC, GPIO4, VREF, V_DC	VSS - 0.3	6.5	V
NRST, LDO	VSS - 0.3	VDD + 0.3	V
Operating Junction Temperature Range, T <sub>J</sub>	-40	125	°C
Storage Temperature Range, T <sub>STG</sub>	-65	150	°C
Electrostatic Discharge – Human Body Model		±2k	V
IR reflow temperature (soldering, 10 seconds)		260	°C

Notes:

- (1) Stresses beyond those listed under “absolute maximum ratings” may cause permanent damage to the device. These are stress ratings only and functional operation of the device at these or any other conditions beyond those indicated under “recommended operating conditions” is not implied. Exposure to absolute–maximum–rated conditions for extended periods may affect device reliability.
- (2) All voltage values are with respect to network ground terminal.
- (3) ESD testing is performed according to the respective JESD22 JEDEC standard.

## Recommended Operating Conditions

Symbol	Parameter	Min	Typ	Max	Unit
VDD	Input Operating Voltage	2.95		5.5	V
F <sub>MCU</sub>	Operating Frequency	0		16	MHz
VDD	Decoupling capacitor value		1		uF
LDO	Decoupling capacitor value		1		uF
T <sub>A</sub>	Operating Free Air Temperature	-40		85	°C
T <sub>J</sub>	Operating Junction Temperature	-40		105	°C

## Communication Interfaces

The Applications Processor can interrogate the TS80002 using the I2C interface. The TS80002 acknowledges its I2C Slave Address only if it is powered. No ACK from the TS80002 after its slave address means that power is not applied to the TS80002.

---

# I2C

## I2C Signal Pins

ALERT pin (GPIO pin) - optional:

- Driven high when an event is active in the internal STATUS register
- Driven low when all the internal events are cleared

Note: The ALERT pin is provided to help with I2C communication, i.e. to signal events to the EC so the EC can interrogate the TS80002 via I2C. The use of the ALERT pin is not mandatory in the application.

SCL pin:

- Clock pin for the I2C interface.
- True open-drain. Needs external pull-ups.

SDA pin:

- Data pin for the I2C interface.
- True open-drain. Needs external pull-ups.

## I2C Protocol

The TS80002 Wireless Power Receiver acts as an I2C slave peripheral to allow communication with an application microcontroller. The slave address (7 bit) is 0x49. The Embedded Controller is an I2C master and initiates every data transfer.

The TS80002 implements a set of registers available from the I2C bus. It also implements a set of API functions that receive parameters and return values using the I2C bus. Four transfer types are possible:

- Write Register
- Read Register
- Run API Function
- Read API Function Return Buffer

### Write Register Operations

### Description

START				Start of the I2C transfer.
M→S	Slave Address (7 bits)	0 (1 bit)	Slave ACK	Slave address + R/W bit (0x92 as 8-bit).
M→S	Register <i>n</i> address (8 bits)		Slave ACK	Address of the first register.
M→S	Register <i>n</i> Data (8 bits)		Slave ACK	Write the first register.
M→S	Register <i>n+1</i> Data (8 bits)		Slave ACK	Optionally write the following registers.
	...			
M→S	Register <i>n+k</i> Data (8 bits)		Slave ACK	
STOP				Stop of the I2C transfer.

### Read Register Operations

### Description

START				Start of the I2C transfer.
M→S	Slave Address (7 bits)	0 (1 bit)	Slave ACK	Slave address + 0 as R/W bit (0x92 as 8-bit).
M→S	Register <i>n</i> address (8 bits)		Slave ACK	Address of the first register.
START				Repeated Start.
M→S	Slave Address (7 bits)	1 (1 bit)	Slave ACK	Slave address + 1 as R/W bit (0x93 as 8-bit).
S→M	Register <i>n</i> Data (8 bits)		Master ACK	Read the first register.
S→M	Register <i>n+1</i> Data (8 bits)		Master ACK	Optionally read the following registers.
	...			
S→M	Register <i>n+k</i> Data (8 bits)		Master nACK	The master should send a nACK after the last data byte was received.
STOP				Stop of the I2C transfer

## Run API Function

## Description

Start				Start of the I2C transfer.
M→S	Slave Address (7 bits)	0 (1 bit)	Slave ACK	Slave address + R/W bit (0x92 as 8-bit).
M→S	API number (8 bits)		Slave ACK	API number.
M→S	API input buffer length <i>m</i> (8 bits)		Slave ACK	API input buffer length. Equal to 0 if no input buffer data is required by the API.
M→S	Input buffer data[0] (8 bits)		Slave ACK	First byte of the input buffer (optional).
M→S	Input buffer data[1] (8 bits)		Slave ACK	Second byte of the input buffer (optional).
	...			
M→S	Input buffer data[ <i>m-1</i> ] (8 bits)		Slave ACK	Last byte of the input buffer (optional).
Stop				Stop of the I2C transfer and execute the API function.

## Read API Function Return Buffer

## Description

START				Start of the I2C transfer.
M→S	Slave Address (7 bits)	0 (1 bit)	Slave ACK	Slave address + 0 as R/W bit (0x92 as 8-bit).
M→S	API number (8 bits)		Slave ACK	API number.
START				Repeated Start.
M→S	Slave Address (7 bits)	1 (1 bit)	Slave ACK	Slave address + 1 as R/nW bit (0x93 as 8-bit).
S→M	API number (8 bits)		Master ACK	API number for the following return buffer.
S→M	API return buffer length <i>n</i> (8 bits)		Master ACK	API return buffer length.
S→M	Output buffer data[0] (8 bits)		Master ACK	Read the first byte in the output buffer.
S→M	Output buffer data[1] (8 bits)		Master ACK	Optionally read the following bytes.
	...			
S→M	Output buffer data[ <i>n-1</i> ] (8 bits)		Master nACK	The master should send a nACK after the last data byte was received.
STOP				Stop of the I2C transfer

## Internal Registers

Address	Name	Type	Description
0x00	BOOTFW_REV_L	R/W	Bootloader Firmware Revision Low Register
0x01	BOOTFW_REV_H	R/W	Bootloader Firmware Revision High Register
0x02	FW_REV_L	R/W	Firmware Revision Low Register
0x03	FW_REV_H	R/W	Firmware Revision High Register
0x04	MODE_L	R/W	Operating Mode Low Register
0x05	MODE_H	R/W	Operating Mode High Register
0x06	RESET_L	R/W	Reset Low Register
0x07	RESET_H	R/W	Reset High Register
0x08	STATUS	R	Main Status Register
0x09	STATUS0	R	Status0 Register
0x0A	STATUS1	R	Status1 Register
0x0B	STATUS2	R	Status2 Register
0x0C	STATUS3	R	Status3 Register
0x0D-0x7F	RESERVED. Will be defined later.		

### Bootloader Firmware Revision Low Register (BOOTFW\_REV\_L)

Address: 0x00

Reset value: Minor version number of the bootloader firmware

7	6	5	4	3	2	1	0
REV_L[7:0]							
r	r	r	r	r	r	r	r

Bits 7:0 **REV\_L[7:0]**: Bootloader Firmware Revision Low

These bits contain the minor version number of the bootloader firmware.

### Bootloader Firmware Revision High Register (BOOTFW\_REV\_H)

Address: 0x01

Reset value: Major version number of the bootloader firmware

7	6	5	4	3	2	1	0
REV_H[7:0]							
r	r	r	r	r	r	r	r

Bits 7:0 **REV\_H[7:0]**: Bootloader Firmware Revision High

These bits contain the major version number of the bootloader firmware.

### Firmware Revision Low Register (FW\_REV\_L)

Address: 0x02

Reset value: Minor version number of the user firmware

7	6	5	4	3	2	1	0
REV_L[7:0]							
r	r	r	r	r	r	r	r

Bits 7:0 **REV\_L[7:0]**: Firmware Revision Low

These bits contain the minor version number of the user firmware.

### Firmware Revision High Register (BOOTFW\_REV\_H)

Address: 0x03



Reset value: Major version number of the user firmware

7	6	5	4	3	2	1	0
REV_H[7:0]							
r	r	r	r	r	r	r	r

Bits 7:0 **REV\_H[7:0]**: Bootloader Firmware Revision High  
These bits contain the major version number of the user firmware.

#### Operating Mode Low Register (MODE\_L)

Address: 0x04

Reset value: Depends on the bootloader mode and the firmware type

7	6	5	4	3	2	1	0
Res							BOOTLDR
							r

Bits 7:1 Reserved

Bit 0 **BOOTLDR**: Bootloader mode

0: The user firmware is running

1: The controller is in bootloader mode

#### Operating Mode High Register (MODE\_H)

Address: 0x05

Reset value: Depends on the bootloader mode and the firmware type

7	6	5	4	3	2	1	0
Res							

Bits 7:0 Reserved

#### Reset Low Register (RESET\_L)

Address: 0x06

Reset value: 0x00

7	6	5	4	3	2	1	0
RESET_KEY_L[7:0]							
w	w	w	w	w	w	w	w

Bits 7:0 **RESET\_KEY\_L[7:0]**: Reset Key

0x55: generate a system reset. Both the RESET\_L and the RESET\_H registers have to be written with the correct key to generate a reset.

Any other value: a system reset is not generated.

### Reset High Register (RESET\_H)

Address: 0x07

Reset value: 0x00

7	6	5	4	3	2	1	0
RESET_KEY_H[7:0]							
w	w	w	w	w	w	w	w

Bits 7:0 **RESET\_KEY\_H[7:0]**: Reset Key

0xAA: generate a system reset. Both the RESET\_L and the RESET\_H registers have to be written with the correct key to generate a reset.

Any other value: a system reset is not generated.

### Main Status Register (STATUS)

Address: 0x08

Reset value: 0xC0

7	6	5	4	3	2	1	0
CTS	CTS_API	Res		STATUS3	STATUS2	STATUS1	STATUS0
rw	rw			rw	rw	rw	rw

Bit 7 **CTS**: Clear To Send

This bit indicates if a new command can be issued to the controller.

0: The controller is busy processing a previous command. New commands should not be sent to the controller.

1: The controller can accept a new command over the communication interface.

Bit 6 **CTS\_API**: Clear to Send for API

This bit indicates if a new API call can be issued to the controller.

0: The controller is busy processing a previous API call. New API calls should not be sent to the controller.

1: The controller can accept a new API call over the communication interface.

Bits 5:4 Reserved

Bit 3 **STATUS3**: STATUS3 Event Flag

0: No event is signaled in the STATUS3 register

1: An event is signaled in the STATUS3 register

Bit 2 **STATUS2**: STATUS2 Event Flag

0: No event is signaled in the STATUS2 register

1: An event is signaled in the STATUS2 register

Bit 1 **STATUS1**: STATUS1 Event Flag

0: No event is signaled in the STATUS1 register

1: An event is signaled in the STATUS1 register

Bit 0 **STATUS0**: STATUS0 Event Flag

0: No event is signaled in the STATUS0 register

1: An event is signaled in the STATUS0 register

## API Functions

API Number	API Name	Description
0x80	BOOTLOADER_UNLOCK_FLASH	Allow changes to the FLASH memory
0x81	BOOTLOADER_WRITE_BLOCK	Write a page into the FLASH memory
0x82	BOOTLOADER_CRC_CHECK	Check the CRC of the user firmware
0x83-0xFE	RESERVED. Will be defined later.	
0xFF	API_ERROR	Value returned in the API field when a Read API Function Return Buffer command is issued and the API function called previously has generated an error.

### Bootloader Unlock Flash (BOOTLOADER\_UNLOCK\_FLASH)

API number: 0x80  
 Input buffer size: TBD  
 Output buffer size: 1

Buffer	Parameter	Length (bytes)	Description
Input buffer	TBD		
Return data buffer	ERROR_CODE	1	

### Bootloader Write Block (BOOTLOADER\_WRITE\_BLOCK)

API number: 0x81  
 Input buffer size: 66  
 Output buffer size: 1

Buffer	Parameter	Length (bytes)	Description
Input buffer	Block Number	2	Block index. The first block has an index of 0.
	Block Data	64	Data to be written to the FLASH page.
Return data buffer	ERROR_CODE	1	

### Bootloader CRC Check (BOOTLOADER\_CRC\_CHECK)

API number: 0x82  
 Input buffer size: 0  
 Output buffer size: 1

Buffer	Parameter	Length (bytes)	Description
Return data buffer	ERROR_CODE	1	

## API ERROR CODES

Error Code	Error Code Name	Description
0x00	ERROR_GENERIC	Generic error.
0x01	ERROR_OK	Operation succeeded. This is not indicating an error.
0x02	ERROR_INVALID_CRC	CRC error.
0x03	ERROR_FLASH_UNLOCK_FAILED	FLASH unlocking has failed.
0x04	ERROR_API_NOT_IMPLEMENTED	The API number is not implemented.
0x05	ERROR_API_DATA_OVERFLOW	The API input buffer has been filled with more data than its length.
0x06	ERROR_API_INVALID_PARAMETERS	At least one of the API parameters is invalid.

# Application Schematic

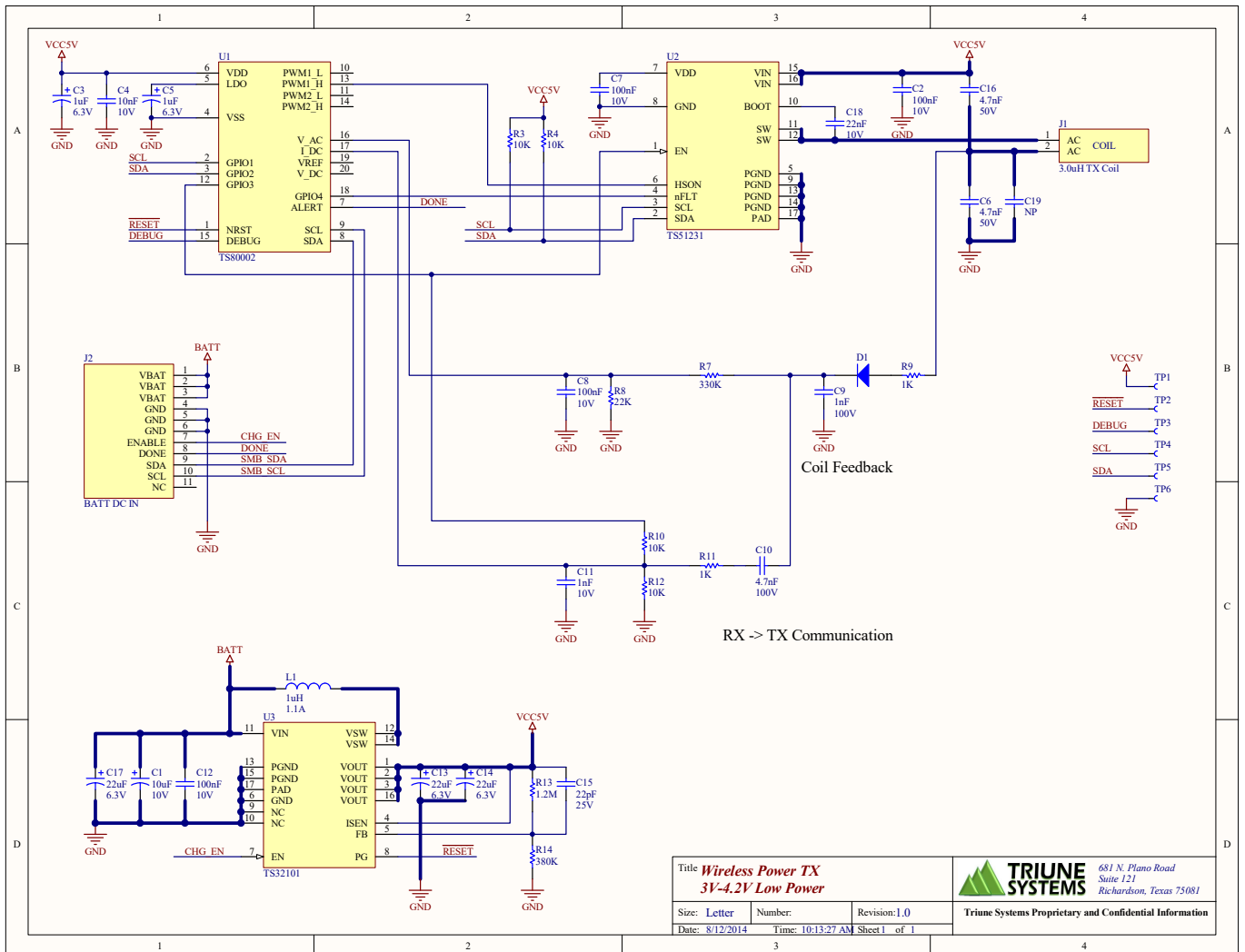
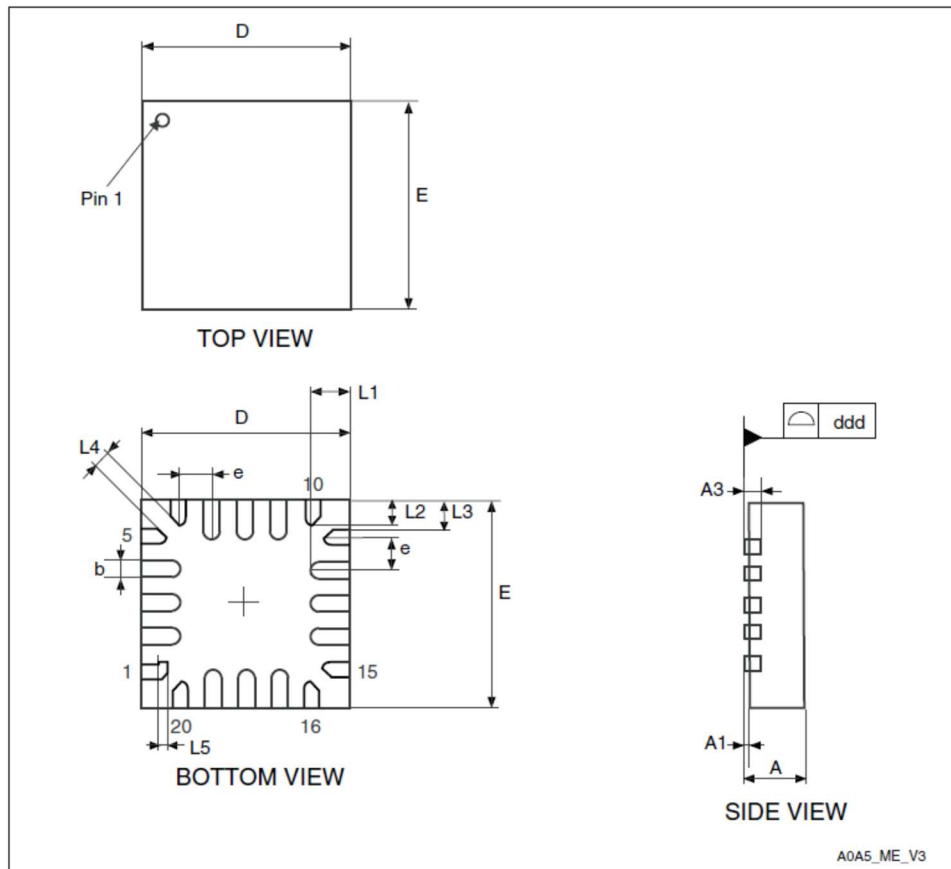

Figure 1: TS80002 Application Schematic

## Package Dimensions



20-lead ultra thin fine pitch quad flat no-lead package outline (3x3)\*  
\*drawing not to scale

20-lead ultra thin fine pitch quad flat no-lead package mechanical data

Symbol	millimeters			inches		
	Min	Typ	Max	Min	Typ	Max
A	0.500	0.550	0.600	0.0197	0.0217	0.0236
A1	0.000	0.020	0.050	0.0000	0.0008	0.0020
A3	-	0.152	-	-	0.060	-
D	-	3.000	-	-	0.1181	-
E	-	3.000	-	-	0.1181	-
L1	0.500	0.550	0.600	0.0197	0.0217	0.0236
L2	0.300	0.350	0.400	0.0118	0.0138	0.0157
L3	-	0.375	-	-	0.0148	-
L4	-	0.200	-	-	0.0079	-
L5	-	0.150	-	-	0.0059	-
b	0.180	0.250	0.300	0.0071	0.0098	0.0118
e	-	0.500	-	-	0.0197	-
ddd	-	-	0.050	-	-	0.0020

20-lead ultra thin fine pitch quad flat no-lead package recommended footprint

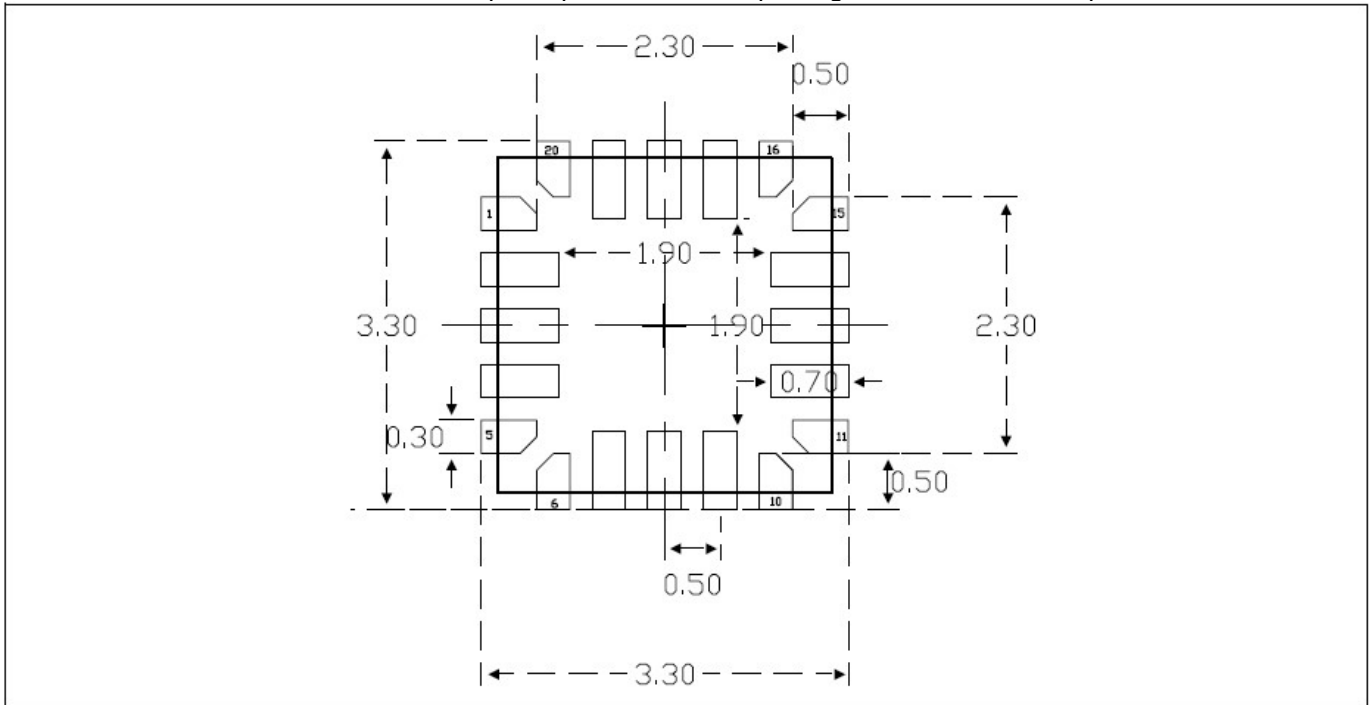

Dimensions are expressed in millimeters

**QFN Package (Top Marking)**

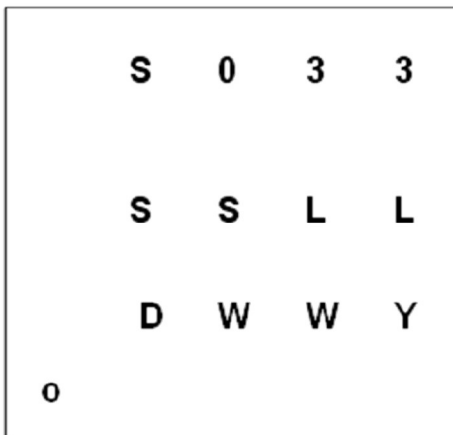

Legend:

Line 1 Marking:	S033	Internal part code
Line 2 Marking:	SS	Assembly site identifier
	LL	Lot trace code
Line 3 Marking:	D	Assembly year
	WW	Assembly week
	Y	Additional marking
	o	Pin 1 Identifier

---

## Ordering Information

Device Part Number	Description
TS80002-QFNR	1W, 1MHz switching

## RoHS and Reach Compliance

Semtech is fully committed to environmental quality. All Semtech materials and suppliers are fully compliant with RoHS (European Union Directive 2011/65/EU), REACH SVHC chemical Restrictions (EC 1907/2006), IPC-1752 Level 3 materials declarations, and their subsequent amendments. Semtech maintains certified laboratory reports for all product materials, from all suppliers, which show full compliance to restrictions on the following:

- Cadmium (Cd)
- Chlorofluorocarbons (CFCs)
- Chlorinated Hydrocarbons (CHCs)
- Halons (Halogen free)
- Hexavalent Chromium (CrVI)
- Hydrobromofluorocarbons (HBFCs)
- Hydrochlorofluorocarbons (HCFCs)
- Lead (Pb)
- Mercury (Hg)
- Perfluorocarbons (PFCs)
- Polybrominated biphenyls (PBB)
- Polybrominated Diphenyl Ethers (PBDEs)



---

## IMPORTANT NOTICE

Information relating to this product and the application or design described herein is believed to be reliable, however such information is provided as a guide only and Semtech assumes no liability for any errors in this document, or for the application or design described herein. Semtech reserves the right to make changes to the product or this document at any time without notice. Buyers should obtain the latest relevant information before placing orders and should verify that such information is current and complete. Semtech warrants performance of its products to the specifications applicable at the time of sale, and all sales are made in accordance with Semtech's standard terms and conditions of sale.

**SEMTECH PRODUCTS ARE NOT DESIGNED, INTENDED, AUTHORIZED OR WARRANTED TO BE SUITABLE FOR USE IN LIFE-SUPPORT APPLICATIONS, DEVICES OR SYSTEMS, OR IN NUCLEAR APPLICATIONS IN WHICH THE FAILURE COULD BE REASONABLY EXPECTED TO RESULT IN PERSONAL INJURY, LOSS OF LIFE OR SEVERE PROPERTY OR ENVIRONMENTAL DAMAGE. INCLUSION OF SEMTECH PRODUCTS IN SUCH APPLICATIONS IS UNDERSTOOD TO BE UNDERTAKEN SOLELY AT THE CUSTOMER'S OWN RISK. Should a customer purchase or use Semtech products for any such unauthorized application, the customer shall indemnify and hold Semtech and its officers, employees, subsidiaries, affiliates, and distributors harmless against all claims, costs damages and attorney fees which could arise.**

The Semtech name and logo are registered trademarks of the Semtech Corporation. All other trademarks and trade names mentioned may be marks and names of Semtech or their respective companies. Semtech reserves the right to make changes to, or discontinue any products described in this document without further notice. Semtech makes no warranty, representation or guarantee, express or implied, regarding the suitability of its products for any particular purpose. All rights reserved.

© Semtech 2016

## Contact Information

---

Semtech Corporation  
200 Flynn Road, Camarillo, CA 93012  
Phone: (805) 498-2111, Fax: (805) 498-3804  
[www.semtech.com](http://www.semtech.com)