

# TS906C2 (20A)

( 200V / 20A )

## LOW LOSS SUPER HIGH SPEED RECTIFIER

### Features

- Surface-mount device
- Low  $V_F$
- Super high speed switching
- High reliability by planer design

### Applications

- High speed power switching

### Maximum ratings and characteristics

- Absolute maximum ratings

Item	Symbol	Conditions	Rating	Unit
Repetitive peak reverse voltage	$V_{RRM}$		200	V
Average output current	$I_O$	Square wave, duty=1/2, $T_c=112^\circ\text{C}$	20*	A
Surge current	$I_{FSM}$	Sine wave 10ms	80	A
Operating junction temperature	$T_j$		-40 to +150	$^\circ\text{C}$
Storage temperature	$T_{stg}$		-40 to +150	$^\circ\text{C}$

\*Average forward current of centertap full wave connection

- Electrical characteristics ( $T_a=25^\circ\text{C}$  Unless otherwise specified )

Item	Symbol	Conditions	Max.	Unit
Forward voltage drop	$V_{FM}$	$I_{FM}=10\text{A}$	0.98	V
Reverse current	$I_{RRM}$	$V_R=V_{RRM}$	200	$\mu\text{A}$
Reverse recovery time	$t_{rr}$	$I_F=0.1\text{A}$ , $I_R=0.2\text{A}$ , $I_{rec}=0.05\text{A}$	35	ns
Thermal resistance	$R_{th(j-c)}$	Junction to case	2.0*	$^\circ\text{C/W}$

### Outline drawings, mm

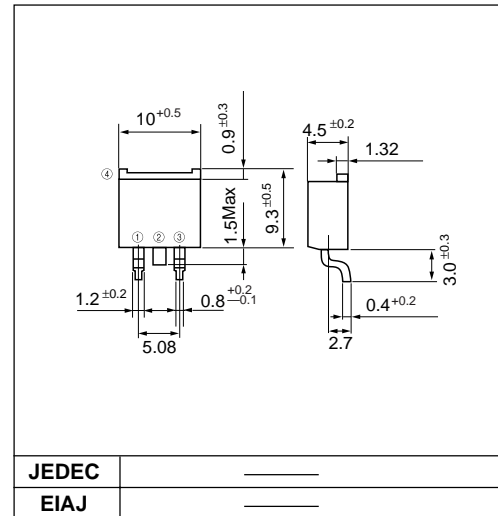

### Connection diagram

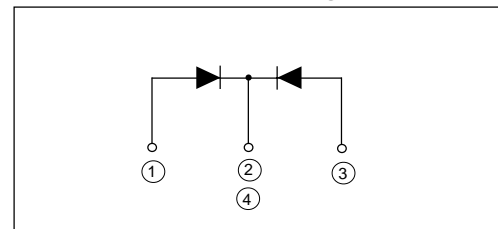

Characteristics

Forward characteristics

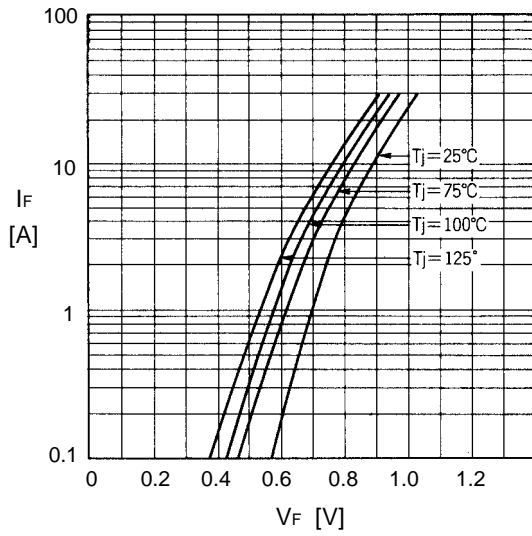

Reverse characteristics

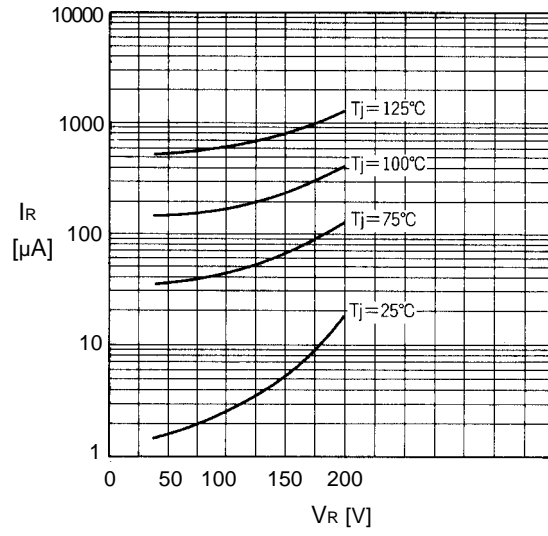

Forward power dissipation

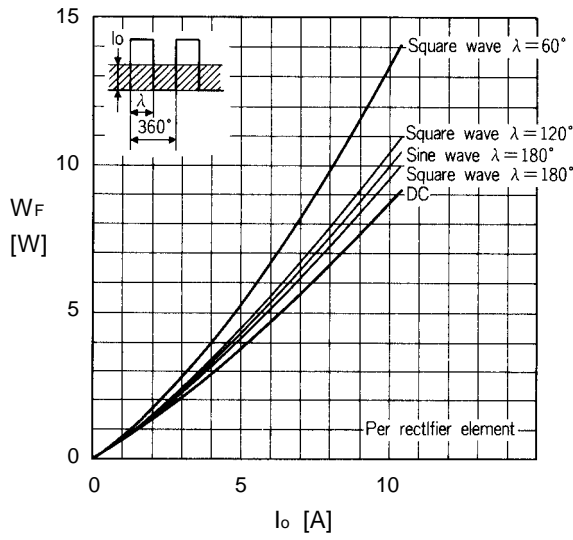

Output current-case temperature

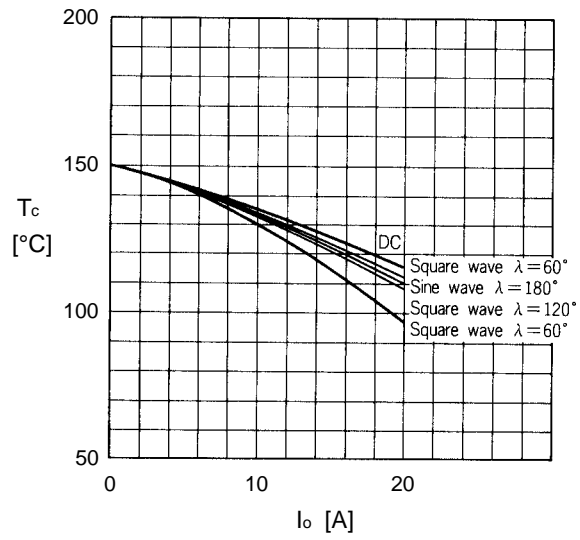

Junction capacitance characteristics

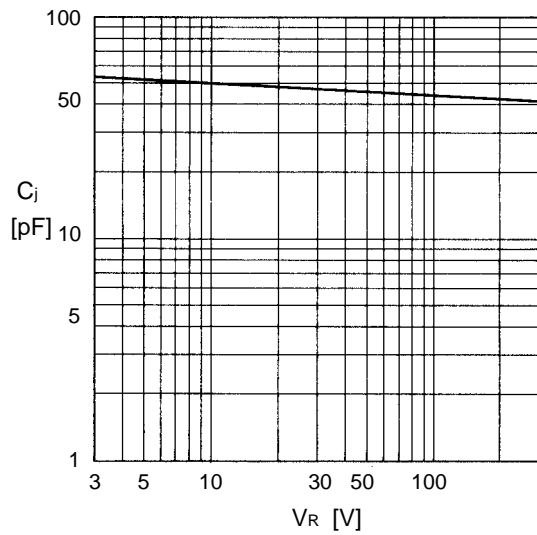

Surge capability

