

Integrated Analog Front-End for Heart Rate Monitors and Low-Cost Pulse Oximeters

Features

- **Fully-Integrated Analog Front-End for Pulse Oximeter Applications**
- **Receiver:**
High Accuracy Current to Frequency Converter up to 500KHz
Automatic Ambient Light Cancellation
- **Transmitter:**
Flexible Pulse Sequencing and Timing Control with Integrated LED Driver (H-Bridge)
LED Currents Programmable with an External Resistor and the SPI Interface
7-Bit Resolution with 95dB Dynamic Range
- **Power Supplies: 2.5V to 5.5V**
Low Power: 1.2 mA at 3.3V Supply
- **Specified Temperature Range: -40°C to +85°C**
- **Package: TSSOP16, QFN16**

Applications

- Low-Cost Medical Pulse Oximeter Applications
- Optical HRM

Product Description

The TS9517 is a fully-integrated analog front-end (AFE) that is ideally suited for pulse Oximeter applications. The device consists of a low-noise I/F converter and a LED transmitter section. The I/F converter converts photodiode current to frequency signal. The LED transmitter currents can be easily controlled through the SPI™ interface. The TS9517's flexibility allows users to have complete control of the device's timing characteristics. The TS9517 is an AFE solution in TSSOP16 and QFN16 packages and is specified over the operating temperature from -40°C to +85°C.

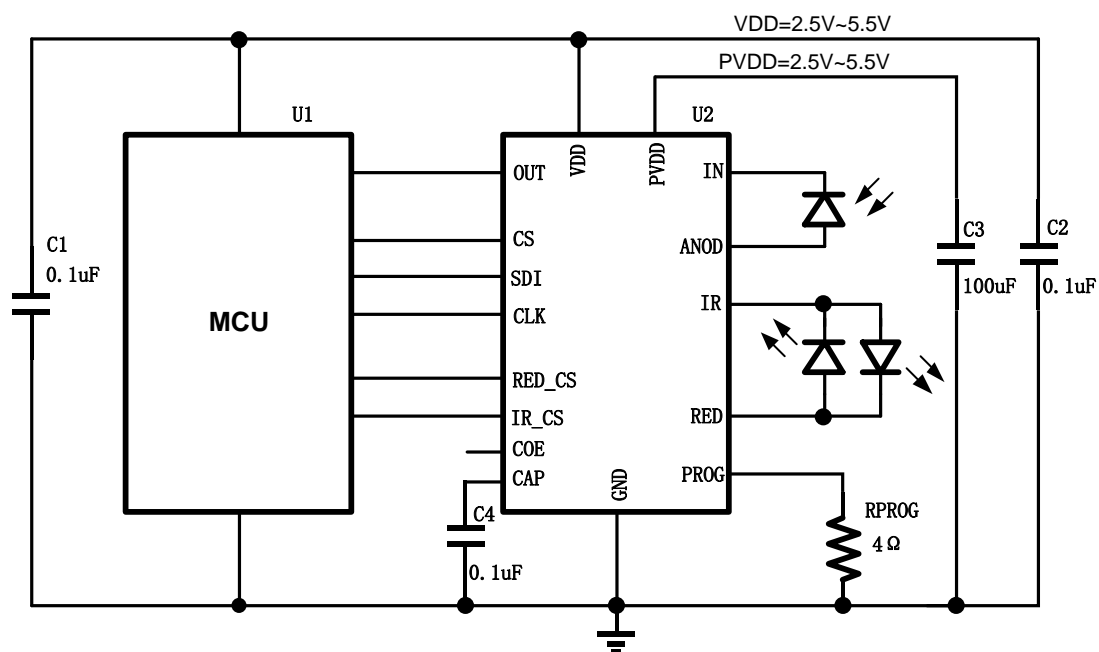

Ordering Information

Product	Package-Lead	Package Option	Package Qty.	Operating Temperature Range
TS9517EQR	QFN16	Tape and Reel	5000	-40°C to +85°C
TS9517ETR	TSSOP16	Tape and Reel	2500	-40°C to +85°C

Absolute Maximum Ratings

Over operating free-air temperature range, unless otherwise noted.

		Value	Unit
VDD to GND		2.5 to 5.5	V
Input current to any pin except supply pins		±10	mA
Input current	Momentary	±50	mA
	Continuous	±10	mA
Operating temperature range		-40 to +85	°C
Storage temperature range		-65 to +150	°C
Maximum junction temperature, T _J		+125	°C
Electrostatic discharge (ESD) ratings	Human body model (HBM)	±2000	V
	Machine model (MM)	±200	V
	Charge device model(CDM)	±500	V

ESD CAUTION



ESD (electrostatic discharge) sensitive device. Charged devices and circuit boards can discharge without detection. Although this product features patented or proprietary protection circuitry, damage may occur on devices subjects to high energy ESD. Therefore, proper ESD precautions should be taken to avoid performance degradation or loss of functionality.

PIN Configuration

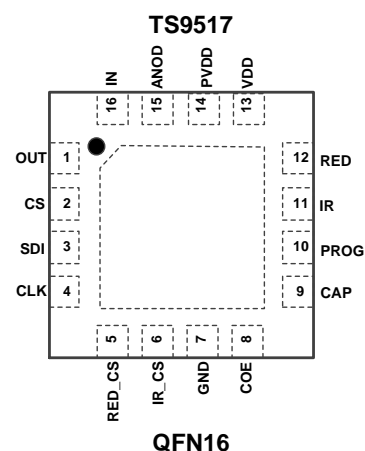
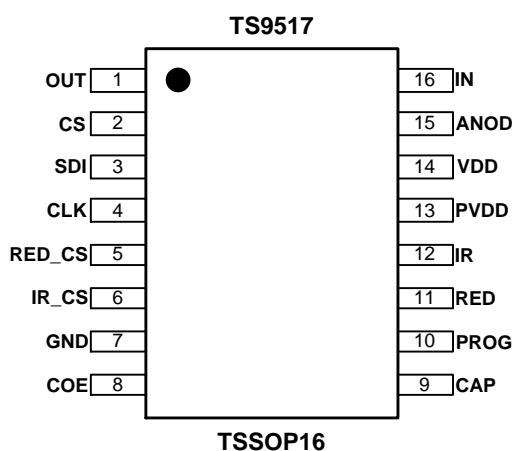

Table 1. PIN Descriptions

NO. (TSSOP16)	NO. (QFN16)	Name	Function	Description
1	1	OUT	Output	Frequency output
2	2	CS	Input	SPI chip select
3	3	SDI	Input	SPI data input
4	4	CLK	Input	SPI clock input
5	5	RED_CS	Input	RED LED control input. High active
6	6	IR_CS	Input	IR LED Control Input. High active
7	7	GND	Supply	Supply ground pin
8	8	COE	Input	Ambient light cancellation selection, COE=High, enable ambient light cancellation; COE=Low, disable ambient light cancellation. An internal 200KΩ pull-up resistor at this pin.
9	9	CAP	Input	Connect a 0.1 μF capacitor to GND
10	10	PROG	I/O	LED driver current program pin, connect a resistor to this Pin
11	12	RED	Output	RED LED drive output
12	11	IR	Output	IR LED drive output
13	14	PVDD	Supply	LED driver power supply pin
14	13	VDD	Supply	Power supply pin
15	15	ANOD	Input	Current input, connect to PIN diode anode
16	16	IN	Input	Current input, connect to PIN diode cathode

Electrical Characteristics

Minimum and maximum specification are at $T_A = -40^\circ\text{C}$ to $+85^\circ\text{C}$. Typical specifications are at $+25^\circ\text{C}$.

All specifications are at $V_{DD} = 3.3\text{V}$, unless otherwise noticed.

Parameter	Test Conditions	Min	Typ	Max	Unit	
Performance (Full-Signal Chain)						
V_{DD}	Supply voltage	0°C to +85°C		2.5	5.5	V
V_{DD}	Supply voltage	-40°C to +85°C		2.7	5.5	V
PV_{DD}	LED driver supply voltage ¹			2.5	5.5	V
I_{DD}	Supply current	VDD=5.5V		1.25	1.7	mA
PRF	Pulse repetition frequency			1000		SPS
I-F Transimpedance Amplifier						
f_o	Output frequency	$I_{IN} = 1\mu\text{A}$		100		kHz
	Full-scale frequency			500	1000	kHz
	Nonlinearity	$f_o = 0\text{KHz to } 10\text{KHz}$		$\pm 1\%$		%FS
R_e	Current responsivity			100		kHz/ μA
PSRR	Power-supply rejection ratio	Without ambient light cancellation, $f = 100\text{KHz}$		0.3		%/V
		With ambient light cancellation, $f = 100\text{KHz}$		0.8		%/V
I_c	Maximum ambient light cancellation current			5	10	μA
Transmitter						
	Full-scale output current ¹	$T_A = 25^\circ\text{C}$ $V_{DD} = 5\text{V}$, $R_{PROG} = 4\Omega$		170	200	mA
	Output current resolution			7		Bits
	Output current offset	$V_{DD} = 5\text{V}$, $R_{PROG} = 4\Omega$		0.25	1.25	mA
	Transmitter noise dynamic range, over 0.1Hz to 5Hz bandwidth	At 5mA output current		TBD		dB
		At 25mA output current		TBD		dB
		At 50mA output current		TBD		dB
	Minimum on time of RED-LED			50		μs
	LED current DAC linearity	Percent of full-scale current		1%		
	Output current settling time (with resistive load)	From zero current to 50 mA		TBD		μs
		From 50 mA to zero current		TBD		μs
Temperature						
	Specified temperature range			-40	+85	°C
	Storage temperature range			-65	+150	°C

1. The Maximum LED output current depends on PV_{DD} , R_{PROG} resistance and LED forward voltage strongly; it can be smaller than the full-scale current.

Overview

The TS9517 is a complete analog front-end (AFE) circuit targeting pulse oximeter applications. The device consists of a low-noise I/F converter and a LED transmitter section. The I/F converter converts the photodiode current to frequency signal precisely. The output of the device connects directly to a high resolution timer of the external microcontroller (MCU) for which an A/D converter is not necessary. The LED transmitter current can be programmed through the SPI™ interface.

Receiver

The receiver consists of a high precision current-to-frequency (I-F) converter section and an ambient light cancellation (ALC) circuitry. The I/F converter converts the photodiode current to frequency signal with high dynamic range and linearity. The ALC function can be enabled or disabled by the COE pin. When COE pin is set low, the ALC function is disabled; the converter continuously converts input current to frequency without being interrupted by the LED control signals. In this mode, currents from both the ambient light and the signal light are converted at the same time. When COE pin is set high or floating, the ALC function is enabled, the operation of the I/F converter is in synchronization with the LED control signals. When none of the LEDs are turned on, the receiver is in ambient light measurement mode in which the I/F converter stops operation; when one of conversion mode and the I/F converter resume operation in which only the current from the signal light is converted.

Transmitter Section

The transmitter section integrates a programmable constant current source, an H-bridge LED driver and its control logic. Two LED driver schemes are supported: an H-bridge driver for a two-terminal device with two reverse-paralleled LEDs, or two push-pull drivers for a three-terminal device with two LEDs packaged together. The on-off of the LED

current is controlled by logic signals at the input pins of RED_CS and IR_CS, both of which are active 'high' and each LED current can be adjusted by a 7-bit DAC which can be programmed by the SPI interface. An external resistor R_{PROG} at the PROG pin sets the ratio of the LED current to the input of the DAC, the maximum output current is primarily dependent on R_{PROG} , the power supply voltage PV_{DD} , and the forward voltage of the LEDs.

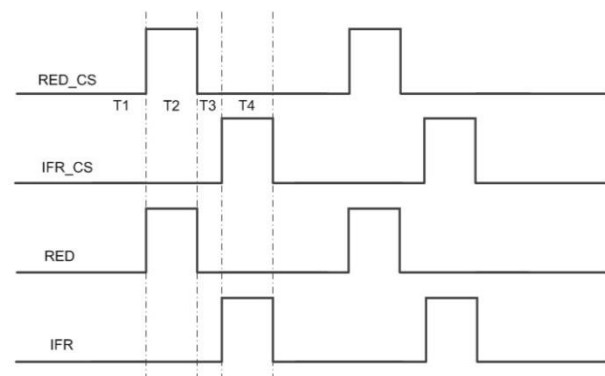

Figure 1. Timing of LED Control and ALC.

LED Current Control

The output currents of the transmitter are controlled by the internal 7-bit DAC. The currents cover the range of 0 ~ 200mA and are given by the following equation:

$$I_{LED} = \frac{N \times V_{LSB}}{R_{PROG}}$$

where N is the input of the DAC with a range from 0 ~ 127, which can be programmed by the SPI interface (see SPI interface); V_{LSB} is the output of the DAC corresponding to the LSB of the input which is about 8 mV; R_{PROG} is the resistance of R_{PROG} which is user selectable.

Timing Diagram of the Transmitter

Figure 1 shows the timing diagram for the LED transmitter control. Through the internal logic, signals at the RED_CS and IR_CS pins control the switches of the H-Bridge. In T1 and T3 cycles, both LEDs are turned off (ALC mode). In T2 and T4 cycles, RED LED and IR LED are turned on respectively (conversion

mode). It should be noted that, however, when both signals at the pins of RED_CS and IR_CS are high at the same time, there will be no current flowing through the two-terminal back-to-back packaged LEDs (see Table 2 and Table 3).

SPI interface and internal register

TS9517 integrates an 8-bit serial latch and two 8-bit registers. The latch takes the serial input data through

the SPI interface and the registers store the input data for RED and IR LED currents accordingly. Figure 2 shows the timing of the SPI, where D7 is the first bit and D0 is the last bit (address bit). When CS is low, the SPI interface is enabled, each bit is received at the rising edge of CLK. At the rising edge of CS, the data is latched to one of the registers pointed by bit D0 and the corresponding transmitter current is refreshed. The description of the registers is shown in Table 4.

Table 2. Transmitter True Table (two-terminal back-to-back packaged LEDs)

Inputs		Outputs			
RED_CS	IR_CS	RED	IR	RED Transmit	IR Transmit
0	0	Z	Z	OFF	OFF
1	0	H	L	ON	OFF
0	1	L	H	OFF	ON
1	1	H	H	OFF	OFF

Table 3. Timing Requirements

Parameter		Min	Typ	Max	Unit
t _{RED_CS}	Red LED on time, active high	50			μs
t _{IR_CS}	Infrared LED on time, active high	50			μs
t _{INT}	The time interval between Red LED on and IR LED on	50			μs

Table 4. LEDCUR: LED Current Register and Latch

D7	D6	D5	D4	D3	D2	D1	D0
LEDCUR[7:1]							ADDR

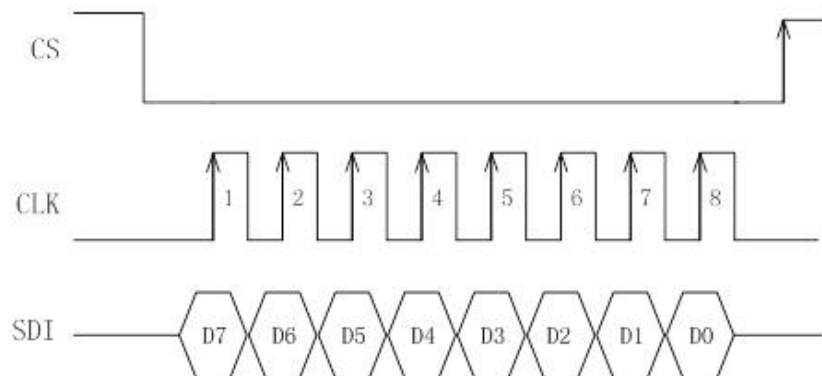

Figure 2. SPI timing diagram

Application Examples

Figure 3 and Figure 4 show typical applications of TS9517 as analog front-end for pulse oximeters. Please note that the pins of 11 and 12 and pins of 13 and 14 are interchanged between the two packages.

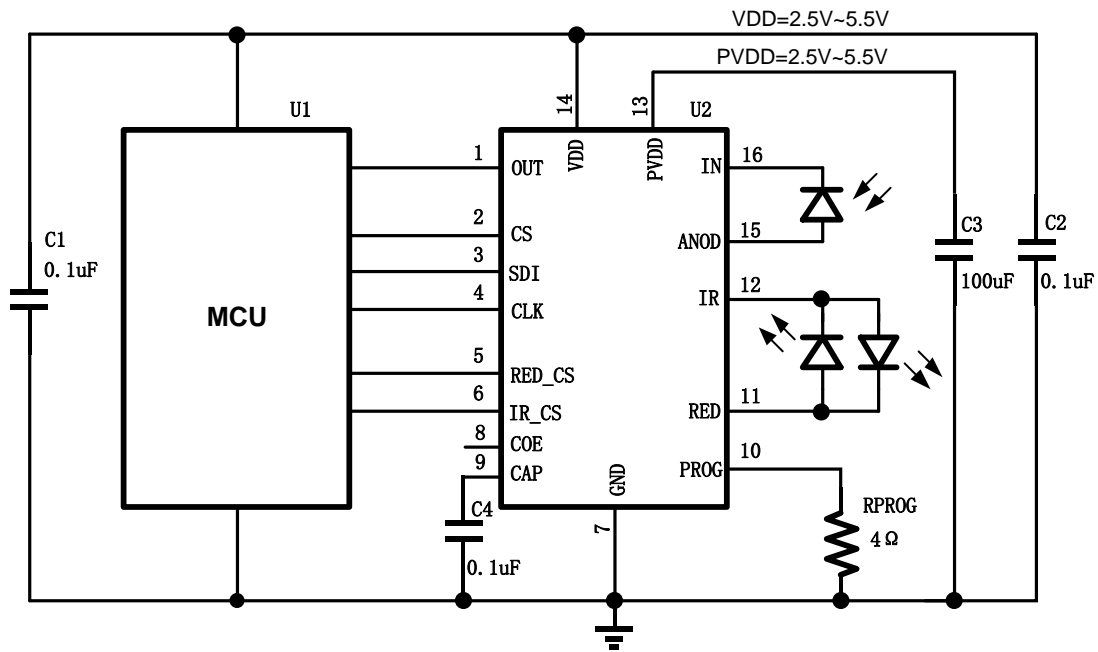

Figure 3. Typical Application of TS9517 in TSSOP16 Package

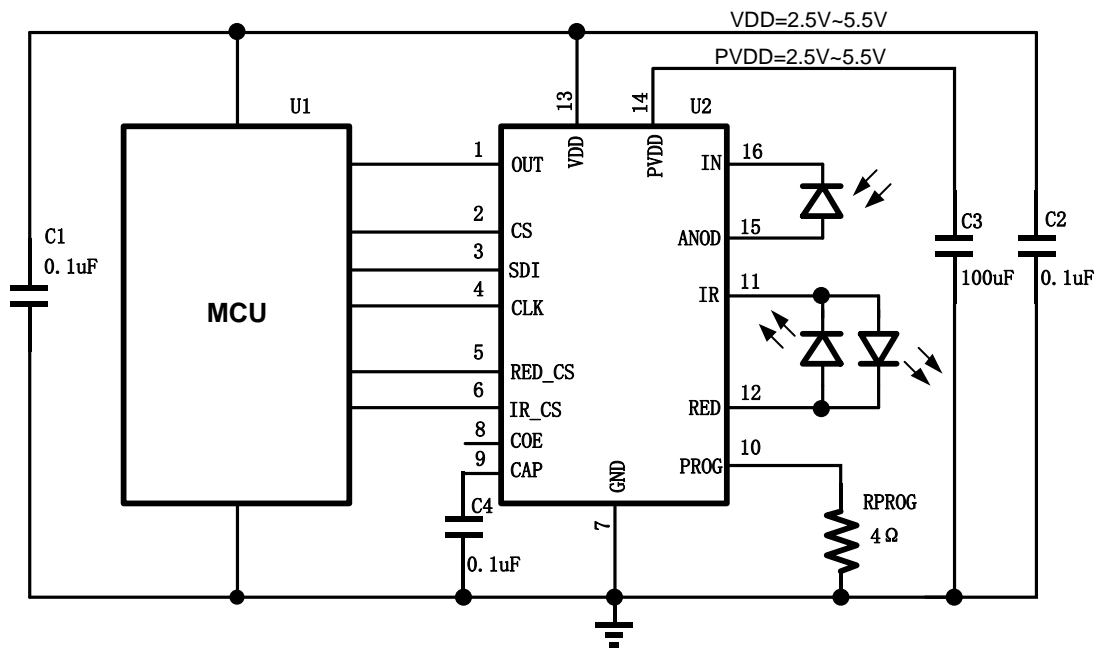
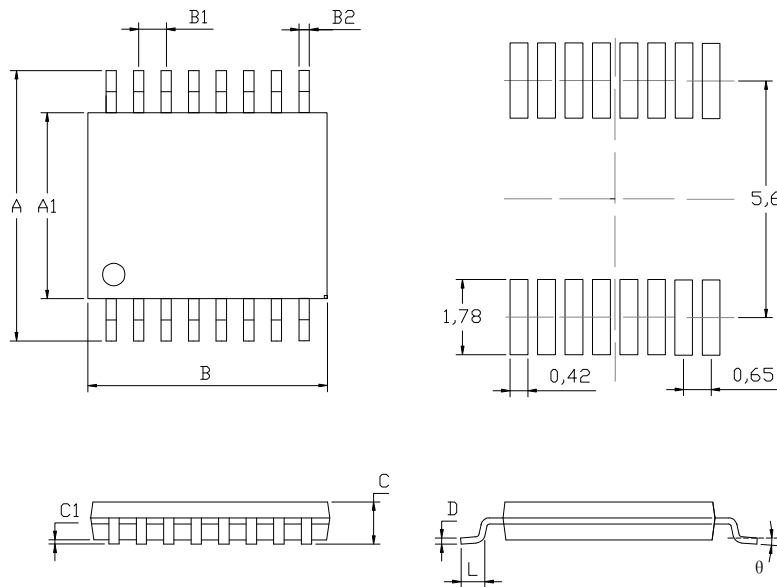

Figure 4. Typical Application of TS9517 in QFN16 Package

Mechanical Dimensions

TSSOP-16 PACKAGE MECHANICAL DRAWING



TSSOP-16 PACKAGE MECHANICAL DATA

symbol	dimensions			
	millimeters		inches	
	min	max	min	max
A	6.2	6.6	0.2441	0.2598
A1	4.3	4.5	0.1693	0.1772
B	4.9	5.1	0.1929	0.2008
B1	0.65		0.0256	
B2	0.19	0.3	0.0075	0.0118
C		1.20MAX		0.0472MAX
C1	0.05	0.15	0.0020	0.0059
L	0.5	0.75	0.0197	0.0295
D	0.1	0.2	0.0039	0.0079
theta	0°	8°	0°	8°

QFN-16 PACKAGE MECHANICAL DRAWING

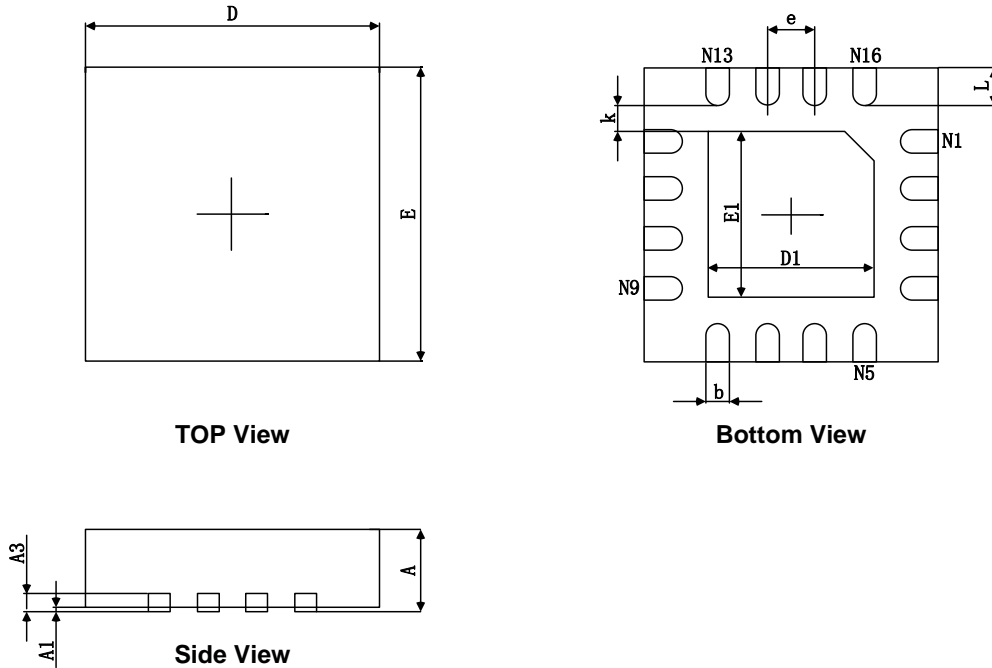

QFN-16 PACKAGE MECHANICAL DATA

symbol	dimensions			
	millimeters		inches	
	min	max	min	max
A	0.700/0.800	0.800/0.900	0.028/0.031	0.031/0.035
A1	0.000	0.050	0.000	0.002
A3	0.203REF.		0.008REF.	
D	2.924	3.076	0.115	0.121
E	2.924	3.076	0.115	0.121
D1	1.600	1.800	0.063	0.071
E1	1.600	1.800	0.063	0.071
k	0.200MIN.		0.008MIN	
b	0.180	0.280	0.007	0.011
e	0.500TYP.		0.020TYP.	
L	0.324	0.476	0.013	0.019

CONTACT INFORMATION

Trusignal Microelectronics

328 Xinghu Street, Suite 22-207, Suzhou Industrial Park, Suzhou, 215123, PR China

Email: support@trusignal.com; sales@trusignal.com

Phone: +86 0512-65923982

Fax: +86 0512-65923995