



SD2931-10

RF POWER TRANSISTORS HF/VHF/UHF N-CHANNEL MOSFETs

ADVANCE DATA

- v GOLD METALLIZATION
- v EXCELLENT THERMAL STABILITY
- v COMMON SOURCE CONFIGURATION
- v POUT = 150W MIN. WITH 14 dB gain @175 MHz
- v THERMALLY ENHANCED PACKAGING FOR LOWER JUNCTION TEMPERATURES

DESCRIPTION

The SD2931-10 is a gold metallized N-Channel MOS field-effect RF power transistor. Being electrically identical to the standard SD2931 MOSFET, it is intended for use in 50V dc large signal applications up to 230 MHz.

The SD2931-10 is mechanical compatible to the SD2931 but offers in addition a better thermal capability (25 % lower thermal resistance), representing the best-in-class transistors for ISM applications.

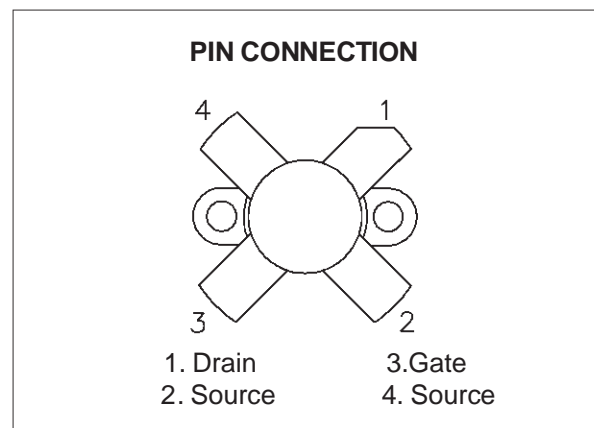
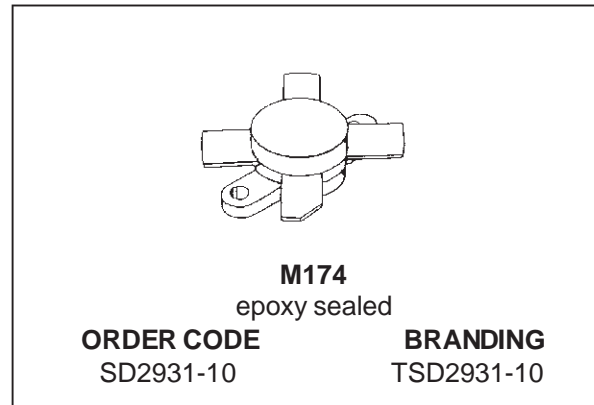

ABSOLUTE MAXIMUM RATINGS ($T_{case} = 25^{\circ}C$)

| Symbol | Parameter | Value | Unit |
|---------------|--|------------|-------------|
| $V_{(BR)DSS}$ | Drain Source Voltage | 125 | V |
| V_{DGR} | Drain-Gate Voltage ($R_{GS} = 1M\Omega$) | 125 | V |
| V_{GS} | Gate-Source Voltage | ± 20 | V |
| I_D | Drain Current | 20 | A |
| P_{DISS} | Power Dissipation | 389 | W |
| T_j | Max. Operating Junction Temperature | 200 | $^{\circ}C$ |
| T_{STG} | Storage Temperature | -65 to 150 | $^{\circ}C$ |

THERMAL DATA

| | | | |
|---------------|------------------------------------|------|---------------|
| $R_{th(j-c)}$ | Junction-Case Thermal Resistance | 0.45 | $^{\circ}C/W$ |
| $R_{th(c-s)}$ | Case-Heatsink Thermal Resistance * | 0.2 | $^{\circ}C/W$ |

* Determined using a flat aluminum or copper heatsink with thermal compound applied (Dow Corning 340 or equivalent).

ELECTRICAL SPECIFICATION ($T_{case} = 25\text{ }^{\circ}\text{C}$)

STATIC

| Symbol | Parameter | | Min. | Typ. | Max. | Unit |
|---------------|----------------|--------------------------|------|------|------|---------------|
| $V_{(BR)DSS}$ | $V_{GS} = 0V$ | $I_{DS} = 100\text{ mA}$ | 125 | | | V |
| I_{DSS} | $V_{GS} = 0V$ | $V_{DS} = 50\text{ V}$ | | | 5 | mA |
| I_{GSS} | $V_{GS} = 20V$ | $V_{DS} = 0\text{ V}$ | | | 5 | μA |
| $V_{GS(Q)^*}$ | $V_{DS} = 10V$ | $I_D = 250\text{ mA}$ | 2.0 | | 5.0 | V |
| $V_{DS(ON)}$ | $V_{GS} = 10V$ | $I_D = 10\text{ A}$ | | | 3.0 | V |
| G_{FS} | $V_{DS} = 10V$ | $I_D = 5\text{ A}$ | 5 | | | mho |
| C_{ISS} | $V_{GS} = 0V$ | $V_{DS} = 50\text{ V}$ | | 480 | | pF |
| C_{OSS} | $V_{GS} = 0V$ | $V_{DS} = 50\text{ V}$ | | 190 | | pF |
| C_{RSS} | $V_{GS} = 0V$ | $V_{DS} = 50\text{ V}$ | | 18 | | pF |

* $V_{GS(Q)}$ sorted with alpha/numeric code marked on unit.

REF. 7165489C

DYNAMIC

| Symbol | Parameter | | Min. | Typ. | Max. | Unit |
|---------------|---|--|------|------|------|------|
| P_{OUT} | $f = 175\text{ MHz}$ | $V_{DD} = 50\text{ V}$ $I_{DQ} = 250\text{ mA}$ | 150 | | | W |
| G_{PS} | $f = 175\text{ MHz}$ | $V_{DD} = 50\text{ V}$ $P_{out} = 150\text{ W}$ $I_{DQ} = 250\text{ mA}$ | 14 | 15 | | dB |
| η_D | $f = 175\text{ MHz}$ | $V_{DD} = 50\text{ V}$ $P_{out} = 150\text{ W}$ $I_{DQ} = 250\text{ mA}$ | 55 | 65 | | % |
| Load Mismatch | $f = 175\text{ MHz}$ $V_{DD} = 50\text{ V}$ $P_{out} = 150\text{ W}$ $I_{DQ} = 250\text{ mA}$ All Phase Angles | | 10:1 | | | VSWR |

IMPEDANCE DATA

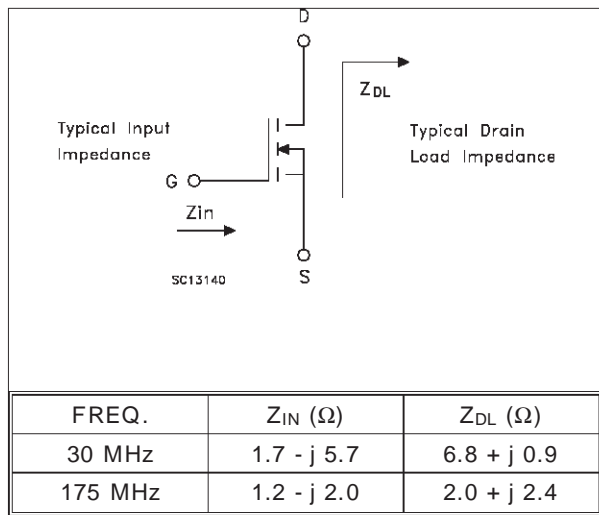

V_{GS} SORTS

| | | | |
|---|-----------|---|-----------|
| A | 2.0 - 2.1 | R | 3.5 - 3.6 |
| B | 2.1 - 2.2 | S | 3.6 - 3.7 |
| C | 2.2 - 2.3 | T | 3.7 - 3.8 |
| D | 2.3 - 2.4 | U | 3.8 - 3.9 |
| E | 2.4 - 2.5 | V | 3.9 - 4.0 |
| F | 2.5 - 2.6 | W | 4.0 - 4.1 |
| G | 2.6 - 2.7 | X | 4.1 - 4.2 |
| H | 2.7 - 2.8 | Y | 4.2 - 4.3 |
| J | 2.8 - 2.9 | Z | 4.3 - 4.4 |
| K | 2.9 - 3.0 | 2 | 4.4 - 4.5 |
| L | 3.0 - 3.1 | 3 | 4.5 - 4.6 |
| M | 3.1 - 3.2 | 4 | 4.6 - 4.7 |
| N | 3.2 - 3.3 | 5 | 4.7 - 4.8 |
| P | 3.3 - 3.4 | 6 | 4.8 - 4.9 |
| Q | 3.4 - 3.5 | 7 | 4.9 - 5.0 |

TYPICAL PERFORMANCE

Capacitance vs Drain-Source Voltage

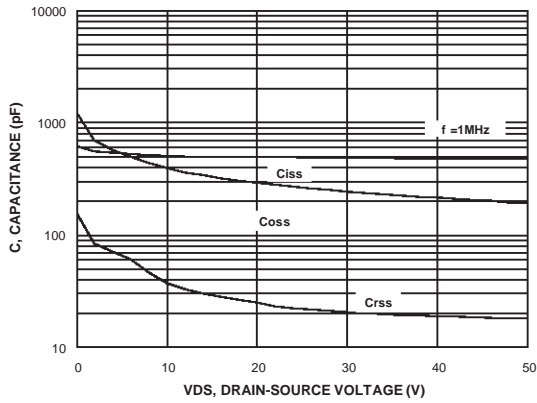

Drain Current vs Gate Voltage

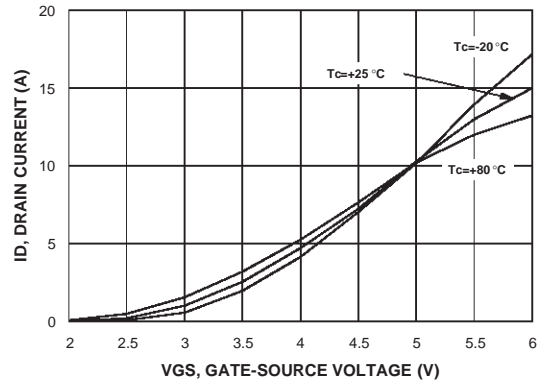

Gate-Source Voltages vs Case Temperature

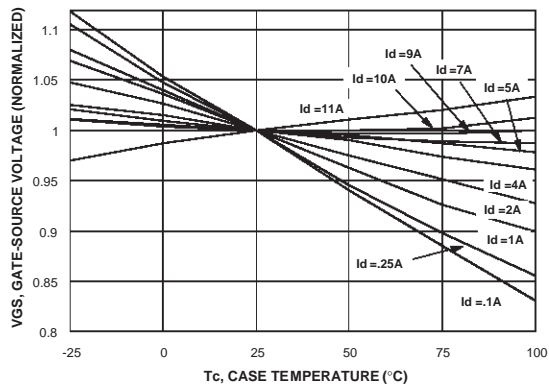

Maximum Thermal Resistance vs Case Temperature

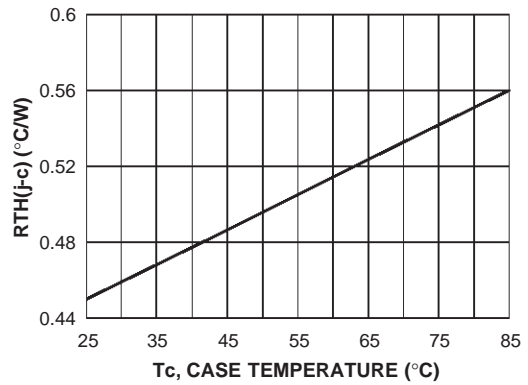

DC Safe Operating Area

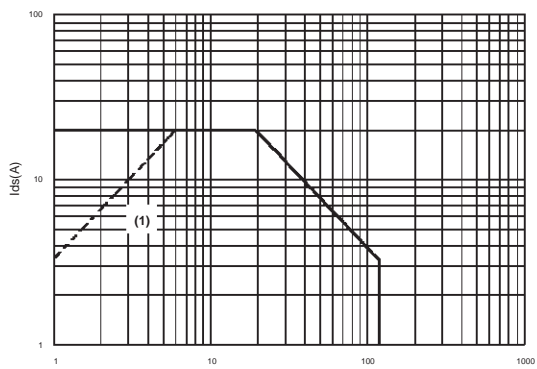

(1) Current in this area may be limited by $R_{ds(on)}$



TYPICAL PERFORMANCE (175 MHz)

Output Power vs Input Power

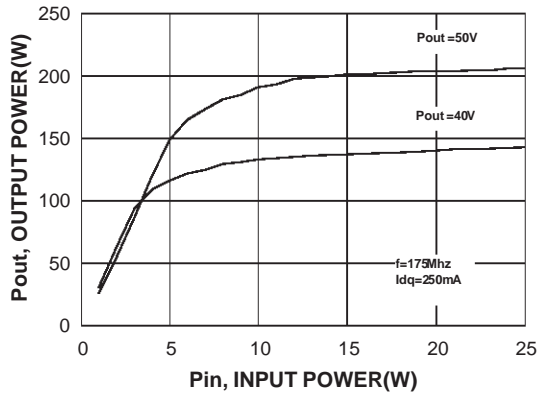

Output Power vs Input Power

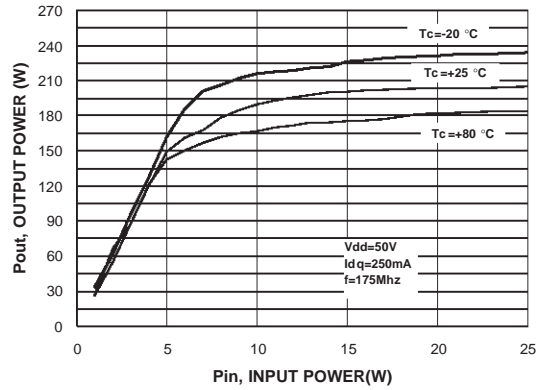

Power Gain vs Output Power

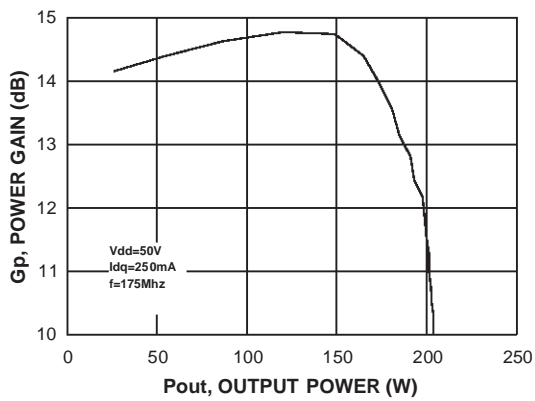

Efficiency vs Output Power

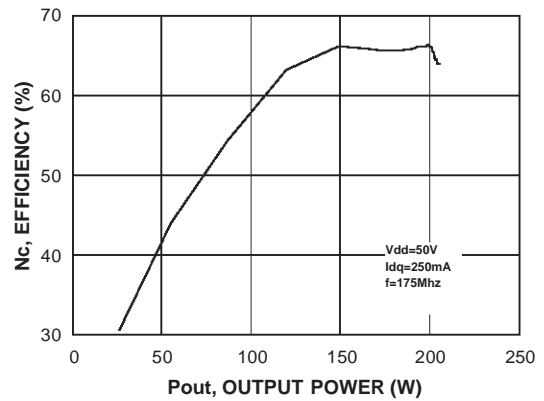

Output Power vs Supply Voltage

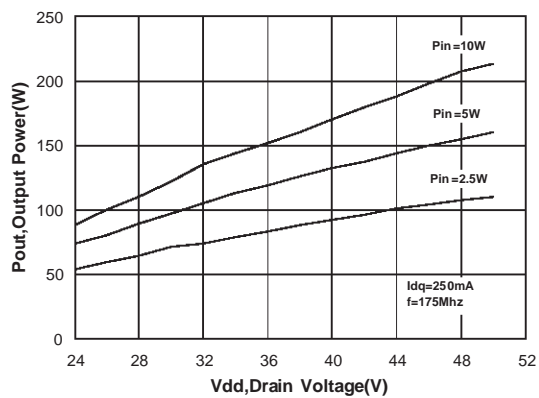

Output Power vs Gate Voltage

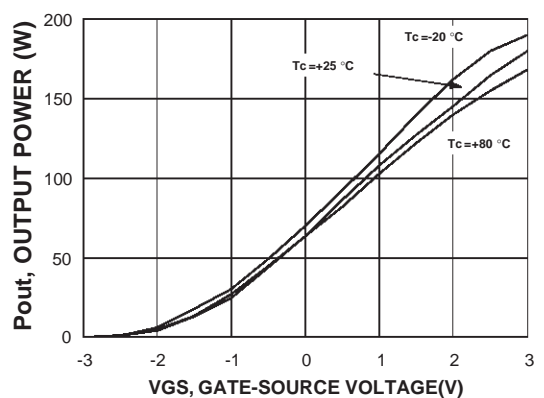

175 MHz Test Circuit Schematic (Production Test Circuit)

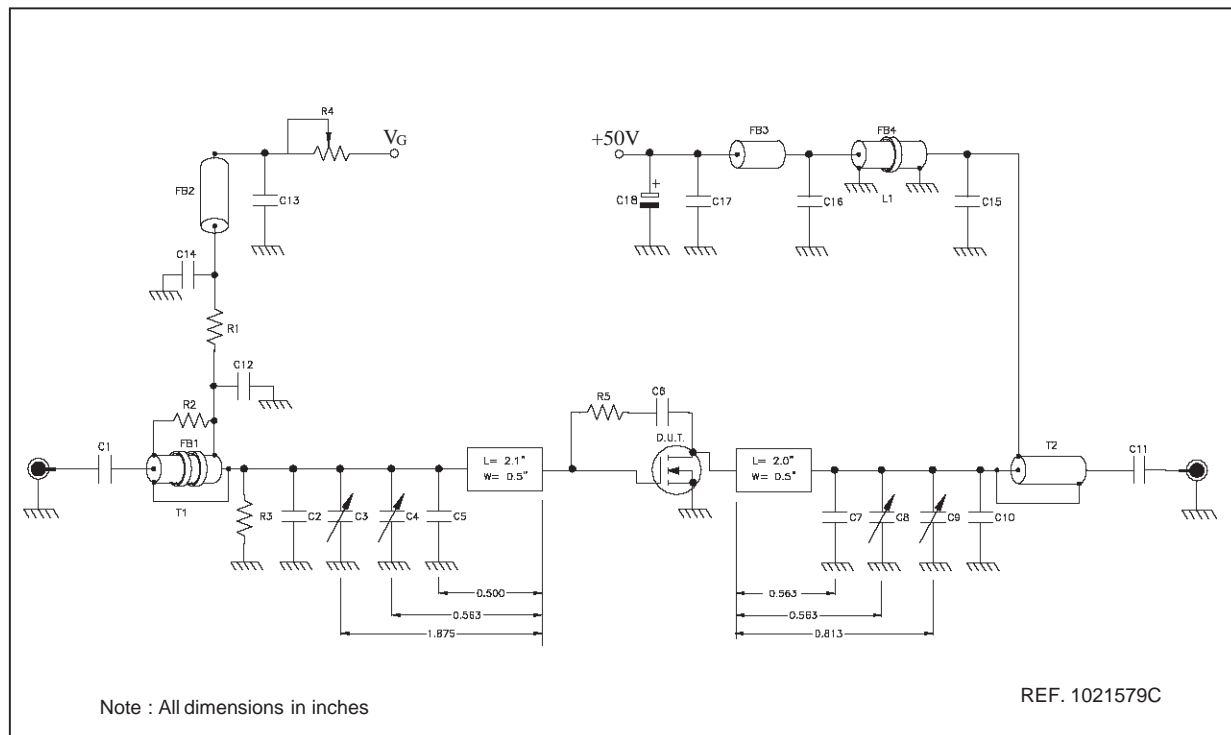

175 MHz Test Circuit Component Part List

| | | |
|------------|---|--------------------------------------|
| T1 | 4:1 Transformer, 25 ohm Flexible Coax .090 OD 6 " Long | |
| T2 | 1:4 Transformer, 25 ohm Semi-Rigid Coax .141 OD 6 " Long | |
| FB1 | Toroid X2, 0.5" OD .312" ID 850u 2 Turns | |
| FB2, FB3 | VK200 | |
| FB4 | Shield Bead, 1" OD 0.5" ID 850u 3 Turns | |
| L1 | 1/4Wave Choke, 50 ohm Semi-Rigid Coax .141 OD 12 " Long | |
| PCB | 0.062" Woven Fiberglass, 1 oz. Copper, 2 Sides, er = 2.55 | |
| R1, R3 | 470 ohm 1W Chip Resistor | R4 20K ohm 10 Turn Potentiometer |
| R2 | 360 ohm 1/2W Resistor | R5 560 ohm 1W Resistor |
| C1, C11 | 470 pF ATC Chip Cap | C7 30 pF ATC Chip Cap |
| C2 | 43 pF ATC Chip Cap | C10 91 pF ATC Chip Cap |
| C3, C8, C9 | Arco 404, 12-65 pF | C12, C15 1200 pF ATC Chip Cap |
| C4 | Arco 423, 16-100 pF | C13, C14 0.01 uF / 500V Chip Cap |
| C5 | 120 pF ATC Chip Cap | C16, C17 0.01 uF / 500V Chip Cap |
| C6 | 0.01 uF ATC Chip Cap | C18 10 uF 63V Electrolytic Capacitor |

175 MHz Test Circuit Photomaster

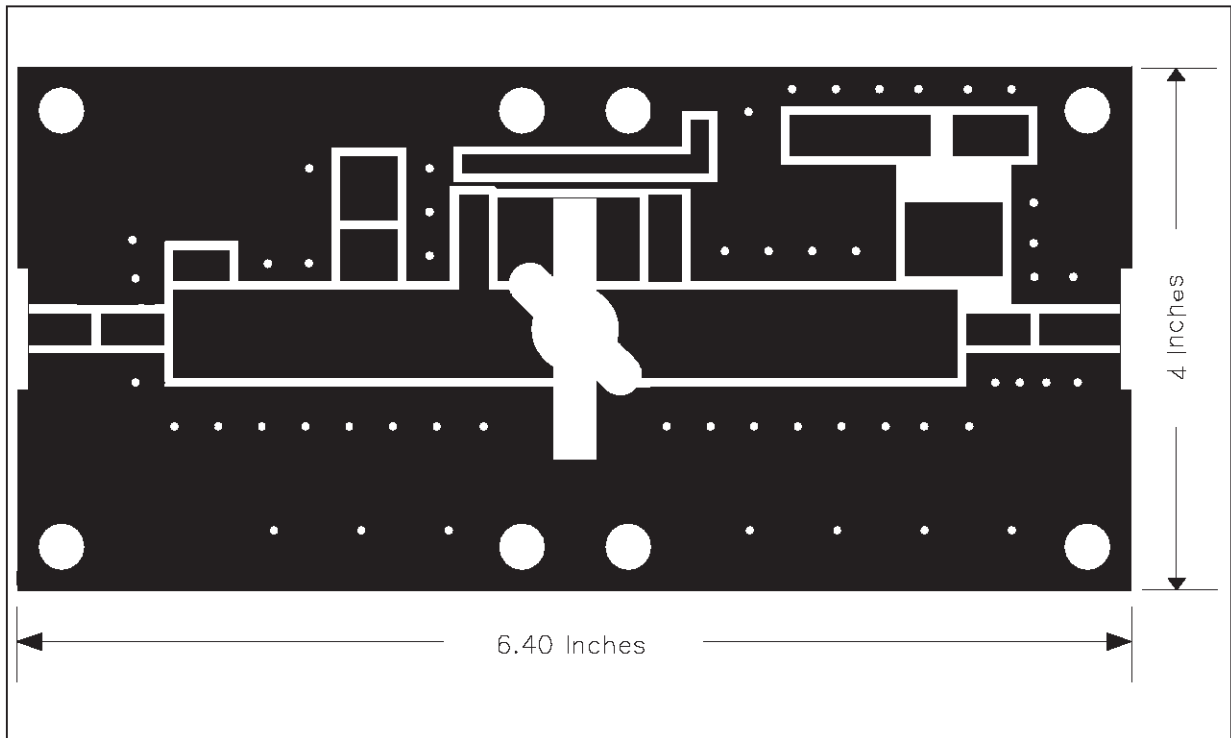

175 MHz Test Circuit

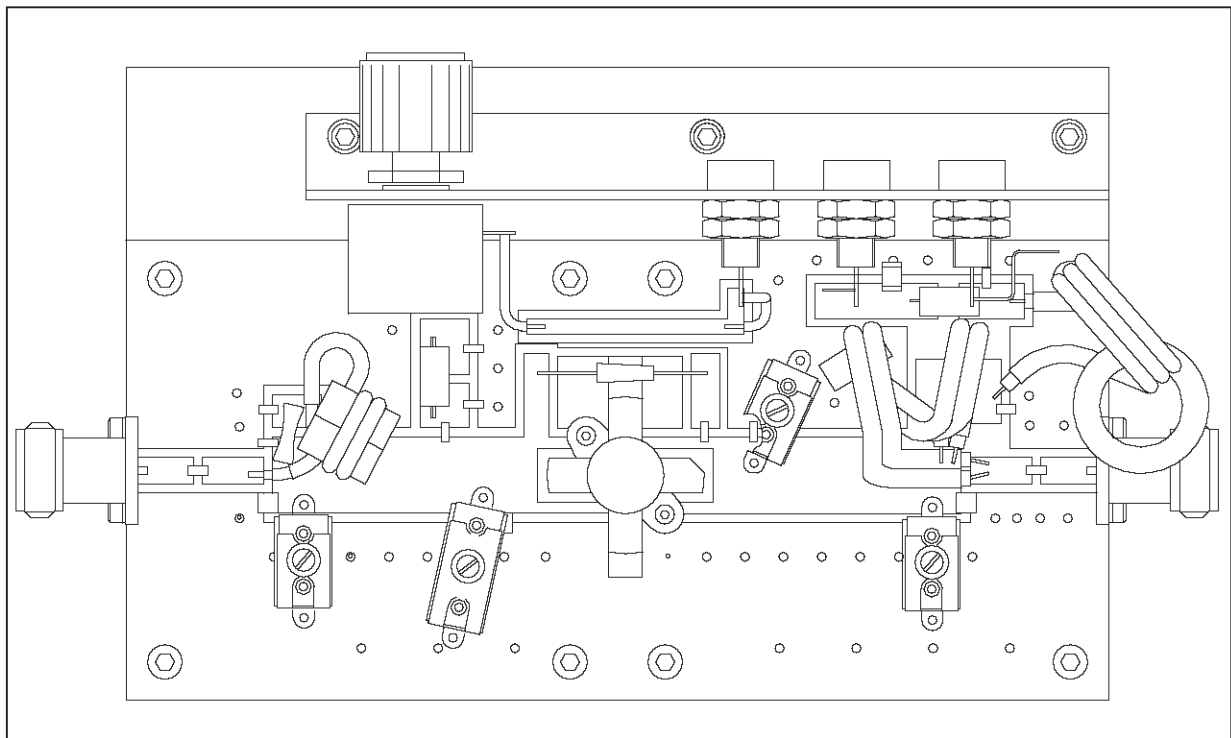

TYPICAL PERFORMANCE (30 MHz)

Output Power vs Input Power

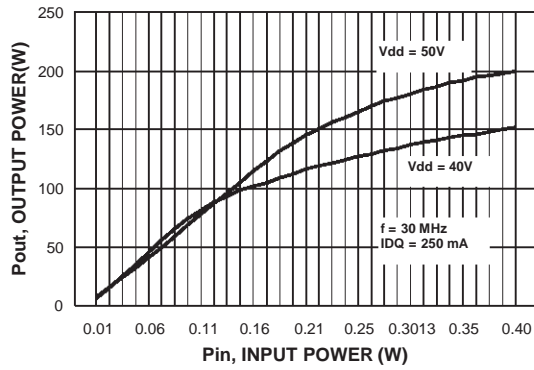

Power Gain vs Output Power

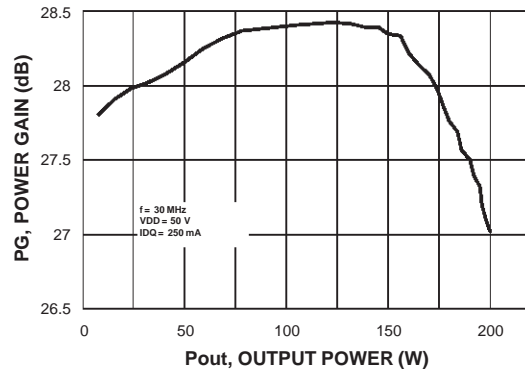

Efficiency vs Output Power

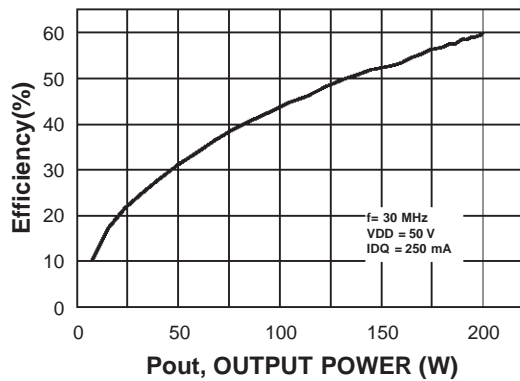

Output Power vs Supply Voltage

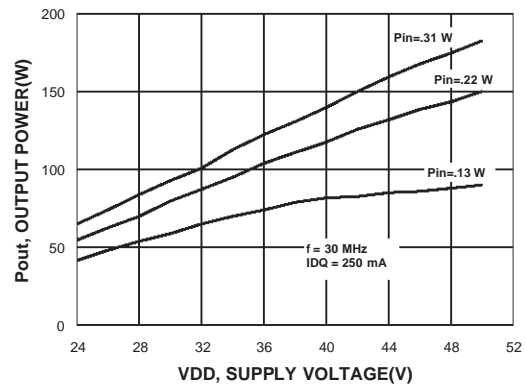

Output Power vs Gate Voltage

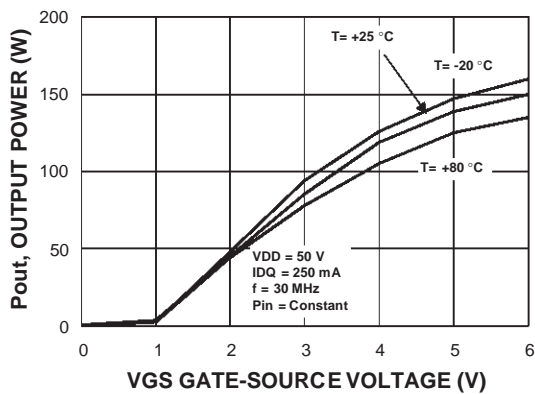

30 MHz Test Circuit Schematic (Engineering Test Circuit)

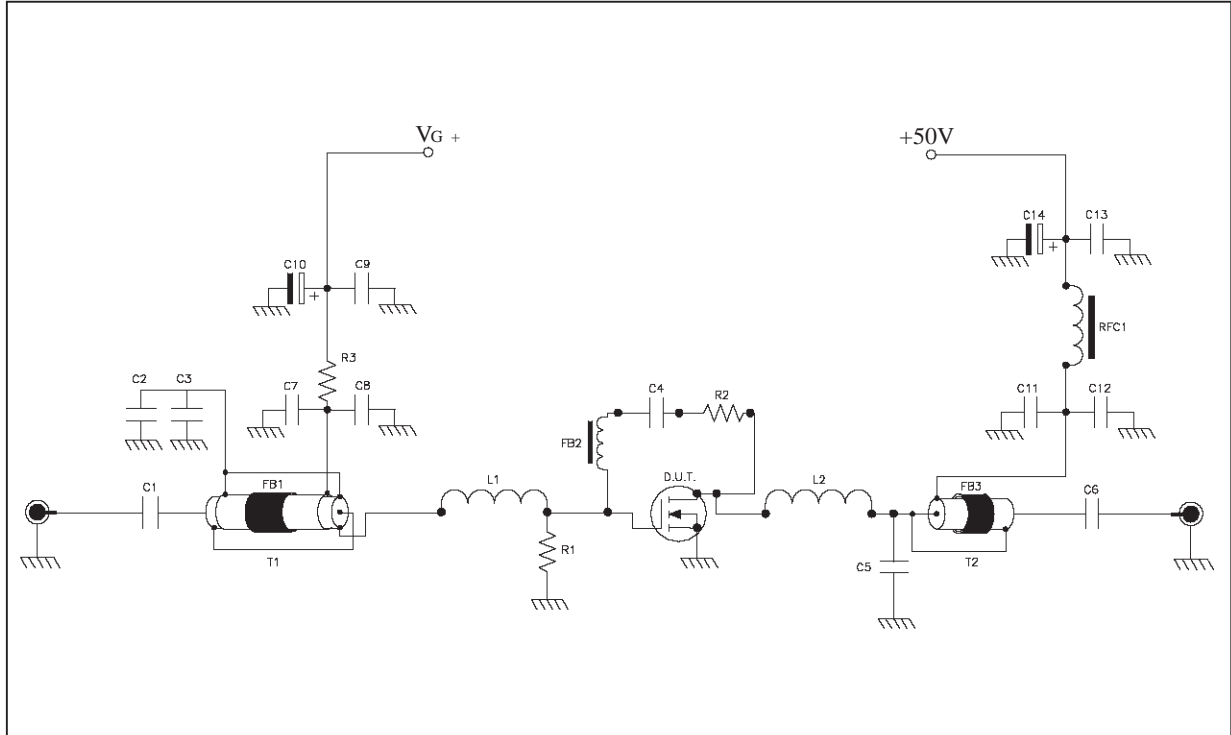

30 MHz Test Circuit Component Part List

| | | | |
|---------------------|--|-----|-----------------------------------|
| T1 | 9:1 Transformer, 25 ohm Flexible Coax with extra shield .090 OD 15" Long | | |
| T2 | 1:4 Transformer, 50 ohm Flexible Coax .225 OD 15" Long | | |
| FB1 | Toroid, 1.7" OD .30" ID 220u 4 Turns | | |
| FB2 | Surface Mount EMI Shield Bead | | |
| FB3 | Toroid, 1.7" OD .300" ID 220u 3 Turns | | |
| RFC1 | Toroid, 0.5" OD 0.30" ID, 125u 4 turns 12 awg wire | | |
| PCB | 0.062" Woven Fiberglass, 1 oz. Copper, 2 Sides, er = 2.55 | | |
| C1, C4, C6, C7, C8, | 0.01 uF ATC Chip Cap | C5 | 470 pF ATC Chip Cap |
| C9, C11, C12, C13 | 0.01 uF ATC Chip Cap | C10 | 10 uF 63V Electrolytic Capacitor |
| C2, C3 | 750 pF ATC Chip Cap | C14 | 100 uF 63V Electrolytic Capacitor |
| R1, R3 | 1K ohm 1W Chip Resistor | R2 | 680 ohm 3W Wirewound Resistor |

M174 (.500 DIA 4L N/HERM W/FLG) MECHANICAL DATA

| DIM. | mm | | | inch | | |
|------|-------|------|-------|-------|-------|-------|
| | MIN. | TYP. | MAX. | MIN. | TYP. | MAX. |
| A | 5.56 | | 5.84 | 0.219 | | 0.230 |
| B | | 3.18 | | | 0.125 | |
| C | 6.22 | | 6.48 | 0.245 | | 0.255 |
| D | 18.28 | | 18.54 | 0.720 | | 0.730 |
| E | | 3.18 | | | 0.125 | |
| F | 24.64 | | 24.89 | 0.970 | | 0.980 |
| G | 12.57 | | 12.83 | 0.495 | | 0.505 |
| H | 0.08 | | 0.18 | 0.003 | | 0.007 |
| I | 2.11 | | 3.00 | 0.083 | | 0.118 |
| J | 3.81 | | 4.45 | 0.150 | | 0.175 |
| K | | | 7.11 | | | 0.280 |
| L | 25.53 | | 26.67 | 1.005 | | 1.050 |
| M | 3.05 | | 3.30 | 0.120 | | 0.130 |

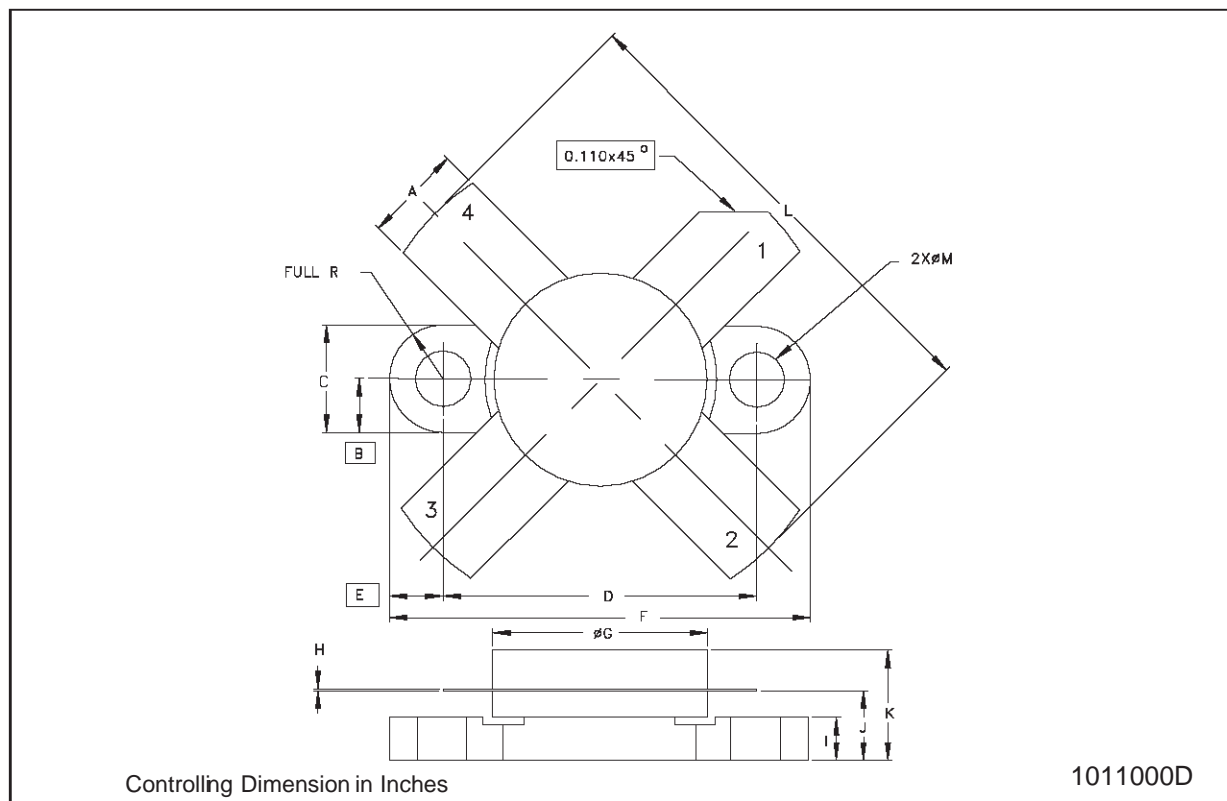

Information furnished is believed to be accurate and reliable. However, STMicroelectronics assumes no responsibility for the consequences of use of such information nor for any infringement of patents or other rights of third parties which may result from its use. No license is granted by implication or otherwise under any patent or patent rights of STMicroelectronics. Specification mentioned in this publication are subject to change without notice. This publication supersedes and replaces all information previously supplied. STMicroelectronics products are not authorized for use as critical components in life support devices or systems without express written approval of STMicroelectronics.

The ST logo is a trademark of STMicroelectronics

© 2000 STMicroelectronics – Printed in Italy – All Rights Reserved

STMicroelectronics GROUP OF COMPANIES

Australia - Brazil - China - Finland - France - Germany - Hong Kong - India - Italy - Japan - Malaysia - Malta - Morocco - Singapore - Spain - Sweden - Switzerland - United Kingdom - U.S.A.

<http://www.st.com>