



TSD4M451F
TSD4M451V

**SGS-THOMSON N-CHANNEL ENHANCEMENT MODE
ISOFET POWER MOS TRANSISTOR MODULE**

TYPE	V _{DSS}	R _{DS(on)}	I _D
TSD4M451F/V	450 V	0.1 Ω	45 A

- HIGH CURRENT POWER MOS MODULE
- VERY LOW R_{th} JUNCTION TO CASE
- DUAL SOURCE CONTACTS
- VERY LARGE SOA - LARGE PEAK POWER CAPABILITY
- ISOLATED CASE (2500V RMS)
- EASY TO MOUNT
- VERY LOW INTERNAL PARASITIC INDUCTANCE (TYPICALLY < 5 ns)
- AVALANCHE RUGGEDNESS TECHNOLOGY (SEE IRFP450 FOR RATING)

INDUSTRIAL APPLICATIONS:

- SMPS & UPS
- MOTOR CONTROL
- WELDING EQUIPMENT
- OUTPUT STAGE FOR PWM, ULTRASONIC CIRCUITS

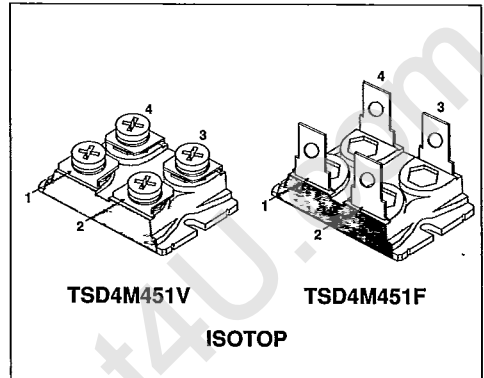

INTERNAL SCHEMATIC DIAGRAM

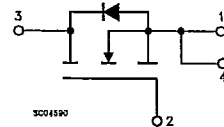

ABSOLUTE MAXIMUM RATINGS

Symbol	Parameter	Value	Unit
V _{DS}	Drain-Source Voltage (V _{GS} = 0)	450	V
V _{DGR}	Drain-Gate Voltage (R _{GS} = 20 kΩ)	450	V
V _{GS}	Gate-Source Voltage	± 20	V
I _D	Drain Current (continuous) at T _c = 25 °C	45	A
I _D	Drain Current (continuous) at T _c = 100 °C	28	A
I _{DM} (*)	Drain Current (pulsed)	180	A
P _{tot}	Total Dissipation at T _c = 25 °C	500	W
	Derating Factor	4	W/°C
T _{stg}	Storage Temperature	-55 to 150	°C
T _J	Max. Operating Junction Temperature	150	°C
V _{iso}	Insulation Withstand Voltage (AC-RMS)	2500	V

(*) Pulse width limited by safe operating area

THERMAL DATA S G S-THOMSON

$R_{thj-case}$	Thermal Resistance Junction-Case	Max	0.25	°C/W
R_{thc-h}	Thermal Resistance Case-Heatsink With Conductive Grease Applied	Max	0.05	°C/W

ELECTRICAL CHARACTERISTICS ($T_{case} = 25\text{ °C}$ unless otherwise specified)

OFF

Symbol	Parameter	Test Conditions	Min.	Typ.	Max.	Unit
$V_{(BR)DSS}$	Drain-Source Breakdown Voltage	$I_D = 1\text{ mA}$ $V_{GS} = 0$	450			V
I_{DSS}	Zero Gate Voltage Drain Current ($V_{GS} = 0$)	$V_{DS} = \text{Max Rating}$ $V_{DS} = \text{Max Rating} \times 0.8$ $T_C = 125\text{ °C}$			400 2	μA mA
I_{GSS}	Gate-Body Leakage Current ($V_{DS} = 0$)	$V_{GS} = \pm 20\text{ V}$			± 500	nA

ON (*)

Symbol	Parameter	Test Conditions	Min.	Typ.	Max.	Unit
$V_{GS(th)}$	Gate Threshold Voltage	$V_{DS} = V_{GS}$ $I_D = 1\text{ mA}$	2		4	V
$R_{DS(on)}$	Static Drain-Source On Resistance	$V_{GS} = 10\text{ V}$ $I_D = 28\text{ A}$			0.1	Ω

DYNAMIC

Symbol	Parameter	Test Conditions	Min.	Typ.	Max.	Unit
g_{fs}	Forward Transconductance	$V_{DS} = 25\text{ V}$ $I_D = 28\text{ A}$	28			mho
C_{iss}	Input Capacitance	$V_{DS} = 25\text{ V}$ $f = 1\text{ MHz}$ $V_{GS} = 0$			12000	pF
C_{oss}	Output Capacitance				2400	pF
C_{rss}	Reverse Transfer Capacitance				1000	pF

SWITCHING (INDUCTIVE LOAD)

Symbol	Parameter	Test Conditions	Min.	Typ.	Max.	Unit
$t_{d(on)}$	Turn-on Time	$V_{DD} = 225\text{ V}$ $I_D = 28\text{ A}$ $R_{GS} = 25\text{ }\Omega$ $V_{GS} = 10\text{ V}$			180	ns
$(di/dt)_{on}$	Turn-on Current Slope				150	A/ μs
$t_{d(off)}$	Turn-off Delay Time				3000	ns
t_f	Fall Time				300	ns

SOURCE DRAIN DIODE

Symbol	Parameter	Test Conditions	Min.	Typ.	Max.	Unit
I_{SD}	Source-Drain Current				45	A
$I_{SDM(*)}$	Source-Drain Current (pulsed)				180	A
V_{SD}	Forward On Voltage	$I_{SD} = 45\text{ A}$ $V_{GS} = 0$			1.4	V
t_{rr}	Reverse Recovery Time	$I_{SD} = 45\text{ A}$ $di/dt = 100\text{ A}/\mu\text{s}$		1300		ns

(*) Pulsed: Pulse duration = 300 μs , duty cycle 1.5 %

(*) Pulse width limited by safe operating area

SGS-THOMSON

T-39-15

Safe Operating Areas

Thermal Impedance

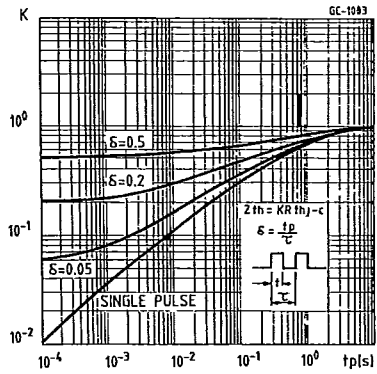
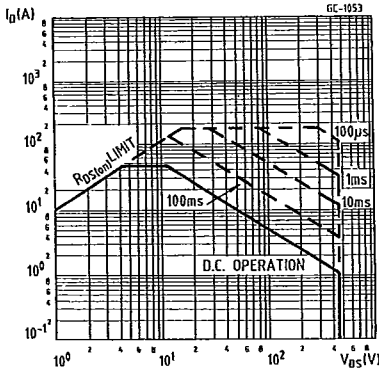

Derating Curve

Output Characteristics

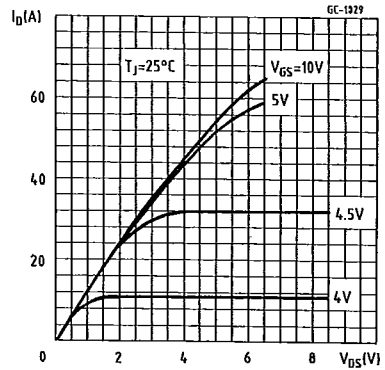
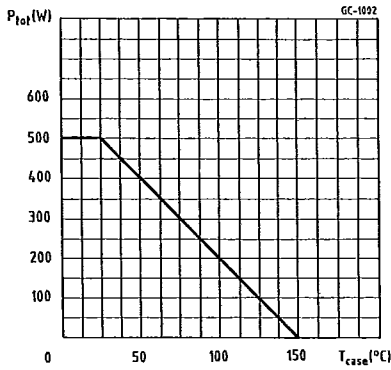

Transfer Characteristics

Transconductance

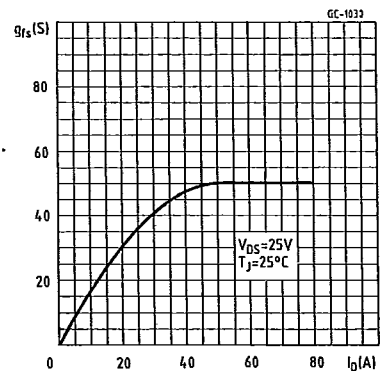
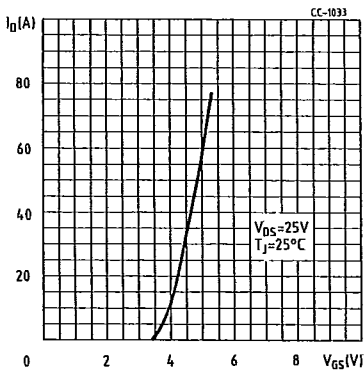

3OE D 7929237 0030583 9

Static Drain-Source On Resistance

Gate Charge vs Gate-source Voltage

SGS-THOMSON

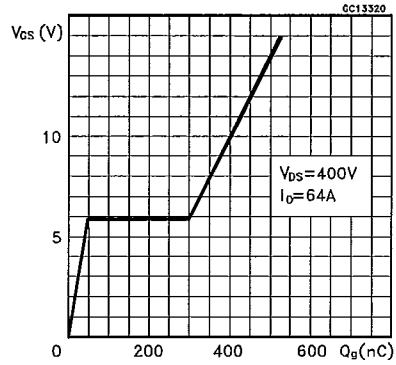
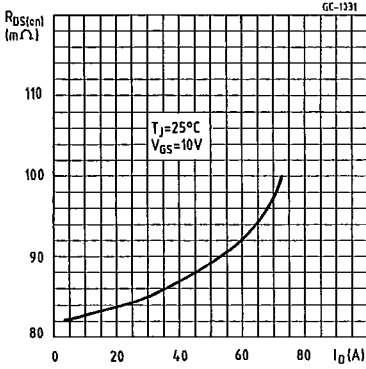

Capacitance Variation

Normalized Gate Threshold Voltage vs Temperature

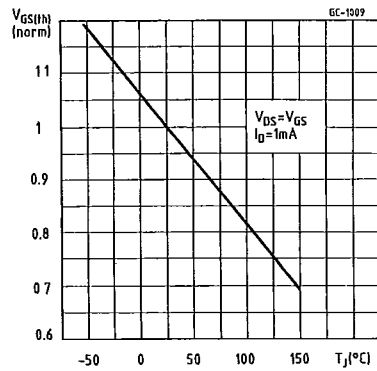
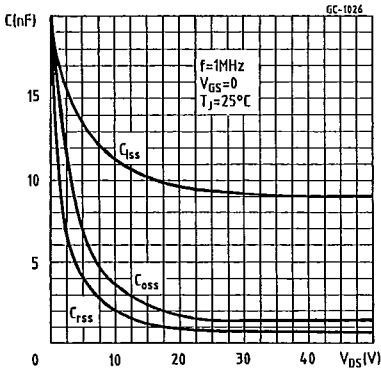

Normalized Breakdown Voltage vs Temperature

Normalized On Resistance vs Temperature

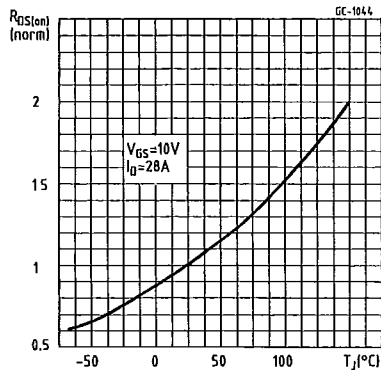
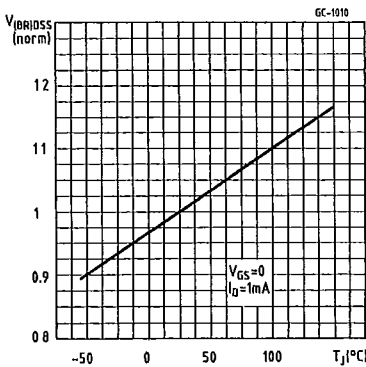

Source-Drain Diode Forward Characteristics

Gate Charge Test Circuit

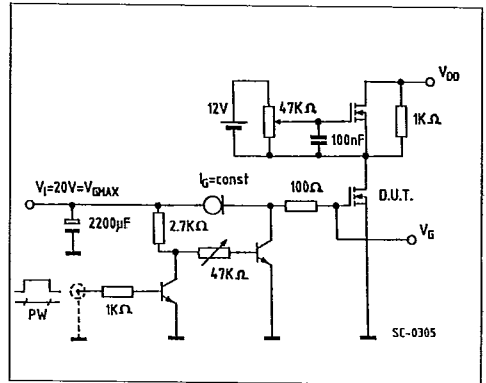
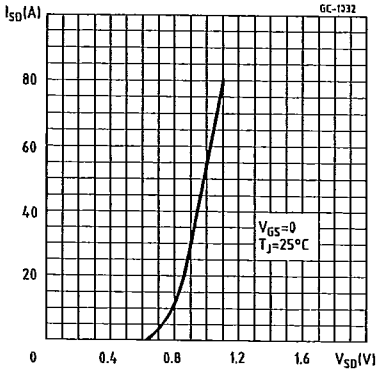

Test Circuit For Inductive Load Switching and Diode Reverse Recovery Times

Diode Reverse Recovery Time Waveform

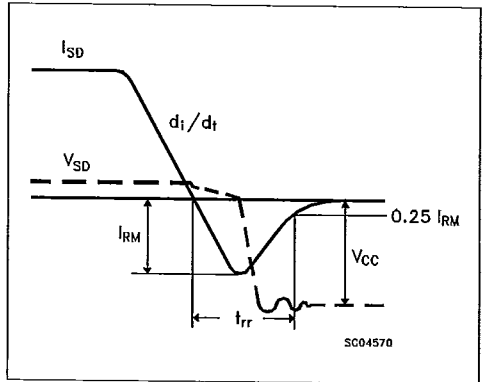
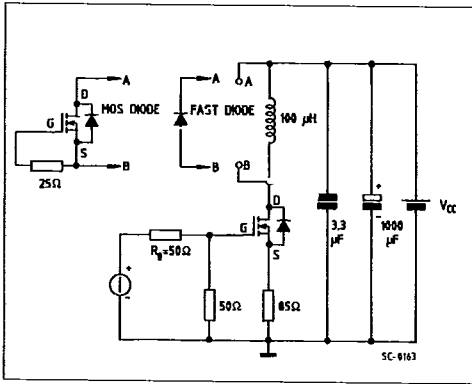

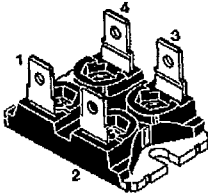

ISOTOP
Fast-on version
sales types with the suffix F

MECHANICAL DATA

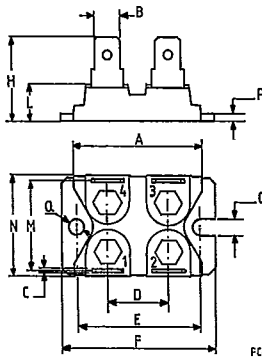

FC-9309

	DIMENSIONS			
	mm		Inches	
	min.	max	min.	max
A	31.5	31.7	1.240	1.248
B	6.2	6.4	0.244	0.252
C	0.75	0.85	0.029	0.033
D	14.9	15.1	0.586	0.590
E	30.1	30.3	1.185	1.193
F	38	38.2	1.496	1.503
G	4	-	0.157	-
H	20.3	20.7	0.799	0.815
L	8.9	9.1	0.350	0.358
M	22.4	23	0.881	0.905
N	25.2	25.4	0.992	1.000
P	1.95	2.05	0.076	0.080
Q	4	-	0.157	-

PIN CONNECTIONS

MOSFET

pin 1: Source pin 2: Gate
pin 3: Drain pin 4: Source sensings

DARLINGTON

pin 1: Emitter pin 2: Base1
pin 3: Collector pin 4: Base 2

TRANSISTOR

pin 1: Emitter pin 2: Base
pin 3: Collector pin 4: Emitter sensing

Torque: Mounting $1.3 \pm 0.2 \text{ N} \cdot \text{m}$ (max)

Weight: Package 25.5 g

Note: The mechanical data are the same for the 3 pin version (4th pin missing)

S G S-THOMSON

T-91-20

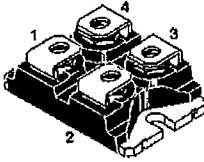

ISOTOP
Screw version
sales types with the suffix V

MECHANICAL DATA

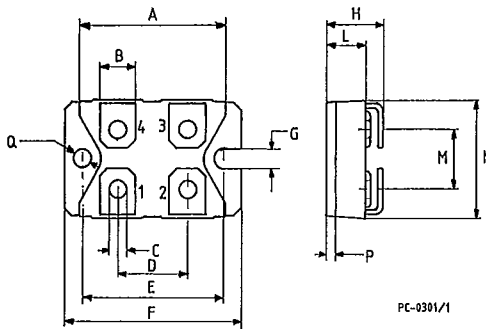

	DIMENSIONS			
	mm		Inches	
	min.	max	min.	max
A	31.5	31.7	1.240	1.248
B	7.8	8.2	0.307	0.322
C	4.1	4.3	0.161	0.169
D	14.9	15.1	0.586	0.590
E	30.1	30.3	1.185	1.193
F	38	38.2	1.496	1.503
G	4	-	0.157	-
H	11.8	12.2	0.464	0.480
L	8.9	9.1	0.350	0.358
M	12.6	12.8	0.496	0.503
N	25.2	25.4	0.992	1.000
P	1.95	2.05	0.076	0.080
Q	4	-	0.157	-

PIN CONNECTIONS

MOSFET

pin 1: Source pin 2: Gate
pin 3: Drain pin 4: Source sensings

DARLINGTON

pin 1: Emitter pin 2: Base1
pin 3: Collector pin 4: Base 2

TRANSISTOR

pin 1: Emitter pin 2: Base
pin 3: Collector pin 4: Emitter sensing

Torque: Terminal $1.3 \pm 0.2 \text{ N} \cdot \text{m}$ (max)
Mounting $1.3 \pm 0.2 \text{ N} \cdot \text{m}$ (max)

Weight: Package 29 g
4 Screws: 7,5 g

Note: The mechanical data are the same for the 3 pin version
(4th pin missing)

SGS-THOMSON

T-91-20

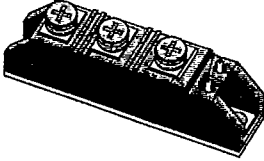

TRANSPACK (TO-240)

MECHANICAL DATA

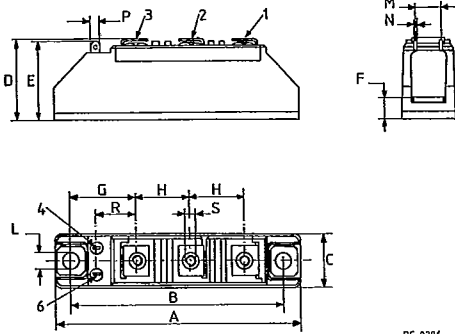

PC-0236

	DIMENSIONS			
	mm		Inches	
	min.	max	min.	max
A	91.5	92.5	3.602	3.641
B	79.75	80.25	3.140	3.160
C	19.5	20.55	0.767	0.809
D	29.00	31.00	1.141	1.220
E	28.8	30	1.134	1.181
F	8.5 typ.		0.334 typ.	
G	24.4 typ.		0.960 typ.	
H	19.5	20.5	0.767	0.807
L	6.2 typ.		0.244 typ.	
M	8.95	11.05	0.352	0.435
N	0.78	0.84	0.030	0.033
P	2.72	2.87	0.107	0.113
R	14	-	0.551	-
S	M5			

Torque: Terminal $2.2 \pm 0.5 \text{ N} \cdot \text{m}$ (max)
 Mounting $3.5 \pm 0.5 \text{ N} \cdot \text{m}$ (max)

Weight: Package 110 g
 Accessory 21 g

Note: The mechanical data are the same for the 2 power pin version (either pin 1 or pin 2 missing)