



# TSH511

## HiFi stereo/mono infrared receiver Stereo sub-carrier demodulator

- Supply voltage: **2.3V to 5.5V**
- Carriers frequency range: **0.4 to 11 MHz**
- Two FM receivers for stereo
- Integrated audio buffers
- Audio outputs: 20 mW into 16 ohms
- **High sensitivity: 4µV @12dB SINAD**
- Flexibility: access pins for each section
- Receiver 2 Standby for mono operation

### DESCRIPTION

The TSH511 is a 0.4 to 11 MHz dual FM receiver. This circuit offers the functions needed for a highly sensitive infrared HiFi STEREO receiver.

Featuring high input sensitivity and high input dynamic range, each receiver integrates a RF front-end LNA, an intermediate amplifier with 2 external filters, a voltage limiter, a quadrature FM demodulator, and finally an audio buffer.

The integrated audio buffers are able to drive directly a 16 ohms headphone with 20mW.

A SQUELCH circuit mutes both audio amplifiers. Access pins to each section makes the TSH511 suited for a wide field of applications.

For MONO applications, the STANDBY pin enables one receiver only, reducing the supply current.

The TSH511 forms a chipset with the dual transmitter TSH512.

### APPLICATIONS

- Infrared HiFi stereo receiver
- Infrared Multimedia Headsets
- Stereo sub-carrier demodulator
- FM IF receiver systems
- Power Line Carrier Intercoms

### ORDER CODE

Part Number	Temperature Range	Package	Conditioning	Marking
TSH511CF	-40°C to +85°C	TQFP44	Tray	TSH511C
TSH511CFT	-40°C to +85°C	TQFP44	Tape & reel	TSH511C

### PACKAGE

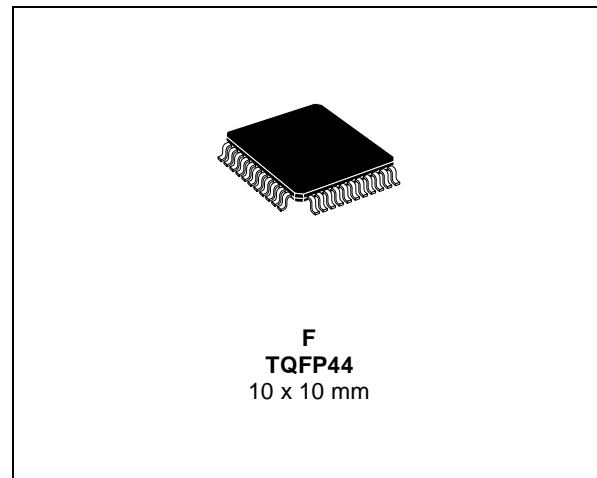

### PIN CONNECTION (top view)

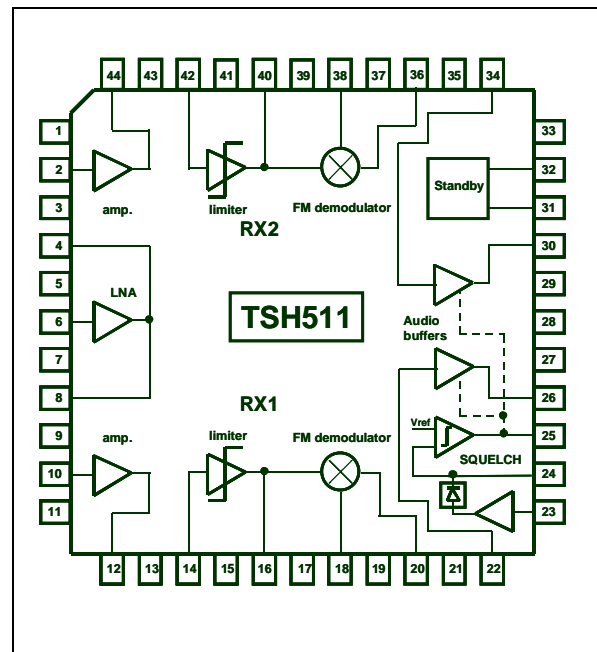

**ABSOLUTE MAXIMUM RATINGS**

Symbol	Parameter	Value	Unit
Vcc	Supply voltage <sup>1)</sup>	7	V
Toper	Operating free air temperature range	-40 to +85	°C
Tstg	Storage temperature	-65 to +150	°C
Tj	Maximum junction temperature	150	°C
Rthjc	Thermal resistance junction to case	14	°C/W
ESD except for pin 6	HBM: Human Body Model <sup>2)</sup>	2	kV
	CDM: Charged Device Model <sup>3)</sup>	1.5	
	MM: Machine Model <sup>4)</sup>	0.2	
ESD only for pin 6	HBM: Human Body Model	1	kV
	CDM: Charged Device Model	1	
	MM: Machine Model	0.1	
Latch-up	Class <sup>5)</sup>	A	

1. All voltages values, except differential voltage, are with respect to network ground terminal
2. ElectroStatic Discharge pulse (ESD pulse) simulating a human body discharge of 100 pF through 1.5kΩ
3. Discharge to Ground of a device that has been previously charged.
4. ElectroStatic Discharge pulse (ESD pulse) approximating a pulse of a machine or mechanical equipment.
5. Corporate ST Microelectronics procedure number 0018695

**OPERATING CONDITIONS**

Symbol	Parameter	Value	Unit
Vcc	Supply voltage	2.3 to 5.5	V
f <sub>audio</sub>	Audio frequency range	20 to 20,000	Hz
f <sub>carrier</sub>	Carrier frequency range	0.4 to 11	MHz

**BLOC DIAGRAM**

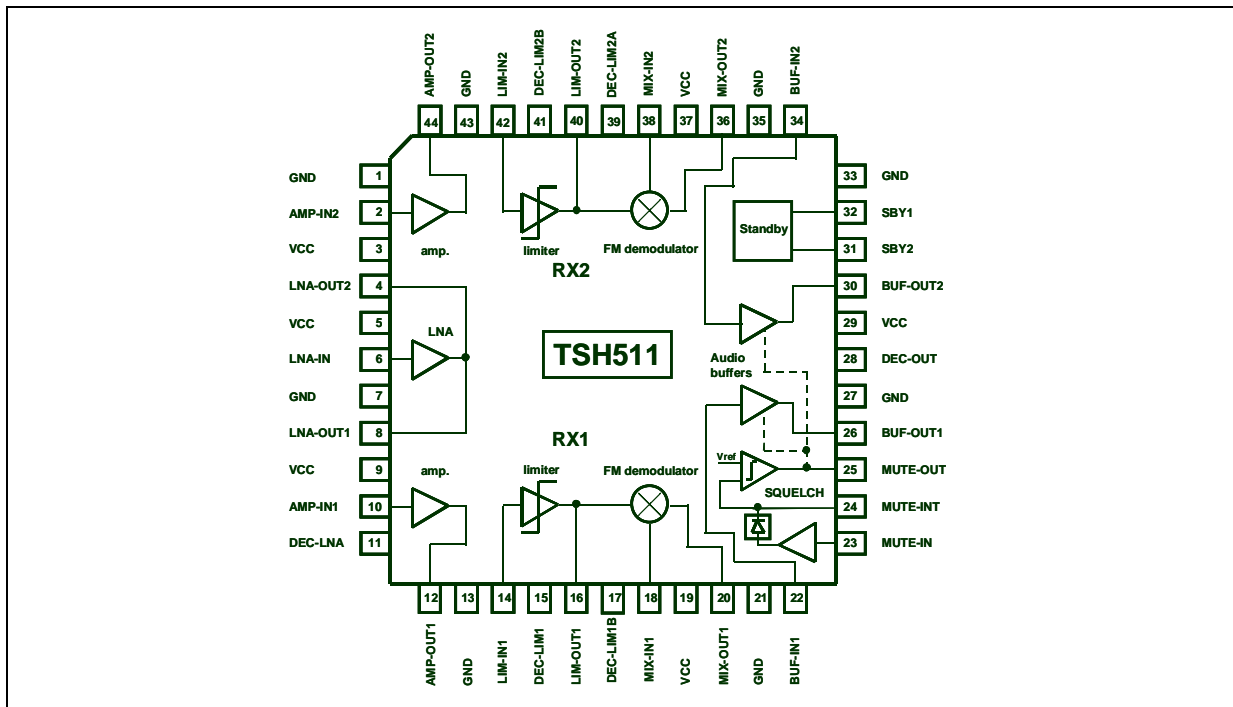

## PIN DESCRIPTION

Pin	Pin name	related to	direction <sup>1)</sup>	Pin description
1	GND	-	-	GROUND
2	AMP-IN2	RX2	I	Intermediate amplifier input
3	VCC	-	-	SUPPLY VOLTAGE
4	LNA-OUT2	RX2	O	Low Noise Amplifier output
5	VCC	-	-	SUPPLY VOLTAGE
6	LNA-IN	RX1 & RX2	I	Low Noise Amplifier input
7	GND	-	-	GROUND
8	LNA-OUT1	RX1	O	Low Noise Amplifier output
9	VCC	-	-	SUPPLY VOLTAGE
10	AMP-IN1	RX1	I	Intermediate amplifier input
11	DEC-LNA	RX1 & RX2	-	Decoupling capacitor
12	AMP-OUT1	RX1	O	Intermediate amplifier input
13	GND	-	-	GROUND
14	LIM-IN1	RX1	I	Limiter input
15	DEC-LIM1A	RX1	-	Decoupling capacitor
16	LIM-OUT1	RX1	O	Limiter output
17	DEC-LIM1B	RX1	-	Decoupling capacitor
18	MIX-IN1	RX1	I	Mixer input
19	VCC	-	-	SUPPLY VOLTAGE
20	MIX-OUT1	RX1	O	Mixer output (demodulated audio signal)
21	GND	-	-	GROUND
22	BUF-IN1	RX1	I	Audio buffer input
23	MUTE-IN	RX1 & RX2	I	Noise amplifier input (Squelch circuit)
24	MUTE-INT	RX1 & RX2	-	Capacitor connection of the noise rectifier
25	MUTE-OUT	RX1 & RX2	O	Capacitor connection (ramp generator to mute the audio)
26	BUF-OUT1	RX1	O	Audio buffer output
27	GND	-	-	GROUND
28	DEC-OUT	RX1 & RX2	-	Decoupling capacitor of Audio buffers
29	VCC	-	-	SUPPLY VOLTAGE
30	BUF-OUT2	RX2	O	Audio buffer output
31	SBY2	RX1 & RX2	I	Standby 2
32	SBY1	RX1 & RX2	I	Standby 1
33	GND	-	-	GROUND
34	BUF-IN2	RX2	I	Audio buffer input
35	GND	-	-	GROUND
36	MIX-OUT2	RX2	O	Mixer output
37	VCC	-	-	SUPPLY VOLTAGE
38	MIX-IN2	RX2	I	Mixer input
39	DEC-LIM2A	RX2	-	Decoupling capacitor
40	LIM-OUT2	RX2	O	Limiter output
41	DEC-LIM2B	RX2	-	Decoupling capacitor
42	LIM-IN2	RX2	I	Limiter input
43	GND	-	-	GROUND
44	AMP-OUT2	RX2	O	Intermediate amplifier output

1. pin direction: I = input pin, O = output pin, - = pin to connect to supply or decoupling capacitors or external components

TYPICAL SCHEMATIC

Stereo infrared receiver

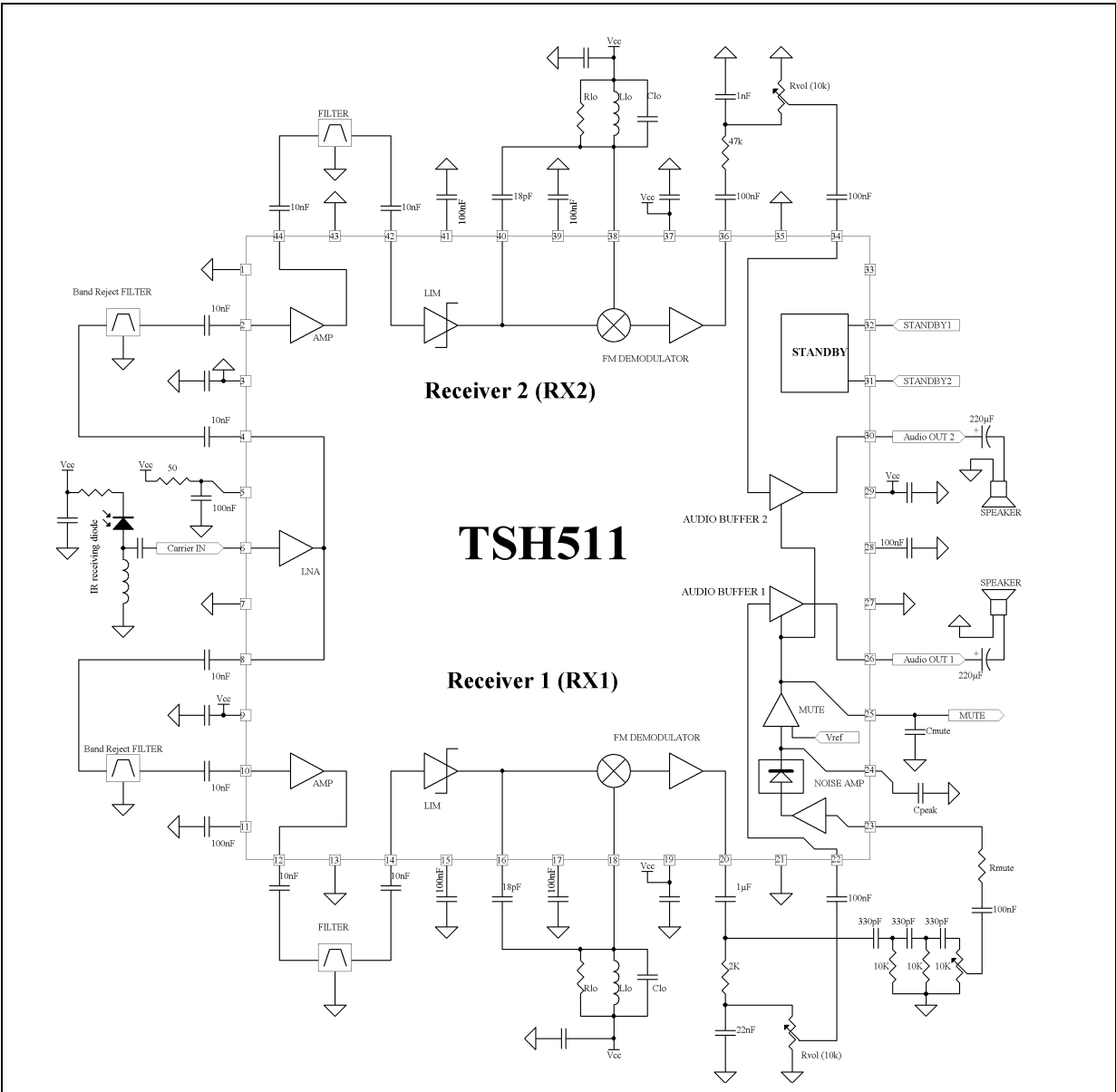

### INFRARED STEREO HEADPHONE APPLICATION

The right side of the figure shows the block-diagram of an infrared stereo receiver using the TSH511. The sensitive LNA directly connected to the photodiode does not require an external pre-amplifier. After filtering, the amplified signals are limited and demodulated with quadrature demodulators. The two integrated audio buffers directly drive the stereo headphones. The audio power reaches 2x20mW in two 16Ω loads. The built-in squelch function fades-out the audio when the incoming infrared signal is low. The standby inputs SBY1 and SBY2 enable only one receiver for the mono applications.

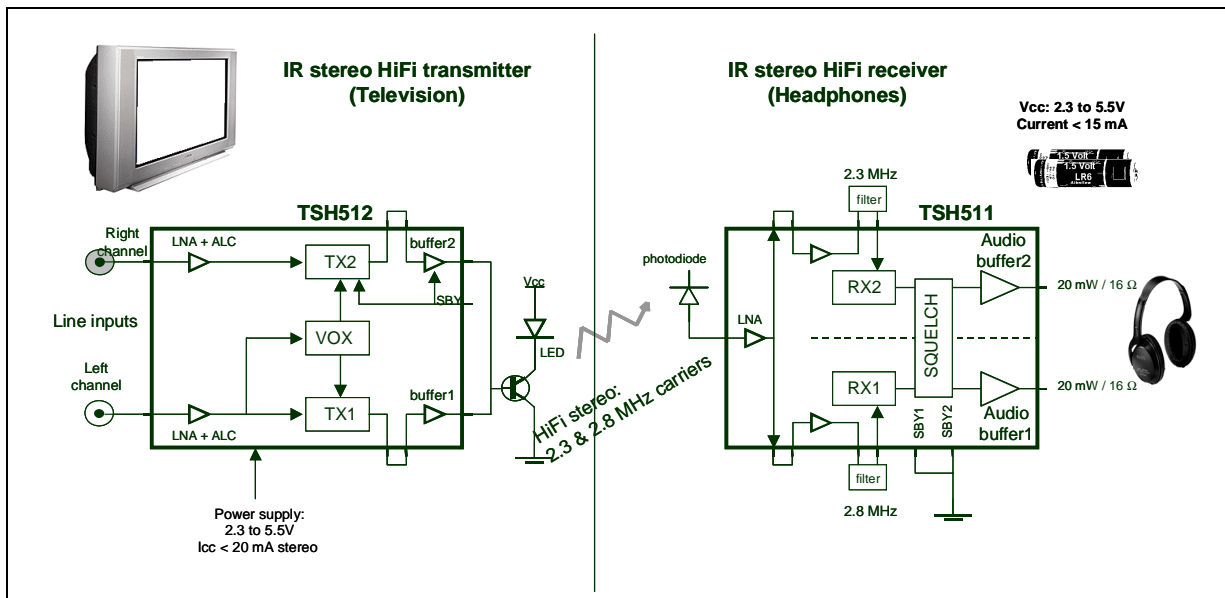

**MULTIMEDIA APPLICATION: HEADSET SIDE**

The TSH511 receives the HiFi stereo sound from the computer through 2.3 and 2.8 MHz stereo infrared carriers. The access pins to the RF amplifiers allow the use of a 1.7 MHz reject filter to cancel the transmitted signal of the microphone. The wide supply range (2.3 to 5.5 V) allows battery operation.

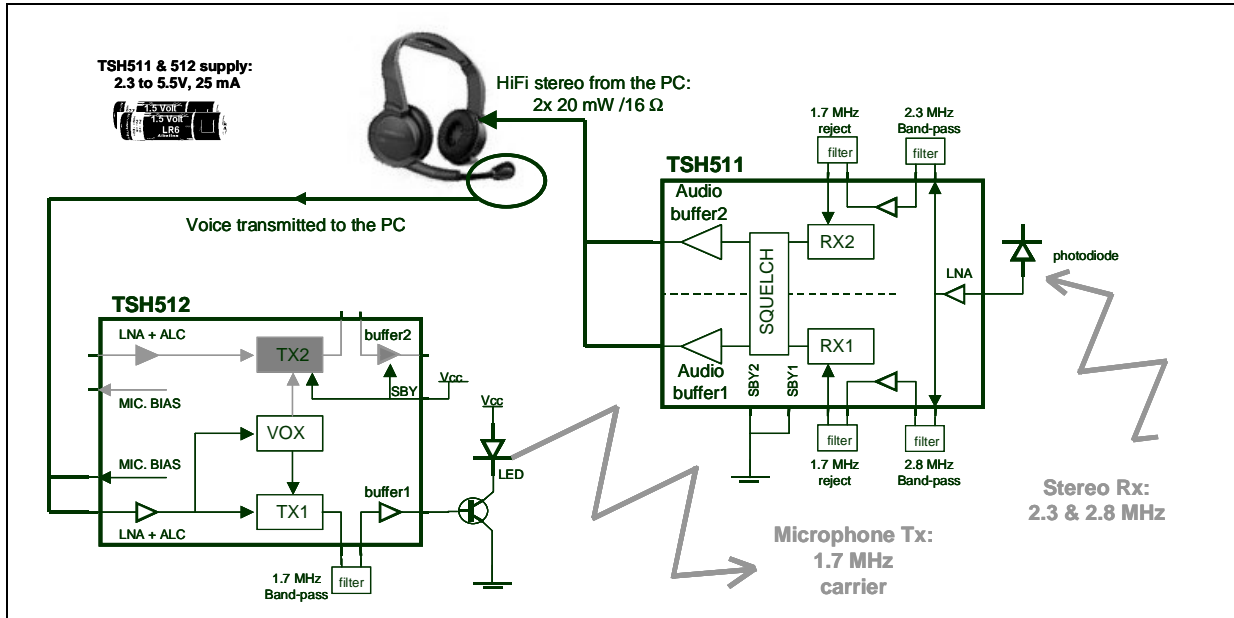

**MULTIMEDIA APPLICATION: COMPUTER SIDE**

In multimedia application, the TSH511 receives the voice of the user through the 1.7 MHz infrared carrier. The standby pins can disable the unused receiver and audio amplifier to reduce the supply current.

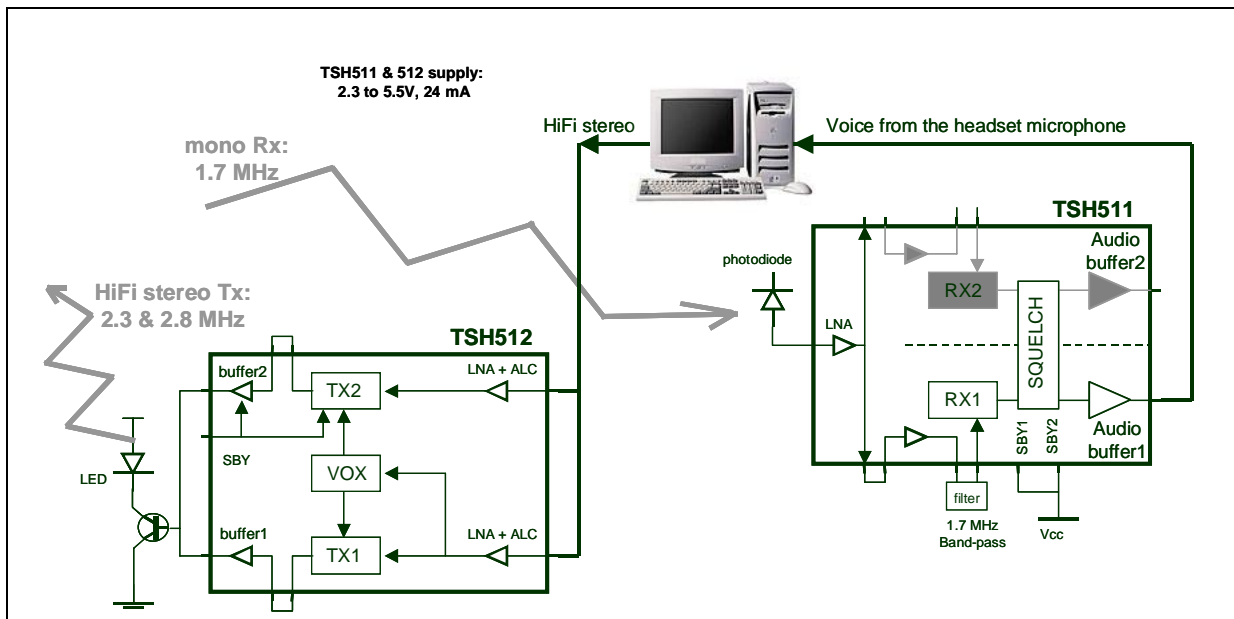

**ELECTRICAL CHARACTERISTICS**

$V_{CC} = 2.7V$ ,  $T_{amb} = 25^{\circ}C$ ,  $f_{audio} = 1\text{ kHz}$ ,  $f_{carrier} = 2.8\text{ MHz}$ , frequency deviation =  $\pm 75\text{ kHz}$  (unless otherwise specified)

Symbol	Parameter	Test condition	Min	Typ	Max	Unit
<b>Overall Circuit (referring to typical application schematic, without reject filters)</b>						
$I_{CC\_OX}$	Current consumption, RX1 is on, RX2 is on.	SBY1 = 'Low', SBY2 = X (X = don't care)		15	18	mA
$I_{CC\_10}$	Current consumption RX1 is on, RX2 is off RX1 audio buffer is on RX2 audio buffer is on	SBY1 = 'High', SBY2 = 'Low'		11	13	mA
$I_{CC\_11}$	Current consumption RX1 is on, RX2 is off RX1 audio buffer is on, RX2 audio buffer is off	SBY1 = 'High', SBY2 = 'High'		9.5	11.5	mA
MAUS	Maximum Usable Average Sensitivity	with audio SINAD=12 dB, audio BW=30 kHz with audio SINAD=26 dB, audio BW=30 kHz		4 19		$\mu V_{RMS}$
$SN_{OUT}$	Output audio signal to noise ratio	$V_{carrier} = 1\text{ mV}_{RMS}$ , with psophometric filter		58		dB
$V_i$	Input limiting voltage	output S/N reduced by 3dB, in BW = 30kHz output S/N reduced by 3dB, psophometric filter		80 60		$\mu V_{RMS}$
THD	Total Harmonic Distortion	$V_{carrier} = 1\text{ mV}_{RMS}$ , with psophometric filter		0.6		%
<b>Low Noise Amplifier (LNA) Section</b>						
$G_{LNA}$	LNA voltage gain	$Z_L = 2\text{ k}\Omega$ , $f_{carrier} = 10\text{ MHz}$	18	22	28	dB
$BW_{LNA}$	-3dB LNA Bandwidth	$Z_L = 2\text{ k}\Omega$		20		MHz
$E_{n\_LNA}$	Equivalent input noise voltage	$R_s = 0\ \Omega$		3.4		$nV/\sqrt{Hz}$
$I_{n\_LNA}$	Equivalent input noise current	$R_s = 0\ \Omega$		0.6		$pA/\sqrt{Hz}$
$Z_{LNA\_IN}$	Input impedance defined as $R_{LNA\_IN}$ in parallel with $C_{LNA\_IN}$	$R_{LNA\_IN}$ $C_{LNA\_IN}$		30 2		$k\Omega$ $pF$
$Z_{LNA\_OUT}$	Output impedance			200		$\Omega$
$P_{1dB\_LNA}$	1dB compression point	$Z_L = 2\text{ k}\Omega$ $Z_L = 2\text{ k}\Omega$ , $f_{carrier}=10\text{ MHz}$		127 95		$mV_{RMS}$
$IIP3_{LNA}$	Input 3rd order interception point	$Z_L = 2\text{ k}\Omega$ $Z_L = 2\text{ k}\Omega$ , $f_{carrier}=10\text{ MHz}$		30 22		$mV_{RMS}$

Symbol	Parameter	Test condition	Min	Typ	Max	Unit
<b>Amplifier (AMP) Section</b>						
$G_{AMP}$	Amplifier Voltage Gain	$Z_L=2\text{ k}\Omega$ , $f_{carrier}=10\text{ MHz}$	16	20		dB
$Z_{AMP\_IN}$	Input impedance defined as $R_{AMP\_IN}$ in parallel with $C_{AMP\_IN}$	$R_{AMP\_IN}$ $C_{AMP\_IN}$		10 2		$\text{k}\Omega$ $\text{pF}$
$Z_{AMP\_OUT}$	Output impedance			350		$\Omega$
$P_{1dBAMP}$	1dB compression point	$Z_L = 2\text{ k}\Omega$ $Z_L = 2\text{ k}\Omega$ , $f_{carrier}=10\text{ MHz}$	220	560 380		$\text{mV}_{RMS}$
$BW_{AMP}$	-3dB AMP Bandwidth	$Z_L = 2\text{ k}\Omega$		11		MHz
<b>Limiter (LIM) Section</b>						
$G_{LIM}$	Voltage gain	$Z_L=15\text{k}\Omega$ tied to GND	50	54	60	dB
$Z_{LIM\_IN}$	Input impedance defined as $R_{LIM\_IN}$ in parallel with $C_{LIM\_IN}$	$R_{LIM\_IN}$ $C_{LIM\_IN}$		15 2		$\text{k}\Omega$ $\text{pF}$
$V_{LIM\_OUT}$	Output Voltage	$Z_L = 15\text{ k}\Omega$ tied to GND		170		$\text{mV}_{pp}$
<b>FM Demodulator Section</b>						
$V_{DEM}$	Output voltage	+75 kHz FM deviation typical application schematic $Z_L = 4\text{ k}\Omega$	700	800	900	$\text{mV}_{RMS}$
$Z_{DEM\_OUT}$	Output impedance			100		$\Omega$
<b>Squelch Section</b>						
ATT	Audio attenuation on each receiver when audio buffers are muted.	RX1 and RX2 audio buffers muted $Z_L = 16\text{ }\Omega$ on both audio buffers	55	65		dB
$Z_{N\_IN}$	Noise Amplifier Input impedance			2		$\text{k}\Omega$
$V_{N\_TH}$	Comparator threshold	from MUTED to UNMUTED state, $R_{MUTE} = 22\text{ k}\Omega$ , $f_{IN} = 100\text{ kHz}$		9		$\text{mV}_{RMS}$
$V_{N\_HYS}$	Comparator hysteresis	$R_{MUTE} = 22\text{ k}\Omega$ , $f_{IN} = 100\text{ kHz}$		1		$\text{mV}_{RMS}$
$I_{MUTE\_SINK}$	Current sunk on pin 25 to discharge $C_{MUTE}$ capacitor: ramp generator controlling the attenuation from ON to OFF states of audio buffers.	Voltage on pin 25 = 1.7V		24		$\mu\text{A}$
$I_{MUTE\_SOURCE}$	Current sourced on pin 25 to charge $C_{MUTE}$ capacitor: ramp generator controlling the attenuation from OFF to ON states of audio buffers.	Voltage on pin 25 = 1.7V		14		$\mu\text{A}$



Symbol	Parameter	Test condition	Min	Typ	Max	Unit
<b>Audio Buffers</b>						
Z <sub>OD-IN</sub>	Input Impedance			200		kΩ
BW <sub>1dB</sub>	-1dB bandwidth	Z <sub>L</sub> = 16 Ω		35		kHz
P <sub>OUT_OD</sub>	Output power	Z <sub>L</sub> = 16Ω V <sub>OD_IN</sub> = 70mV <sub>RMS</sub>	15	20		mW
THD <sub>OD</sub>	Distortion in Line Driver mode	V <sub>out</sub> = 0.5 V <sub>RMS</sub> , Z <sub>L</sub> = 10kΩ		0.2	0.3	%
THD <sub>OD</sub>	Distortion in Power Amplifier mode	with decoupling capacitor CDEC = 1μF/ceramic on pin 28. P <sub>out</sub> = 20 mW, Z <sub>L</sub> = 16Ω		0.35	0.8	%
V <sub>ISOL</sub>	Crosstalk: isolation between the two Audio Buffers	P <sub>out</sub> = 20 mW, Z <sub>L</sub> = 16Ω		51		dB
<b>Standby</b>						
V <sub>SBY_L</sub>	Low level input voltage of Standby inputs (Pins 31 & 32)				0.1xV <sub>CC</sub>	V
V <sub>SBY_H</sub>	High level input voltage of Standby inputs (Pins 31 & 32)		0.9xV <sub>CC</sub>			V
T <sub>ON</sub>	Turn-on time from Standby mode to Active mode			0.5		μs
T <sub>OFF</sub>	Turn-off time from Active mode to Standby mode			0.5		μs

OVERALL CIRCUIT

Supply current vs. Supply voltage

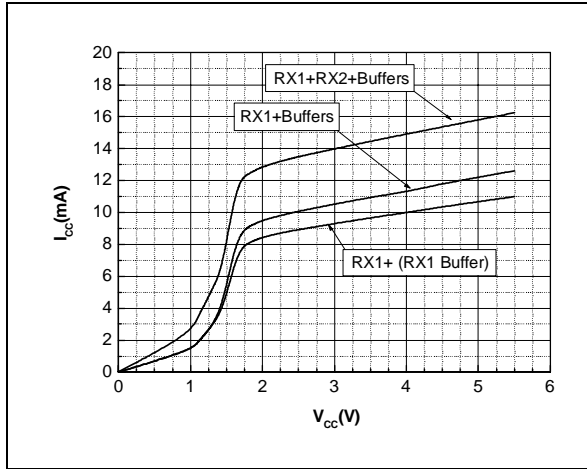

Squelch Threshold vs.  $R_{MUTE}$  Input Resistor

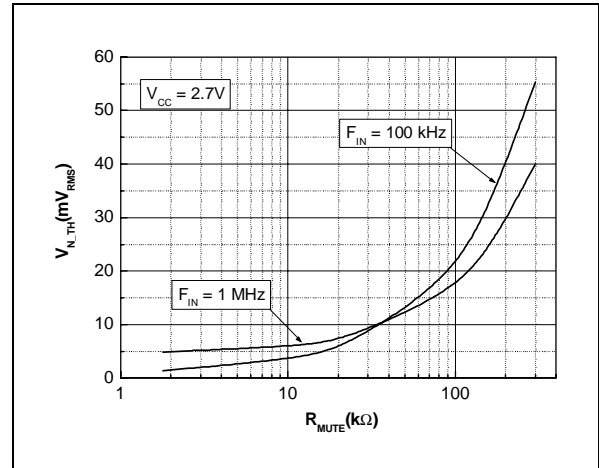

S/N vs. 2.8 MHz Input Level

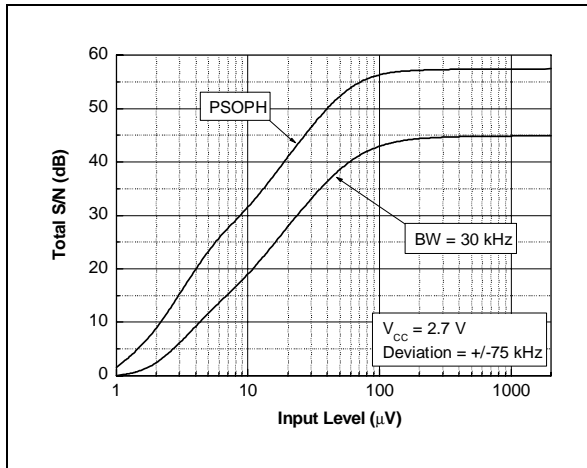

Supply current vs. Temperature

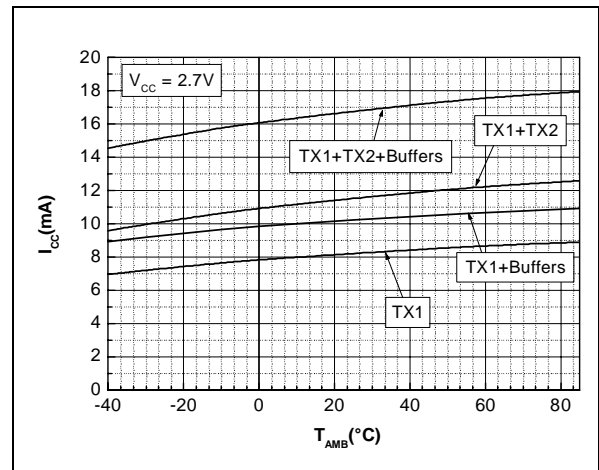

PSOPH: Signal on Noise Ratio curve measured with a CCITT standard psophometric bandpass characteristic. It approximates the response of human hearing.

Sensitivity vs. Supply Voltage

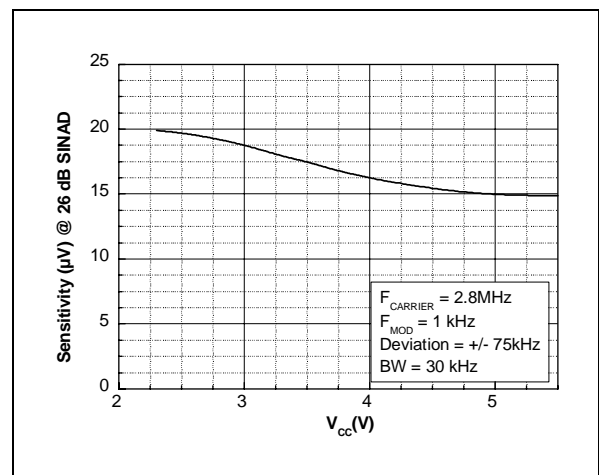

**AUDIO BUFFERS**

**Output THD+N vs. Output Power ( $R_L = 16 \Omega$ )**

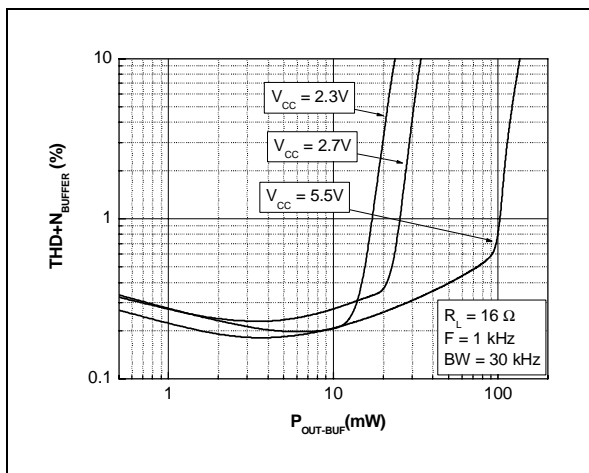

**Output THD+N vs. Output Power ( $R_L = 16 \Omega$ )**

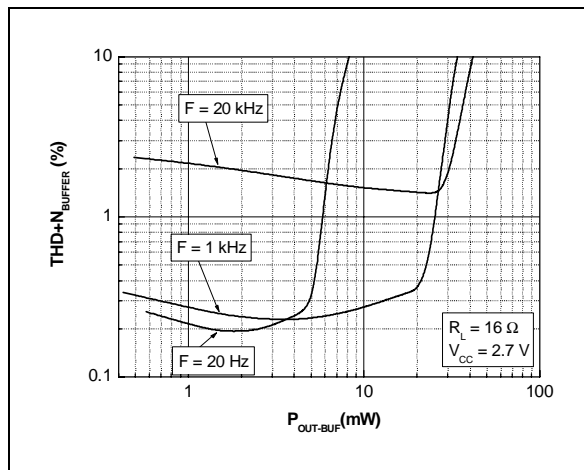

**Output THD+N vs. Output Power ( $R_L = 32 \Omega$ )**

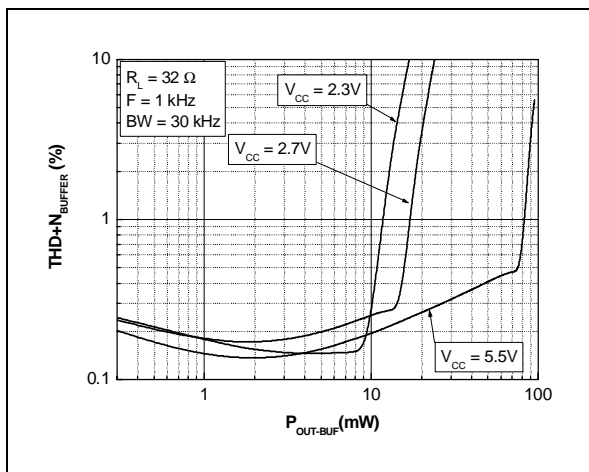

**Output THD+N vs. Output Power ( $R_L = 32 \Omega$ )**

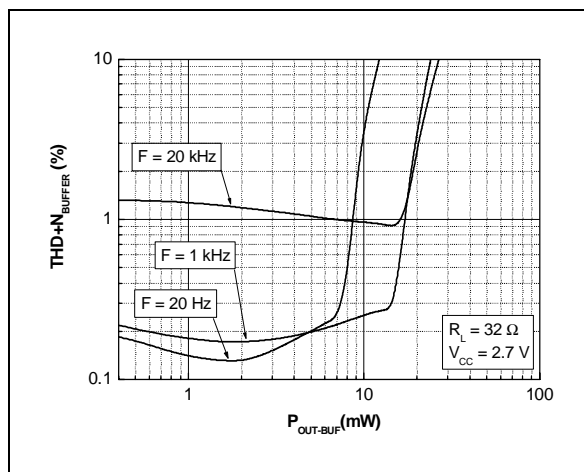

**Output THD+N vs. Output Power ( $R_L = 600 \Omega$ )**

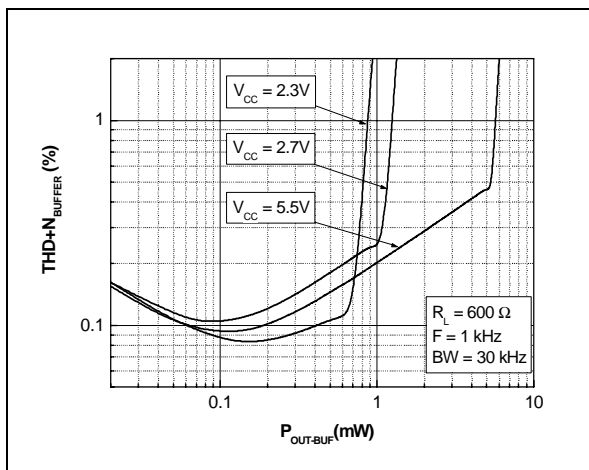

**Output THD+N vs. Output Power ( $R_L = 600 \Omega$ )**

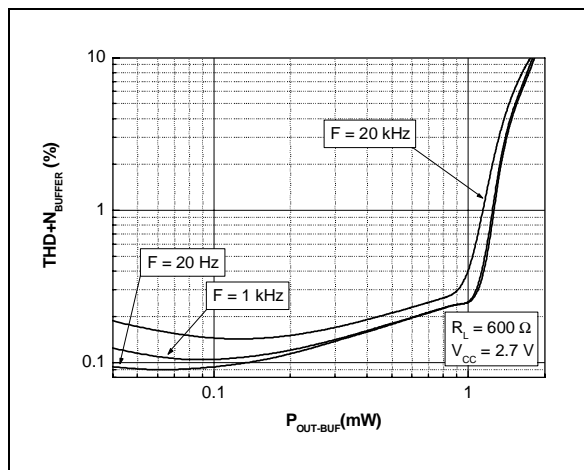

Output THD+N vs. Output Voltage (RL = 10kΩ)

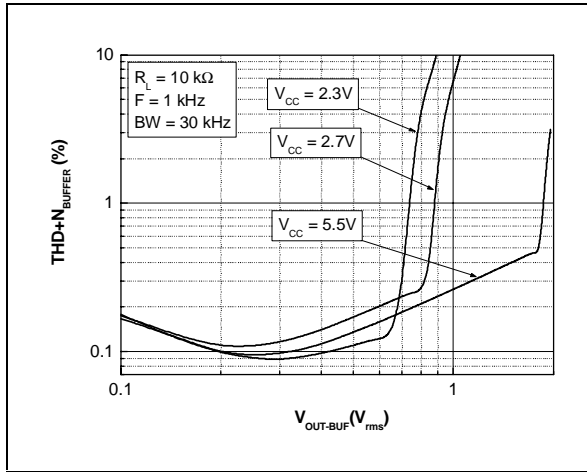

Output THD+N vs. Output Voltage (RL = 10kΩ)

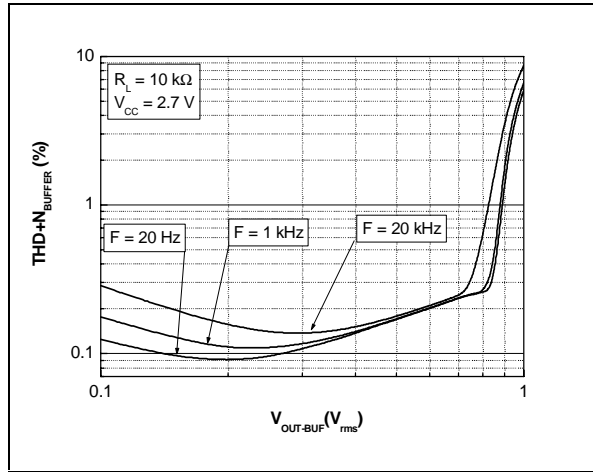

Output THD+N vs. Frequency (RL = 16 Ω)

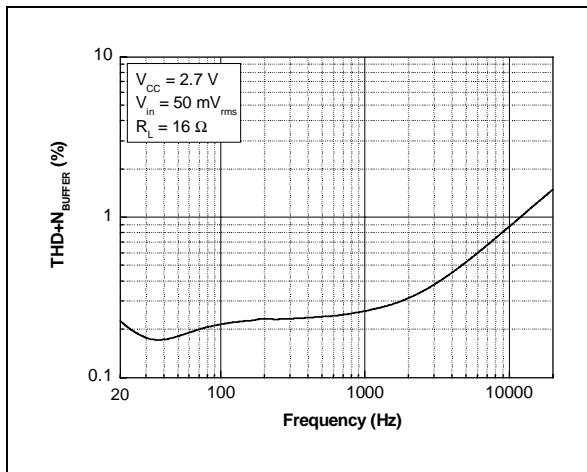

Output THD+N vs. Frequency (RL = 32 Ω)

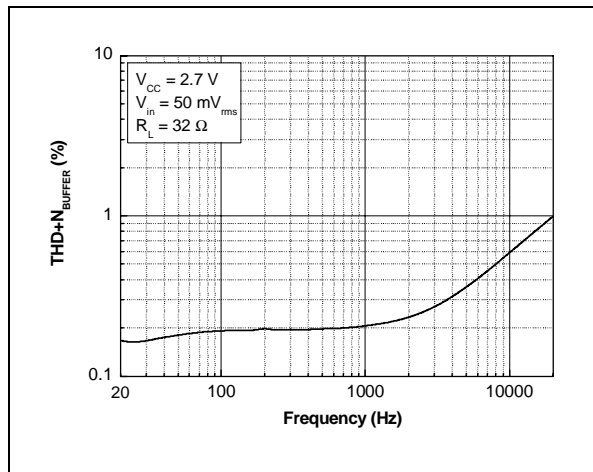

Output THD+N vs. Frequency (RL = 600 Ω)

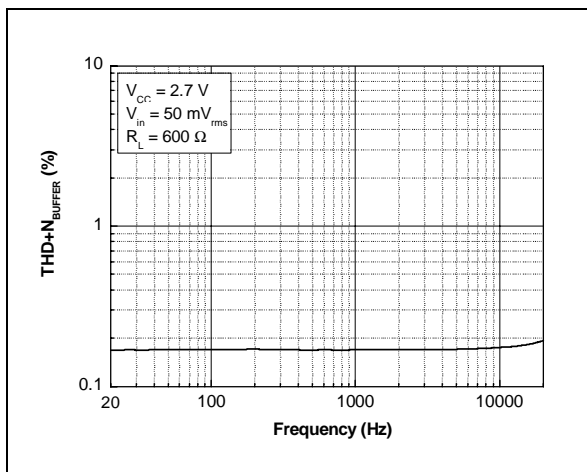

Output THD+N vs. Frequency (RL = 10 kΩ)

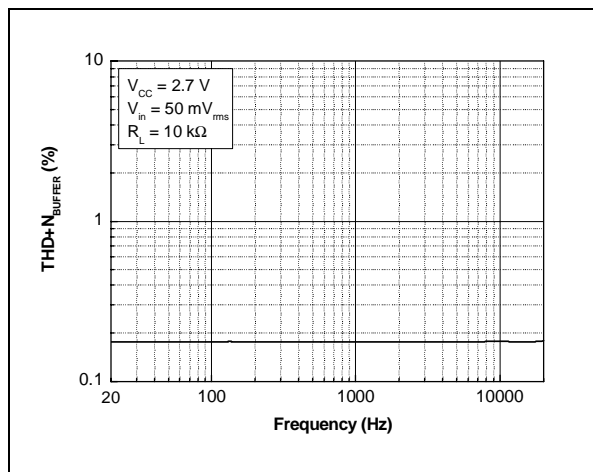

## Output Power vs. Temperature

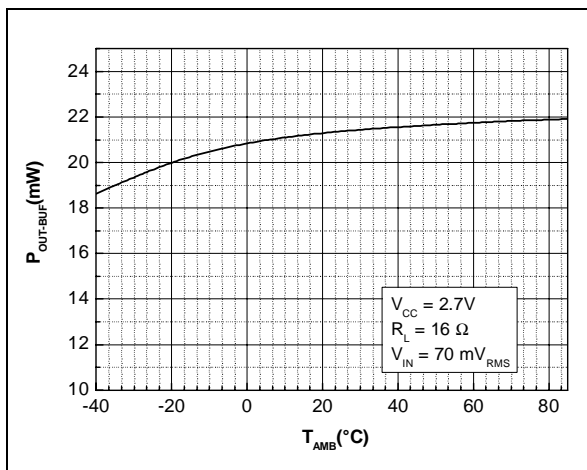

**GENERAL DESCRIPTION**

The TSH511 is a 0.4 to 11 MHz dual FM analogue receiver. The incoming signal is amplified with a 22 dB Low Noise Amplifier (LNA section). The good noise performance of the LNA allows the photodiode for infrared applications to be connected directly to the TSH511 without any external preamplifier. The access pins for each section and the two standby configurations allow a high versatility for many applications: HiFi stereo infrared receiver, mono/stereo subcarrier receiver, power line carrier audio.

**Figure 1 : TSH511 block diagram**

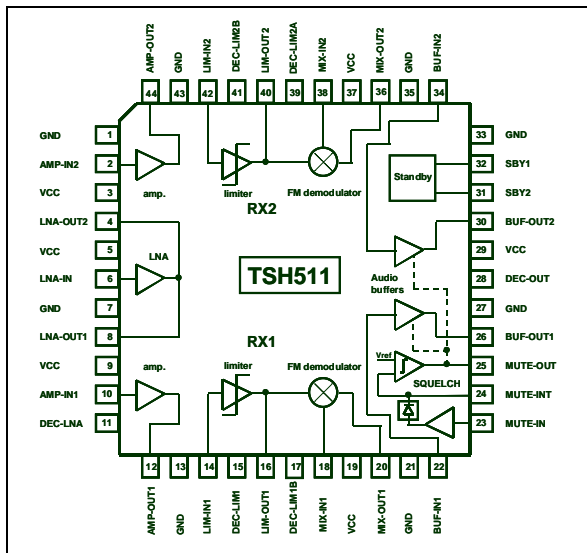

The LNA is common to both receivers but the output is split in two: one for each receiver. Each LNA output can be connected to a first optional filter for bandpass or reject filtering.

The filtered signal is amplified with an intermediate Amplifier (AMP section) followed by a second filter. The AMP sections have 20 dB typical gain.

Finally, the signal is amplified and limited in the Limiter (LIM section). The 60 dB amplifier-limiter LIM provides a constant amplitude signal to the demodulator. It reduces AM parasitics demodulation in the FM demodulator.

The FM demodulator is a classical quadrature detector using an external tank.

The demodulated signal can be amplified by the Audio Buffer section after de-emphasis. Each Audio Buffer can drive a 16 ohms headphone with 20 mW power.

The two standby pins SBY1 & SBY2 allow the second receiver RX2 to be put into standby for mono operation. In mono, it is possible to use both Audio

Buffers or only one depending on the combination on SBY1 & SBY2.

To avoid noise at the audio output, a Squelch section mutes the Audio Buffers when no carrier is received. The Squelch Section uses the demodulated signal of the first receiver (RX1). This signal is highpass filtered, rectified and compared to a threshold to produce the Mute signal (pin 25). When no carrier is received on RX1, the wideband 'FM noise' on the demodulator increases and the Mute signal mutes the both Audio Buffers. When the carrier is present, the wideband noise on the demodulator output decreases, enabling the Audio Buffers.

**Figure 2 : Infrared audio frequencies**

IR frequency	applications
1.6 MHz	AM mono
1.7 MHz	FM mono
2.3 MHz	FM right channel
2.8 MHz	FM left channel or mono

**LNA section: Low Noise Amplifier**

The Low Noise Amplifier (LNA) has a typical gain of 22 dB to amplify the incoming RF signal from the photodiode. The LNA is common to both receivers sections RX1 and RX2.

**Figure 3 : LNA schematic**

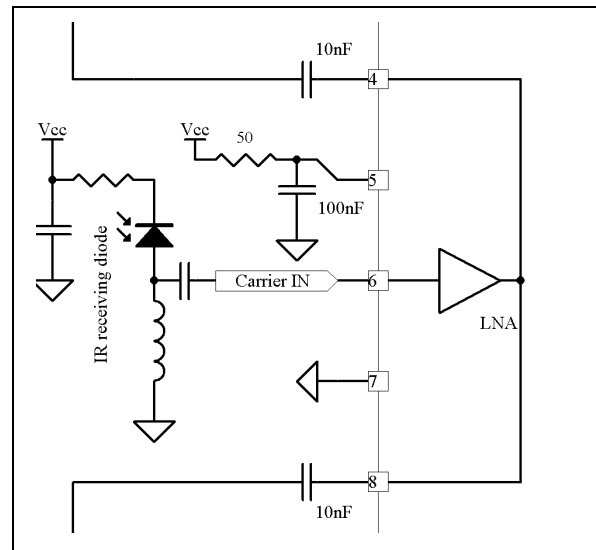

The LNA output is directly connected to LNA-OUT1 and LNA-OUT2 pins in parallel (pin 8 and 4 respectively). As the LNA minimum impedance load is  $1\text{ k}\Omega$ , the load impedance on each pin LNA-OUT1 or LNA-OUT2 must be  $2\text{ k}\Omega$  minimum. The series  $50\ \Omega$  resistor and the  $100\text{ nF}$  capacitor decouple the LNA supply voltage (pin 5), improving noise performance.

#### AMP and LIM sections: Amplifier and Limiter

The first filter output is connected to the intermediate amplifier AMP. The gain of AMP is typically  $20\text{ dB}$ . The second filter is connected between the output of AMP and the input of the limiter LIM. The  $60\text{ dB}$  limiter LIM provides a constant amplitude signal to the FM demodulator. It reduces the AM parasitic effects into the FM demodulator.

Figure 4 : AMP and LIM schematic

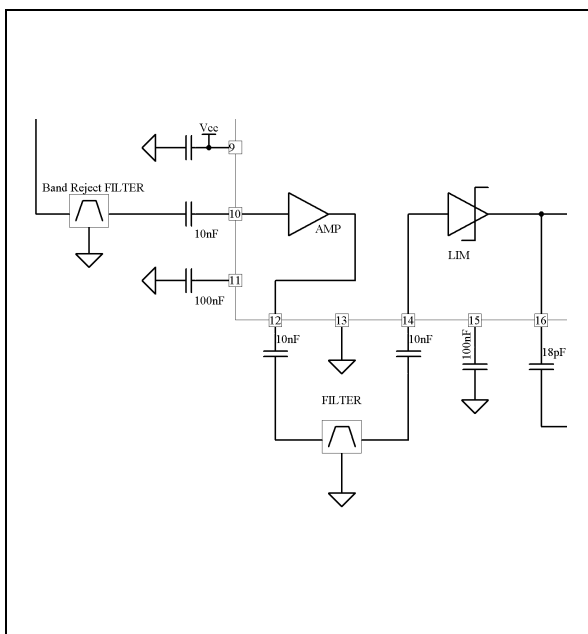

#### FM demodulator section

The FM demodulator is a classical quadrature demodulator based on a multiplier. The quadrature is performed with the tank circuit  $L_{lo}$  inductor and  $C_{lo}$  capacitor. The tank circuit is tuned on the receiving frequency.

The  $R_{lo}$  resistor is connected in parallel with  $L_{lo}$  and  $C_{lo}$  to reduce the Q factor of the tank circuit. It

allows to adjustment of the demodulation characteristic. For a given transmitting deviation, a lower value of  $R_{lo}$  gives a lower demodulated amplitude and reduces the distortion.

The AC amplitude on pin 18 must not exceed  $300\text{ mV}_{\text{RMS}}$  to prevent clipping by the internal ESD diodes of the circuit.

The low output impedance of the demodulator (MIX-OUT pins) drives the external volume control and the de-emphasis filter.

Figure 5 : FM demodulator schematic

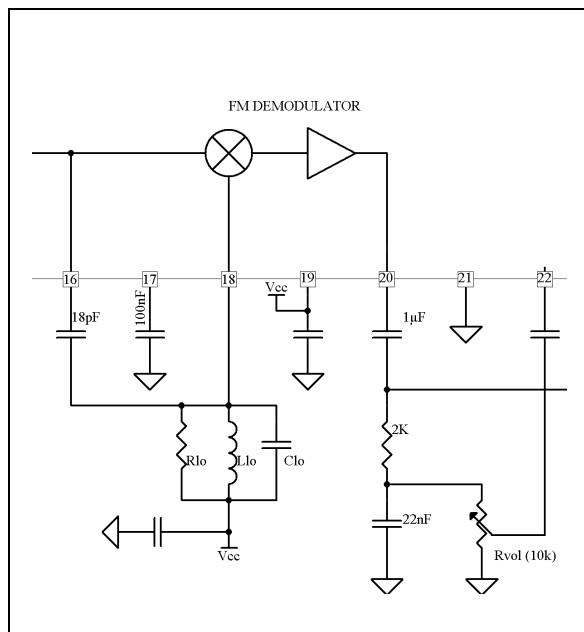

#### SQUELCH section

To avoid audio 'FM noise' at the speakers when no carrier is received, the TSH511 has a built-in Squelch circuit. The Squelch detects the wide-band 'FM noise' on the demodulated output and fades-out the audio of both audio buffers.

The audio is filtered from the 'FM noise' using the high-pass RC filter. The cut-off frequency is typically  $100\text{ kHz}$ . The squelch level depends on the value of the  $R_{\text{MUTE}}$  resistor in serie with the input pin of the noise amplifier MUTE-IN (pin 23). The detected noise is integrated with the  $C_{\text{peak}}$  capacitor connected to MUTE-INT pin. The DC voltage on this pin follows the amplitude of the noise.

The comparator and the C<sub>MUTE</sub> capacitor generate the fade-in and fade-out control ramps for the audio buffers. The Squelch has been designed with particular attention to avoid audio pop-noise.

Figure 6 : Squelch schematic

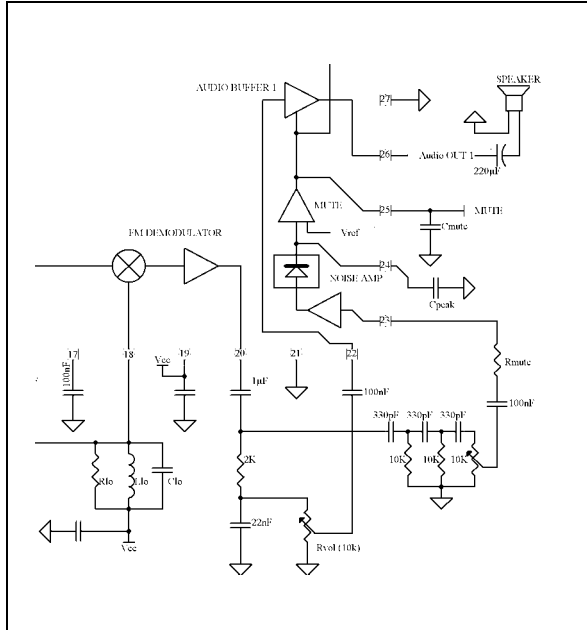

The squelch section is driven by the receiver RX1 but controls both audio buffers.

**Audio Buffer sections**

The audio signal from a FM demodulator enters into the 6dB/octave low-pass filter for de-emphasis. 50µs and 75µs are standard de-emphasis values.

After the de-emphasis network, the potentiometer controls the volume.

The Rail-to-Rail output stage of each Audio Buffer is able to drive 20 mW into 16Ω at 2.3V supply voltage. In this condition, the distortion is typically 0.3% before saturation.

The Audio Buffers can also drive the other usual impedances used in audio: 32Ω, 600Ω and 10kΩ (see the corresponding distortion curves).

The high input impedances of the Audio Buffers reduce the coupling capacitors to less than 0.1 µF allowing space and cost saving.

**Standby section**

Depending on the states of the logic inputs SBY1 and SBY2, RX2 and the Audio Buffer2 can be disabled separately. The TSH511 receiver can adapt to different applications by using SBY1 & SBY2 standby pins:

SBY1 pin 32	SBY2 pin 31	RX1 & audio buffer1	RX2	audio buffer 2	typical use
Low	Low	ON	ON	ON	stereo
Low	High	ON	OFF	ON	mono on the two outputs
High	Low	ON	OFF	ON	mono on one output
High	High	ON	OFF	OFF	mono on one output

In the standard stereo mode, the configuration is: SBY1 = SBY2 = 'Low'

In mono mode with one load (example: a single loadspeaker), RX2 and Audio Buffer 2 are disabled, the configuration is SBY1 = SBY2 = 'High'.

In mono mode with a stereo load (example: a stereo headphone), the configuration is SBY1 = 'high', SBY2 = 'Low'.

A pin connected to Vcc is at 'High' state, and if connected to GND is at 'Low' state.



**APPLICATION SCHEMATIC**

The infrared carriers are detected by the photodiode and the signal is directly amplified by the TSH511. Optional reject filters can be added in each channel to improve crosstalk performances. Each receiver has a standard bandpass filter (filters F1 & F3) to select the 2.3 and 2.8 MHz carriers. After the FM demodulators, the potentiometers P1 and P2 control the volume levels. The stereo headphones are directly connected to the integrated audio buffers. The potentiometer P3 allows adjustment of the sensitivity of the Squelch. The Squelch function fade-in and fade-out the audio signal depending on the level of the 2.8 MHz carrier.

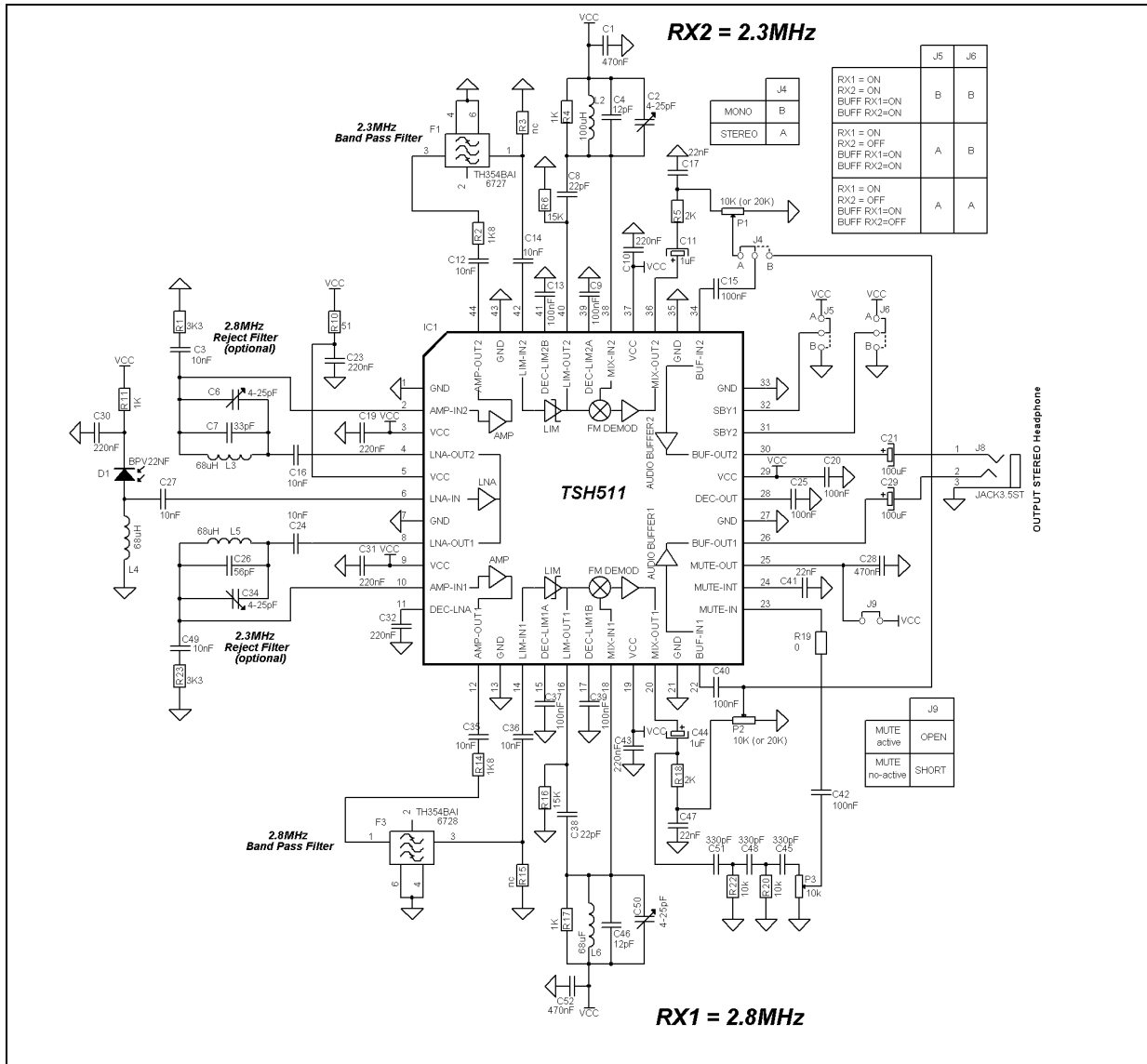

**PACKAGE MECHANICAL DATA**  
44 PINS - PLASTIC PACKAGE

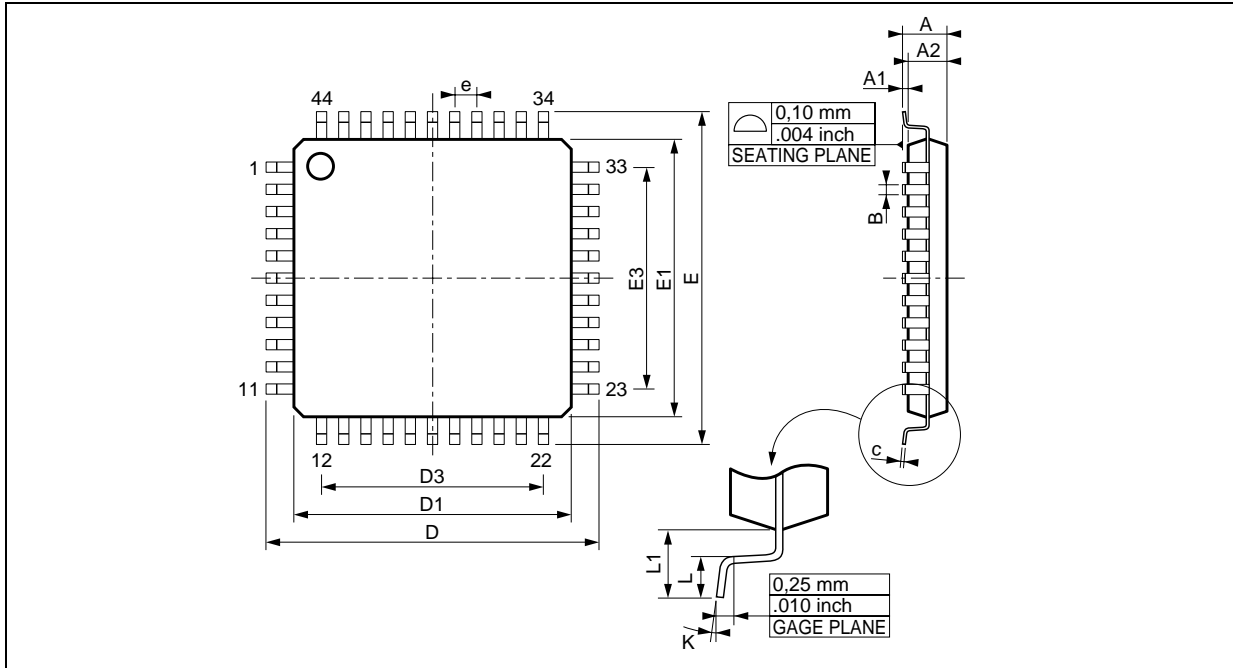

Dimensions	Millimeters			Inches		
	Min.	Typ.	Max.	Min.	Typ.	Max.
A			1.60			0.063
A1	0.05		0.15	0.002		0.006
A2	1.35	1.40	1.45	0.053	0.055	0.057
B	0.30	0.37	0.40	0.012	0.015	0.016
C	0.09		0.20	0.004		0.008
D		12.00			0.472	
D1		10.00			0.394	
D3		8.00			0.315	
e		0.80			0.031	
E		12.00			0.472	
E1		10.00			0.394	
E3		8.00			0.315	
L	0.45	0.60	0.75	0.018	0.024	0.030
L1		1.00			0.039	
K	0° (min.), 7° (max.)					

Information furnished is believed to be accurate and reliable. However, STMicroelectronics assumes no responsibility for the consequences of use of such information nor for any infringement of patents or other rights of third parties which may result from its use. No license is granted by implication or otherwise under any patent or patent rights of STMicroelectronics. Specifications mentioned in this publication are subject to change without notice. This publication supersedes and replaces all information previously supplied. STMicroelectronics products are not authorized for use as critical components in life support devices or systems without express written approval of STMicroelectronics.

The ST logo is a registered trademark of STMicroelectronics

© 2002 STMicroelectronics - All Rights Reserved  
STMicroelectronics GROUP OF COMPANIES

Australia - Brazil - China - Finland - France - Germany - Hong Kong - India - Italy - Japan - Malaysia - Malta - Morocco  
Singapore - Spain - Sweden - Switzerland - United Kingdom

<http://www.st.com>