



# TSH95

## HIGH SPEED LOW POWER QUAD OPERATIONAL AMPLIFIER WITH DUAL **STANDBY** POSITION

- **2 SEPARATE STANDBY : REDUCED CONSUMPTION AND HIGH IMPEDANCE OUTPUTS**
- LOW SUPPLY CURRENT : 4.5mA
- HIGH SPEED : 150MHz - 110V/μs
- UNITY GAIN STABILITY
- LOW OFFSET VOLTAGE : 4mV
- LOW NOISE 4.2 nV/√Hz
- LOW COST
- SPECIFIED FOR **600Ω** AND **150Ω** LOADS
- HIGH VIDEO PERFORMANCES :
  - Differential Gain : 0.03%
  - Differential Phase : 0.07°
  - Gain Flatness : 6MHz, 0.1dB max. @ 10dB gain
- HIGH AUDIO PERFORMANCES
- ESD TOLERANCE : 2kV

### DESCRIPTION

The TSH95 is a quad low power high frequency op-amp, designated for high quality video processing. The device offers an excellent speed consumption ratio with 4.5mA per amplifier for 150MHz bandwidth.

High slew rate and low noise make it also suitable for high quality audio applications.

The TSH95 offers 2 separate complementary **STANDBY pins** :

- STANDBY 1 acting on both n° 1 & 2 operators
- STANDBY 2 acting on both n° 3 & 4 operators

They reduce the consumption of the corresponding operators and put the output in a high impedance state.

### ORDER CODE

Part Number	Temperature Range	Package
		D
TSH95I	-40°C, +125°C	•

D = Small Outline Package (SO) - also available in Tape & Reel (DT)

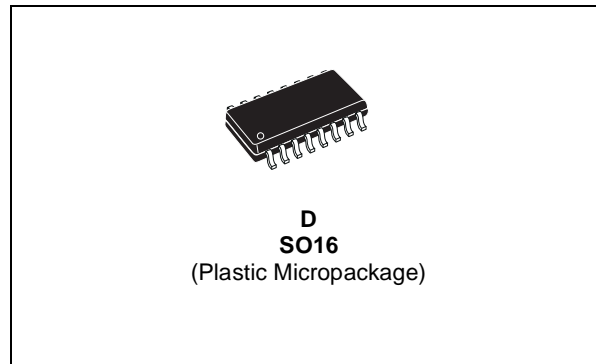

### PIN CONNECTIONS (top view)

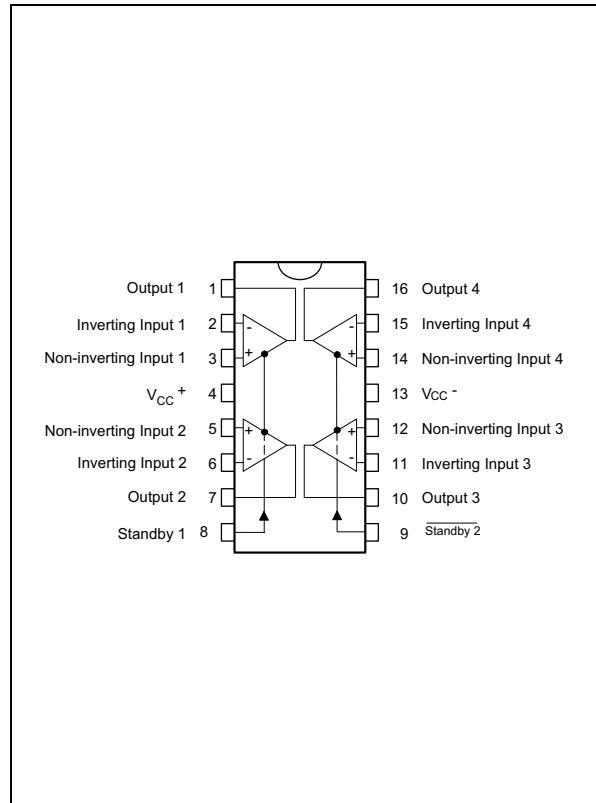

SCHEMATIC DIAGRAM

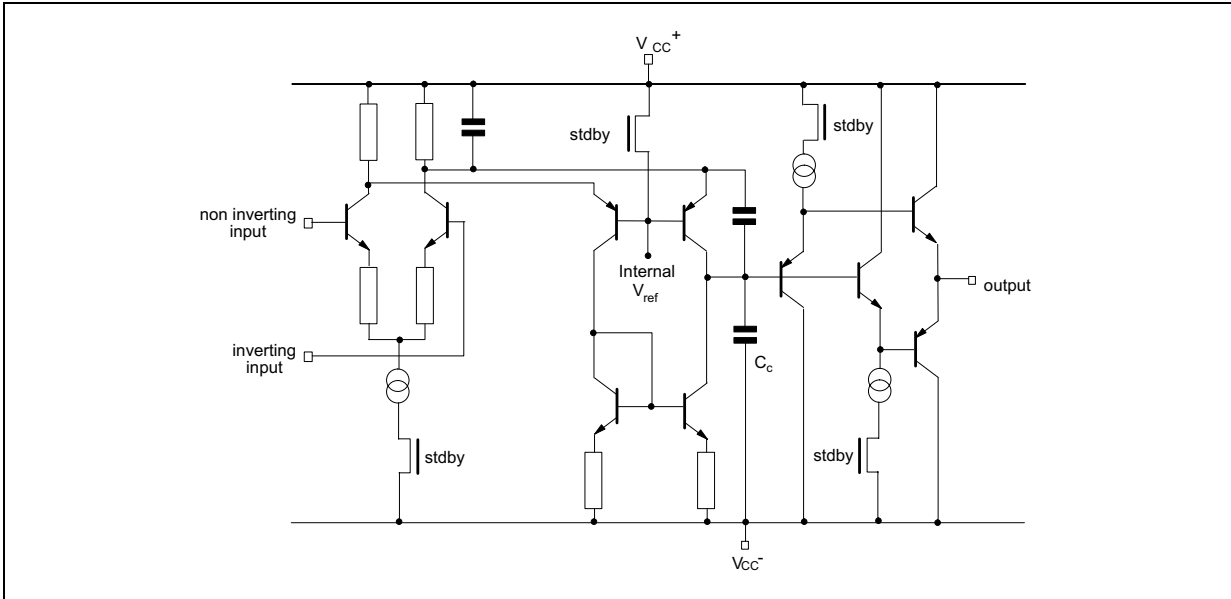

MAXIMUM RATINGS

Symbol	Parameter	Value	Unit
$V_{CC}$	Supply Voltage <sup>1)</sup>	14	V
$V_{id}$	Differential Input Voltage <sup>2)</sup>	$\pm 5$	V
$V_i$	Input Voltage <sup>3)</sup>	-0.3 to 12	V
$T_{oper}$	Operating Free-Air Temperature range	-40 to +125	°C
$T_{stg}$	Storage Temperature Range	-65 to +150	°C

1. All voltages values, except differential voltage are with respect to network ground terminal
2. Differential voltages are the non-inverting input terminal with respect to the inverting input terminal
3. The magnitude of input and output voltages must never exceed  $V_{CC}^+ + 0.3V$

OPERATING CONDITIONS

Symbol	Parameter	Value	Unit
$V_{CC}$	Supply Voltage	7 to 12	V
$V_{ic}$	Common Mode Input Voltage Range	$V_{CC}^- + 2$ to $V_{CC}^+ - 1$	V

**ELECTRICAL CHARACTERISTICS**

$V_{CC}^+ = 5V$ ,  $V_{CC}^- = -5V$ , pin 8 connected to 0V, pin 9 connected to  $V_{CC}^+$ ,  $T_{amb} = 25^\circ C$   
(unless otherwise specified)

Symbol	Parameter	Min.	Typ.	Max.	Unit
$V_{io}$	Input Offset Voltage $V_{ic} = V_o = 0V$ $T_{min.} \leq T_{amb} \leq T_{max.}$			4 6	mV
$I_{io}$	Input Offset Current $T_{min.} \leq T_{amb} \leq T_{max.}$		1	2 5	$\mu A$
$I_{ib}$	Input Bias Current $T_{min.} \leq T_{amb} \leq T_{max.}$		5	15 20	$\mu A$
$I_{CC}$	Supply Current (per amplifier, no load) $T_{min.} \leq T_{amb} \leq T_{max.}$		4.5	6 8	mA
CMR	Common-mode Rejection Ratio $V_{ic} = -3V$ to $+4V$ , $V_o = 0V$ $T_{min.} \leq T_{amb} \leq T_{max.}$	80 70	100		dB
SVR	Supply Voltage Rejection Ratio $V_{CC} = \pm 5V$ to $\pm 3V$ $T_{min.} \leq T_{amb} \leq T_{max.}$	60 50	75		dB
$A_{vd}$	Large Signal Voltage Gain $R_L = 10k\Omega$ , $V_o = \pm 2.5V$ $T_{min.} \leq T_{amb} \leq T_{max.}$	57 54	70		dB
$V_{OH}$	High Level Output Voltage $V_{id} = 1V$ $T_{min.} \leq T_{amb} \leq T_{max.}$ $R_L = 600\Omega$ $R_L = 150\Omega$ $R_L = 150\Omega$	3 2.5 2.4	3.5 3		V
$V_{OL}$	Low Level Output Voltage $V_{id} = 11V$ $T_{min.} \leq T_{amb} \leq T_{max.}$ $R_L = 600\Omega$ $R_L = 150\Omega$ $R_L = 150\Omega$		-3.5 -2.8	-3 -2.5 -2.4	V
$I_o$	Output Short Circuit Current $V_{id} = \pm 1V$ $T_{min.} \leq T_{amb} \leq T_{max.}$ Source Sink Source Sink	20 20 15 15	36 40		mA
GBP	Gain Bandwidth Product $A_{VCL} = 100$ , $R_L = 600\Omega$ , $C_L = 15pF$ , $f = 7.5MHz$	90	150		MHz
$f_T$	Transition Frequency		90		MHz
SR	Slew Rate $V_{in} = -2$ to $+2V$ , $A_{VCL} = +1$ , $R_L = 600\Omega$ , $C_L = 15pF$	62	110		V/ $\mu s$
$e_n$	Equivalent Input Voltage Noise $R_s = 50\Omega$ , $f = 1kHz$		4.2		nV/ $\sqrt{Hz}$
$\phi_m$	Phase Margin $A_{VM} = +1$		35		Degrees
$V_{O1}/V_{O2}$	Channel Separation $f = 1MHz$ to $10MHz$		65		dB
Gf	Gain Flatness $f = DC$ to $6MHz$ , $A_{VCL} = 10dB$			0.1	dB
THD	Total Harmonic Distortion $f = 1kHz$ , $V_o = \pm 2.5V$ , $R_L = 600\Omega$		0.01		%
$\Delta G$	Differential Gain $f = 3.58MHz$ , $A_{VCL} = +2$ , $R_L = 150\Omega$		0.03		%
$\Delta \phi$	Differential Phase $f = 3.58MHz$ , $A_{VCL} = +2$ , $R_L = 150\Omega$		0.07		Degree

**STANDBY MODE**  $V_{CC}^+ = 5V$ ,  $V_{CC}^- = -5V$ ,  $T_{amb} = 25^\circ C$  (unless otherwise specified)

Symbol	Parameter	Min.	Typ.	Max.	Unit
$V_{SBY}$	Pin 8/9 Threshold Voltage for STANDBY Mode	$V_{CC}^+ - 2.2$	$V_{CC}^+ - 1.6$	$V_{CC}^+ - 1.0$	V
$I_{CC\ SBY}$	Total Consumption				mA
	Pin 8 (Standby 1) = 0, Pin 9 (Standby 2) = 0		9.4		
	Pin 8 (Standby 1) = 0, Pin 9 (Standby 2) = 1		9.4		
	Pin 8 (Standby 1) = 1, Pin 9 (Standby 2) = 0		0.8		
$I_{sol}$	Input/Output Isolation (f = 1MHz to 10MHz)		70		dB
$t_{ON}$	Time from Standby Mode to Active Mode		200		ns
$t_{OFF}$	Time from Active Mode to Standby Mode		200		ns
$I_D$	Standby Driving Current		2		pA
$I_{OL}$	Output Leakage Current		20		pA
$I_{IL}$	Input Leakage Current		20		pA

LOGIC INPUT		STATUS	
Standby 1	Standby 2	Op-Omp 1 & 2	Op-Amp 2 & 3
0	0	Enable	Standby
0	1	Enable	Enable
1	0	Standby	Standby
1	1	Standby	Enable

**STANDBY POSITION**

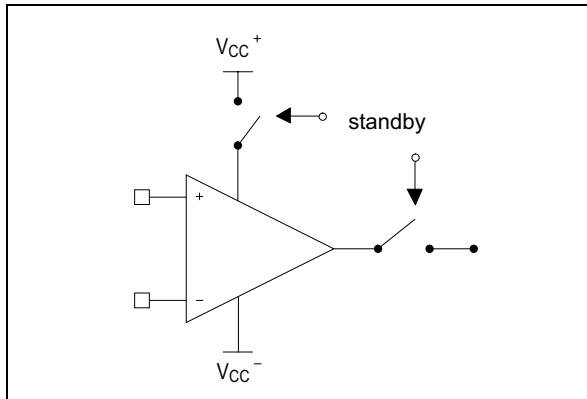

**STANDBY MODE**

To put the device in standby, just apply a logic level on the standby MOS input. As ground is a virtual level for the device, threshold voltage has been referred to  $V_{CC}^+$  at  $V_{CC}^+ - 1.6V$  typ.

In standby mode, the output goes in high impedance in 200ns. Be aware that all maximum rating must still be followed in this mode. It leads to swing limitation while using the device in signal multiplexing configuration with followers, differential input voltage must not exceed  $\pm 5V$  limiting input swing to 2.5Vpp.

**APPLICATIONS**

**SIGNAL MULTIPLEXING**

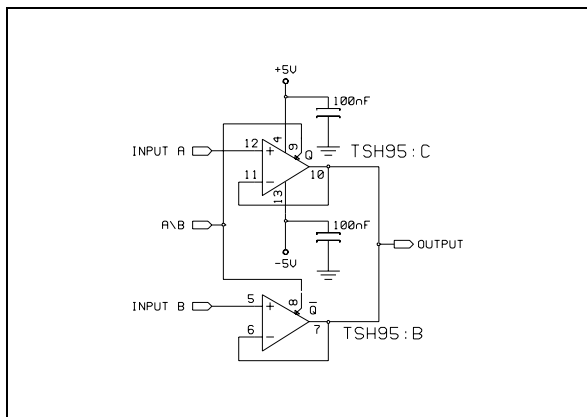

**SAMPLE AND HOLD**

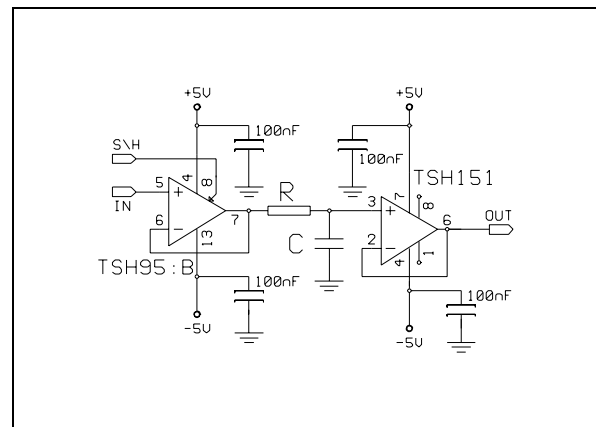

## PRINTED CIRCUIT LAYOUT

As for any high frequency device, a few rules must be observed when designing the PCB to get the best performances from this high speed op amp.

From the most to the least important points :

- ❑ Each power supply lead has to be by-passed to ground with a 10nF ceramic capacitor very close to the device and 10 $\mu$ F capacitor.
- ❑ To provide low inductance and low resistance common return, use a ground plane or common point return for power and signal.
- ❑ All leads must be wide and as short as possible especially for op amp inputs. This is in order to decrease parasitic capacitance and inductance.
- ❑ Use small resistor values to decrease time constant with parasitic capacitance.
- ❑ Choose component sizes as small as possible (SMD).
- ❑ On output, decrease capacitor load so as to avoid circuit stability being degraded which may cause oscillation. You can also add a serial resistor in order to minimise its influence.

## INPUT OFFSET VOLTAGE DRIFT VERSUS TEMPERATURE

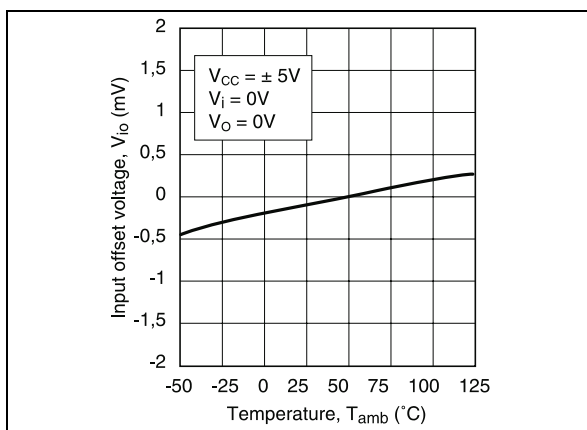

## LARGE SIGNAL FOLLOWER RESPONSE

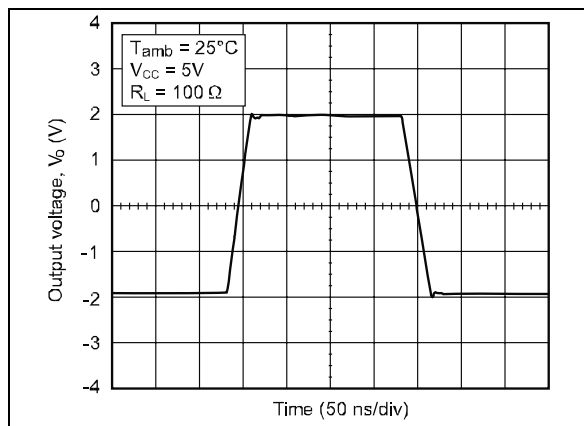

## STATIC OPEN LOOP VOLTAGE GAIN

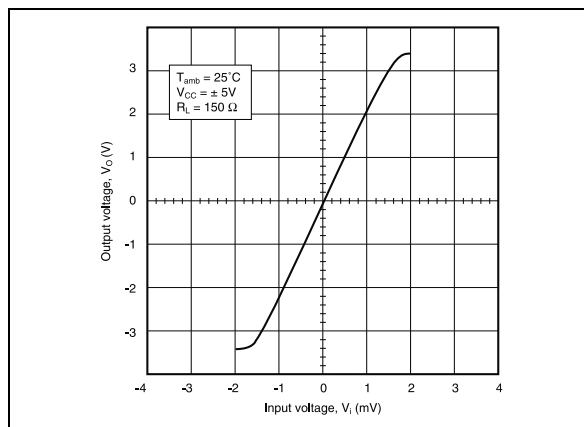

## SMALL SIGNAL FOLLOWER RESPONSE

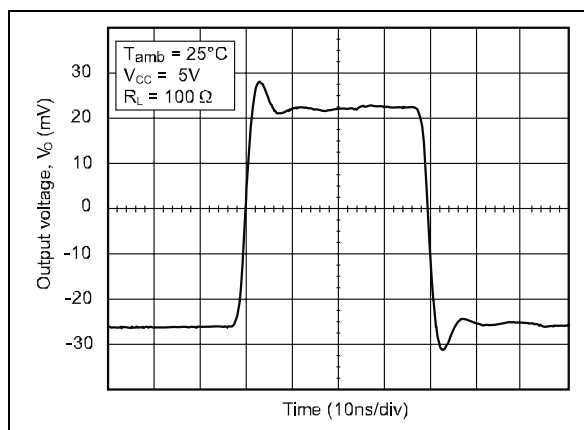

**CLOSE LOOP FREQUENCY RESPONSE AND PHASE SHIFT**

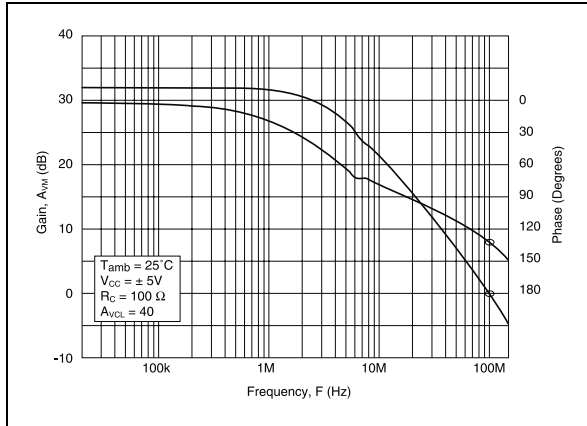

**CLOSE LOOP FREQUENCY RESPONSE**

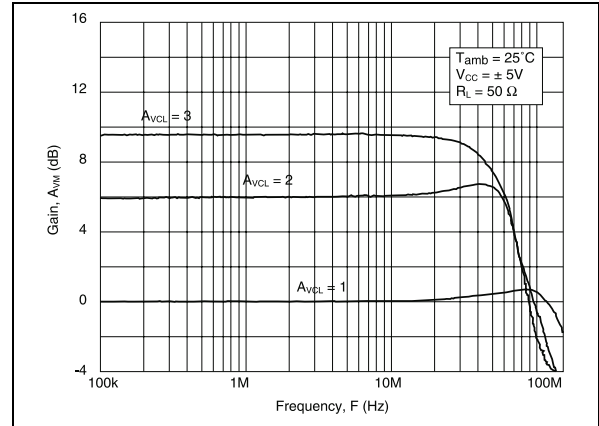

**AUDIO BANDWIDTH FREQUENCY RESPONSE AND PHASE SHIFT (TSH94 vs Standard 15MHz Audio Op-Amp)**

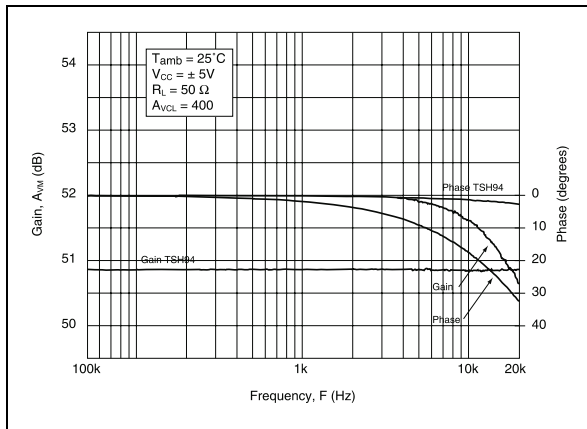

**GAIN FLATNESS AND PHASE SHIFT VERSUS FREQUENCY**

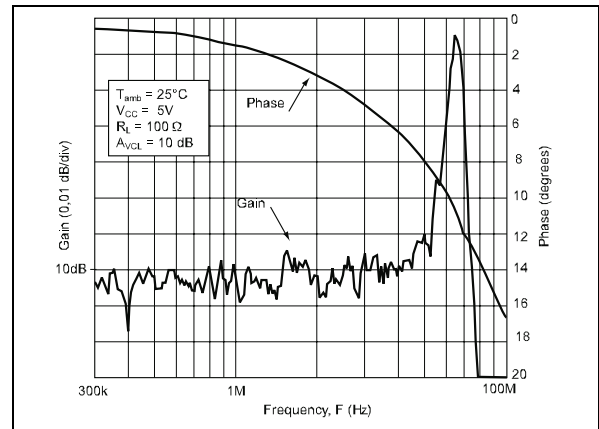

**CROSS TALK ISOLATION VERSUS FREQUENCY (SO16 PACKAGE)**

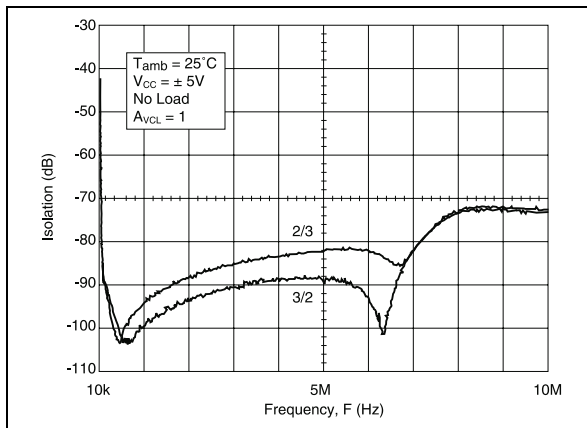

**CROSS TALK ISOLATION VERSUS FREQUENCY (SO16 PACKAGE)**

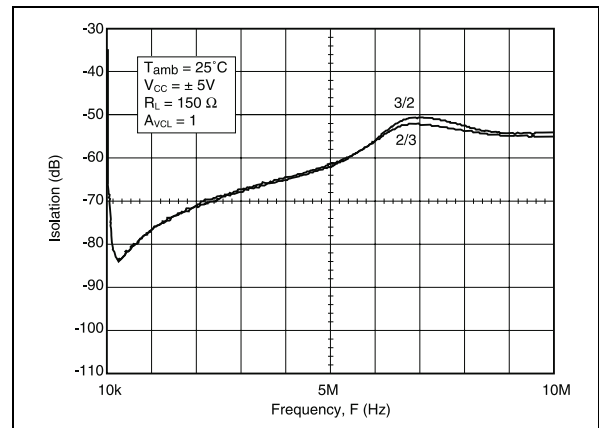

**INPUT/OUTPUT ISOLATION IN STANDBY MODE (SO16 PACKAGE)**

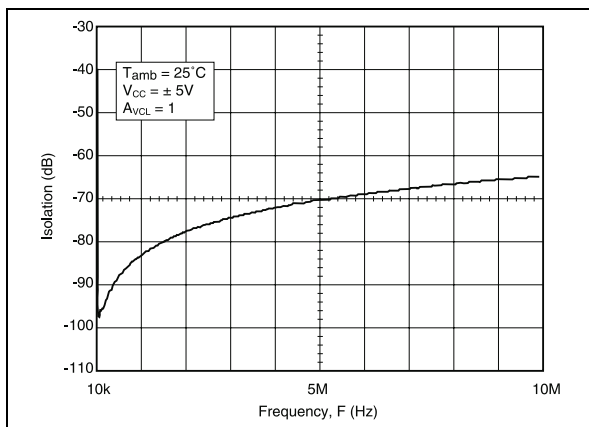

**STANDBY SWITCHING**

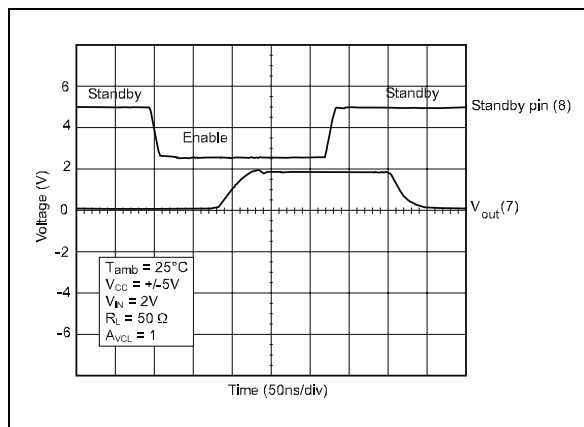

**SIGNAL MULTIPLEXING (cf p. 5/10)**

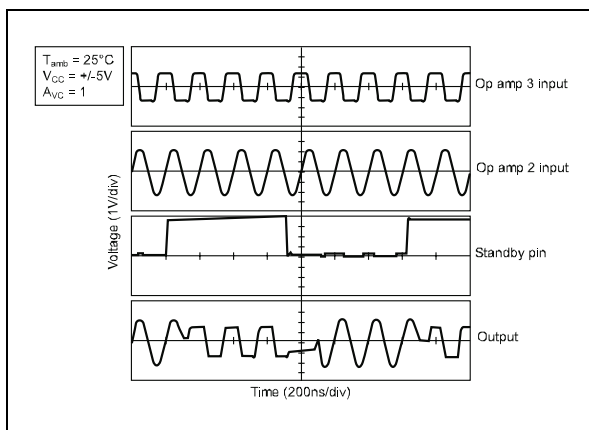

**DIFFERENTIAL INPUT IMPEDANCE VERSUS FREQUENCY**

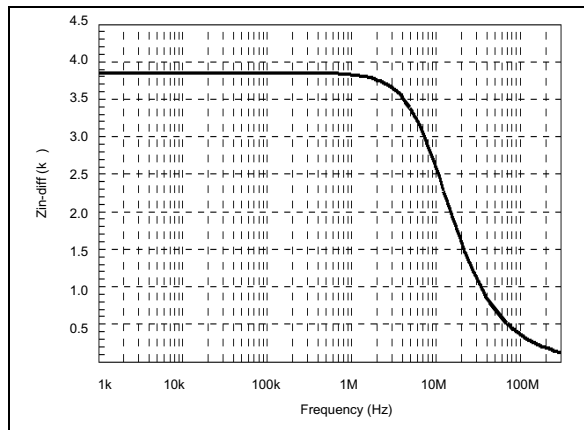

**COMMON INPUT IMPEDANCE VERSUS FREQUENCY**

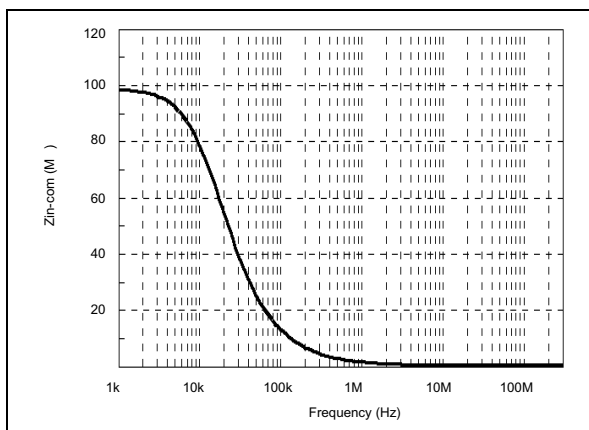

**MACROMODEL**

**Applies to: TSH95I**

\*\* Standard Linear Ics Macromodels, 1996.

\*\* CONNECTIONS :

- \* 1 INVERTING INPUT
- \* 2 NON-INVERTING INPUT
- \* 3 OUTPUT
- \* 4 POSITIVE POWER SUPPLY
- \* 5 NEGATIVE POWER SUPPLY
- \* 6 STANDBY

.SUBCKT TSH95 1 3 2 4 5 6 (analog)

\*\*\*\*\*

\*\*\*\*\* switch \*\*\*\*\*

.SUBCKT SWITCH 20 10 IN OUT COM

.MODEL DIDEAL D N=0.1 IS=1E-08

DP IN 1 DIDEAL 400E-12

DN OUT 2 DIDEAL 400E-12

EP 1 OUT COM 10 2

EN 2 IN COM 10 2

RFUIT1 IN 1 1E+09

RFUIT2 OUT 2 1E+09

RCOM COM 0 1E+12

.ENDS SWITCH

\*\*\*\*\* inverter \*\*\*\*\*

.SUBCKT INV 20 10 IN OUT

.MODEL DIDEAL D N=0.1 IS=1E-08

RP1 20 15 1E+09

RN1 15 10 1E+09

RIN IN 10 1E+12

RIP IN 20 1E+12

DPINV OUT 20 DIDEAL 400E-12

DNINV 10 OUT DIDEAL 400E-12

GINV 0 OUT IN 15 -6.7E-7

CINV 0 OUT 210f

.ENDS INV

\*\*\*\*\* AOP \*\*\*\*\*

.MODEL MDTH D IS=1E-8 KF=1.809064E-15

CJO=10F

\* INPUT STAGE

CIP 2 5 1.000000E-12

CIN 1 5 1.000000E-12

EIP 10 5 2 5 1

EIN 16 5 1 5 1

RIP 10 11 2.600000E-01

RIN 15 16 2.600000E-01

RIS 11 15 3.645298E-01

DIP 11 12 MDTH 400E-12

DIN 15 14 MDTH 400E-12

VOFP 12 13 DC 0.000000E+00

VOFN 1314DC 0

FPOL 13 5 VSTB 1E+03

CPS 11 15 2.986990E-10

DINN 17 13 MDTH 400E-12

VIN 17 5 2.000000E+00

DINR 15 18 MDTH 400E-12

VIP 4 18 1.000000E+00

FCP 4 5 VOFP 3.500000E+00

FCN 5 4 VOFN 3.500000E+00

ISTB0 4 5 130UA

FIBP 2 5 VOFP 1.000000E-02

FIBN 5 1 VOFN 1.000000E-02

\* AMPLIFYING STAGE

FIP 5 19 VOFP 2.530000E+02

FIN 5 19 VOFN 2.530000E+02

RG1 19 120 3.160721E+03

XCOM1 4 0 120 5 COM SWITCH

RG2 19 121 3.160721E+03

XCOM2 4 0 4 121 COM SWITCH

CC 19 5 2.000000E-09

DOPM 19 22 MDTH 400E-12

DONM 21 19 MDTH 400E-12

HOPM 22 28 VOUT 1.504000E+03

VIPM 28 4 5.000000E+01

HONM 21 27 VOUT 1.400000E+03

VINM 5 27 5.000000E+01

\*\*\*\*\* ZP \*\*\*\*\*

RZP1 5 80 1E+06

RZP2 4 80 1E+06

GZP 5 82 19 80 2.5E-05

RZP2H 83 4 10000

RZP1H 83 82 80000

RZP2B 84 5 10000

RZP1B 82 84 80000

LZPH 4 83 3.535e-02

LZPB 84 5 3.535e-02

\*\*\*\*\*

EOUT26 2382 51

VOUT 23 5 0

ROUT 26 103 35

COUT 103 5 30.000000E-12

XCOM 4 0 103 3 COM SWITCH

DOP 19 25 MDTH 400E-12

VOP 4 25 2.361965E+00

DON 24 19 MDTH 400E-12

VON 24 5 2.361965E+00

\*\*\*\*\* STAND BY \*\*\*\*\*

RMI1 4 111 1E+7

RMI2 0 111 2E+7

RONOFF 6 60 1K

CONOGG 60 0 10p

RSTBIN 60 0 1E+12

ESTBIN 106 0 6 0 1

ESTBREF 106 107 111 0 1

DSTB1 107 108 MDTH 400E-12

VSTB 108 109 0

ISTB 109 0 1U

RSTB 109 110 1

DSTB2 0 110 MDTH 400E-12

XINV 4 0 6 COM INV

.ENDS

**ELECTRICAL CHARACTERISTICS**

V<sub>CC</sub> = ±5V, T<sub>amb</sub> = 25°C (unless otherwise specified)

Symbol	Conditions	Value	Unit
V <sub>io</sub>		0	mV
A <sub>vd</sub>	R <sub>L</sub> = 600Ω	3.2	V/mV
I <sub>CC</sub>	No load / Ampli	5.2	mA
V <sub>icm</sub>		-3 to 4	V
V <sub>OH</sub>	R <sub>L</sub> = 600Ω	+3.6	V
V <sub>OL</sub>	R <sub>L</sub> = 600Ω	-3.6	V
I <sub>sink</sub>	V <sub>o</sub> = 0V	40	mA
I <sub>source</sub>	V <sub>o</sub> = 0V	40	mA
GBP	R <sub>L</sub> = 600Ω, C <sub>L</sub> = 15pF	147	MHz
SR	R <sub>L</sub> = 600Ω, C <sub>L</sub> = 15pF	110	V/μs
φ <sub>m</sub>	R <sub>L</sub> = 600Ω, C <sub>L</sub> = 15pF	42	Degrees



**PACKAGE MECHANICAL DATA**  
16 PINS - PLASTIC MICROPACKAGE (SO)

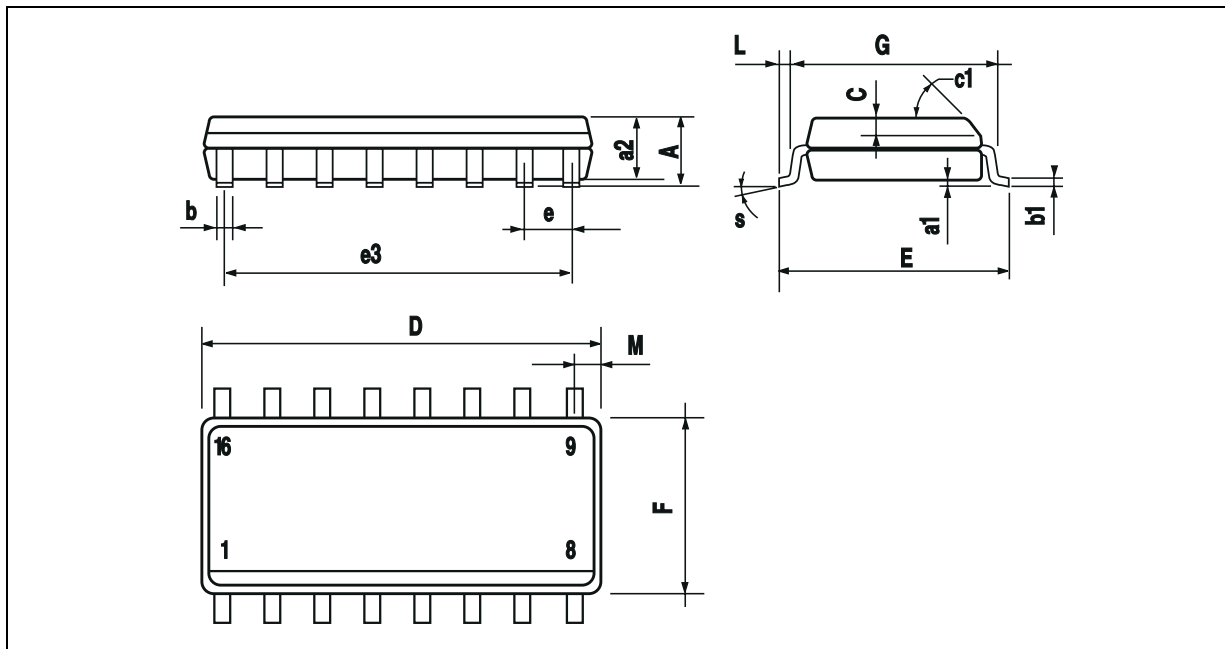

Dim.	Millimeters			Inches		
	Min.	Typ.	Max.	Min.	Typ.	Max.
A			1.75			0.069
a1	0.1		0.2	0.004		0.008
a2			1.6			0.063
b	0.35		0.46	0.014		0.018
b1	0.19		0.25	0.007		0.010
C		0.5			0.020	
c1	45° (typ.)					
D	9.8		10	0.386		0.394
E	5.8		6.2	0.228		0.244
e		1.27			0.050	
e3		8.89			0.350	
F	3.8		4.0	0.150		0.157
G	4.6		5.3	0.181		0.209
L	0.5		1.27	0.020		0.050
M			0.62			0.024
S	8° (max.)					

Information furnished is believed to be accurate and reliable. However, STMicroelectronics assumes no responsibility for the consequences of use of such information nor for any infringement of patents or other rights of third parties which may result from its use. No license is granted by implication or otherwise under any patent or patent rights of STMicroelectronics. Specifications mentioned in this publication are subject to change without notice. This publication supersedes and replaces all information previously supplied. STMicroelectronics products are not authorized for use as critical components in life support devices or systems without express written approval of STMicroelectronics.

© The ST logo is a registered trademark of STMicroelectronics

© 2000 STMicroelectronics - Printed in Italy - All Rights Reserved  
STMicroelectronics GROUP OF COMPANIES

Australia - Brazil - China - Finland - France - Germany - Hong Kong - India - Italy - Japan - Malaysia - Malta - Morocco  
Singapore - Spain - Sweden - Switzerland - United Kingdom

© <http://www.st.com>

